



HIGH EFFICIENCY LED CONTROLLER

Main Features: high efficiency, output current adjustable, high stability, small size, output short circuit protection, and low cost.

Specifications

Part number:	LED22V1A2DW
Input voltage:	7V to 22V
Output voltage:	2V to power supply voltage – 1V
Maximum output current:	1A
Efficiency:	90% typical
Dimming control voltage:	1.25 to 2.5V
Packaging:	FR-4 PCB + epoxy
Operating temperature:	-10°C to 85°C
Dimension:	16mm × 16.7mm × 6mm

Output Pin Description

- Pin 1, SYNC** Digital input. It can be used to synchronize the LED controller switching frequency by an external clock signal.
- Pin 2, SDNG** Digital input. It can be used to shut down the LED controller, has a negative logic: 0 = shut down and 1 = turn on, and is internally pulled up. Leaving this pin unconnected enables the LED controller.
- Pin 3, VSW** Digital output. It can be used to synchronize other LED controllers as the clock signal source. When used as the clock master unit, a higher switching frequency unit must be ordered and the part number becomes: LED22V1A2DWM.
- Pin 4, 2.5V** Analog output. The reference voltage of 2.5V used by the controller. It has a 20ppm/°C drift and can provide ± 1mA current.
- Pin 5, LIS** Analog input/output. It can be used to set the output LED current or indicate the voltage for setting the output LED current. The relationship between this voltage and the output current is: LED current = (LIS (V) – 1.25V)/1.25 (A). For example, when this voltage equals to 2V, the output LED current is (2 – 1.25)/1.25 = 0.6A. The internal circuit is shown in Figure 1.
- Pin 6, GND** Power input. Connect it to the power supply return terminal.
- Pin 7, VPS** Power input. Connect it to the power supply positive terminal.
- Pin 8, LEDA** Analog output. Connect it to the LED's positive terminal, the anode.
- Pin 9, LECD** Analog output. Connect it to the LED's negative terminal, the cathode.

Applications

The LED22V1A2DW is a compact high efficiency LED controller. No heat sink is needed for operation. The output current can be set either by an internal POT (Potentiometer) on the top side of the controller, by an external POT, or an external DAC (Digital to Analog Converter). The voltage required for setting the output LED current from 0 to 1A is 1.25V to 2.5V. I.e., when setting LIS (pin 5) to 1.25V or below, the correspondent output LED current is 0; when setting to 2.5V (the reference voltage provided by the controller), the output current is 1A.



When using multiple LED22V1A2DW units within one system, it would be better to have all their switching frequencies synchronized, thus minimizing the ripple voltage across the power supply and interferences to other electronics. Two ways to synchronize their switching frequencies:

1. Use an external clock signal of between 750KHz to 1MHz and connect it to the SYNC pins (#1) of all the controllers.
2. Use one of the LED controllers as a master unit (ordering part number: LED22V1A2DWM) and the rest as slave units. Connect the VSW pin (#3) of the master unit to the SYNC pins (#1) of all the slave units.

Figure 1 shows the connection for typical applications. Please note that all the optional connections are not necessary for the controller to operate. The circuitries shown inside the controller boarder are the internal circuits embedded in the controller. Figure 2 shows the top view of the controllers and its connection wires, the POT, and the soldering pads for the optional connections.

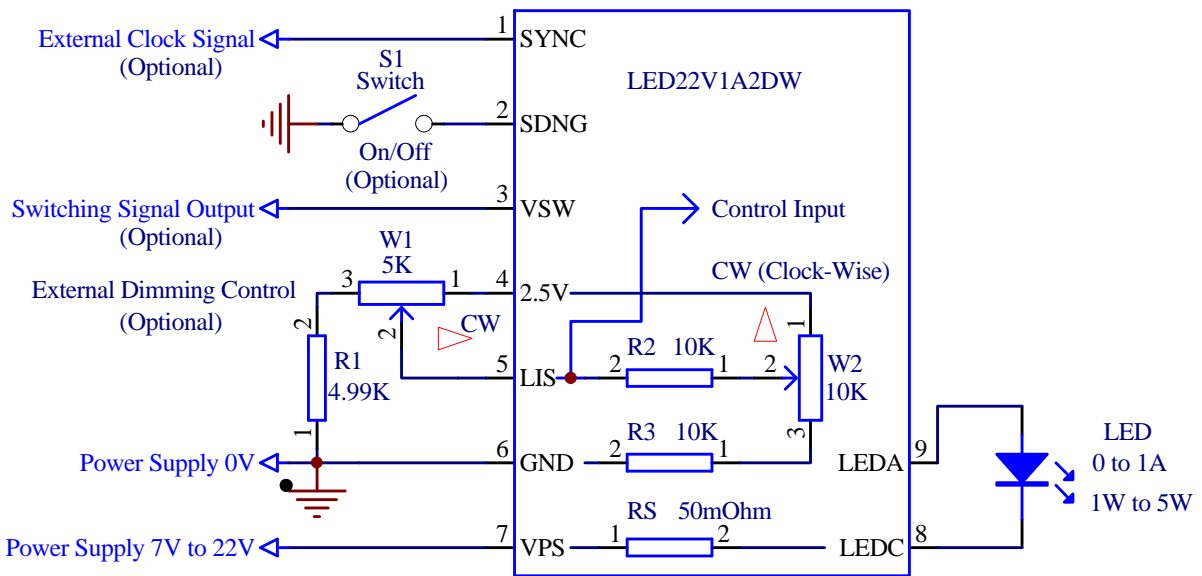

Figure 1 Typical Application of LED Controller LED22V1A2DW

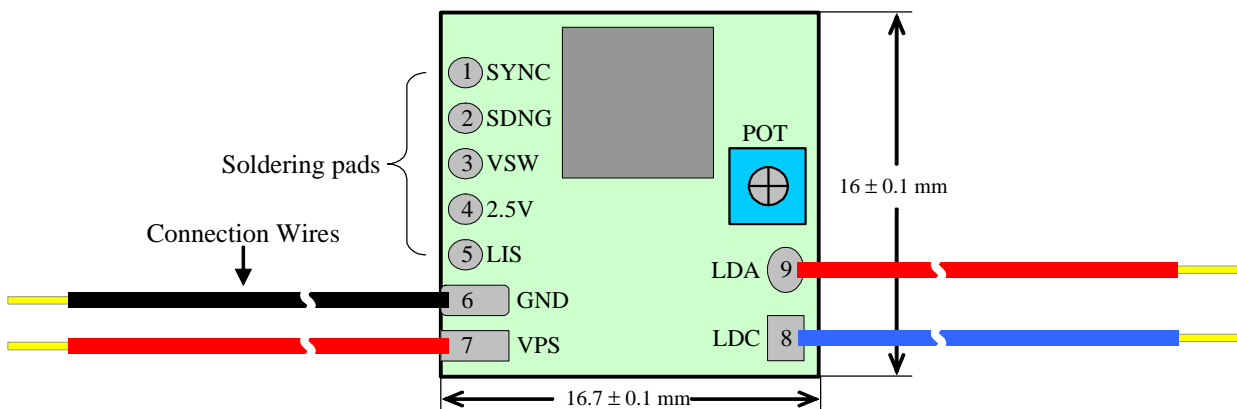

Figure 2 Top View

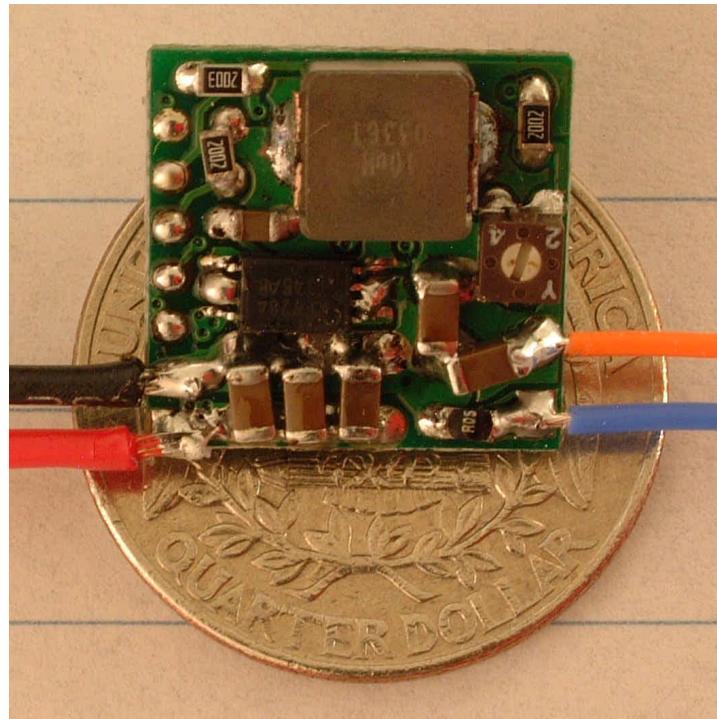

Figure 3 LED22V1A2DW Picture



Part Numbers for Ordering

Part Number	Note
LED22V1A2DW	It can be used as the <u>slave</u> unit for multiple unit operation.
LED22V1A2DWM	It can be used as the <u>master</u> unit for multiple unit operation.

Prices and Lead-Times for Ordering

Part Number	1 – 9 PCs	10 – 49 PCs	50 – 249 PCs	250 – 999 PCs	1000 PCs and up
LED22V1A2DW	\$28	\$24	\$18	\$14	\$12
LED22V1A2DWM	\$28	\$24	\$18	\$14	\$12
Lead Time	1 week	2 weeks	2 weeks	3 weeks	Contact us

Note: ATI retains the ownership of full rights for its LED controller technologies, associated the designs for mechanics and electronics, plus all modifications, improvements, and inventions made by ATI.