

ICPL2631
ICPL2630



DUAL CHANNEL, HIGH CMR, VERY HIGH SPEED OPTICALLY COUPLED ISOLATOR LOGIC GATE OUTPUT

APPROVALS

- UL recognised, File No. E91231

DESCRIPTION

The ICPL2630 / ICPL2631 are dual channel optocouplers consisting of GaAsP light emitting diodes and high gain integrated photo detectors to provide 3500Volts_{RMS} electrical isolation between input and output. The output of the detector I.C.'s are open collector Schottky clamped transistors. The ICPL2631 has an internal shield which provides a guaranteed common mode transient immunity specification of 1000V/μs minimum. This unique design provides maximum ac and dc circuit isolation while achieving TTL compatibility. The coupled parameters are guaranteed over the temperature range of 0°C to 70°C, such that a maximum input signal of 5mA will provide a minimum output sink current of 13mA (equivalent to fan-out of eight gates)

FEATURES

- High speed - 10MBit/s
- High Common Mode Transient Immunity 10kV/μs typical
- Logic gate output
- ICPL2631 has improved noise shield for superior common mode rejection
- Options :-
10mm lead spread - add G after part no.
Surface mount - add SM after part no.
Tape&reel - add SMT&R after part no.

APPLICATIONS

- Line receiver, data transmission
- Computer-peripheral interface
- Data multiplexing
- Pulse transformer replacement

OPTION SM SURFACE MOUNT

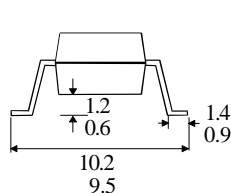

OPTION G

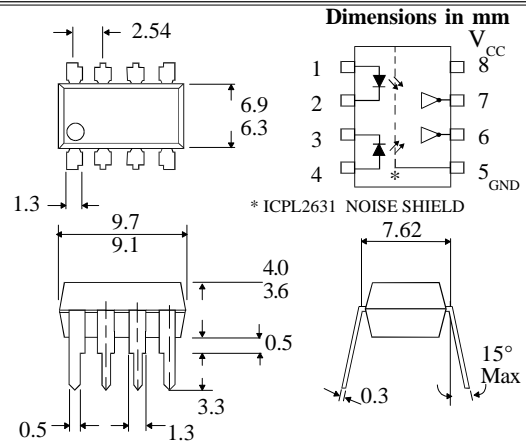
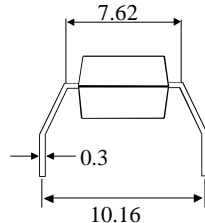

ABSOLUTE MAXIMUM RATINGS (25°C unless otherwise specified)

Storage Temperature _____ -55°C to + 125°C
Operating Temperature _____ 0°C to + 70°C
Lead Soldering Temperature
(1/16 inch (1.6mm) from case for 10 secs) 260°C

INPUT DIODE

Average Forward Current _____ 15mA (note 5)
Peak Forward Current _____ 30mA (less than 1msec duration)(note 5)
Reverse Voltage _____ 5V (note 5)

DETECTOR

Supply Voltage(V_{cc}) _____ 7V (1 minute maximum)
Output Current (I_O) _____ 16mA (note 5)
Output Voltage (V_O) _____ 7V (note 5)
Collector Output Power Dissipation _____ 60mW

ISOCOM COMPONENTS LTD

Unit 25B, Park View Road West,
Park View Industrial Estate, Brenda Road
Hartlepool, Cleveland, TS25 1YD
Tel: (01429) 863609 Fax :(01429) 863581

ISOCOM INC

1024 S. Greenville Ave, Suite 240,
Allen, TX 75002 USA
Tel: (214) 495-0755 Fax: (214) 495-0901
e-mail info@isocom.com
http://www.isocom.com

ELECTRICAL CHARACTERISTICS (T_A = 0°C to 70°C Unless otherwise noted)

PARAMETER	SYM	DEVICE	MIN	TYP*	MAX	UNITS	TEST CONDITION
High Level Output Current (note 5)	I _{OH}			2	250	μA	V _{CC} = 5.5V, V _O = 5.5V I _F = 250μA
Low Level Output Voltage (note 5)	V _{OL}			0.4	0.6	V	V _{CC} = 5.5V, I _F = 5mA I _{OL} (sinking) = 13mA
High Level Supply Current (both channels)	I _{CCH}			14	30	mA	V _{CC} = 5.5V, I _F = 0mA
Low Level Supply Current (both channels)	I _{CCL}			26	36	mA	V _{CC} = 5.5V, I _F = 10mA
Input Forward Voltage	V _F			1.55	1.75	V	I _F = 10mA, T _A = 25°C
Input Reverse Breakdown Voltage	V _{BR}		5			V	I _R = 10μA, T _A = 25°C
Input Capacitance	C _{IN}			60		pF	V _F = 0, f = 1MHz
Temperature Coefficient of Forward Voltage	$\frac{\Delta V_F}{\Delta T_A}$			-1.4		mV/°C	I _F = 10mA
Input-output Isolation Voltage (note 4)	V _{ISO}		2500	5000		V _{RMS}	R.H.equal to or less than 50%, t = 1min. T _A = 25°C
Input-output Insulation Leakage Current (note 4)	I _{I-O}				1	μA	R.H = 45% t = 5s, T _A = 25°C V _{I-O} = 3000V dc
Resistance (Input to Output) (note 4)	R _{I-O}			10 ¹²		Ω	V _{I-O} = 500V dc
Capacitance (Input to Output) (note 4)	C _{I-O}			0.6		pF	f = 1MHz
Input-input Insulation Leakage Current (note 6)	I _{I-I}			0.005		μA	R.H = 45% t = 5s, T _A = 25°C V _{I-O} = 500V dc
Resistance (Input to input) (note 6)	R _{I-I}			10 ¹¹		Ω	V _{I-O} = 500V dc
Capacitance (Input to input) (note 6)	C _{I-I}			0.6		pF	f = 1MHz

* All typicals at T_A = 25°C

RECOMMENDED OPERATING CONDITIONS

PARAMETER	SYMBOL	MIN	MAX	UNITS
Input Current, Low Level	I _{FL}	0	250	μA
Input Current, High Level	I _{FH}	6.3*	15	mA
Supply Voltage, Output	V _{CC}	4.5	5.5	V
Fan Out (TTL Load)	N		8	
Operating Temperature	T _A	0	70	°C

*6.3mA is a guard banded value which allows for at least 20% CTR degradation.
Initial input current threshold value is 5.0mA or less

SWITCHING SPECIFICATIONS AT $T_A = 25^\circ\text{C}$ ($V_{CC} = 5\text{V}$, $I_F = 7.5\text{mA}$ Unless otherwise noted)

PARAMETER	SYM	DEVICE	MIN	TYP	MAX	UNITS	TEST CONDITION
Propagation Delay Time to Logic Low at Output (fig 1)(note2)	t_{PHL}			55	75	ns	$R_L = 350\Omega$, $C_L = 15\text{pF}$
Propagation Delay Time to Logic High at Output (fig 1)(note3)	t_{PLH}			45	75	ns	$R_L = 350\Omega$, $C_L = 15\text{pF}$
Common Mode Transient Immunity at Logic High Level Output (fig 2)(note7)	CM_H	ICPL2630 ICPL2631	1000	10000	10000	V/ μs V/ μs	$I_F = 0\text{mA}$, $V_{CM} = 50V_{PP}$ $R_L = 350\Omega$, $V_{OH} = 2V_{min.}$
Common Mode Transient Immunity at Logic Low Level Output (fig 2)(note8)	CM_L	ICPL2630 ICPL2631	-1000	-10000	-10000	V/ μs V/ μs	$V_{CM} = 50V_{PP}$ $R_L = 350\Omega$, $V_{OL} = 0.8V_{max.}$

NOTES:-

- 1 Bypassing of the power supply line is required, with a $0.01\mu\text{F}$ ceramic disc capacitor adjacent to each isolator. The power supply bus for the isolator(s) should be separate from the bus for any active loads. Otherwise a larger value of bypass capacitor (up to $0.1\mu\text{F}$) may be needed to suppress regenerative feedback via the power supply.
- 2 The t_{PHL} propagation delay is measured from the 3.75mA level Low to High transition of the input current pulse to the 1.5V level on the High to Low transition of the output voltage pulse.
- 3 The t_{PLH} propagation delay is measured from the 3.75mA level High to Low transition of the input current pulse to the 1.5V level on the Low to High transition of the output voltage pulse.
- 4 Device considered a two terminal device; pins 1, 2, 3, and 4 shorted together, and pins 5, 6, 7 and 8 shorted together.
- 5 Each channel.
- 6 Measured between pins 1 and 2 shorted together and pins 3 and 4 shorted together.
- 7 CM_H is the maximum tolerable rate of rise of the common mode voltage to assure that the output will remain in a high logic state (ie $V_{out} > 2.0\text{V}$).
- 8 CM_L is the maximum tolerable rate of fall of the common mode voltage to assure that the output will remain in a low logic state (ie $V_{out} < 0.8\text{V}$)

FIG.1 SWITCHING TEST CIRCUIT

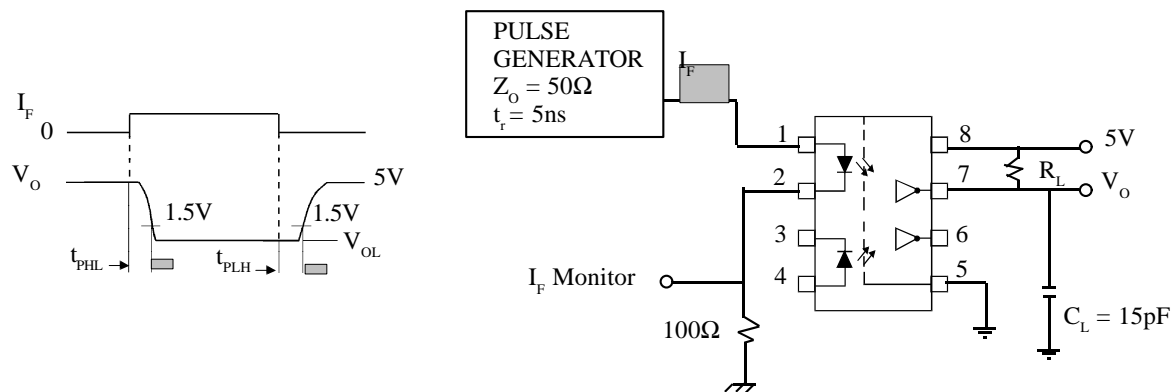

FIG. 2 TEST CIRCUIT FOR TRANSIENT IMMUNITY AND TYPICAL WAVEFORMS

