

- Capacitive Micromachined
- Nitrogen Damped
- ±4V Differential Output or 0.5V to 4.5V Single Ended Output
- Fully Calibrated
- Low Power Consumption
- -55 to +125°C Operation
- +5V DC Power
- Simple, Four Wire Connection
- Serialized for Traceability
- Responds to DC & AC Acceleration
- Non Standard Ranges Available
- Rugged Black Anodized Aluminum Module

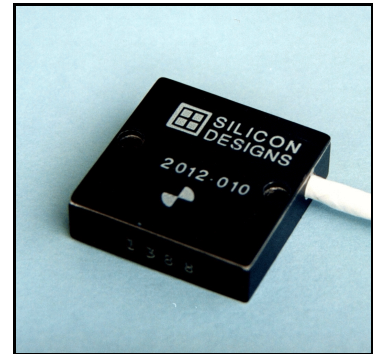

ACTUAL SIZE

DESCRIPTION

The Model 2012 accelerometer module provides a rugged protective case around an integrated model 1210L accelerometer for measuring accelerations in commercial/industrial environments. It is tailored for zero to medium frequency instrumentation applications. The anodized aluminum case is epoxy sealed and is easily mounted via two #4 (or M3) screws. It is relatively insensitive to temperature changes and gradients. The cable's shield is electrically connected to the case while the ground (GND) wire is isolated from the case. An optional initial calibration sheet (2012-CAL) and periodic calibration checking are also available. Please refer to the Model 2210 for applications that require a lower output impedance or greater power supply rejection ratio than the Model 2012 provides.

ORDERING INFORMATION

Full Scale Acceleration	Model Number
± 2 g	2012-002
± 5 g	2012-005
± 10 g	2012-010
± 25 g	2012-025
± 50 g	2012-050
±100 g	2012-100
±200 g	2012-200
±400 g	2012-400

OPERATION

The Model 2012 accelerometer module produces two analog voltage outputs, **AOP** & **AON**, which vary with acceleration as shown in the graph at right. The signal outputs are fully differential about a common mode voltage of 1/2 V_{DD} (approximately 2.5 volts). At zero acceleration, the output differential voltage is nominally zero volts; at +full scale acceleration, the output differential voltage is +4 volts; at -full scale acceleration the output differential voltage is -4 volts. The sensitive axis is perpendicular to the bottom of the package, with positive acceleration defined as a force pushing on the bottom of the package.

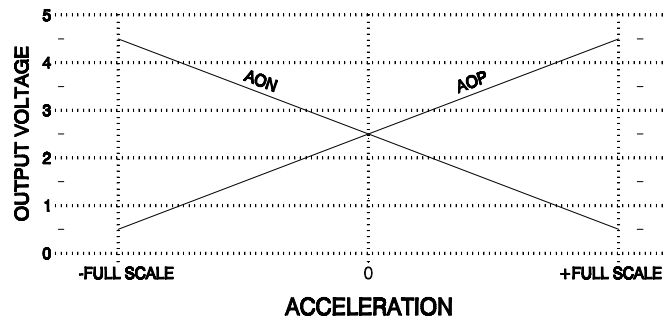

SIGNAL DESCRIPTIONS

V_{DD} and GND (Power): Red and Black wires respectively. Power (+5 Volts DC) and ground.

AOP and AON (Output): Green & white wires respectively. AOP voltage increases (AON decreases) with positive acceleration. At zero acceleration, both outputs are nominally equal to 2.5 volts. The device experiences positive (+1g) acceleration with its lid facing up in the Earth's gravitational field. Either output can be used individually or the pair can be used differentially.

APPLICATIONS

- VIBRATION MONITORING
- VIBRATION ANALYSIS
- MACHINE CONTROL
- MODAL ANALYSIS
- ROBOTICS
- CRASH TESTING
- INSTRUMENTATION
- ROTATING MACHINERY

SPECIFICATIONS SUBJECT TO CHANGE WITHOUT NOTICE

Model 2012 Analog Accelerometer Module

ABSOLUTE MAXIMUM RATINGS *

Case Operating Temperature -55 to +125°C
 Storage Temperature -55 to +125°C
 Acceleration Over-range 2000g for 0.1 ms
 Voltage on V_{DD} to GND -0.5V to 6.5V
 Voltage on AOP or AON to GND¹ -0.5V to V_{DD}+0.5V
 Power Dissipation 250 mW

* **NOTICE:** Stresses above those listed under "Absolute Maximum Ratings" may cause permanent damage to the device. These are stress ratings only. Functional operation of the device at or above these conditions is not implied. Exposure to absolute maximum rating conditions for extended periods may affect device reliability.

ESD CONSIDERATIONS:

The model 2012 accelerometer is a CMOS device subject to damage by large electrostatic discharges. Diode protection is provided on the outputs but care should be exercised during handling of the cable wire ends. Individuals and tools should be grounded before coming in contact with the cable wire ends.

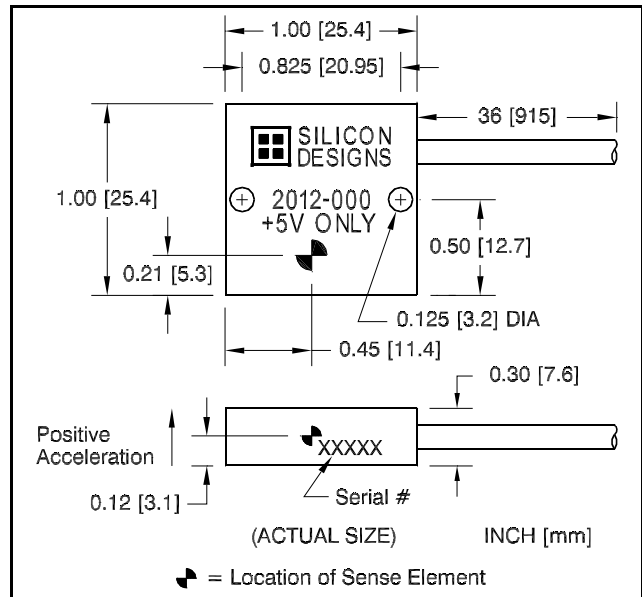

PERFORMANCE - By Model: V _{DD} =+5VDC, T _C =25°C.									
MODEL NUMBER	2012-002	2012-005	2012-010	2012-025	2012-050	2012-100	2012-200	2012-400	Units
Input Range	±5	±10	±10	±25	±50	±100	±200	±200	g
Frequency Response (Nominal, 3 dB)	0 - 300	0 - 400	0 - 600	0 - 1000	0 - 1600	0 - 2000	0 - 2500	0 - 3000	Hz
Sensitivity - Differential ²	2000	800	400	160	80	40	20	10	mV/g
Output Noise (differential RMS, typical)	13	32	63	158	316	632	1265	2530	µg/(root Hz)
Max. Mechanical Shock (0.1 ms)	2000								g

PERFORMANCE - All Models: Unless otherwise specified, V _{DD} =+5VDC, T _C =25°C, Differential Mode.				
PARAMETER	Min	Typ	Max	Units
Cross Axis Sensitivity		2	3	%
Bias Calibration Error ³	-002	2	4	% of span
	-005	1	3	
	-010 thru -400	1	2	
Bias Temperature Shift (T _C = -55 to +125°C) ³	-002 & -005	100	300	(ppm of span)/°C
	-010 thru -400	50	200	
Scale Factor Calibration Error ^{3,4}		1	2	%
Scale Factor Temperature Shift (T _C = -55 to +125°C) ³		+300		ppm/°C
Non-Linearity (-90 to +90% of Full Scale) ^{3,4}	-002 thru -100	0.5	1.0	% of span
	-200	0.7	1.5	
	-400	1.0	2.0	
Power Supply Rejection Ratio		25		dB
Output Impedance		90		Ω
Operating Voltage	4.75	5.0	5.25	V
Operating Current ³		8	10	mA
Mass (not including cable)		8		grams
Cable Mass		25		grams/meter

Notes:

1. Voltages on the AOP & AON signal wires may exceed 0.5 volt above or below the supply voltages provided the current is limited to 1 mA.
2. Single ended sensitivity is half of values shown.
3. Tighter tolerances available on special order.
4. 100g versions and above are tested from -65g to +65g.

SPECIFICATIONS SUBJECT TO CHANGE WITHOUT NOTICE

Silicon Designs, Inc. • 1445-NW Mall Street, Issaquah, WA 98027-5344 • Phone: 425-391-8329 • Fax: 425-391-0446

web site: www.silicondesigns.com

[page 2]

Sep 07

CABLE SPECIFICATIONS & LENGTH CONSIDERATIONS

The cable consists of four 26 AWG (7x34) silver plated copper wires with PTFE insulation surrounded by a braided shield. The shield jacket is a PTFE tape wrap with a nominal outer diameter of 0.131". Extending the model 2012's one meter cable is not recommended. If you do decide to connect additional cable, we recommend you check each individual installation for oscillation by tapping the accelerometer and watching the differential output for oscillation in the 20kHz to 50kHz region. If no oscillation is present, then the additional cable length being used is OK for that particular device.

CONVERTING THE 2012's DIFFERENTIAL OUTPUT TO SINGLE ENDED

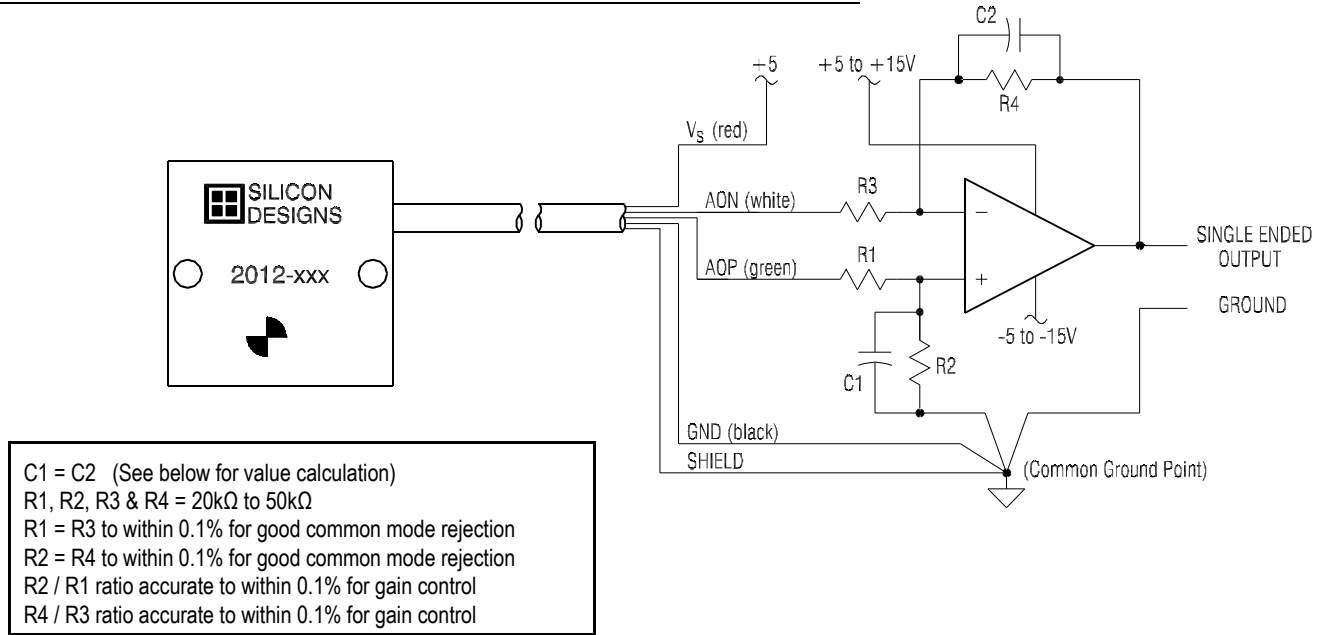

To achieve the highest resolution and lowest noise performance from your model 2012 accelerometer module, it should be connected to your voltage measurement instrument in a differential configuration using both the **AOP** and **AON** output signals. If your measurement instrument lacks differential input capability or you desire to use a differential input capable instrument in single ended mode, then the circuit above can be used to preserve the low noise performance of the model 2012 while using a single ended type connection.

This circuit converts the ± 4 Volt differential output of the model 2012 accelerometer, centered at +2.5 Volts, to a single ended output centered about ground (0.0 Volts). It provides the advantage of low common mode noise by preventing the accelerometer's ground current from causing an error in the voltage reading.

The op-amp should be located as close as possible to your voltage monitoring equipment so that the majority of the signal path is differential. Any noise present along the differential path will affect both wires to the same degree and the op-amp will reject this noise because it is a common mode signal. The op-amp type is not critical; a $\mu A741$ or $1/4$ of a LM124 can be used. Both plus and minus supplies are needed for the op-amp to accommodate the positive and negative swings of the single ended output. The same +5V supply can be used for both the op-amp and the 2012 or a higher voltage positive supply can be used for the op-amp if you need a larger single ended output swing.

For this design, always set $R_1 = R_3$, $R_2 = R_4$ and $C_1 = C_2$. The gain of the circuit is then determined by the ratio R_2/R_1 . When $R_1 = R_2 = R_3 = R_4$, the gain equals 1 and the output swing will be ± 4 Volts single ended with respect to ground. To obtain a ± 5 Volt single ended output, set $R_2/R_1 = R_4/R_3 = 5/4 = 1.25$. The single ended output of the op-amp will be centered at ground if R_2 and C_1 are tied to ground; using some other fixed voltage for this reference will shift the output. The value of the optional capacitors C_1 and C_2 ($C_1 = C_2$) can be selected to roll off the frequency response to the frequency range of interest. The cutoff frequency f_0 (-3 dB frequency) for this single order low pass filter is given by:

$$f_0 = \frac{1}{2\pi R_2 C_1}$$