

## Stereo CODEC With Speaker Driver

### DESCRIPTION

The WM8978 is a low power, high quality stereo CODEC designed for portable applications such as multimedia phone, digital still camera or digital camcorder.

The device integrates preamps for stereo differential mics, and includes drivers for speakers, headphone and differential or stereo line output. External component requirements are reduced as no separate microphone or headphone amplifiers are required.

Advanced on-chip digital signal processing includes a 5-band equaliser, a mixed signal Automatic Level Control for the microphone or line input through the ADC as well as a purely digital limiter function for record or playback. Additional digital filtering options are available in the ADC path, to cater for application filtering such as 'wind noise reduction'.

The WM8978 digital audio interface can operate as a master or a slave. An internal PLL can generate all required audio clocks for the CODEC from common reference clock frequencies, such as 12MHz and 13MHz.

The WM8978 operates at analogue supply voltages from 2.5V to 3.3V, although the digital core can operate at voltages down to 1.71V to save power. The speaker outputs and OUT3/4 line outputs can run from a 5V supply if increased output power is required. Individual sections of the chip can also be powered down under software control.

### FEATURES

#### Stereo CODEC:

- DAC SNR 98dB, THD -84dB ('A' weighted @ 48kHz)
- ADC SNR 95dB, THD -84dB ('A' weighted @ 48kHz)
- On-chip Headphone Driver with 'capless' option
  - 40mW per channel into 16Ω / 3.3V SPKVDD
- 0.9W output power into 8Ω BTL speaker / 5V SPKVDD
  - Capable of driving piezo speakers
  - Stereo speaker drive configuration

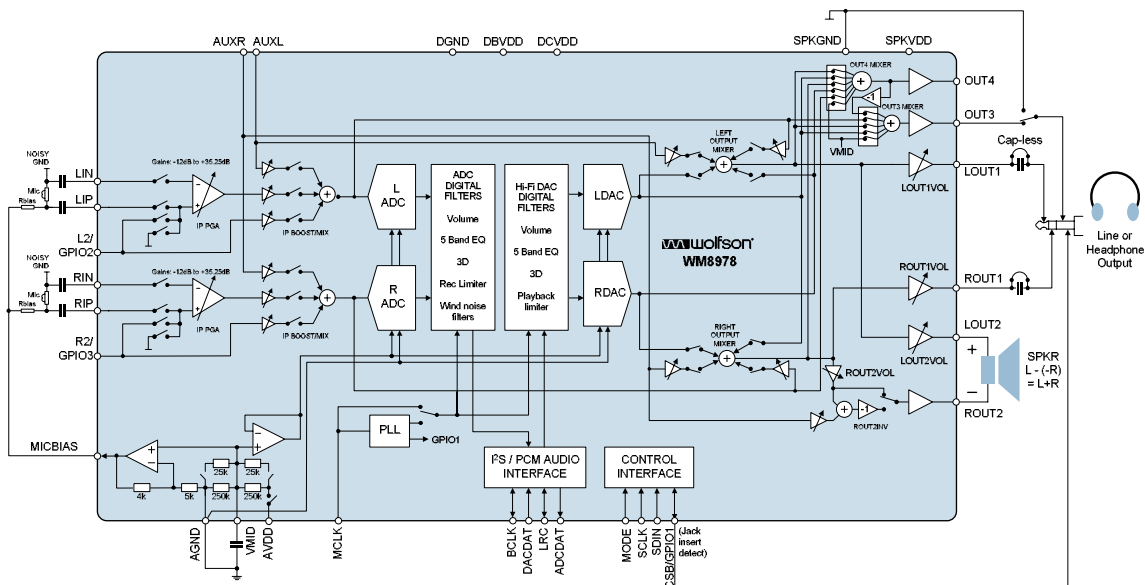
#### Mic Preamps:

- Stereo Differential or mono microphone Interfaces
  - Programmable preamp gain
  - Pseudo differential inputs with common mode rejection
  - Programmable ALC / Noise Gate in ADC path
- Low-noise bias supplied for electret microphones

#### Other Features:

- Enhanced 3-D function for improved stereo separation
- Digital playback limiter
- 5-band Equaliser (record or playback)
- Programmable ADC High Pass Filter (wind noise reduction)
- Programmable ADC Notch Filter
- Aux inputs for stereo analog input signals or 'beep'
- On-chip PLL supporting 12, 13, 19.2MHz and other clocks
- Support for 8, 11.025, 12, 16, 22.05, 24, 32, 44.1 and 48kHz sample rates
- Low power, low voltage
  - 2.5V to 3.6V (digital: 1.71V to 3.6V)
- 5x5mm 32-lead QFN package

### BLOCK DIAGRAM



### APPLICATIONS

- Stereo Camcorder or DSC
- Multimedia Phone

---

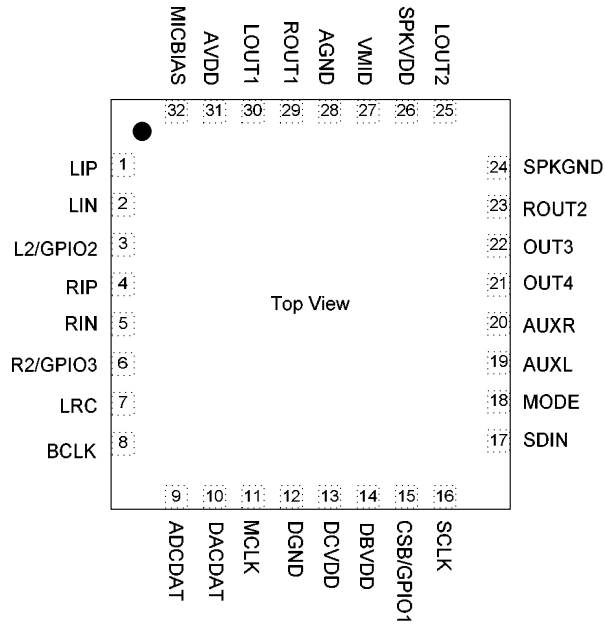
**TABLE OF CONTENTS**

<b>DESCRIPTION</b> .....	<b>1</b>
<b>BLOCK DIAGRAM</b> .....	<b>1</b>
<b>FEATURES</b> .....	<b>1</b>
<b>APPLICATIONS</b> .....	<b>1</b>
<b>TABLE OF CONTENTS</b> .....	<b>2</b>
<b>PIN CONFIGURATION</b> .....	<b>4</b>
<b>ORDERING INFORMATION</b> .....	<b>4</b>
<b>PIN DESCRIPTION</b> .....	<b>5</b>
<b>ABSOLUTE MAXIMUM RATINGS</b> .....	<b>6</b>
<b>RECOMMENDED OPERATING CONDITIONS</b> .....	<b>6</b>
<b>ELECTRICAL CHARACTERISTICS</b> .....	<b>7</b>
TERMINOLOGY .....	10
<b>SPEAKER OUTPUT THD VERSUS POWER</b> .....	<b>11</b>
<b>POWER CONSUMPTION</b> .....	<b>12</b>
<b>AUDIO PATHS OVERVIEW</b> .....	<b>14</b>
<b>SIGNAL TIMING REQUIREMENTS</b> .....	<b>15</b>
SYSTEM CLOCK TIMING .....	15
AUDIO INTERFACE TIMING – MASTER MODE .....	15
AUDIO INTERFACE TIMING – SLAVE MODE.....	16
CONTROL INTERFACE TIMING – 3-WIRE MODE .....	17
CONTROL INTERFACE TIMING – 2-WIRE MODE .....	18
<b>INTERNAL POWER ON RESET CIRCUIT</b> .....	<b>19</b>
RECOMMENDED POWER UP/DOWN SEQUENCE .....	21
<b>DEVICE DESCRIPTION</b> .....	<b>25</b>
INTRODUCTION .....	25
INPUT SIGNAL PATH .....	27
ANALOGUE TO DIGITAL CONVERTER (ADC).....	34
INPUT LIMITER / AUTOMATIC LEVEL CONTROL (ALC) .....	40
OUTPUT SIGNAL PATH .....	52
3D STEREO ENHANCEMENT .....	59
ANALOGUE OUTPUTS.....	59
DIGITAL AUDIO INTERFACES.....	75
AUDIO SAMPLE RATES .....	80
MASTER CLOCK AND PHASE LOCKED LOOP (PLL).....	80
COMPANDING .....	83
GENERAL PURPOSE INPUT/OUTPUT .....	85
OUTPUT SWITCHING (JACK DETECT).....	86
CONTROL INTERFACE.....	88
RESETTING THE CHIP .....	89
POWER SUPPLIES .....	89
POWER MANAGEMENT .....	90
<b>REGISTER MAP</b> .....	<b>91</b>
REGISTER BITS BY ADDRESS .....	93
<b>DIGITAL FILTER CHARACTERISTICS</b> .....	<b>110</b>
TERMINOLOGY .....	110
DAC FILTER RESPONSES.....	111
ADC FILTER RESPONSES.....	111
HIGHPASS FILTER.....	112
5-BAND EQUALISER.....	113

---

<b>APPLICATION INFORMATION</b> .....	<b>117</b>
RECOMMENDED EXTERNAL COMPONENTS .....	117
<b>PACKAGE DIAGRAM</b> .....	<b>118</b>
<b>IMPORTANT NOTICE</b> .....	<b>119</b>
ADDRESS: .....	119

**PIN CONFIGURATION**



**ORDERING INFORMATION**

ORDER CODE	TEMPERATURE RANGE	PACKAGE	MOISTURE SENSITIVITY LEVEL	PEAK SOLDERING TEMPERATURE
WM8978GEFL/V	-25°C to +85°C	32-lead QFN (5 x 5 mm) (Pb-free)	MSL3	260°C
WM8978GEFL/RV	-25°C to +85°C	32-lead QFN (5 x 5 mm) (Pb-free, tape and reel)	MSL3	260°C

**Note:**

Reel quantity = 3,500

**PIN DESCRIPTION**

PIN	NAME	TYPE	DESCRIPTION
1	LIP	Analogue input	Left Mic Pre-amp positive input
2	LIN	Analogue input	Left Mic Pre-amp negative input
3	L2/GPIO2	Analogue input	Left channel line input/secondary mic pre-amp positive input/GPIO2 pin
4	RIP	Analogue input	Right Mic Pre-amp positive input
5	RIN	Analogue input	Right Mic Pre-amp negative input
6	R2/GPIO3	Analogue input	Right channel line input/secondary mic pre-amp positive input/GPIO3 pin
7	LRC	Digital Input / Output	DAC and ADC Sample Rate Clock
8	BCLK	Digital Input / Output	Digital Audio Port Clock
9	ADCDAT	Digital Output	ADC Digital Audio Data Output
10	DACDAT	Digital Input	DAC Digital Audio Data Input
11	MCLK	Digital Input	Master Clock Input
12	DGND	Supply	Digital ground
13	DCVDD	Supply	Digital core logic supply
14	DBVDD	Supply	Digital buffer (I/O) supply
15	CSB/GPIO1	Digital Input / Output	3-Wire Control Interface Chip Select / GPIO1 pin
16	SCLK	Digital Input	3-Wire Control Interface Clock Input / 2-Wire Control Interface Clock Input
17	SDIN	Digital Input / Output	3-Wire Control Interface Data Input / 2-Wire Control Interface Data Input
18	MODE	Digital Input	Control Interface Selection
19	AUXL	Analogue input	Left Auxillary input
20	AUXR	Analogue input	Right Auxillary input
21	OUT4	Analogue Output	Buffered midrail Headphone pseudo-ground, or Right line output or MONO mix output
22	OUT3	Analogue Output	Buffered midrail Headphone pseudo-ground, or Left line output
23	ROUT2	Analogue Output	Second right output, or BTL speaker driver positive output
24	SPKGND	Supply	Speaker ground (feeds speaker amp and OUT3/OUT4)
25	LOUT2	Analogue Output	Second left output, or BTL speaker driver negative output
26	SPKVDD	Supply	Speaker supply (feed speaker amp only)
27	VMID	Reference	Decoupling for ADC and DAC reference voltage
28	AGND	Supply	Analogue ground (feeds ADC and DAC)
29	ROUT1	Analogue Output	Headphone or Line Output Right
30	LOUT1	Analogue Output	Headphone or Line Output Left
31	AVDD	Supply	Analogue supply (feeds ADC and DAC)
32	MICBIAS	Analogue Output	Microphone Bias

**Note:**

It is recommended that the QFN ground paddle should be connected to analogue ground on the application PCB. Refer to the application note WAN\_0118 on "Guidelines on How to Use QFN Packages and Create Associated PCB Footprints".

## ABSOLUTE MAXIMUM RATINGS

Absolute Maximum Ratings are stress ratings only. Permanent damage to the device may be caused by continuously operating at or beyond these limits. Device functional operating limits and guaranteed performance specifications are given under Electrical Characteristics at the test conditions specified.



ESD Sensitive Device. This device is manufactured on a CMOS process. It is therefore generically susceptible to damage from excessive static voltages. Proper ESD precautions must be taken during handling and storage of this device.

Wolfson tests its package types according to IPC/JEDEC J-STD-020B for Moisture Sensitivity to determine acceptable storage conditions prior to surface mount assembly. These levels are:

MSL1 = unlimited floor life at <30°C / 85% Relative Humidity. Not normally stored in moisture barrier bag.

MSL2 = out of bag storage for 1 year at <30°C / 60% Relative Humidity. Supplied in moisture barrier bag.

MSL3 = out of bag storage for 168 hours at <30°C / 60% Relative Humidity. Supplied in moisture barrier bag.

The Moisture Sensitivity Level for each package type is specified in Ordering Information.

CONDITION	MIN	MAX
DBVDD, DCVDD, AVDD supply voltages	-0.3V	+4.5V
SPKVDD supply voltage	-0.3V	+7V
Voltage range digital inputs	DGND -0.3V	DVDD +0.3V
Voltage range analogue inputs	AGND -0.3V	AVDD +0.3V
Operating temperature range, T <sub>A</sub>	-25°C	+85°C
Storage temperature after soldering	-65°C	+150°C

### Notes:

1. Analogue and digital grounds must always be within 0.3V of each other.
2. All digital and analogue supplies are completely independent from each other.
3. Analogue supply has to be  $\geq$  to digital.
4. In non-boosted mode, SPKVDD should = AVDD, if boosted SPKVDD should be  $\geq 1.5 \times$  AVDD.
5. When using PLL, DCVDD should be  $\geq 1.9V$ .
6. DBVDD must be greater than or equal to DCVDD.

## RECOMMENDED OPERATING CONDITIONS

PARAMETER	SYMBOL	TEST CONDITIONS	MIN	TYP	MAX	UNIT
Digital supply range (Core)	DCVDD		1.71 <sup>1</sup>		3.6	V
Digital supply range (Buffer)	DBVDD		1.71		3.6	V
Analogue core supply range	AVDD		2.5		3.6	V
Analogue output supply range	SPKVDD		2.5		5.5	V
Ground	DGND, AGND, SPKGND			0		V

### Notes:

1. When using the PLL, DCVDD must not be less than 1.9V.

## ELECTRICAL CHARACTERISTICS

### Test Conditions

DCVDD=1.8V, AVDD=DBVDD=SPKVDD= 3.3V, T<sub>A</sub> = +25°C, 1kHz signal, fs = 48kHz, 24-bit audio data unless otherwise stated.

PARAMETER	SYMBOL	TEST CONDITIONS	MIN	TYP	MAX	UNIT
<b>Microphone Preamp Inputs (LIP, LIN, RIP, RIN, L2, R2)</b>						
Full-scale Input Signal Level – note this changes in proportion to AVDD (Note 1)	V <sub>INFS</sub>	PGABOOST = 0dB INPPGAVOL = 0dB		1.0 0		V <sub>rms</sub> dBV
Mic PGA equivalent input noise	At 35.25dB gain	0 to 20kHz		150		µV
Input resistance	R <sub>MICIN</sub>	Gain set to 35.25dB		1.6		kΩ
	R <sub>MICIN</sub>	Gain set to 0dB		47		kΩ
	R <sub>MICIN</sub>	Gain set to -12dB		75		kΩ
	R <sub>MICIP</sub>	L/RIP2INPPGA = 1		94		kΩ
	C <sub>MICIN</sub>			10		pF
<b>MIC Programmable Gain Amplifier (PGA)</b>						
Programmable Gain			-12		35.25	dB
Programmable Gain Step Size		Guaranteed monotonic		0.75		dB
Mute Attenuation				120		dB
<b>Selectable Input Gain Boost (0/+20dB)</b>						
Gain Boost on PGA input		Boost disabled		0		dB
		Boost enabled		20		dB
Gain range from AUXL/R or L/R2 input to boost/mixer			-12		+6	dB
Gain step size to boost/mixer				3		dB
<b>Auxilliary Analogue Inputs (AUXL, AUXR)</b>						
Full-scale Input Signal Level (0dB) – note this changes in proportion to AVDD	V <sub>INFS</sub>			AVDD/3.3 0		V <sub>rms</sub> dBV
Input Resistance (Note 2)	R <sub>AUXINLMIN</sub>	Left Input boost and mixer enabled, at max gain		4.3		kΩ
	R <sub>AUXINLTYP</sub>	Left Input boost and mixer enabled, at 0dB gain		8.6		kΩ
	R <sub>AUXINLMAX</sub>	Left Input boost and mixer enabled, at min gain		39.1		kΩ
	R <sub>AUXINRMIN</sub>	Right Input boost, mixer and beep enabled, at max gain		3		kΩ
	R <sub>AUXINRTYP</sub>	Right Input boost, mixer and beep enabled, at 0dB gain		6		kΩ
	R <sub>AUXINRMAX</sub>	Right Input boost, mixer and beep enabled, at min gain		29		kΩ
Input Capacitance	C <sub>MICIN</sub>			10		pF

**Test Conditions**

DCVDD=1.8V, AVDD=DBVDD=SPKVDD= 3.3V, T<sub>A</sub> = +25°C, 1kHz signal, fs = 48kHz, 24-bit audio data unless otherwise stated.

PARAMETER	SYMBOL	TEST CONDITIONS	MIN	TYP	MAX	UNIT
<b>Automatic Level Control (ALC)</b>						
Target Record Level			-22.5		-1.5	dB
Programmable gain			-12		35.25	
Gain Hold Time (Note 3,5)	t <sub>HOLD</sub>	MCLK = 12.288MHz (Note 3)	0, 2.67, 5.33, 10.67, ... , 43691 (time doubles with each step)			ms
Gain Ramp-Up (Decay) Time (Note 4,5)	t <sub>DCY</sub>	ALCMODE=0 (ALC), MCLK=12.288MHz (Note 3)	3.3, 6.6, 13.1, ... , 3360 (time doubles with each step)			ms
		ALCMODE=1 (limiter), MCLK=12.288MHz (Note 3)	0.73, 1.45, 2.91, ... , 744 (time doubles with each step)			
Gain Ramp-Down (Attack) Time (Note 4,5)	t <sub>ATK</sub>	ALCMODE=0 (ALC), MCLK=12.288MHz (Note 3)	0.83, 1.66, 3.33, ... , 852 (time doubles with each step)			ms
		ALCMODE=1 (limiter), MCLK=12.288MHz (Note 3)	0.18, 0.36, 0.73, ... , 186 (time doubles with each step)			
Mute Attenuation				120		dB
<b>Analogue to Digital Converter (ADC)</b>						
Signal to Noise Ratio (Note 6)	SNR	A-weighted, 0dB gain		95		dB
Total Harmonic Distortion (Note 7)	THD	-3dBFS input		-84		dB
Channel Separation (Note 9)		1kHz input signal		110		dB
<b>Digital to Analogue Converter (DAC) to Line-Out (LOUT1, ROUT1 with 10kΩ / 50pF load)</b>						
Full-scale output		PGA gains set to 0dB, OUT34BOOST=0		AVDD/3.3		Vrms
		PGA gains set to 0dB, OUT34BOOST=1		1.5x (AVDD/3.3)		
Signal to Noise Ratio (Note 6)	SNR	A-weighted		98		dB
Total Harmonic Distortion (Note 7)	THD	R <sub>L</sub> = 10kΩ full-scale signal		-84		dB
Channel Separation (Note 8)		1kHz signal		110		dB
<b>Output Mixers (LMX1, RMX1)</b>						
PGA gain range into mixer			-15	0	+6	dB
PGA gain step into mixer				3		dB
<b>Analogue Outputs (LOUT1, ROUT1, LOUT2, ROUT2)</b>						
Programmable Gain range			-57	0	+6	dB
Programmable Gain step size		Monotonic		1		dB
Mute attenuation		1kHz, full scale signal		85		dB
<b>Headphone Output (LOUT1, ROUT1 with 32Ω load)</b>						
0dB full scale output voltage				AVDD/3.3		Vrms
Signal to Noise Ratio	SNR	A-weighted		102		dB
Total Harmonic Distortion	THD	R <sub>L</sub> = 16Ω, Po=20mW AVDD=3.3V		0.003 -92		% dB
		R <sub>L</sub> = 32 Ω, Po=20mW AVDD=3.3V		0.008 - 82		% dB



**Test Conditions**

DCVDD=1.8V, AVDD=DBVDD=SPKVDD= 3.3V, T<sub>A</sub> = +25°C, 1kHz signal, fs = 48kHz, 24-bit audio data unless otherwise stated.

PARAMETER	SYMBOL	TEST CONDITIONS	MIN	TYP	MAX	UNIT
<b>Speaker Output (LOUT2, ROUT2 with 8Ω bridge tied load, INVROUT2=1)</b>						
Full scale output voltage, 0dB gain. (Note 9)		SPKBOOST=0		SPKVDD/3.3		V <sub>rms</sub>
		SPKBOOST=1		(SPKVDD/3.3)*1.5		
Output Power	P <sub>O</sub>	Output power is very closely correlated with THD; see below				
Total Harmonic Distortion	THD	P <sub>O</sub> =200mW, R <sub>L</sub> = 8Ω, SPKVDD=3.3V		0.04 -68		% dB
		P <sub>O</sub> =320mW, R <sub>L</sub> = 8Ω, SPKVDD=3.3V		1.0 -40		% dB
		P <sub>O</sub> =500mW, R <sub>L</sub> = 8Ω, SPKVDD=5V		0.02 -74		% dB
		P <sub>O</sub> =860mW, R <sub>L</sub> = 8Ω, SPKVDD=5V		1.0 -40		% dB
Signal to Noise Ratio	SNR	SPKVDD=3.3V, R <sub>L</sub> = 8Ω		90		dB
		SPKVDD=5V, R <sub>L</sub> = 8Ω		90		dB
Power Supply Rejection Ratio (50Hz-22kHz)	PSRR	R <sub>L</sub> = 8Ω BTL		80		dB
		R <sub>L</sub> = 8Ω BTL SPKVDD=5V (boost)		69		dB
<b>OUT3/OUT4 Outputs (with 10kΩ / 50pF load)</b>						
Full-scale output voltage, 0dB gain (Note 10)		OUT3BOOST=0/ OUT4BOOST=0		SPKVDD/3.3		V <sub>rms</sub>
		OUT3BOOST=1 OUT4BOOST=1		(SPKVDD/3.3)*1.5		V <sub>rms</sub>
Signal to Noise Ratio (Note 6)	SNR	A-weighted		98		dB
Total Harmonic Distortion (Note 7)	THD	R <sub>L</sub> = 10 kΩ full-scale signal		-84		dB
Channel Separation (Note 8)		1kHz signal		100		dB
Power Supply Rejection Ratio (50Hz-22kHz)	PSRR	R <sub>L</sub> = 10kΩ		52		dB
		R <sub>L</sub> = 10kΩ SPKVDD=5V (boost)		56		dB
<b>Microphone Bias</b>						
Bias Voltage	V <sub>MICBIAS</sub>	MBVSEL=0		0.9*AVDD		V
		MBVSEL=1		0.65*AVDD		V
Bias Current Source	I <sub>MICBIAS</sub>				3	mA
Output Noise Voltage	V <sub>n</sub>	1K to 20kHz		15		nV/√Hz
<b>Digital Input / Output</b>						
Input HIGH Level	V <sub>IH</sub>		0.7×DBVDD			V
Input LOW Level	V <sub>IL</sub>				0.3×DBVDD	V
Output HIGH Level	V <sub>OH</sub>	I <sub>OL</sub> =1mA	0.9×DBVDD			V
Output LOW Level	V <sub>OL</sub>	I <sub>OH</sub> =1mA			0.1×DBVDD	V
Input capacitance				TBD		pF
Input leakage				TBD		pA

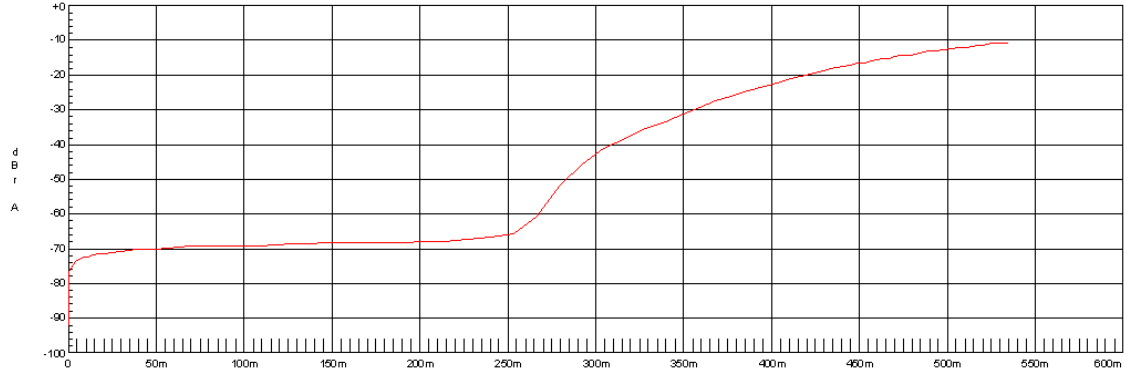
## TERMINOLOGY

1. Input level to RIP and LIP is limited to a maximum of -3dB or THD+N performance will be reduced.
2. Note when BEEP path is not enabled then AUXL and AUXR have the same input impedances.
3. Hold Time is the length of time between a signal detected being too quiet and beginning to ramp up the gain. It does not apply to ramping down the gain when the signal is too loud, which happens without a delay.
4. Ramp-up and Ramp-Down times are defined as the time it takes for the PGA to sweep across 90% of its gain range.
5. All hold, ramp-up and ramp-down times scale proportionally with MCLK
6. Signal-to-noise ratio (dB) – SNR is a measure of the difference in level between the full scale output and the output with no signal applied. (No Auto-zero or Automute function is employed in achieving these results).
7. THD+N (dB) – THD+N is a ratio, of the rms values, of (Noise + Distortion)/Signal.
8. Channel Separation (dB) – Also known as Cross-Talk. This is a measure of the amount one channel is isolated from the other. Measured by applying a full scale signal to one channel input and measuring the level of signal apparent at the other channel output.
9. The maximum output voltage can be limited by the speaker power supply. If OUT3BOOST, OUT4BOOST or SPKBOOST is set then SPKVDD should be 1.5xAVDD to prevent clipping taking place in the output stage (when PGA gains are set to 0dB).

### SPEAKER OUTPUT THD VERSUS POWER

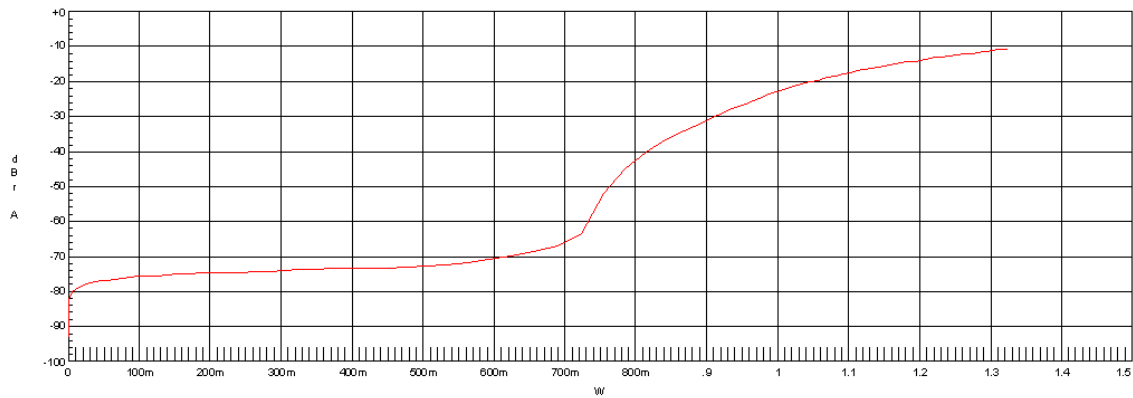
Wolfson Microelectronics plc

L/ROUT2 to 8R BTL THD+NvPo



Wolfson Microelectronics plc

WM8978 L/ROUT2 to 8R BTL THD+NvPo



## POWER CONSUMPTION

Typical current consumption for various scenarios is shown below.

MODE	AVDD (3.0V) (mA)	DCVDD (1.8V) (mA)	DBVDD <sup>1</sup> (3.0V) (mA)	TOTAL POWER (mW)
Off	0.04 <sup>3</sup>	0.0008	<0.0001	0.12
Sleep (VREF maintained, no clocks)	0.04	0.0008	<0.0001	0.12
Stereo Record (8kHz) <sup>2</sup>	4.1	1.0	0.001	14.1
Stereo 16Ω HP Playback (44.1kHz, quiescent) <sup>2</sup>	3.3	6.2	0.004	21.1
Stereo 16Ω HP Playback (44.1kHz, white noise) <sup>2</sup>	5.4	7.3	0.004	29.4
Stereo 16Ω HP Playback (44.1kHz, sine wave) <sup>2</sup>	18	6.7	0.004	66.1

### Notes:

1. DBVDD Current will increase with greater loading on digital I/O pins.
2. 5 Band EQ is enabled.
3. AVDD standby current will fall to nearer 15uA when thermal shutdown sensor is disabled.

**Table 1 Power Consumption**

### ESTIMATING SUPPLY CURRENT

When either the DAC or ADC is enabled approximately 7mA will be drawn from DCVDD when DCVDD=1.8V and fs=48kHz. When the PLL is enabled approximately 1.5mA additional current will be drawn from DCVDD.

As a general rule, digital supply currents will scale in proportion to sample rates. Supply current for analogue and digital blocks will also be lower at lower supply voltages.

Power consumed by the output drivers will depend greatly on the signal characteristics. A quiet signal, or a signal with long periods of silence will consume less power than a signal which is continuously loud.

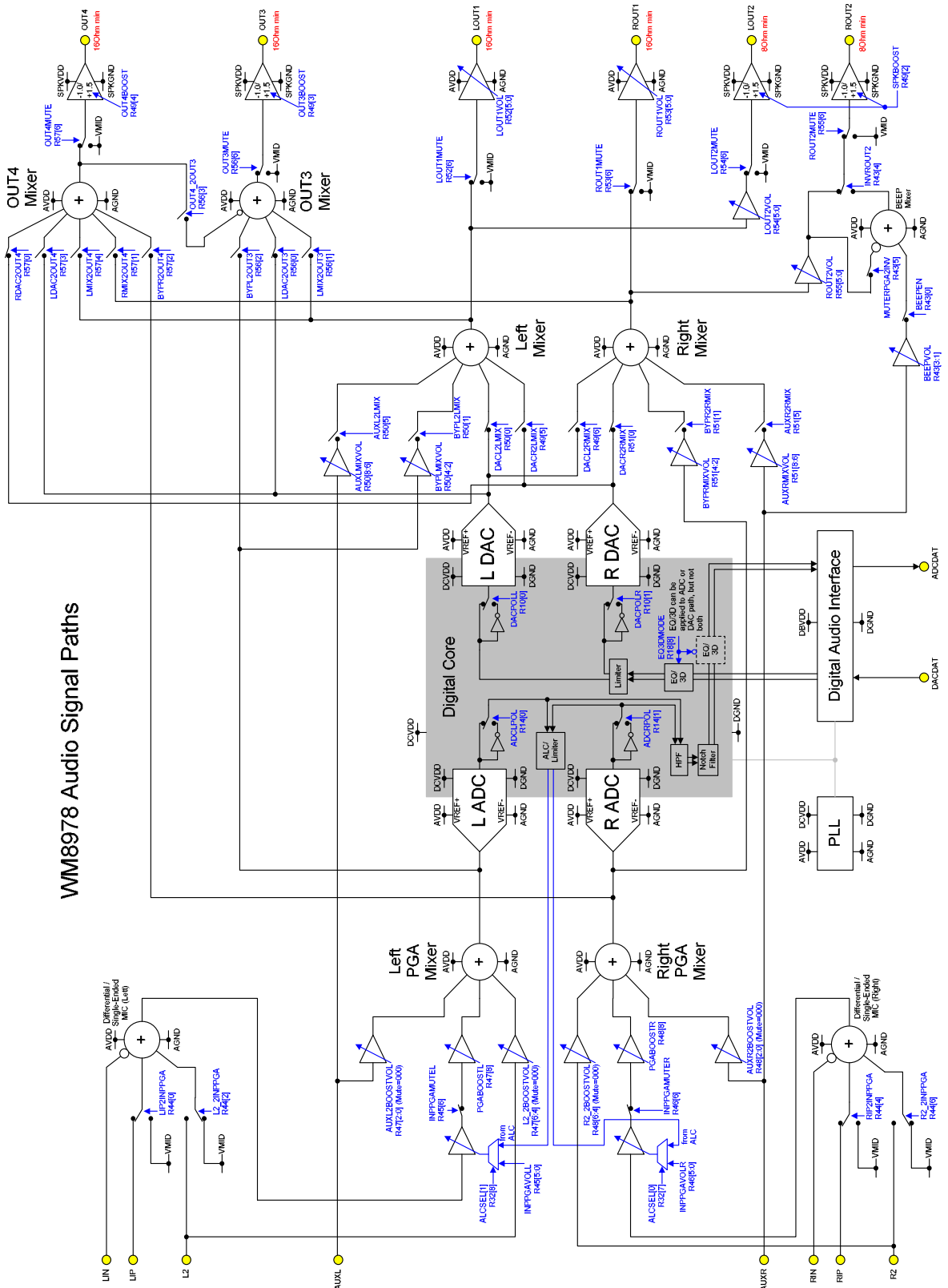
Estimated supply current for the analogue blocks is shown in Table 2. Note that power dissipated in the load is not shown.

REGISTER BIT	AVDD CURRENT (mA) AVDD=3.3V
BUFDCOPEN	0.1
OUT4MIXEN	0.2
OUT3MIXEN	0.2
PLLEN	1.2 (with clocks applied)
MICBEN	0.5
BIASEN	0.3
BUFIOEN	0.1
VMIDSEL	5K $\Omega$ = >0.3, less than 0.1 for 75K $\Omega$ 300K $\Omega$ settings
ROUT1EN	0.4
LOUT1EN	0.4
BOOSTENR	0.2
BOOSTENL	0.2
INPPGAENR	0.2
INPPGAENL	0.2
ADCENR	2.6 (x64, ADCOSR=0) 4.9 ( x128, ADCOSR=1)
ADCENL	2.6 (x64, ADCOSR=0) 4.9 ( x128, ADCOSR=1)
OUT4EN	0.2
OUT3EN	0.2
LOUT2EN	1mA from SPKVDD + 0.2mA from AVDD in 5V mode
ROUT2EN	1mA from SPKVDD + 0.2mA from AVDD in 5V mode
RMIXEN	0.2
LMIXEN	0.2
DACENR	1.8 (x64, DACOSR=0) 1.9 (x128, DACOSR=1)
DACENL	1.8 (x64, DACOSR=0) 1.9 (x128, DACOSR=1)

Table 2 AVDD Supply Current (AVDD=3.3V)

AUDIO PATHS OVERVIEW

WM8978 Audio Signal Paths



## SIGNAL TIMING REQUIREMENTS

### SYSTEM CLOCK TIMING

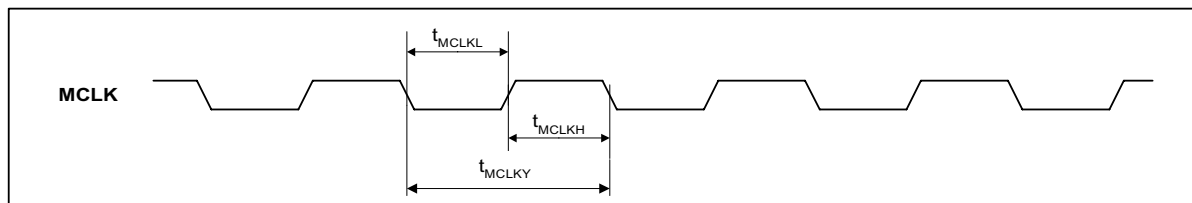


Figure 1 System Clock Timing Requirements

#### Test Conditions

DCVDD=1.8V, DBVDD=AVDD=SPKVDD=3.3V, DGND=AGND=SPKGND=0V, T<sub>A</sub> = +25°C

PARAMETER	SYMBOL	CONDITIONS	MIN	TYP	MAX	UNIT
<b>System Clock Timing Information</b>						
MCLK cycle time	T <sub>MCLKY</sub>	MCLK=SYSCLK (=256fs)	81.38			ns
		MCLK input to PLL <sup>Note 1</sup>	20			ns
MCLK duty cycle	T <sub>MCLKDS</sub>		60:40		40:60	

#### Note 1:

PLL pre-scaling and PLL N and K values should be set appropriately so that SYSCLK is no greater than 12.288MHz.

### AUDIO INTERFACE TIMING – MASTER MODE

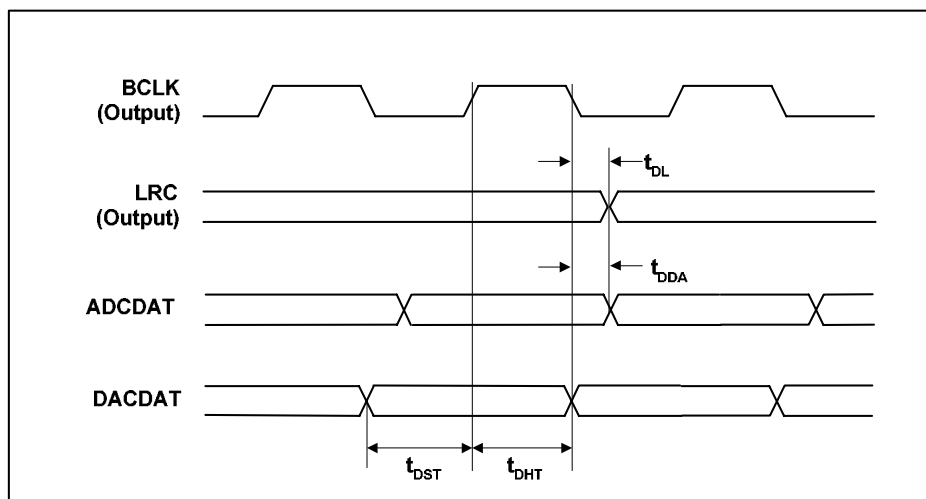


Figure 2 Digital Audio Data Timing – Master Mode (see Control Interface)

**Test Conditions**

DCVDD=1.8V, DBVDD=AVDD=SPKVDD=3.3V, DGND=AGND=SPKGND=0V,  $T_A=+25^{\circ}\text{C}$ , Master Mode,  $f_s=48\text{kHz}$ , MCLK=256fs, 24-bit data, unless otherwise stated.

PARAMETER	SYMBOL	MIN	TYP	MAX	UNIT
<b>Audio Data Input Timing Information</b>					
LRC propagation delay from BCLK falling edge	$t_{DL}$			10	ns
ADCDAT propagation delay from BCLK falling edge	$t_{DDA}$			10	ns
DACDAT setup time to BCLK rising edge	$t_{DST}$	10			ns
DACDAT hold time from BCLK rising edge	$t_{DHT}$	10			ns

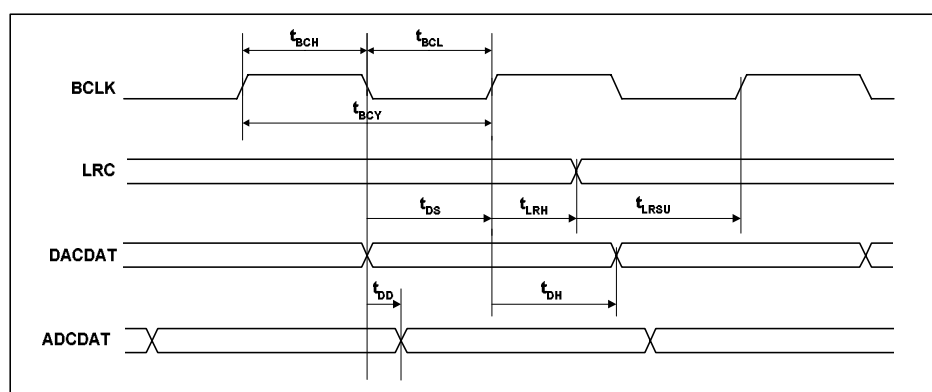
**AUDIO INTERFACE TIMING – SLAVE MODE**

Figure 3 Digital Audio Data Timing – Slave Mode

**Test Conditions**

DCVDD=1.8V, DBVDD=AVDD=SPKVDD=3.3V, DGND=AGND=SPKGND=0V,  $T_A=+25^{\circ}\text{C}$ , Slave Mode,  $f_s=48\text{kHz}$ , MCLK= 256fs, 24-bit data, unless otherwise stated.

PARAMETER	SYMBOL	MIN	TYP	MAX	UNIT
<b>Audio Data Input Timing Information</b>					
BCLK cycle time	$t_{BCY}$	50			ns
BCLK pulse width high	$t_{BCH}$	20			ns
BCLK pulse width low	$t_{BCL}$	20			ns
LRC set-up time to BCLK rising edge	$t_{LRSU}$	10			ns
LRC hold time from BCLK rising edge	$t_{LRH}$	10			ns
DACDAT hold time from BCLK rising edge	$t_{DH}$	10			ns
DACDAT set-up time to BCLK rising edge	$t_{Ds}$	10			ns
ADCDAT propagation delay from BCLK falling edge	$t_{DD}$			10	ns

**Note:**

BCLK period should always be greater than or equal to MCLK period.



## CONTROL INTERFACE TIMING – 3-WIRE MODE

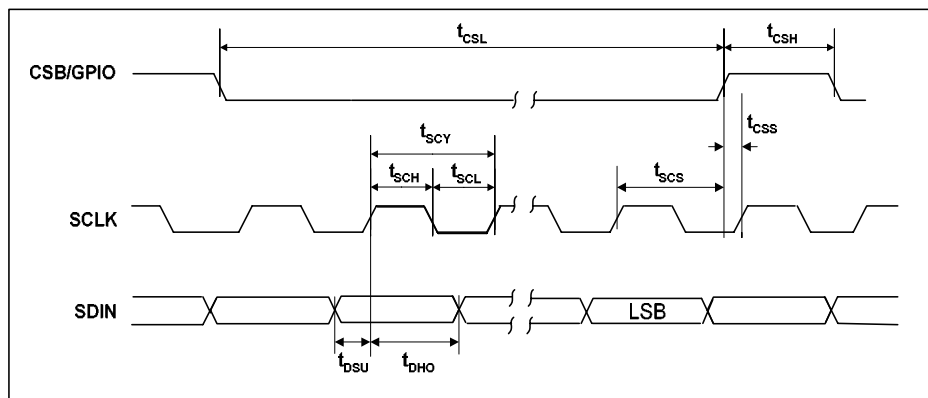


Figure 4 Control Interface Timing – 3-Wire Serial Control Mode

## Test Conditions

DCVDD = 1.8V, DBVDD = AVDD = SPKVDD = 3.3V, DGND = AGND = SPKGND = 0V,  $T_A = +25^\circ\text{C}$ , Slave Mode,  $f_s = 48\text{kHz}$ , MCLK = 256fs, 24-bit data, unless otherwise stated.

PARAMETER	SYMBOL	MIN	TYP	MAX	UNIT
<b>Program Register Input Information</b>					
SCLK rising edge to CSB rising edge	$t_{SCS}$	80			ns
SCLK pulse cycle time	$t_{SCY}$	200			ns
SCLK pulse width low	$t_{SCL}$	80			ns
SCLK pulse width high	$t_{SCH}$	80			ns
SDIN to SCLK set-up time	$t_{DSU}$	40			ns
SCLK to SDIN hold time	$t_{DHO}$	40			ns
CSB pulse width low	$t_{CSL}$	40			ns
CSB pulse width high	$t_{CSH}$	40			ns
CSB rising to SCLK rising	$t_{CSS}$	40			ns
Pulse width of spikes that will be suppressed	$t_{ps}$	0		5	ns

## CONTROL INTERFACE TIMING – 2-WIRE MODE

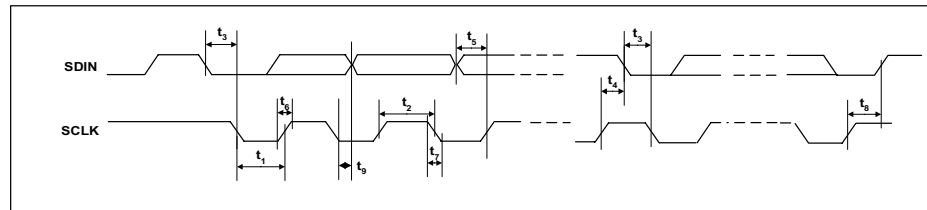


Figure 5 Control Interface Timing – 2-Wire Serial Control Mode

## Test Conditions

DCVDD=1.8V, DBVDD=AVDD=SPKVDD=3.3V, DGND=AGND=SPKGND=0V,  $T_A=+25^{\circ}\text{C}$ , Slave Mode,  $f_s=48\text{kHz}$ , MCLK = 256fs, 24-bit data, unless otherwise stated.

PARAMETER	SYMBOL	MIN	TYP	MAX	UNIT
<b>Program Register Input Information</b>					
SCLK Frequency		0		526	kHz
SCLK Low Pulse-Width	$t_1$	1.3			us
SCLK High Pulse-Width	$t_2$	600			ns
Hold Time (Start Condition)	$t_3$	600			ns
Setup Time (Start Condition)	$t_4$	600			ns
Data Setup Time	$t_5$	100			ns
SDIN, SCLK Rise Time	$t_6$			300	ns
SDIN, SCLK Fall Time	$t_7$			300	ns
Setup Time (Stop Condition)	$t_8$	600			ns
Data Hold Time	$t_9$			900	ns
Pulse width of spikes that will be suppressed	$t_{ps}$	0		5	ns

## INTERNAL POWER ON RESET CIRCUIT

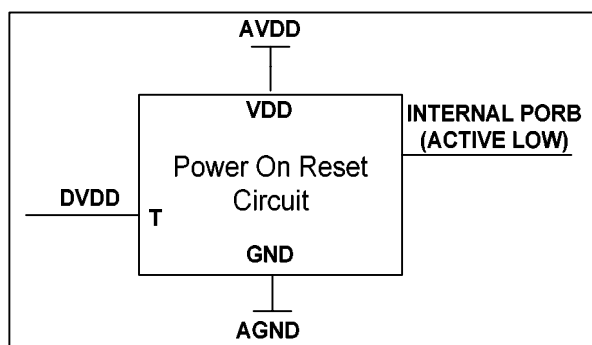


Figure 6 Internal Power on Reset Circuit Schematic

The WM8978 includes an internal Power-On-Reset Circuit (POR), as shown in Figure 6, which is used to reset the digital logic into a default state after power up. The POR circuit is powered from AVDD and monitors DVDD. It asserts PORB low if AVDD or DVDD is below a minimum threshold.

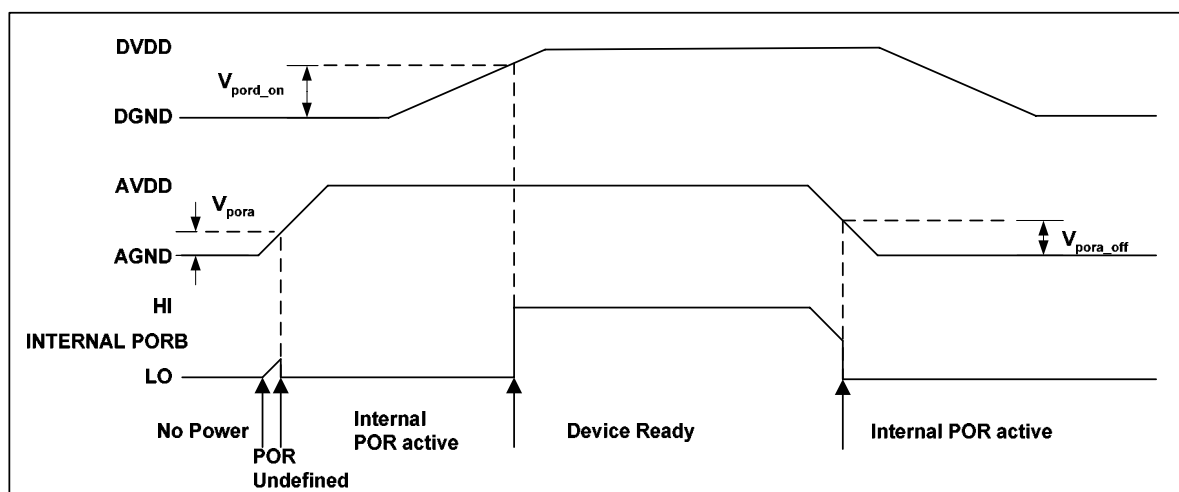


Figure 7 Typical Power up Sequence where AVDD is Powered before DVDD

Figure 7 shows a typical power-up sequence where AVDD comes up first. When AVDD goes above the minimum threshold,  $V_{pora}$ , there is enough voltage for the circuit to guarantee PORB is asserted low and the chip is held in reset. In this condition, all writes to the control interface are ignored. AVDD will then ramp up to full supply level. Next DVDD rises to  $V_{pord\_on}$  and PORB is released high and all registers are in their default state and writes to the control interface may take place.

On power down, where AVDD falls first, PORB is asserted low whenever AVDD drops below the minimum threshold  $V_{pora\_off}$ .

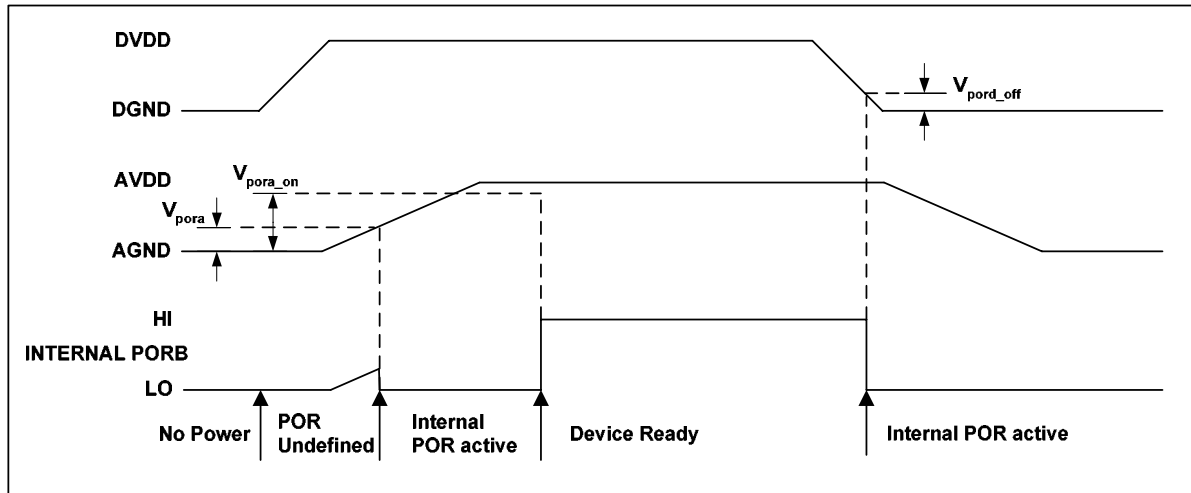


Figure 8 Typical Power up Sequence where DVDD is Powered before AVDD

Figure 8 shows a typical power-up sequence where DVDD comes up first. First it is assumed that DVDD is already up to specified operating voltage. When AVDD goes above the minimum threshold,  $V_{pora}$ , there is enough voltage for the circuit to guarantee PORB is asserted low and the chip is held in reset. In this condition, all writes to the control interface are ignored. When AVDD rises to  $V_{pora\_on}$ , PORB is released high and all registers are in their default state and writes to the control interface may take place.

On power down, where DVDD falls first, PORB is asserted low whenever DVDD drops below the minimum threshold  $V_{pord\_off}$ .

SYMBOL	MIN	TYP	MAX	UNIT
$V_{pora}$	0.4	0.6	0.8	V
$V_{pora\_on}$	0.9	1.2	1.6	V
$V_{pora\_off}$	0.4	0.6	0.8	V
$V_{pord\_on}$	0.5	0.7	0.9	V
$V_{pord\_off}$	0.4	0.6	0.8	V

Table 3 Typical POR operation (typical simulated values)

Notes:

1. If AVDD and DVDD suffer a brown-out (i.e. drop below the minimum recommended operating level but do not go below  $V_{pora\_off}$  or  $V_{pord\_off}$ ) then the chip will not reset and will resume normal operation when the voltage is back to the recommended level again.
2. The chip will enter reset at power down when AVDD or DVDD falls below  $V_{pora\_off}$  or  $V_{pord\_off}$ . This may be important if the supply is turned on and off frequently by a power management system.
3. The minimum  $t_{por}$  period is maintained even if DVDD and AVDD have zero rise time. This specification is guaranteed by design rather than test.

## RECOMMENDED POWER UP/DOWN SEQUENCE

In order to minimise output pop and click noise, it is recommended that the WM8978 device is powered up and down using one of the following sequences:

Power-up when NOT using the output 1.5x boost stage:

1. Turn on external power supplies. Wait for supply voltage to settle.
2. Mute all analogue outputs.
3. Set L/RMIXEN = 1 and DACENL/R = 1 in register R3.
4. Set BUFIOEN = 1 and VMIDSEL[1:0] to required value in register R1. Wait for the VMID supply to settle. \*Refer notes 1 and 2.
5. Set BIASEN = 1 in register R1.
6. Set L/ROUT1EN = 1 in register R2.
7. Enable other mixers as required.
8. Enable other outputs as required.
9. Set remaining registers.

Power-up when using the output 1.5x boost stage:

1. Turn on external power supplies. Wait for supply voltage to settle.
2. Mute all analogue outputs.
3. Enable unused output chosen from L/ROUT2, OUT3 or OUT4. If unused output not available, chose one of these outputs not required at power up.
4. Set BUFDCOPEN = 1 and BUFIOEN = 1 in register R1.
5. Set SPKBOOST = 1 in register R49.
6. Set VMIDSEL[1:0] to required value in register R1. Wait for the VMID supply to settle. \*Refer notes 1 and 2.
7. Set L/RMIXEN = 1 and DACENL/R = 1 in register R3.
8. Set BIASEN = 1 in register R1.
9. Set L/ROUT2EN = 1 in register R3. \*Note 3.
10. Enable other mixers as required.
11. Enable other outputs as required.
12. Set remaining registers.

Power Down (all cases):

1. Mute all analogue outputs.
2. Disable Power Management Register 1. R1 = 0x00.
3. Disable Power Management Register 2. R2 = 0x00.
4. Disable Power Management Register 3. R3 = 0x00.
5. Remove external power supplies.

**Notes:**

1. This step enables the internal device bias buffer and the VMID buffer for unassigned inputs/outputs. This will provide a startup reference voltage for all inputs and outputs. This will cause the inputs and outputs to ramp towards VMID (NOT using output 1.5x boost) or 1.5 x (AVDD/2) (using output 1.5x boost) in a way that is controlled and predictable (see note 2).
2. Choose the value of the VMIDSEL bits based on the startup time (VMIDSEL=10 for slowest startup, VMIDSEL=11 for fastest startup). Startup time is defined by the value of the VMIDSEL bits (the reference impedance) and the external decoupling capacitor on VMID.
3. Setting DACEN to off while operating in x1.5 boost mode will cause the VMID voltage to drop to AVDD/2 midrail level and cause an output pop.

In addition to the power on sequence, it is recommended that the zero cross functions are used when changing the volume in the PGAs to avoid any audible pops or clicks.

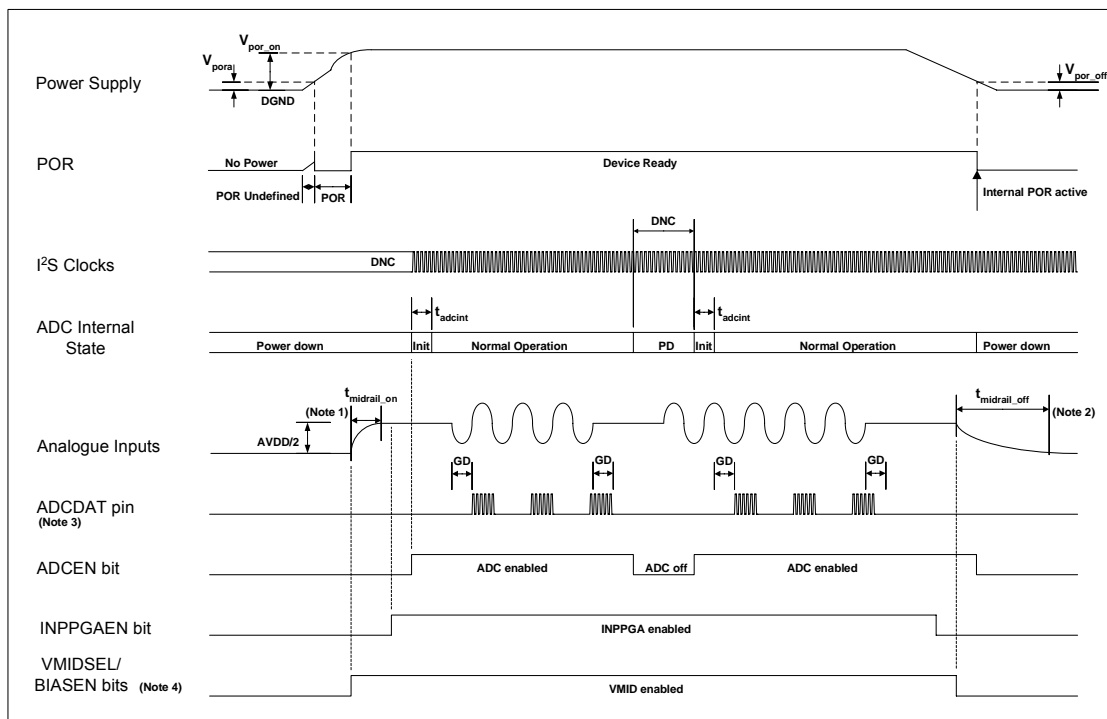


Figure 9 ADC Power Up and Down Sequence (not to scale)

SYMBOL	MIN	TYPICAL	MAX	UNIT
$t_{midrail\_on}$		500		ms
$t_{midrail\_off}$		>10		s
$t_{adcint}$		2/fs		n/fs
ADC Group Delay		29/fs		n/fs

Table 4 Typical POR Operation (typical simulated values)

**Notes:**

1. The analogue input pin charge time,  $t_{\text{midrail\_on}}$ , is determined by the VMID pin charge time. This time is dependent upon the value of VMID decoupling capacitor and VMID pin input resistance and AVDD power supply rise time.
2. The analogue input pin discharge time,  $t_{\text{midrail\_off}}$ , is determined by the analogue input coupling capacitor discharge time. The time,  $t_{\text{midrail\_off}}$ , is measured using a  $1\mu\text{F}$  capacitor on the analogue input but will vary dependent upon the value of input coupling capacitor.
3. While the ADC is enabled there will be LSB data bit activity on the ADCDAT pin due to system noise but no significant digital output will be present.
4. The VMIDSEL and BIASEN bits must be set to enable analogue input midrail voltage and for normal ADC operation.
5. ADCDAT data output delay from power up - with power supplies starting from 0V - is determined primarily by the VMID charge time. ADC initialisation and power management bits may be set immediately after POR is released; VMID charge time will be significantly longer and will dictate when the device is stabilised for analogue input.
6. ADCDAT data output delay at power up from device standby (power supplies already applied) is determined by ADC initialisation time,  $2/f_s$ .

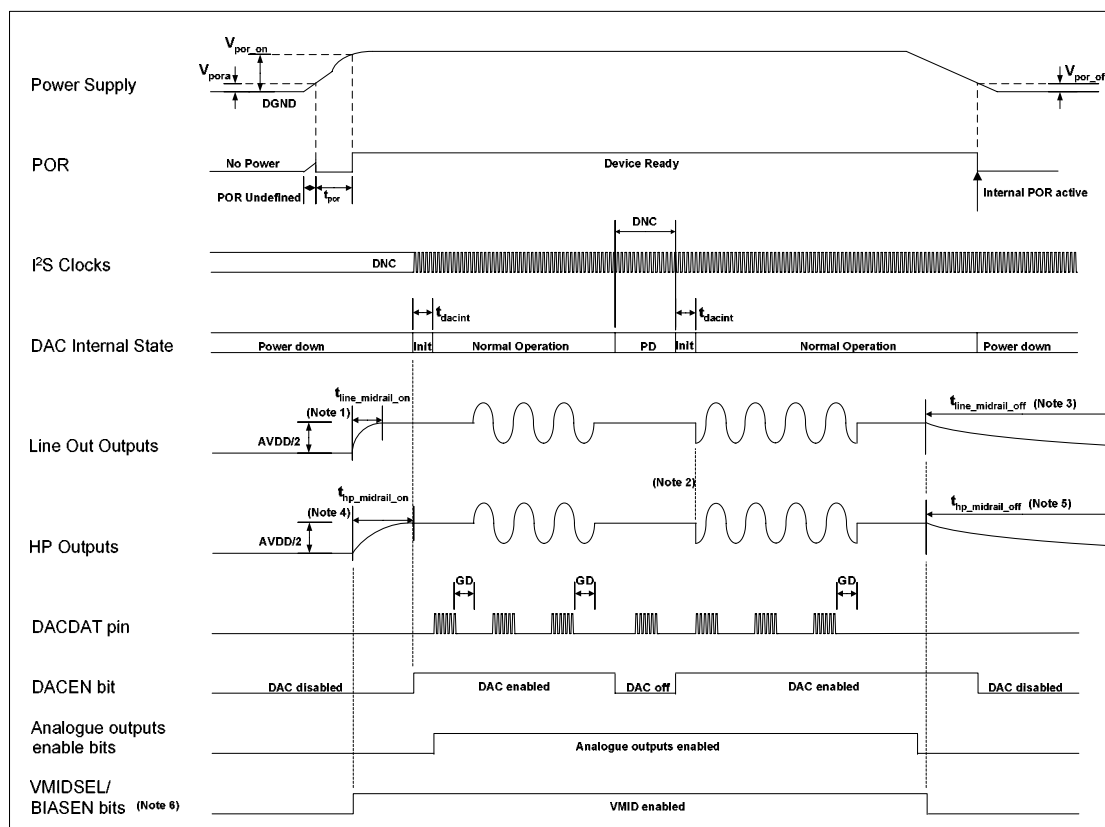


Figure 10 DAC Power Up and Down Sequence (not to scale)

SYMBOL	MIN	TYPICAL	MAX	UNIT
$t_{line\_midrail\_on}$		500		ms
$t_{line\_midrail\_off}$		1		s
$t_{hp\_midrail\_on}$		500		ms
$t_{hp\_midrail\_off}$		6		s
$t_{dacint}$		2/fs		n/fs
DAC Group Delay		29/fs		n/fs

**Table 5 Typical POR Operation (typical simulated values)**

**Notes:**

1. The lineout charge time,  $t_{line\_midrail\_on}$ , is mainly determined by the VMID pin charge time. This time is dependent upon the value of VMID decoupling capacitor and VMID pin input resistance and AVDD power supply rise time. The values above were measured using a 4.7 $\mu$ F capacitor.
2. It is not advisable to allow DACDAT data input during initialisation of the DAC. If the DAC data value is not zero at point of initialisation, then this is likely to cause a pop noise on the analogue outputs. The same is also true if the DACDAT is removed at a non-zero value, and no mute function has been applied to the signal beforehand.
3. The lineout discharge time,  $t_{line\_midrail\_off}$ , is dependent upon the value of the lineout coupling capacitor and the leakage resistance path to ground. The values above were measured using a 10 $\mu$ F output capacitor.
4. The headphone charge time,  $t_{hp\_midrail\_on}$ , is dependent upon the value of VMID decoupling capacitor and VMID pin input resistance and AVDD power supply rise time. The values above were measured using a 4.7 $\mu$ F VMID decoupling capacitor.
5. The headphone discharge time,  $t_{hp\_midrail\_off}$ , is dependent upon the value of the headphone coupling capacitor and the leakage resistance path to ground. The values above were measured using a 100 $\mu$ F capacitor.
6. The VMIDSEL and BIASEN bits must be set to enable analogue output midrail voltage and for normal DAC operation.



## DEVICE DESCRIPTION

### INTRODUCTION

The WM8978 is a low power audio CODEC combining a high quality stereo audio DAC and ADC, with flexible line and microphone input and output processing. Applications for this device include multimedia phones, stereo digital camcorders, and digital still cameras with either mono or stereo record and playback capability.

### FEATURES

The chip offers great flexibility in use, and so can support many different modes of operation as follows:

#### MICROPHONE INPUTS

Two pairs of stereo microphone inputs are provided, allowing a pair of stereo microphones to be pseudo-differentially connected, with user defined gain using internal resistors. The provision of the common mode input pin for each stereo input allows for rejection of common mode noise on the microphone inputs (level depends on gain setting chosen). A microphone bias is output from the chip which can be used to bias both microphones. The signal routing can be configured to allow manual adjustment of mic levels, or to allow the ALC loop to control the level of mic signal that is transmitted.

Total gain through the microphone paths of up to +55.25dB can be selected.

#### PGA AND ALC OPERATION

A programmable gain amplifier is provided in the input path to the ADC. This may be used manually or in conjunction with a mixed analogue/digital automatic level control (ALC) which keeps the recording volume constant.

#### LINE INPUTS (AUXL, AUXR)

The inputs, AUXL and AUXR, can be used as a stereo line input or as an input for warning tones (or 'beeps') etc. These inputs can be summed into the record paths, along with the microphone preamp outputs, so allowing for mixing of audio with 'backing music' etc as required.

#### ADC

The stereo ADC uses a 24-bit delta sigma oversampling architecture to deliver optimum performance with low power consumption.

#### HI-FI DAC

The hi-fi DAC provides high quality audio playback suitable for all portable audio hi-fi type applications, including MP3 players and portable disc players of all types.

#### OUTPUT MIXERS

Flexible mixing is provided on the outputs of the device. A stereo mixer is provided for the stereo headphone or line outputs, LOUT1/ROUT1, and additional summers on the OUT3/OUT4 outputs allow for an optional differential or stereo line output on these pins. Gain adjustment PGAs are provided for the LOUT1/ROUT1 and LOUT2/ROUT2 outputs, and signal switching is provided to allow for all possible signal combinations. The output buffers can be configured in several ways, allowing support of up to three sets of external transducers; ie stereo headphone, BTL speaker, and BTL earpiece may be connected simultaneously. Thermal implications should be considered before simultaneous full power operation of all outputs is attempted.

Alternatively, if a speaker output is not required, the LOUT2 and ROUT2 pins might be used as a stereo headphone driver, (disable output invert buffer on ROUT2). In that case two sets of headphones might be driven, or the LOUT2 and ROUT2 pins used as a line output driver.

OUT3 and OUT4 can be configured to provide an additional stereo lineout from the output of the DACs, the mixers or the input microphone boost stages. Alternatively OUT4 can be configured as a mono mix of left and right DACs or mixers, or simply a buffered version of the chip midrail reference voltage. OUT3 can also be configured as a buffered VMID output. This voltage may then be used as a headphone 'pseudo ground' allowing removal of the large AC coupling capacitors often used in the output path.

### AUDIO INTERFACES

The WM8978 has a standard audio interface, to support the transmission of stereo data to and from the chip. This interface is a 3 wire standard audio interface which supports a number of audio data formats including I2S, DSP/PCM Mode (a burst mode in which LRC sync plus 2 data packed words are transmitted), MSB-First, left justified and MSB-First, right justified, and can operate in master or slave modes.

### CONTROL INTERFACES

To allow full software control over all features, the WM8978 offers a choice of 2 or 3 wire control interface. It is fully compatible and an ideal partner for a wide range of industry standard microprocessors, controllers and DSPs.

Selection between the modes is via the MODE pin. In 2 wire mode the address of the device is fixed as 0011010.

### CLOCKING SCHEMES

WM8978 offers the normal audio DAC clocking scheme operation, where 256fs MCLK is provided to the DAC and ADC.

A PLL is included which may be used to generate these clocks in the event that they are not available from the system controller. This PLL uses an input clock, typically the 12MHz USB or iLink clock, to generate high quality audio clocks. If this PLL is not required for generation of these clocks, it can be reconfigured to generate alternative clocks which may then be output on the GPIO pins and used elsewhere in the system.

### POWER CONTROL

The design of the WM8978 has given much attention to power consumption without compromising performance. It operates at very low voltages, and includes the ability to power off any unused parts of the circuitry under software control, and includes standby and power off modes.

### OPERATION SCENARIOS

Flexibility in the design of the WM8978 allows for a wide range of operational scenarios, some of which are proposed below:

Multimedia phone; High quality playback to a stereo headset, a mono ear speaker or a loudspeaker is supported, allowing Hi-Fi playback to be mixed with voice and other analogue inputs while simultaneously transmitting a differential output from the microphone amplifier. A 5-band EQ enables Hi-Fi playback to be customised to suit the user's preferences and the music style, while programmable filtering allows fixed-frequency noise (e.g. 217Hz) to be reduced in the digital domain.

Stereo Camcorder; The provision of two stereo microphone preamplifiers, allows support for both internal and external microphones. All drivers for speaker, headphone and line output connections are integrated. The selectable 'application filters' after the ADC provide for features such as 'wind noise' reduction, or mechanical noise reducing filters.

Stereo Digital still camera recording; Support for digital stereo recording is similar to the camcorder case. But additionally if the DSC supports MP3 playback, and perhaps recording, the ability of the ADCs to support full 48ks/s high quality stereo recording increases device flexibility.

Mono Digital still camera; Full control over device functionality, and power control is provided, allowing for the case of mono DSC recording, when half of the ADC and mic and line functionality may be disabled to save power. In the mono case, the single ADC channel of audio data is sent out over both Left and Right channels of the audio interface when normal I2S type interface format is

used. In the case where DSP mode is used, and mono data is being sent, only the signal channel of mono data is sent.

### AUXILIARY ANALOGUE INPUTS

An analogue stereo FM tuner or other auxiliary analogue input can be connected to the Line inputs of WM8978, and the stereo signal listened to via headphones, or recorded, simultaneously if required.

### INPUT SIGNAL PATH

The WM8978 has a number of flexible analogue inputs. There are two input channels, Left and Right, each of which consists of an input PGA stage followed by a boost/mix stage which drives into the hi-fi ADC. Each input path has three input pins which can be configured in a variety of ways to accommodate single-ended, differential or dual differential microphones. There are two auxiliary input pins which can be fed into to the input boost/mix stage as well as driving into the output path. A bypass path exists from the output of the boost/mix stage into the output left/right mixers.

### MICROPHONE INPUTS

The WM8978 can accommodate a variety of microphone configurations including single ended and differential inputs. The inputs to the left differential input PGA are LIN, LIP and L2. The inputs to the right differential input PGA are RIN, RIP and R2.

In single-ended microphone input configuration the microphone signal should be input to LIN or RIN and the internal NOR gate configured to clamp the non-inverting input of the input PGA to VMID.

In differential mode the larger signal should be input to LIP or RIP and the smaller (e.g. noisy ground connection) should be input to LIN or RIN.

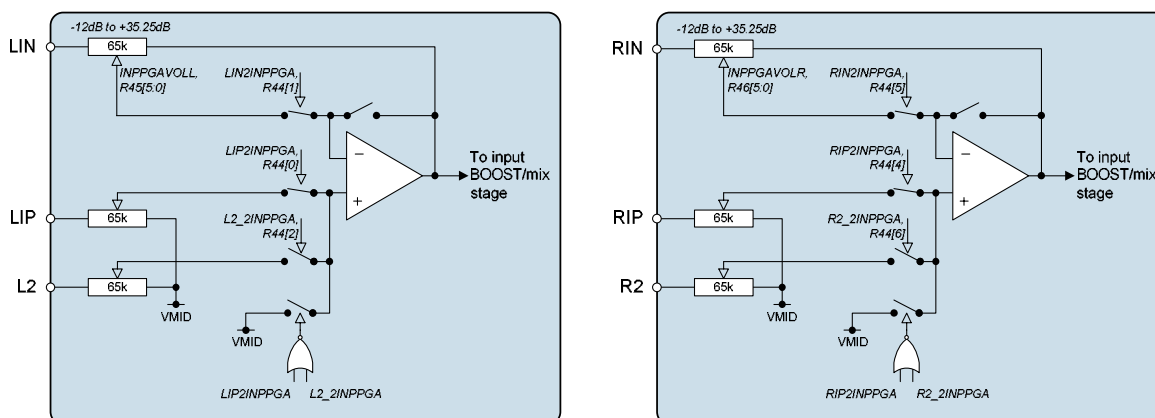


Figure 11 Microphone Input PGA Circuit

The input PGAs are enabled by the IPPGAENL/R register bits.

REGISTER ADDRESS	BIT	LABEL	DEFAULT	DESCRIPTION
R2 Power Management 2	2	INPPGAENL	0	Left channel input PGA enable 0 = disabled 1 = enabled
	3	INPPGAENR	0	Right channel input PGA enable 0 = disabled 1 = enabled

**Table 6 Input PGA Enable Register Settings**

REGISTER ADDRESS	BIT	LABEL	DEFAULT	DESCRIPTION
R44 Input Control	0	LIP2INPPGA	1	Connect LIP pin to left channel input PGA amplifier positive terminal. 0 = LIP not connected to input PGA 1 = input PGA amplifier positive terminal connected to LIP (constant input impedance)
	1	LIN2INPPGA	1	Connect LIN pin to left channel input PGA negative terminal. 0=LIN not connected to input PGA 1=LIN connected to input PGA amplifier negative terminal.
	2	L2_2INPPGA	0	Connect L2 pin to left channel input PGA positive terminal. 0=L2 not connected to input PGA 1=L2 connected to input PGA amplifier positive terminal (constant input impedance).
	4	RIP2INPPGA	1	Connect RIP pin to right channel input PGA amplifier positive terminal. 0 = RIP not connected to input PGA 1 = right channel input PGA amplifier positive terminal connected to RIP (constant input impedance)
	5	RIN2INPPGA	1	Connect RIN pin to right channel input PGA negative terminal. 0=RIN not connected to input PGA 1=RIN connected to right channel input PGA amplifier negative terminal.
	6	R2_2INPPGA	0	Connect R2 pin to right channel input PGA positive terminal. 0=R2 not connected to input PGA 1=R2 connected to input PGA amplifier positive terminal (constant input impedance).

**Table 7 Input PGA Control**

### INPUT PGA VOLUME CONTROLS

The input microphone PGAs have a gain range from -12dB to +35.25dB in 0.75dB steps. The gain from the LIN/RIN input to the PGA output and from the L2/R2 amplifier to the PGA output are always common and controlled by the register bits INPPGAVOLL/R[5:0]. These register bits also affect the LIP pin when LIP2INPPGA=1, the L2 pin when L2\_2INPPGA=1, the RIP pin when RIP2INPPGA=1 and the R2 pin when R2\_2INPPGA=1.

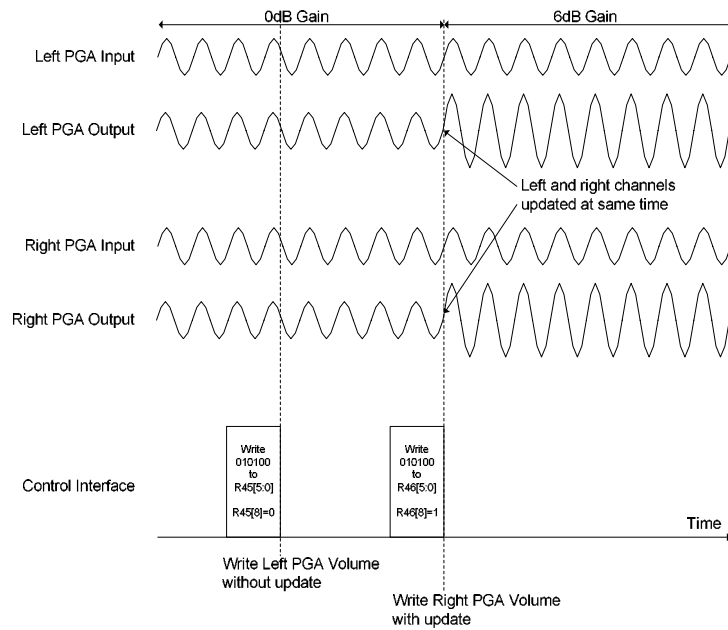
When the Automatic Level Control (ALC) is enabled the input PGA gains are controlled automatically and the INPPGAVOLL/R bits should not be used.

REGISTER ADDRESS	BIT	LABEL	DEFAULT	DESCRIPTION
R45 Left channel input PGA volume control	5:0	INPPGAVOLL	010000	Left channel input PGA volume 000000 = -12dB 000001 = -11.25db . 010000 = 0dB . 111111 = 35.25dB
	6	INPPGAMUTEL	0	Mute control for left channel input PGA: 0=Input PGA not muted, normal operation 1=Input PGA muted (and disconnected from the following input BOOST stage).
	7	INPPGAZCL	0	Left channel input PGA zero cross enable: 0=Update gain when gain register changes 1=Update gain on 1 <sup>st</sup> zero cross after gain register write.
	8	INPPGAUPDATE	Not latched	INPPGAVOLL and INPPGAVOLR volume do not update until a 1 is written to INPPGAUPDATE (in reg 45 or 46)
R46 Right channel input PGA volume control	5:0	INPPGAVOLR	010000	Right channel input PGA volume 000000 = -12dB 000001 = -11.25db . 010000 = 0dB . 111111 = +35.25dB
	6	INPPGAMUTER	0	Mute control for right channel input PGA: 0=Input PGA not muted, normal operation 1=Input PGA muted (and disconnected from the following input BOOST stage).
	7	INPPGAZCR	0	Right channel input PGA zero cross enable: 0=Update gain when gain register changes 1=Update gain on 1 <sup>st</sup> zero cross after gain register write.
	8	INPPGAUPDATE	Not latched	INPPGAVOLL and INPPGAVOLR volume do not update until a 1 is written to INPPGAUPDATE (in reg 45 or 46)
R32 ALC control 1	8:7	ALCSEL	00	ALC function select: 00=ALC off 01=ALC right only 10=ALC left only 11=ALC both on

Table 8 Input PGA Volume Control

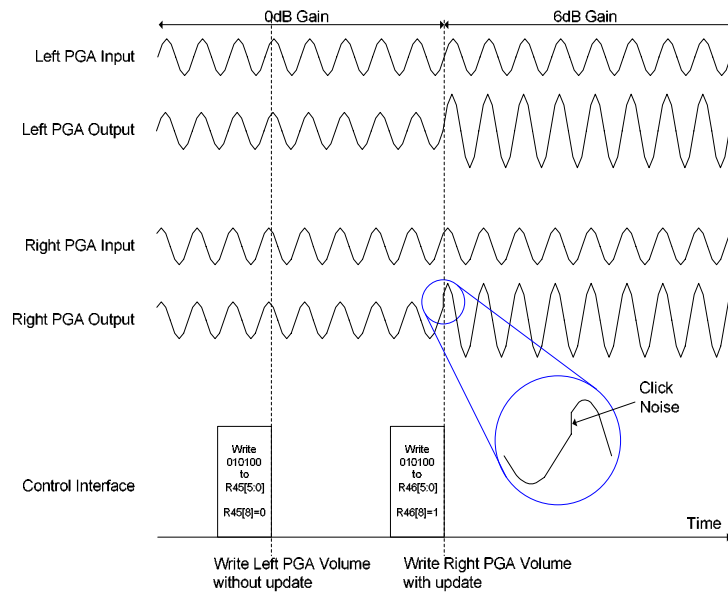
**VOLUME UPDATES**

Volume settings will not be applied to the PGAs until a '1' is written to one of the INPPGAUPDATE bits. This is to allow left and right channels to be updated at the same time, as shown in Figure 12.



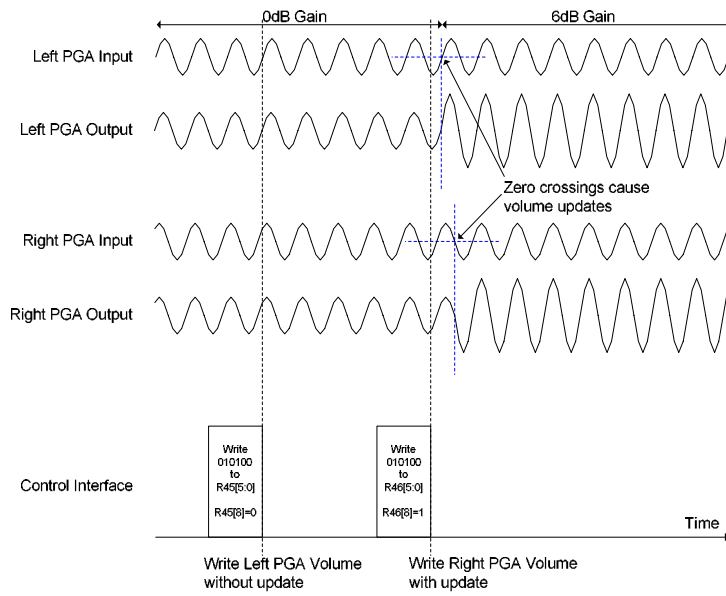
**Figure 12 Simultaneous Left and Right Volume Updates**

If the volume is adjusted while the signal is a non-zero value, an audible click can occur as shown in Figure 13.



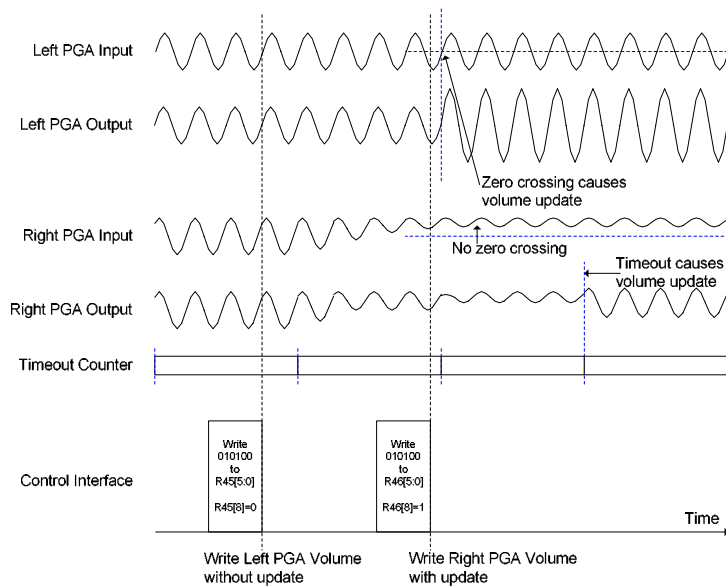
**Figure 13 Click Noise During Volume Update**

In order to prevent this click noise, a zero cross function is provided. When enabled, this will cause the PGA volume to update only when a zero crossing occurs, minimising click noise as shown in Figure 14.



**Figure 14 Volume Update Using Zero Cross Detection**

If there is a long period where no zero-crossing occurs, a timeout circuit in the WM8978 will automatically update the volume. The volume updates will occur between one and two timeout periods, depending on when the INPPGAUPDATE bit is set as shown in Figure 15.



**Figure 15 Volume Update after Timeout**

**AUXILIARY INPUTS**

There are two auxiliary inputs, AUXL and AUXR which can be used for a variety of purposes such as stereo line inputs or as a 'beep' input signal to be mixed with the outputs.

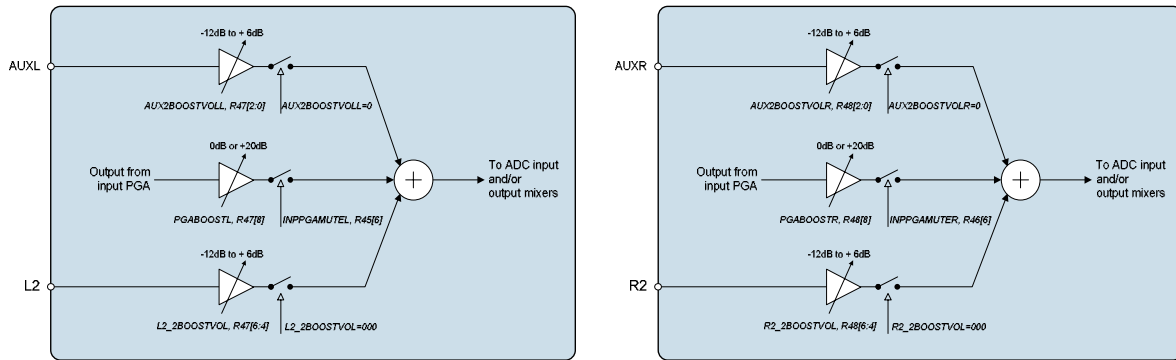
The AUXL/R inputs can be used as a line input to the input BOOST stage which has gain adjust of -12dB to +6dB in 3dB steps (plus off). See the INPUT BOOST section for further details.

The AUXL/R inputs can also be mixed into the output channel mixers, with a gain of -15dB to +6dB plus off.

In addition the AUXR input can be summed into the Right speaker output path (ROUT2) with a gain adjust of -15 to +6dB. This allows a 'beep' input to be output on the speaker outputs only without affecting the headphone or lineout signals.

**INPUT BOOST**

Each of the stereo input PGA stages is followed by an input BOOST circuit. The input BOOST circuit has 3 selectable inputs: the input microphone PGA output, the AUX amplifier output and the L2/R2 input pin (can be used as a line input, bypassing the input PGA). These three inputs can be mixed together and have individual gain boost/adjust as shown in Figure 16.



**Figure 16 Input Boost Stage**

The input PGA paths can have a +20dB boost (PGABOOSTL/R=1), a 0dB pass through (PGABOOSTL/R=0) or be completely isolated from the input boost circuit (INPPGAMUTEL/R=1).

REGISTER ADDRESS	BIT	LABEL	DEFAULT	DESCRIPTION
R47 Left Input BOOST control	8	PGABOOSTL	1	Boost enable for left channel input PGA: 0 = PGA output has +0dB gain through input BOOST stage. 1 = PGA output has +20dB gain through input BOOST stage.
R48 Right Input BOOST control	8	PGABOOSTR	1	Boost enable for right channel input PGA: 0 = PGA output has +0dB gain through input BOOST stage. 1 = PGA output has +20dB gain through input BOOST stage.

**Table 9 Input BOOST Stage Control**

The Auxilliary amplifier path to the BOOST stages is controlled by the AUXL2BOOSTVOL[2:0] and AUXR2BOOSTVOL[2:0] register bits. When AUXL2BOOSTVOL/AUXR2BOOSTVOL=000 this path is completely disconnected from the BOOST stage. Settings 001 through to 111 control the gain in 3dB steps from -12dB to +6dB.

The L2/R2 path to the BOOST stage is controlled by the LIP2BOOSTVOL[2:0] and the RIP2BOOSTVOL[2:0] register bits. When L2\_2BOOSTVOL/R2\_2BOOSTVOL=000 the L2/R2 input pin is completely disconnected from the BOOST stage. Settings 001 through to 111 control the gain in 3dB steps from -12dB to +6dB.



REGISTER ADDRESS	BIT	LABEL	DEFAULT	DESCRIPTION
R47 Left channel Input BOOST control	2:0	AUXL2BOOSTVOL	000	Controls the auxilliary amplifier to the left channel input boost stage: 000=Path disabled (disconnected) 001=-12dB gain through boost stage 010=-9dB gain through boost stage ... 111=+6dB gain through boost stage
	6:4	L2_2BOOSTVOL	000	Controls the L2 pin to the left channel input boost stage: 000=Path disabled (disconnected) 001=-12dB gain through boost stage 010=-9dB gain through boost stage ... 111=+6dB gain through boost stage
R48 Right channel Input BOOST control	2:0	AUXR2BOOSTVOL	000	Controls the auxilliary amplifier to the right channel input boost stage: 000=Path disabled (disconnected) 001=-12dB gain through boost stage 010=-9dB gain through boost stage ... 111=+6dB gain through boost stage
	6:4	R2_2BOOSTVOL	000	Controls the R2 pin to the right channel input boost stage: 000=Path disabled (disconnected) 001=-12dB gain through boost stage 010=-9dB gain through boost stage ... 111=+6dB gain through boost stage

Table 10 Input BOOST Stage Control

The BOOST stage is enabled under control of the BOOSTEN register bit.

REGISTER ADDRESS	BIT	LABEL	DEFAULT	DESCRIPTION
R2 Power management 2	4	BOOSTENL	0	Left channel Input BOOST enable 0 = Boost stage OFF 1 = Boost stage ON
	5	BOOSTENR	0	Right channel Input BOOST enable 0 = Boost stage OFF 1 = Boost stage ON

Table 11 Input BOOST Enable Control

### MICROPHONE BIASING CIRCUIT

The MICBIAS output provides a low noise reference voltage suitable for biasing electret type microphones and the associated external resistor biasing network. Refer to the Applications Information section for recommended external components. The MICBIAS voltage can be altered via the MBVSEL register bit. When MBVSEL=0, MICBIAS=0.9\*AVDD and when MBVSEL=1, MICBIAS=0.65\*AVDD. The output can be enabled or disabled using the MICBEN control bit.

REGISTER ADDRESS	BIT	LABEL	DEFAULT	DESCRIPTION
R1 Power management 1	4	MICBEN	0	Microphone Bias Enable 0 = OFF (high impedance output) 1 = ON

Table 12 Microphone Bias Enable Control

REGISTER ADDRESS	BIT	LABEL	DEFAULT	DESCRIPTION
R44 Input control	8	MBVSEL	0	Microphone Bias Voltage Control 0 = 0.9 * AVDD 1 = 0.65 * AVDD

Table 13 Microphone Bias Voltage Control

The internal MICBIAS circuitry is shown in **Figure 17**. Note that the maximum source current capability for MICBIAS is 3mA. The external biasing resistors therefore must be large enough to limit the MICBIAS current to 3mA.

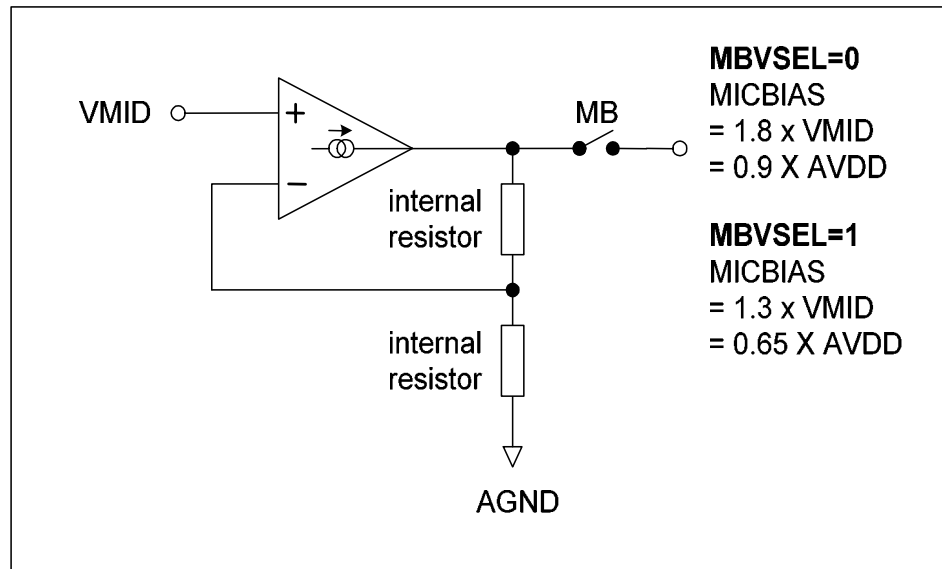


Figure 17 Microphone Bias Schematic

### ANALOGUE TO DIGITAL CONVERTER (ADC)

The WM8978 uses stereo multi-bit, oversampled sigma-delta ADCs. The use of multi-bit feedback and high oversampling rates reduces the effects of jitter and high frequency noise. The ADC Full Scale input level is proportional to AVDD. With a 3.3V supply voltage, the full scale level is 1.0V<sub>rms</sub>. Any voltage greater than full scale may overload the ADC and cause distortion.

### ADC DIGITAL FILTERS

The ADC filters perform true 24 bit signal processing to convert the raw multi-bit oversampled data from the ADC to the correct sampling frequency to be output on the digital audio interface. The digital filter path for each ADC channel is illustrated in Figure 18.

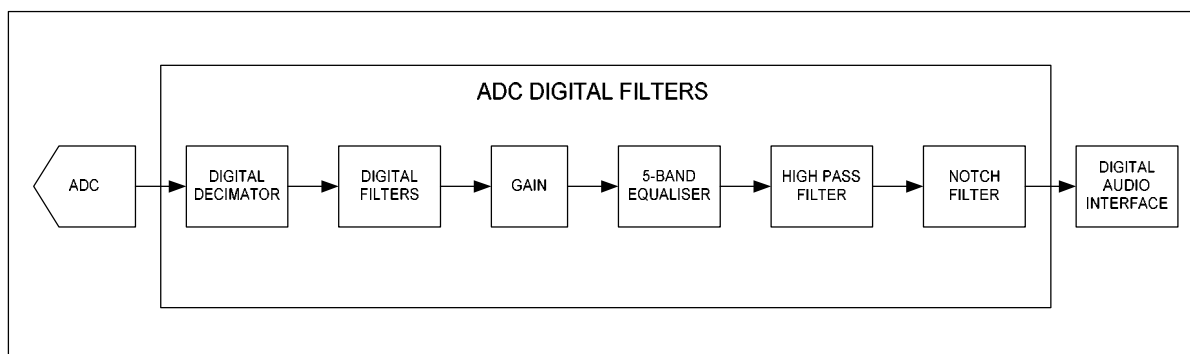


Figure 18 ADC Digital Filter Path

The ADCs are enabled by the ADCENL/R register bit.

REGISTER ADDRESS	BIT	LABEL	DEFAULT	DESCRIPTION
R2 Power management 2	0	ADCENL	0	Enable ADC left channel: 0 = ADC disabled 1 = ADC enabled
	1	ADCENR	0	Enable ADC right channel: 0 = ADC disabled 1 = ADC enabled

Table 14 ADC Enable Control

The polarity of the output signal can also be changed under software control using the ADCLPOL/ADCRPOL register bit. The oversampling rate of the ADC can be adjusted using the ADCOSR register bit. With ADCOSR=0 the oversample rate is 64x which gives lowest power operation and when ADCOSR=1 the oversample rate is 128x which gives best performance.

REGISTER ADDRESS	BIT	LABEL	DEFAULT	DESCRIPTION
R14 ADC Control	0	ADCLPOL	0	ADC left channel polarity adjust: 0=normal 1=inverted
	1	ADCRPOL	0	ADC right channel polarity adjust: 0=normal 1=inverted
	3	ADCOSR	0	ADC oversample rate select: 0=64x (lower power) 1=128x (best performance)

Table 15 ADC Control

### SELECTABLE HIGH PASS FILTER

A selectable high pass filter is provided. To disable this filter set HPFEN=0. The filter has two modes controlled by HPFAPP. In Audio Mode (HPFAPP=0) the filter is first order, with a cut-off frequency of 3.7Hz. In Application Mode (HPFAPP=1) the filter is second order, with a cut-off frequency selectable via the HPFCUT register. The cut-off frequencies when HPFAPP=1 are shown in Table 17.

REGISTER ADDRESS	BIT	LABEL	DEFAULT	DESCRIPTION
R14 ADC Control	8	HPFEN	1	High Pass Filter Enable 0=disabled 1=enabled
	7	HPFAPP	0	Select audio mode or application mode 0=Audio mode (1 <sup>st</sup> order, $f_c = \sim 3.7\text{Hz}$ ) 1=Application mode (2 <sup>nd</sup> order, $f_c = \text{HPFCUT}$ )
	6:4	HPFCUT	000	Application mode cut-off frequency See Table 17 for details.

Table 16 ADC Enable Control

HPFCUT [2:0]	SR=101/100			SR=011/010			SR=001/000		
	fs (kHz)								
	8	11.025	12	16	22.05	24	32	44.1	48
000	82	113	122	82	113	122	82	113	122
001	102	141	153	102	141	153	102	141	153
010	131	180	156	131	180	156	131	180	156
011	163	225	245	163	225	245	163	225	245
100	204	281	306	204	281	306	204	281	306
101	261	360	392	261	360	392	261	360	392
110	327	450	490	327	450	490	327	450	490
111	408	563	612	408	563	612	408	563	612

Table 17 High Pass Filter Cut-off Frequencies (HPFAPP=1). Values in Hz.

Note that the High Pass filter values (when HPFAPP=1) are calculated with the assumption that the SR register bits are set correctly for the actual sample rate as shown in Table 17.

**PROGRAMMABLE NOTCH FILTER**

A programmable notch filter is provided. This filter has a variable centre frequency and bandwidth, programmable via two coefficients, a0 and a1. a0 and a1 are represented by the register bits NFA0[13:0] and NFA1[13:0]. Because these coefficient values require four register writes to setup there is an NFU (Notch Filter Update) flag which should be set only when all four registers are setup.

REGISTER ADDRESS	BIT	LABEL	DEFAULT	DESCRIPTION
R27 Notch Filter 1	6:0	NFA0[13:7]	0	Notch Filter a0 coefficient, bits [13:7]
	7	NFEN	0	Notch filter enable: 0=Disabled 1=Enabled
	8	NFU	0	Notch filter update. The notch filter values used internally only update when one of the NFU bits is set high.
R28 Notch Filter 2	6:0	NFA0[6:0]	0	Notch Filter a0 coefficient, bits [6:0]
	8	NFU	0	Notch filter update. The notch filter values used internally only update when one of the NFU bits is set high.
R29 Notch Filter 3	6:0	NFA1[13:7]	0	Notch Filter a1 coefficient, bits [13:7]
	8	NFU	0	Notch filter update. The notch filter values used internally only update when one of the NFU bits is set high.
R30 Notch Filter 4	0-6	NFA1[6:0]	0	Notch Filter a1 coefficient, bits [6:0]
	8	NFU	0	Notch filter update. The notch filter values used internally only update when one of the NFU bits is set high.

**Table 18 Notch Filter Function**

The coefficients are calculated as follows:

$$a_0 = \frac{1 - \tan(w_b / 2)}{1 + \tan(w_b / 2)}$$

$$a_1 = -(1 + a_0) \cos(w_0)$$

Where:

$$w_0 = 2\pi f_c / f_s$$

$$w_b = 2\pi f_b / f_s$$

$f_c$  = centre frequency in Hz,  $f_b$  = -3dB bandwidth in Hz,  $f_s$  = sample frequency in Hz

The actual register values can be determined from the coefficients as follows:

$$\text{NFA0} = -a_0 \times 2^{13}$$

$$\text{NFA1} = -a_1 \times 2^{12}$$

**NOTCH FILTER WORKED EXAMPLE**

The following example illustrates how to calculate the a0 and a1 coefficients for a desired centre frequency and -3dB bandwidth.

$$f_c = 1000 \text{ Hz}$$

$$f_b = 100 \text{ Hz}$$

$$f_s = 48000 \text{ Hz}$$

$$w_0 = 2\pi f_c / f_s = 2\pi \times (1000 / 48000) = 0.1308996939 \text{ rads}$$

$$w_b = 2\pi f_b / f_s = 2\pi \times (100 / 48000) = 0.01308996939 \text{ rads}$$

$$a_0 = \frac{1 - \tan(w_b / 2)}{1 + \tan(w_b / 2)} = \frac{1 - \tan(0.01308996939 / 2)}{1 + \tan(0.01308996939 / 2)} = 0.9869949627$$

$$a_1 = -(1 + a_0) \cos(w_0) = -(1 + 0.9869949627) \cos(0.1308996939) = -1.969995945$$

$$\text{NFA0} = -a_0 \times 213 = -8085 \text{ (rounded to nearest whole number)}$$

$$\text{NFA1} = -a_1 \times 212 = 8069 \text{ (rounded to nearest whole number)}$$

These values are then converted to a 14-bit sign / magnitude notation:

$$\text{NFA0}[13] = 1; \text{NFA0}[12:0] = 13'h1F95; \text{NFA0} = 14'h3F95 = 14'b111111110010101$$

$$\text{NFA1}[13] = 0; \text{NFA1}[12:0] = 13'h1F85; \text{NFA1} = 14'h1F85 = 14'b011111110000101$$

**DIGITAL ADC VOLUME CONTROL**

The output of the ADCs can be digitally attenuated over a range from -127dB to 0dB in 0.5dB steps. The gain for a given eight-bit code X is given by:

$$0.5 \times (G-255) \text{ dB for } 1 \leq G \leq 255; \quad \text{MUTE for } G = 0$$

REGISTER ADDRESS	BIT	LABEL	DEFAULT	DESCRIPTION
R15 Left channel ADC Digital Volume	7:0	ADCVOLL [7:0]	11111111 ( 0dB )	Left ADC Digital Volume Control 0000 0000 = Digital Mute 0000 0001 = -127dB 0000 0010 = -126.5dB ... 0.5dB steps up to 1111 1111 = 0dB
	8	ADCVU	Not latched	ADC left and ADC right volume do not update until a 1 is written to ADCVU (in reg 15 or 16)

R16 Right channel ADC Digital Volume	7:0	ADCVOLR [7:0]	11111111 ( 0dB )	Right ADC Digital Volume Control 0000 0000 = Digital Mute 0000 0001 = -127dB 0000 0010 = -126.5dB ... 0.5dB steps up to 1111 1111 = 0dB
	8	ADCVU	Not latched	ADC left and ADC right volume do not update until a 1 is written to ADCVU (in reg 15 or 16)

Table 19 ADC Digital Volume Control

**INPUT LIMITER / AUTOMATIC LEVEL CONTROL (ALC)**

The WM8978 has an automatic PGA gain control circuit, which can function as an input peak limiter or as an automatic level control (ALC).

The Automatic Level Control (ALC) provides continuous adjustment of the input PGA in response to the amplitude of the input signal. A digital peak detector monitors the input signal amplitude and compares it to a register defined threshold level (ALCLVL).

If the signal is below the threshold, the ALC will increase the gain of the PGA at a rate set by ALDCDY. If the signal is above the threshold, the ALC will reduce the gain of the PGA at a rate set by ALCATK.

The ALC has two modes selected by the ALCMODE register: normal mode and peak limiter mode. The ALC/limiter function is enabled by setting the register bit R32[8] ALCSEL.

REGISTER ADDRESS	BIT	LABEL	DEFAULT	DESCRIPTION
R32 (20h) ALC Control 1	2:0	ALCMIN [2:0]	000 (-12dB)	Set minimum gain of PGA 000 = -12dB 001 = -6dB 010 = 0dB 011 = +6dB 100 = +12dB 101 = +18dB 110 = +24dB 111 = +30dB
	5:3	ALCMAX [2:0]	111 (+35.25dB)	Set Maximum Gain of PGA 111 = +35.25dB 110 = +29.25dB 101 = +23.25dB 100 = +17.25dB 011 = +11.25dB 010 = +5.25dB 001 = -0.75dB 000 = -6.75dB
	8:7	ALCSEL	00	ALC function select 00 = ALC disabled 01 = Right channel ALC enabled 10 = Left channel ALC enabled 11 = Both channels ALC enabled
R33 (21h) ALC Control 2	3:0	ALCLVL [3:0]	1011 (-6dB)	ALC target – sets signal level at ADC input 1111 = -1.5dBFS 1110 = -1.5dBFS 1101 = -3dBFS 1100 = -4.5dBFS 1011 = -6dBFS 1010 = -7.5dBFS 1001 = -9dBFS 1000 = -10.5dBFS 0111 = -12dBFS 0110 = -13.5dBFS 0101 = -15dBFS 0100 = -16.5dBFS 0011 = -18dBFS 0010 = -19.5dBFS 0001 = -21dBFS 0000 = -22.5dBFS



REGISTER ADDRESS	BIT	LABEL	DEFAULT	DESCRIPTION			
	8	ALCZC	0 (zero cross off)	ALC uses zero cross detection circuit. 0 = Disabled (recommended) 1 = Enabled			
	7:4	ALCHLD [3:0]	0000 (0ms)	ALC hold time before gain is increased. 0000 = 0ms 0001 = 2.67ms 0010 = 5.33ms 0011 = 10.66ms 0100 = 21.32ms 0101 = 42.64ms 0110 = 85.28ms 0111 = 0.17s 1000 = 0.34s 1001 = 0.68s 1010 or higher = 1.36s			
R34 (22h) ALC Control 3	8	ALCMODE	0	Determines the ALC mode of operation: 0 = ALC mode (Normal Operation) 1 = Limiter mode.			
	7:4	ALCDCY [3:0]	0011 (26ms/6dB)	Decay (gain ramp-up) time (ALCMODE ==0)			
					Per step	Per 6dB	90% of range
				0000	410us	3.38ms	23.6ms
				0001	820us	6.56ms	47.2ms
				0010	1.64ms	13.1ms	94.5ms
				... (time doubles with every step)			
				1010 or higher	420ms	3.36s	24.2s
				0011 (5.8ms/6dB)	Decay (gain ramp-up) time (ALCMODE ==1)		
					Per step	Per 6dB	90% of range
0000				90.8us	726us	5.23ms	
0001	182us	1.45ms	10.5ms				
0010	363us	2.91ms	20.9ms				
... (time doubles with every step)							
1010	93ms	744ms	5.36s				
3:0	ALCATK [3:0]	0010 (3.3ms/6dB)	ALC attack (gain ramp-down) time (ALCMODE == 0)				
				Per step	Per 6dB	90% of range	
			0000	104us	832us	6ms	
			0001	208us	1.66ms	12ms	
			0010	416us	3.33ms	24ms	
			... (time doubles with every step)				
			1010 or higher	106ms	852ms	6.13s	
			0010 (726us/6dB)	ALC attack (gain ramp-down) time (ALCMODE == 1)			
				Per step	Per 6dB	90% of range	

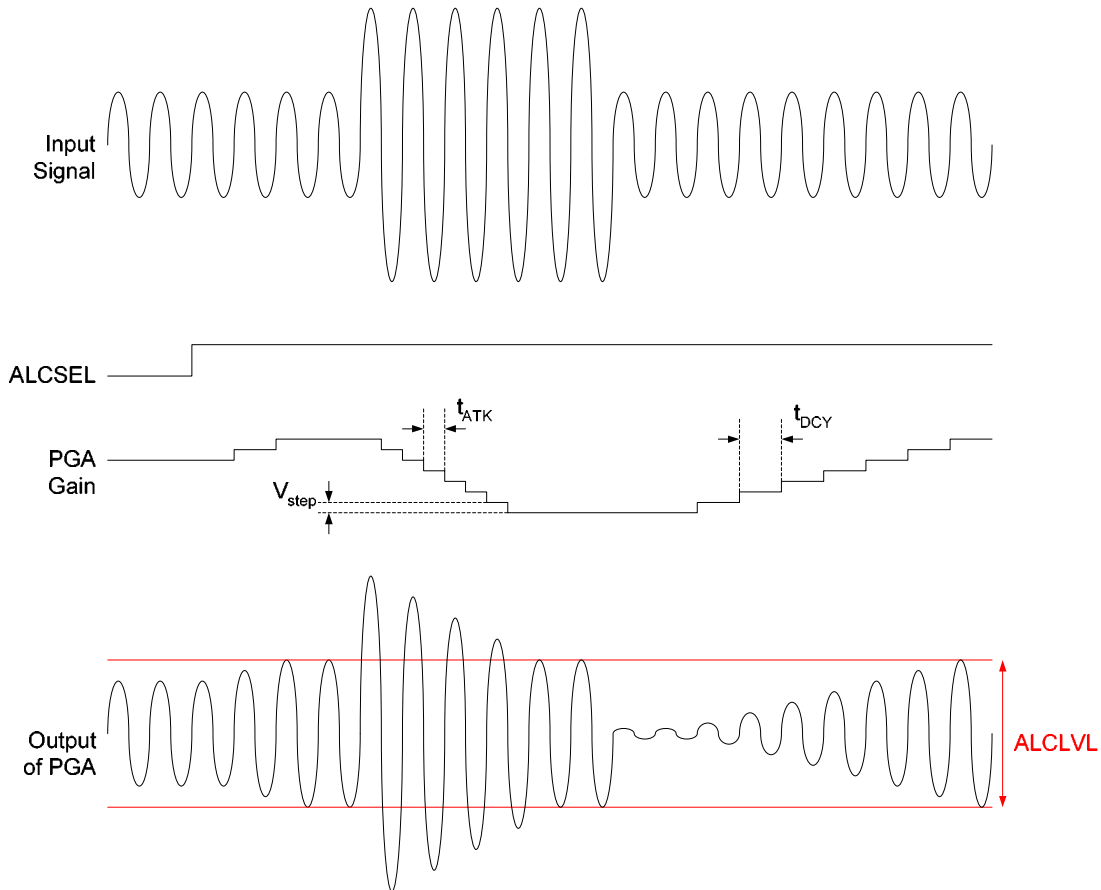
REGISTER ADDRESS	BIT	LABEL	DEFAULT	DESCRIPTION			
				0000	22.7us	182.4us	1.31ms
				0001	45.4us	363us	2.62ms
				0010	90.8us	726us	5.23ms
				... (time doubles with every step)			
				1010 or higher	23.2ms	186ms	1.34s

**Table 20 ALC Control Registers**

When the ALC is disabled, the input PGA remains at the last controlled value of the ALC. An input gain update must be made by writing to the INPPGAVOLL/R register bits.

**NORMAL MODE**

In normal mode, the ALC will attempt to maintain a constant signal level by increasing or decreasing the gain of the PGA. The following diagram shows an example of this.



**Figure 19 ALC Normal Mode Operation**

## LIMITER MODE

In limiter mode, the ALC will reduce peaks that go above the threshold level, but will not increase the PGA gain beyond the starting level. The starting level is the PGA gain setting when the ALC is enabled in limiter mode. If the ALC is started in limiter mode, this is the gain setting of the PGA at start-up. If the ALC is switched into limiter mode after running in ALC mode, the starting gain will be the gain at switchover. The diagram below shows an example of limiter mode.

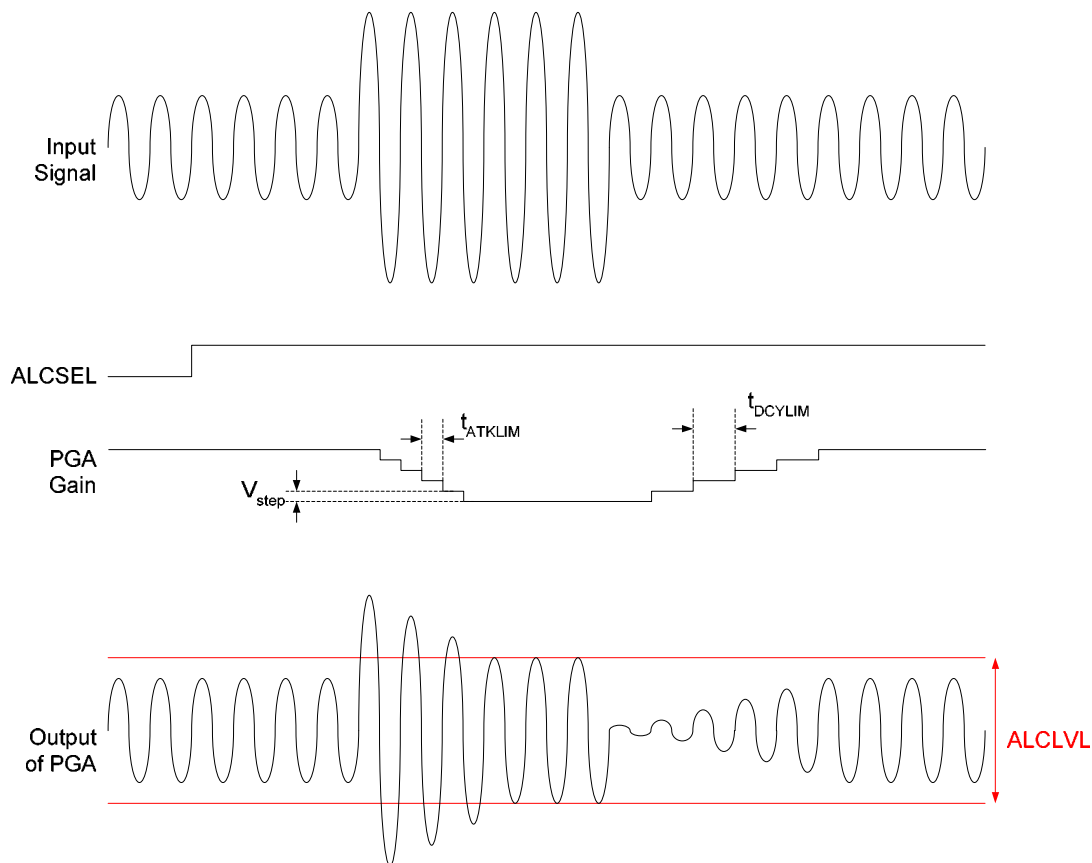


Figure 20 ALC Limiter Mode Operation

### ATTACK AND DECAY TIMES

The attack and decay times set the update times for the PGA gain. The attack time is the time constant used when the gain is reducing. The decay time is the time constant used when the gain is increasing. In limiter mode, the time constants are faster than in ALC mode. The time constants are shown below in terms of a single gain step, a change of 6dB and a change of 90% of the PGAs gain range.

Note that, these times will vary slightly depending on the sample rate used (specified by the SR register).

## NORMAL MODE

ALCMODE = 0 (Normal Mode)			
Attack Time (s)			
ALCATK	t <sub>ATK</sub>	t <sub>ATK6dB</sub>	t <sub>ATK90%</sub>
0000	104µs	832µs	6ms
0001	208µs	1.66ms	12ms
0010	416µs	3.33ms	24ms
0011	832µs	6.66ms	48ms
0100	1.66ms	13.3ms	96ms
0101	3.33ms	26.6ms	192ms
0110	6.66ms	53.2ms	384ms
0111	13.3ms	106ms	767ms
1000	26.6ms	213.2ms	1.53s
1001	53.2ms	426ms	3.07s
1010	106ms	852ms	6.13s

ALCMODE = 0 (Normal Mode)			
Decay Time (s)			
ALCDCY	t <sub>DCY</sub>	t <sub>DCY6dB</sub>	t <sub>DCY90%</sub>
0000	410µs	3.28ms	23.6ms
0001	820µs	6.56ms	47.2ms
0010	1.64ms	13.1ms	94.5ms
0011	3.28ms	26.2ms	189ms
0100	6.56ms	52.5ms	378ms
0101	13.1ms	105ms	756ms
0110	26.2ms	210ms	1.51s
0111	52.5ms	420ms	3.02s
1000	105ms	840ms	6.05s
1001	210ms	1.68s	12.1s
1010	420ms	3.36s	24.2s

Table 21 ALC Normal Mode (Attack and Decay times)

**LIMITER MODE**

ALCMODE = 1 (Limiter Mode)			
	Attack Time (s)		
ALCATK	t <sub>ATKLIM</sub>	t <sub>ATKLIM6dB</sub>	t <sub>ATKLIM90%</sub>
0000	22.7µs	182µs	1.31ms
0001	45.4µs	363µs	2.62ms
0010	90.8µs	726µs	5.23ms
0011	182µs	1.45ms	10.5ms
0100	363µs	2.91ms	20.9ms
0101	726µs	5.81ms	41.8ms
0110	1.45ms	11.6ms	83.7ms
0111	2.9ms	23.2ms	167ms
1000	5.81ms	46.5ms	335ms
1001	11.6ms	93ms	669ms
1010	23.2ms	186ms	1.34s

ALCMODE = 1 (Limiter Mode)			
	Attack Time (s)		
ALCDCY	t <sub>DCYLIM</sub>	t <sub>DCYLIM6dB</sub>	t <sub>DCYLIM90%</sub>
0000	90.8µs	726µs	5.23ms
0001	182µs	1.45ms	10.5ms
0010	363µs	2.91ms	20.9ms
0011	726µs	5.81ms	41.8ms
0100	1.45ms	11.6ms	83.7ms
0101	2.91ms	23.2ms	167ms
0110	5.81ms	46.5ms	335ms
0111	11.6ms	93ms	669ms
1000	23.2ms	186ms	1.34s
1001	46.5ms	372ms	2.68s
1010	93ms	744ms	5.36s

Table 22 ALC Limiter Mode (Attack and Decay times)

**MINIMUM AND MAXIMUM GAIN**

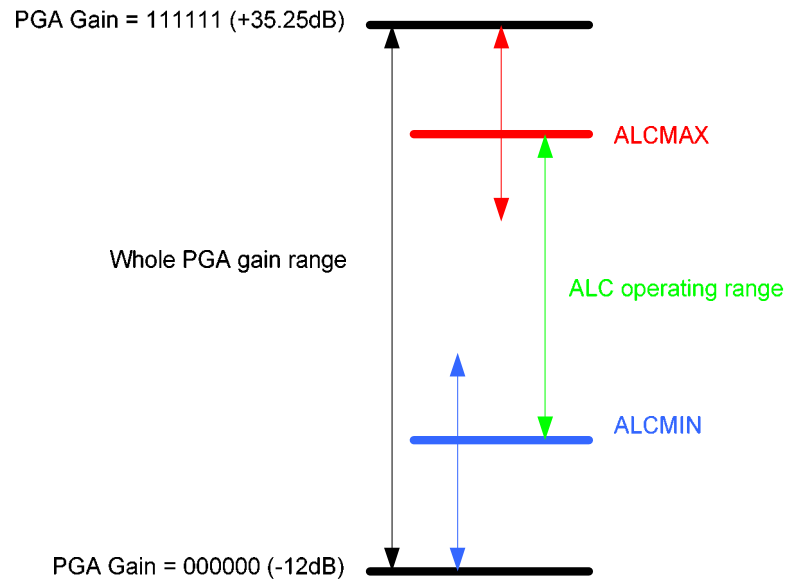
The ALCMIN and ALCMAX register bits set the minimum/maximum gain value that the PGA can be set to whilst under the control of the ALC. This has no effect on the PGA when ALC is not enabled.

REGISTER ADDRESS	BIT	LABEL	DEFAULT	DESCRIPTION
R32	5:3	ALCMAX	111	Set Maximum Gain of PGA
ALC Control 1	2:0	ALCMIN	000	Set minimum gain of PGA

**Table 23 ALC Max/Min Gain**

In normal mode, ALCMAX sets the maximum boost which can be applied to the signal. In limiter mode, ALCMAX will normally have no effect (assuming the starting gain value is less than the maximum gain specified by ALCMAX) because the maximum gain is set at the starting gain level.

ALCMIN sets the minimum gain value which can be applied to the signal.



**Figure 21 ALC Min/Max Gain**

ALCMAX	Maximum Gain (dB)
111	35.25
110	29.25
101	23.25
100	17.25
011	11.25
010	5.25
001	-0.75
000	-6.75

**Table 24 ALC Max Gain Values**

ALCMIN	Minimum Gain (dB)
000	-12
001	-6
010	0
011	6
100	12
101	18
110	24
111	30

**Table 25 ALC Min Gain Values**

Note that if the ALC gain setting strays outside the ALC operating range, either by starting the ALC outside of the range or changing the ALCMAX or ALCMIN settings during operation, the ALC will immediately adjust the gain to return to the ALC operating range. It is recommended that the ALC starting gain is set between the ALCMAX and ALCMIN limits.

**ALC HOLD TIME (NORMAL MODE ONLY)**

In Normal mode, the ALC has an adjustable hold time which sets a time delay before the ALC begins its decay phase (gain increasing). The hold time is set by the ALCHLD register.

REGISTER ADDRESS	BIT	LABEL	DEFAULT	DESCRIPTION
R33 ALC Control 2	7:4	ALCHLD	0000	ALC hold time before gain is increased.

**Table 26 ALC Hold Time**

If the hold time is exceeded this indicates that the signal has reached a new average level and the ALC will increase the gain to adjust for that new average level. If the signal goes above the threshold during the hold period, the hold phase is abandoned and the ALC returns to normal operation.

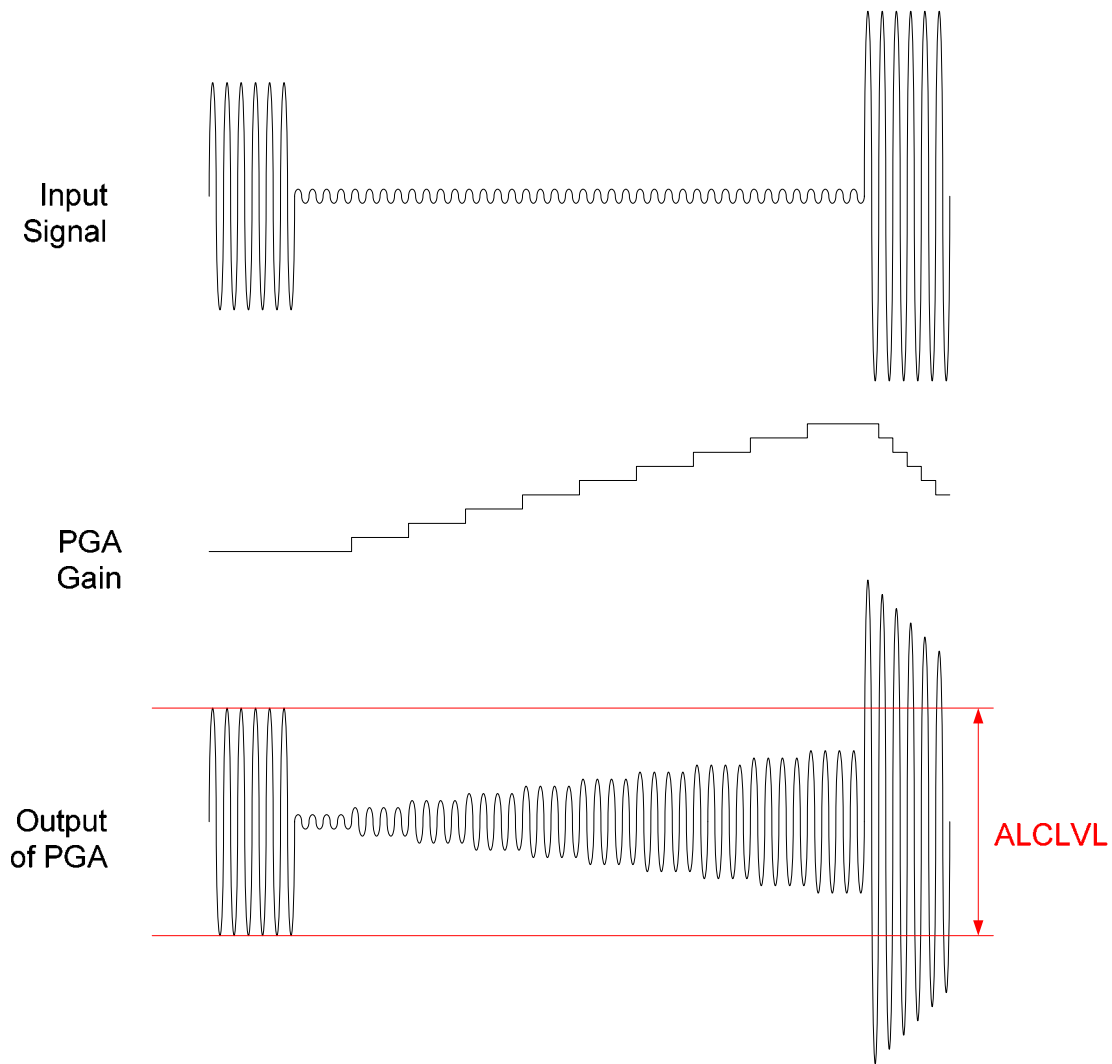


Figure 22 ALCLVL



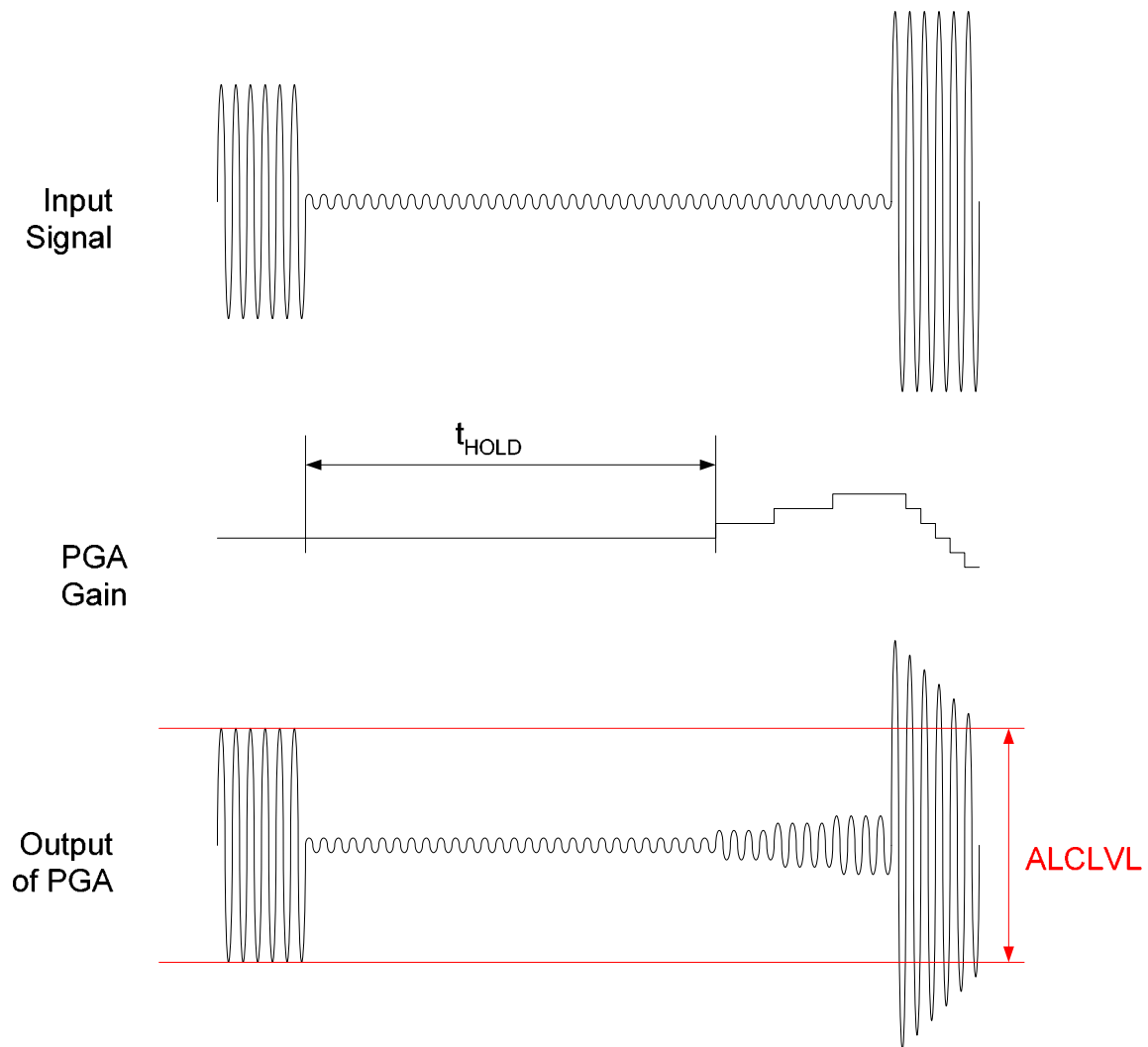


Figure 23 ALC Hold Time

ALCHLD	$t_{\text{HOLD}}$ (s)
0000	0
0001	2.67ms
0010	5.34ms
0011	10.7ms
0100	21.4ms
0101	42.7ms
0110	85.4ms
0111	171ms
1000	342ms
1001	684ms
1010	1.37s

Table 27 ALC Hold Time Values

## PEAK LIMITER

To prevent clipping when a large signal occurs just after a period of quiet, the ALC circuit includes a limiter function. If the ADC input signal exceeds 87.5% of full scale (-1.16dB), the PGA gain is ramped down at the maximum attack rate (as when ALCATK = 0000), until the signal level falls below 87.5% of full scale. This function is automatically enabled whenever the ALC is enabled.

**Note:** If ALCATK = 0000, then the limiter makes no difference to the operation of the ALC. It is designed to prevent clipping when long attack times are used.

## NOISE GATE (NORMAL MODE ONLY)

When the signal is very quiet and consists mainly of noise, the ALC function may cause “noise pumping”, i.e. loud hissing noise during silence periods. The WM8978 has a noise gate function that prevents noise pumping by comparing the signal level at the input pins against a noise gate threshold, NGTH. The noise gate cuts in when:

$$\text{Signal level at ADC [dBFS]} < \text{NGTH [dBFS]} + \text{PGA gain [dB]} + \text{Mic Boost gain [dB]}$$

This is equivalent to:

$$\text{Signal level at input pin [dBFS]} < \text{NGTH [dBFS]}$$

The PGA gain is then held constant (preventing it from ramping up as it normally would when the signal is quiet).

The table below summarises the noise gate control register. The NGTH control bits set the noise gate threshold with respect to the ADC full-scale range. The threshold is adjusted in 6dB steps. Levels at the extremes of the range may cause inappropriate operation, so care should be taken with set-up of the function. The noise gate only operates in conjunction with the ALC and cannot be used in limiter mode.

REGISTER ADDRESS	BIT	LABEL	DEFAULT	DESCRIPTION
R35 (23h) ALC Noise Gate Control	2:0	NGTH	000	Noise gate threshold: 000 = -39dB 001 = -45dB 010 = -51db 011 = -57dB 100 = -63dB 101 = -69dB 110 = -75dB 111 = -81dB
	3	NGATEN	0	Noise gate function enable 1 = enable 0 = disable

**Table 28 ALC Noise Gate Control**

The diagrams below show the response of the system to the same signal with and without noise gate.

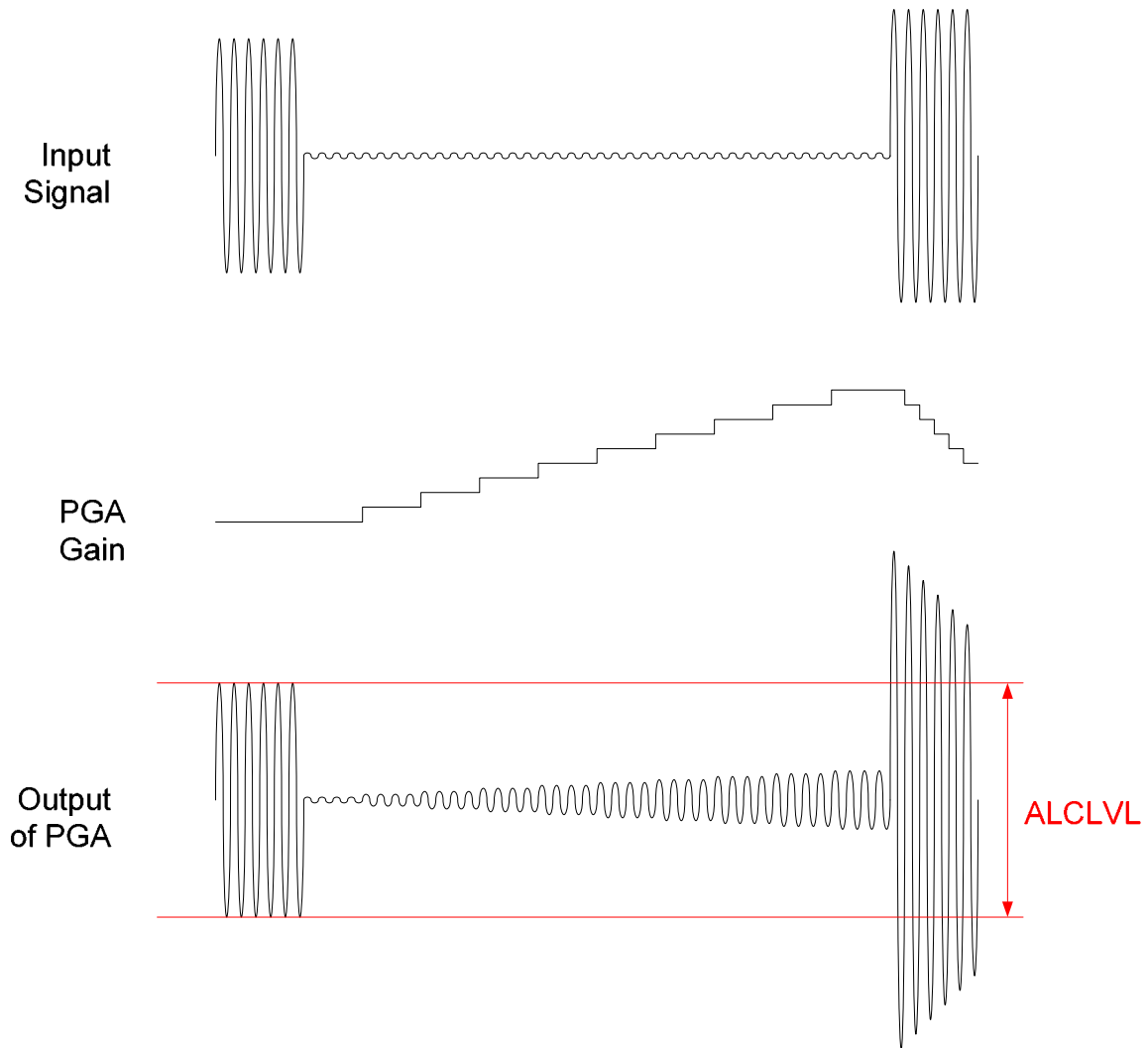


Figure 24 ALC Operation Above Noise Gate Threshold

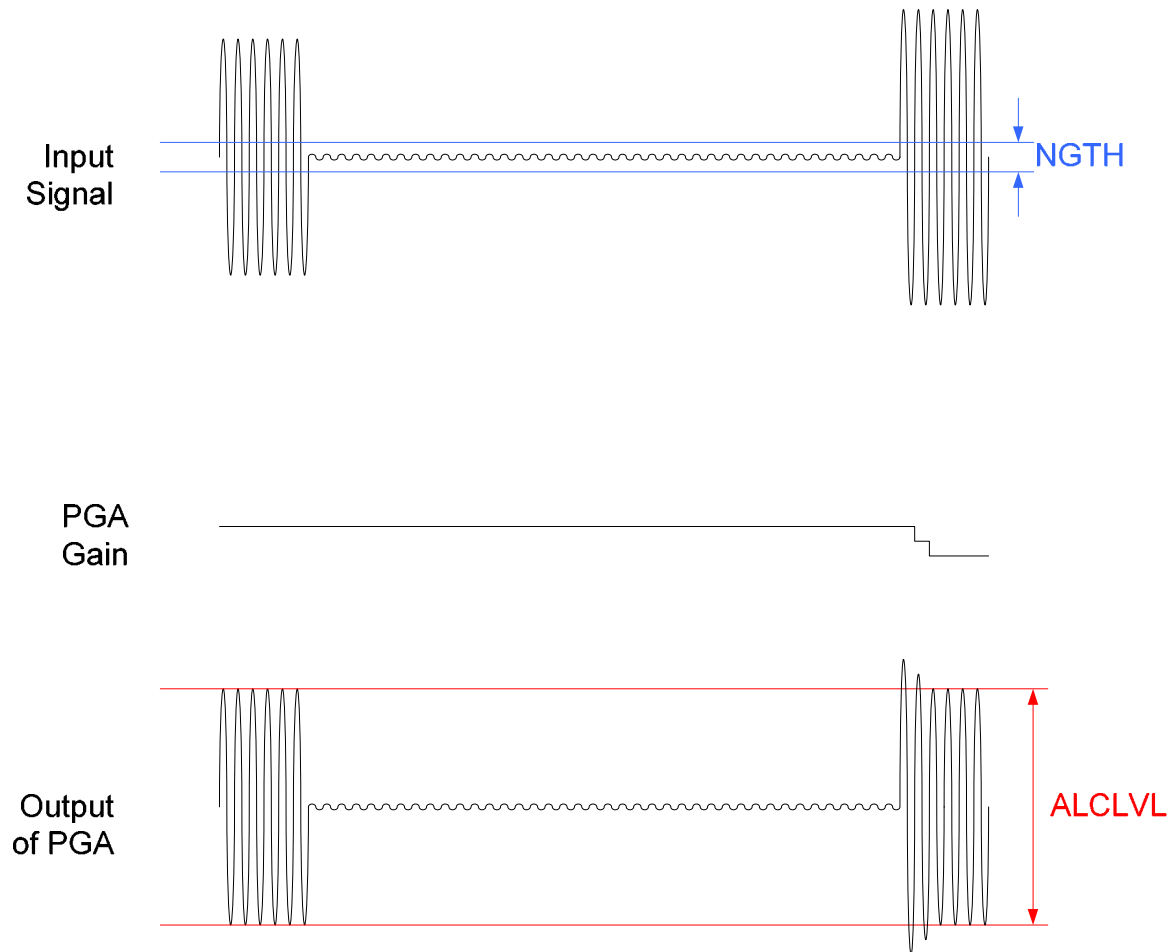


Figure 25 Noise Gate Operation

## OUTPUT SIGNAL PATH

The WM8978 output signal paths consist of digital application filters, up-sampling filters, stereo Hi-Fi DACs, analogue mixers, speaker, stereo headphone and stereo line/mono/midrail output drivers. The digital filters and DAC are enabled by register bits DACENL and DACENR. The mixers and output drivers can be separately enabled by individual control bits (see Analogue Outputs). Thus it is possible to utilise the analogue mixing and amplification provided by the WM8978, irrespective of whether the DACs are enabled or not.

The WM8978 DACs receive digital input data on the DACDAT pin. The digital filter block processes the data to provide the following functions:

- § Digital volume control
- § Graphic equaliser
- § Digital peak limiter.
- § Sigma-Delta Modulation

High performance sigma-delta 24-bit audio DAC converts the digital data into an analogue signal.

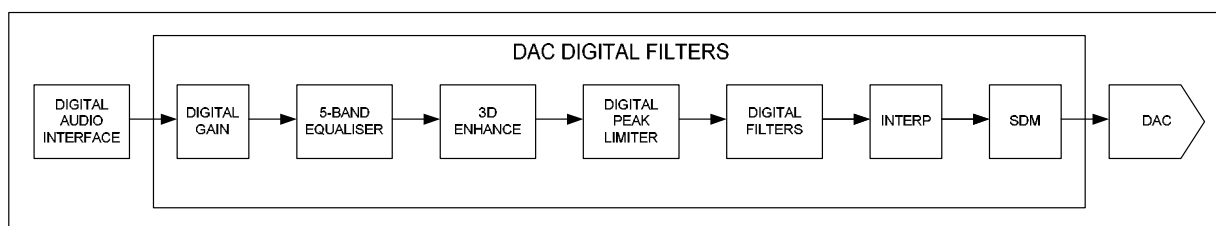


Figure 26 DAC Digital Filter Path

The analogue outputs from the DACs can then be mixed with the aux analogue inputs and the ADC analogue inputs. The mix is fed to the output drivers for headphone (LOUT1/ROUT1), speaker (LOUT2/ROUT2) or line (OUT3/OUT4). OUT3 and OUT4 have additional mixers which allow them to output different signals to the headphone and speaker outputs.

### DIGITAL PLAYBACK (DAC) PATH

Digital data is passed to the WM8978 via the flexible audio interface and is then passed through a variety of advanced digital filters (as shown in Figure 26) to the hi-fi DACs. The DACs are enabled by the DACENL/R register bits.

REGISTER ADDRESS	BIT	LABEL	DEFAULT	DESCRIPTION
R3 Power Management 3	0	DACENL	0	Left channel DAC enable 0 = DAC disabled 1 = DAC enabled
	1	DACENR	0	Right channel DAC enable 0 = DAC disabled 1 = DAC enabled

Table 29 DAC Enable Control

The WM8978 also has a Soft Mute function, which, when enabled, gradually attenuates the volume of the digital signal to zero. When disabled, the gain will ramp back up to the digital gain setting. This function is enabled by default. To play back an audio signal, this function must first be disabled by setting the SOFTMUTE bit to zero.

REGISTER ADDRESS	BIT	LABEL	DEFAULT	DESCRIPTION
R10 DAC Control	0	DACPOLL	0	Left DAC output polarity: 0 = non-inverted 1 = inverted (180 degrees phase shift)
	1	DACPOLR	0	Right DAC output polarity: 0 = non-inverted 1 = inverted (180 degrees phase shift)
	2	AMUTE	0	Automute enable 0 = Amute disabled 1 = Amute enabled
	3	DACOSR	0	DAC oversampling rate: 0=64x (lowest power) 1=128x (best performance)
	6	SOFTMUTE	0	Softmute enable: 0=Enabled 1=Disabled

Table 30 DAC Control Register

The digital audio data is converted to oversampled bit streams in the on-chip, true 24-bit digital interpolation filters. The bitstream data enters the multi-bit, sigma-delta DACs, which convert it to a high quality analogue audio signal. The multi-bit DAC architecture reduces high frequency noise and sensitivity to clock jitter. It also uses a Dynamic Element Matching technique for high linearity and low distortion.

The DAC output phase defaults to non-inverted. Setting DACPOLL will invert the DAC output phase on the left channel and DACPOLR inverts the phase on the right channel.

### AUTO-MUTE

The DAC has an auto-mute function which applies an analogue mute when 1024 consecutive zeros are detected. The mute is released as soon as a non-zero sample is detected. Automute can be disabled using the AMUTE control bit.

### DIGITAL HI-FI DAC VOLUME (GAIN) CONTROL

The signal volume from each Hi-Fi DAC can be controlled digitally. The gain and attenuation range is -127dB to 0dB in 0.5dB steps. The level of attenuation for an eight-bit code X is given by:

$$0.5 \times (X-255) \text{ dB for } 1 \leq X \leq 255; \quad \text{MUTE for } X = 0$$

REGISTER ADDRESS	BIT	LABEL	DEFAULT	DESCRIPTION
R11 Left DAC Digital Volume	7:0	DACVOLL [7:0]	11111111 ( 0dB )	Left DAC Digital Volume Control 0000 0000 = Digital Mute 0000 0001 = -127dB 0000 0010 = -126.5dB ... 0.5dB steps up to 1111 1111 = 0dB
	8	DACVU	Not latched	DAC left and DAC right volume do not update until a 1 is written to DACVU (in reg 11 or 12)
R12 Right DAC Digital Volume	7:0	DACVOLR [7:0]	11111111 ( 0dB )	Right DAC Digital Volume Control 0000 0000 = Digital Mute 0000 0001 = -127dB 0000 0010 = -126.5dB ... 0.5dB steps up to 1111 1111 = 0dB
	8	DACVU	Not latched	DAC left and DAC right volume do not update until a 1 is written to DACVU (in reg 11 or 12)

**Table 31 DAC Digital Volume Control**

**Note:** An additional gain of up to +12dB can be added using the gain block embedded in the digital peak limiter circuit (see DAC OUTPUT LIMITER section).

### 5-BAND EQUALISER

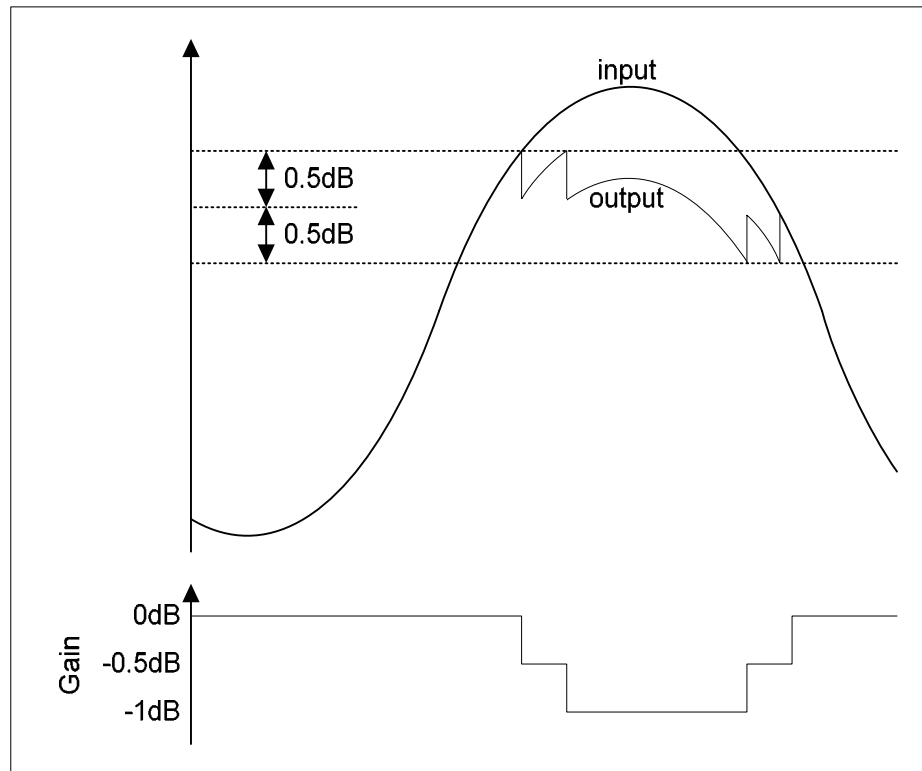
A 5-band graphic equaliser function which can be used to change the output frequency levels to suit the environment. This can be applied to the ADC or DAC path and is described in the 5-BAND EQUALISER section for further details on this feature.

### 3-D ENHANCEMENT

The WM8978 has an advanced digital 3-D enhancement feature which can be used to vary the perceived stereo separation of the left and right channels. Like the 5-band equaliser this feature can be applied to either the ADC record path or the DAC playback path but not both simultaneously. See the 3-D STEREO ENHANCEMENT section for further details on this feature.

### DAC DIGITAL OUTPUT LIMITER

The WM8978 has a digital output limiter function. The operation of this is shown in Figure 27. In this diagram the upper graph shows the envelope of the input/output signals and the lower graph shows the gain characteristic.



**Figure 27 DAC Digital Limiter Operation**

The limiter has a programmable upper threshold which is close to 0dB. Referring to Figure 27, in normal operation (LIMBOOST=000 => limit only) signals below this threshold are unaffected by the limiter. Signals above the upper threshold are attenuated at a specific attack rate (set by the LIMATK register bits) until the signal falls below the threshold. The limiter also has a lower threshold 1dB below the upper threshold. When the signal falls below the lower threshold the signal is amplified at a specific decay rate (controlled by LIMDCY register bits) until a gain of 0dB is reached. Both threshold levels are controlled by the LIMLVL register bits. The upper threshold is 0.5dB above the value programmed by LIMLVL and the lower threshold is 0.5dB below the LIMLVL value.

#### **VOLUME BOOST**

The limiter has programmable upper gain which boosts signals below the threshold to compress the dynamic range of the signal and increase its perceived loudness. This operates as an ALC function with limited boost capability. The volume boost is from 0dB to +12dB in 1dB steps, controlled by the LIMBOOST register bits.

The output limiter volume boost can also be used as a stand alone digital gain boost when the limiter is disabled.

REGISTER ADDRESS	BIT	LABEL	DEFAULT	DESCRIPTION
R24 DAC digital limiter control 1	3:0	LIMATK	0010	Limiter Attack time (per 6dB gain change) for 44.1kHz sampling. Note that these will scale proportionally with sample rate. 0000=94us 0001=188s 0010=375us 0011=750us 0100=1.5ms 0101=3ms 0110=6ms 0111=12ms 1000=24ms 1001=48ms 1010=96ms 1011 to 1111=192ms
	7:4	LIMDCY	0011	Limiter Decay time (per 6dB gain change) for 44.1kHz sampling. Note that these will scale proportionally with sample rate: 0000=750us 0001=1.5ms 0010=3ms 0011=6ms 0100=12ms 0101=24ms 0110=48ms 0111=96ms 1000=192ms 1001=384ms 1010=768ms 1011 to 1111=1.536s
	8	LIMEN	0	Enable the DAC digital limiter: 0=disabled 1=enabled
R25 DAC digital limiter control 2	3:0	LIMBOOST	0000	Limiter volume boost (can be used as a stand alone volume boost when LIMEN=0): 0000=0dB 0001=+1dB 0010=+2dB ... (1dB steps) 1011=+11dB 1100=+12dB 1101 to 1111=reserved



	6:4	LIMLVL	000	Programmable signal threshold level (determines level at which the limiter starts to operate) 000=-1dB 001=-2dB 010=-3dB 011=-4dB 100=-5dB 101 to 111=-6dB
--	-----	--------	-----	--

Table 32 DAC Digital Limiter Control

**5-BAND GRAPHIC EQUALISER**

A 5-band graphic equaliser (EQ) is provided, which can be applied to the ADC or DAC path, together with 3D enhancement, under control of the EQ3DMODE register bit.

REGISTER ADDRESS	BIT	LABEL	DEFAULT	DESCRIPTION
R18 EQ Control 1	8	EQ3DMODE	1	0 = Equaliser and 3D Enhancement applied to ADC path 1 = Equaliser and 3D Enhancement applied to DAC path

Table 33 EQ and 3D Enhancement DAC or ADC Path Select

The equaliser consists of low and high frequency shelving filters (Band 1 and 5) and three peak filters for the centre bands. Each has adjustable cut-off or centre frequency, and selectable boost (+/- 12dB in 1dB steps). The peak filters have selectable bandwidth.

REGISTER ADDRESS	BIT	LABEL	DEFAULT	DESCRIPTION
R18 EQ Band 1 Control	4:0	EQ1G	01100 (0dB)	Band 1 Gain Control. See Table 39 for details.
	6:5	EQ1C	01	Band 1 Cut-off Frequency: 00=80Hz 01=105Hz 10=135Hz 11=175Hz

Table 34 EQ Band 1 Control

REGISTER ADDRESS	BIT	LABEL	DEFAULT	DESCRIPTION
R19 EQ Band 2 Control	4:0	EQ2G	01100 (0dB)	Band 2 Gain Control. See Table 39 for details.
	6:5	EQ2C	01	Band 2 Centre Frequency: 00=230Hz 01=300Hz 10=385Hz 11=500Hz
	8	EQ2BW	0	Band 2 Bandwidth Control 0=narrow bandwidth 1=wide bandwidth

Table 35 EQ Band 2 Control

REGISTER ADDRESS	BIT	LABEL	DEFAULT	DESCRIPTION
R20 EQ Band 3 Control	4:0	EQ3G	01100 (0dB)	Band 3 Gain Control. See Table 39 for details.
	6:5	EQ3C	01	Band 3 Centre Frequency: 00=650Hz 01=850Hz 10=1.1kHz 11=1.4kHz
	8	EQ3BW	0	Band 3 Bandwidth Control 0=narrow bandwidth 1=wide bandwidth

Table 36 EQ Band 3 Control

REGISTER ADDRESS	BIT	LABEL	DEFAULT	DESCRIPTION
R21 EQ Band 4 Control	4:0	EQ4G	01100 (0dB)	Band 4 Gain Control. See Table 39 for details
	6:5	EQ4C	01	Band 4 Centre Frequency: 00=1.8kHz 01=2.4kHz 10=3.2kHz 11=4.1kHz
	8	EQ4BW	0	Band 4 Bandwidth Control 0=narrow bandwidth 1=wide bandwidth

Table 37 EQ Band 4 Control

REGISTER ADDRESS	BIT	LABEL	DEFAULT	DESCRIPTION
R22 EQ Band 5 Gain Control	4:0	EQ5G	01100 (0dB)	Band 5 Gain Control. See Table 39 for details.
	6:5	EQ5C	01	Band 5 Cut-off Frequency: 00=5.3kHz 01=6.9kHz 10=9kHz 11=11.7kHz

Table 38 EQ Band 5 Control

GAIN REGISTER	GAIN
00000	+12dB
00001	+11dB
00010	+10dB
.... (1dB steps)	
01100	0dB
01101	-1dB
11000	-12dB
11001 to 11111	Reserved

Table 39 Gain Register Table

### 3D STEREO ENHANCEMENT

The WM8978 has a digital 3D enhancement option to increase the perceived separation between the left and right channels. Selection of 3D for record or playback is controlled by register bit EQ3DMODE. Switching this bit from record to playback or from playback to record may only be done when ADC and DAC are disabled. The WM8978 control interface will only allow EQ3DMODE to be changed when ADC and DAC are disabled (ie ADCENL = 0, ADCENR = 0, DACENL = 0 and DACENR = 0).

The DEPTH3D setting controls the degree of stereo expansion.

When 3D enhancement is used, it may be necessary to attenuate the signal by 6dB to avoid limiting.

REGISTER ADDRESS	BIT	LABEL	DEFAULT	DESCRIPTION
R41 (29h) 3D	3:0	DEPTH3D[3:0]	0000	Stereo depth 0000: 0% (minimum 3D effect) 0001: 6.67% .... 1110: 93.3% 1111: 100% (maximum 3D effect)

Table 40 3D Stereo Enhancement Function

### ANALOGUE OUTPUTS

The WM8978 has three sets of stereo analogue outputs. These are:

- LOUT1 and ROUT1 which are normally used to drive a headphone load.
- LOUT2 and ROUT2 – normally used to drive an 8Ω BTL speaker.
- OUT3 and OUT4 – can be configured as a stereo line out (OUT3 is left output and OUT4 is right output). OUT4 can also be used to provide a mono mix of left and right channels.

LOUT2, ROUT2, OUT3 and OUT4 are supplied from SPKVDD and are capable of driving up to 1.5Vrms signals as shown in Figure 28. LOUT1 and ROUT1 are supplied from AVDD and can only drive out a 1V rms signal (AVDD/3.3).

LOUT1, ROUT1, LOUT2 and ROUT2 have individual analogue volume PGAs with -57dB to +6dB ranges.

There are four output mixers in the output signal path, the left and right channel mixers which control the signals to speaker, headphone (and optionally the line outputs) and also dedicated OUT3 and OUT4 mixers.

#### LEFT AND RIGHT OUTPUT CHANNEL MIXERS

The left and right output channel mixers are shown in Figure 28. These mixers allow the AUX inputs, the ADC bypass and the DAC left and right channels to be combined as desired. This allows a mono mix of the DAC channels to be done as well as mixing in external line-in from the AUX or speech from the input bypass path.

The AUX and bypass inputs have individual volume control from -15dB to +6dB and the DAC volume can be adjusted in the digital domain if required. The output of these mixers is connected to both the headphone (LOUT1 and ROUT1) and speaker (LOUT2 and ROUT2) and can optionally be connected to the OUT3 and OUT4 mixers.

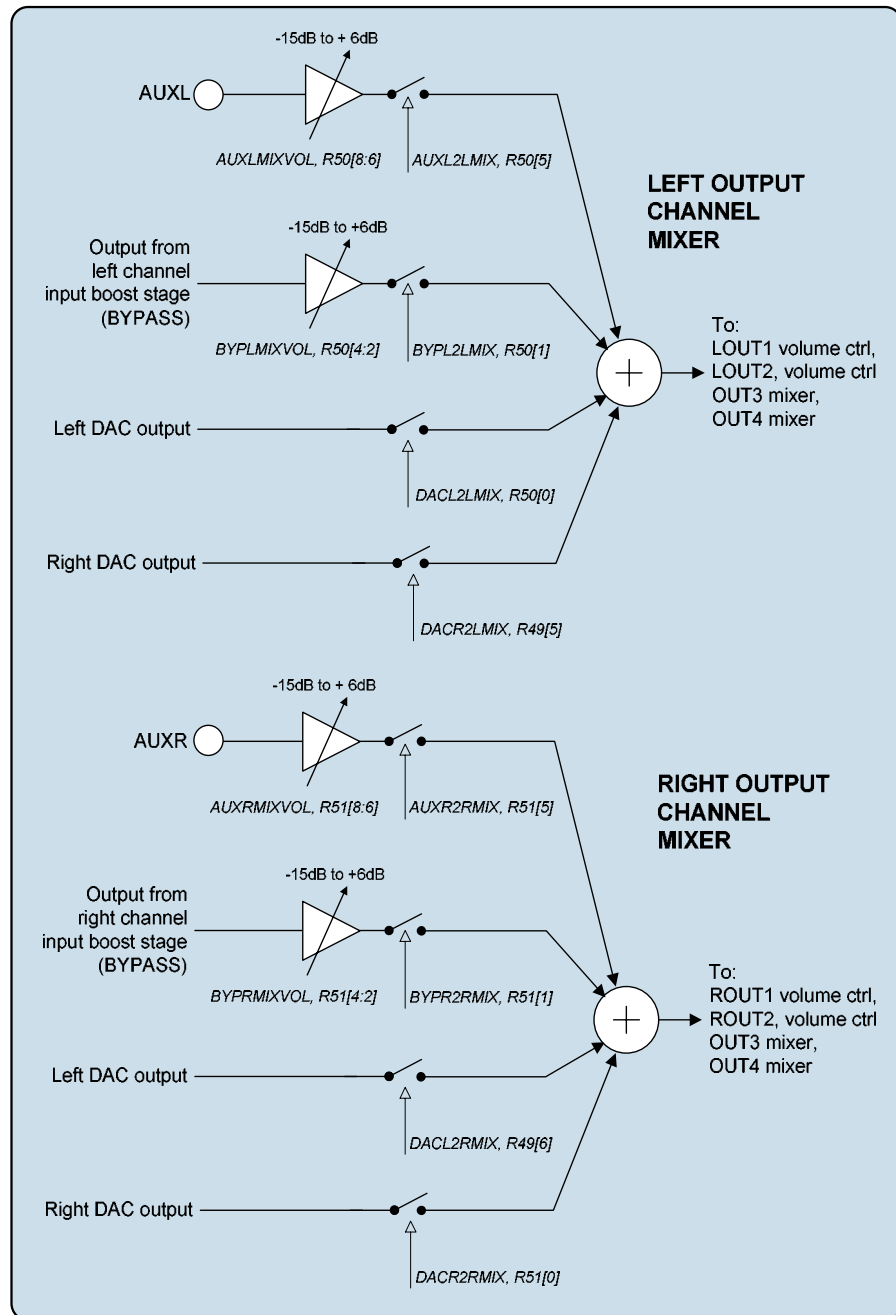


Figure 28 Left/Right Output Channel Mixers

REGISTER ADDRESS	BIT	LABEL	DEFAULT	DESCRIPTION
R49 Output mixer control	5	DACR2LMIX	0	Right DAC output to left output mixer 0 = not selected 1 = selected
	6	DACL2RMIX	0	Left DAC output to right output mixer 0 = not selected 1 = selected
R50 Left channel output mixer control	0	DACL2LMIX	1	Left DAC output to left output mixer 0 = not selected 1 = selected
	1	BYPL2LMIX	0	Left bypass path (from the left channel input boost output) to left output mixer 0 = not selected 1 = selected
	4:2	BYPLMIXVOL	000	Left bypass volume control to output channel mixer: 000 = -15dB 001 = -12dB ... 101 = 0dB 110 = +3dB 111 = +6dB
	5	AUXL2LMIX	0	Left Auxilliary input to left channel output mixer: 0 = not selected 1 = selected
	8:6	AUXLMIXVOL	000	Aux left channel input to left mixer volume control: 000 = -15dB 001 = -12dB ... 101 = 0dB 110 = +3dB 111 = +6dB
R51 Right channel output mixer control	0	DACR2RMIX	1	Right DAC output to right output mixer 0 = not selected 1 = selected
	1	BYPR2RMIX	0	Right bypass path (from the right channel input boost output) to right output mixer 0 = not selected 1 = selected
	4:2	BYPRMIXVOL	000	Right bypass volume control to output channel mixer: 000 = -15dB 001 = -12dB ... 101 = 0dB 110 = +3dB 111 = +6dB

REGISTER ADDRESS	BIT	LABEL	DEFAULT	DESCRIPTION
	5	AUXR2RMIX	0	Right Auxiliary input to right channel output mixer: 0 = not selected 1 = selected
	8:6	AUXRMIXVOL	000	Aux right channel input to right mixer volume control: 000 = -15dB 001 = -12dB ... 101 = 0dB 110 = +3dB 111 = +6dB
R3 Power management 3	2	LMIXEN	0	Left output channel mixer enable: 0 = disabled 1 = enabled
	3	RMIXEN	0	Right output channel mixer enable: 0 = disabled 1 = enabled

Table 41 Left and Right Output Mixer Control

**HEADPHONE OUTPUTS (LOUT1 AND ROUT1)**

The headphone outputs, LOUT1 and ROUT1 can drive a 16Ω or 32Ω headphone load, either through DC blocking capacitors, or DC coupled without any capacitor. Each headphone output has an analogue volume control PGA with a gain range of -57dB to +6dB as shown in Figure 31.

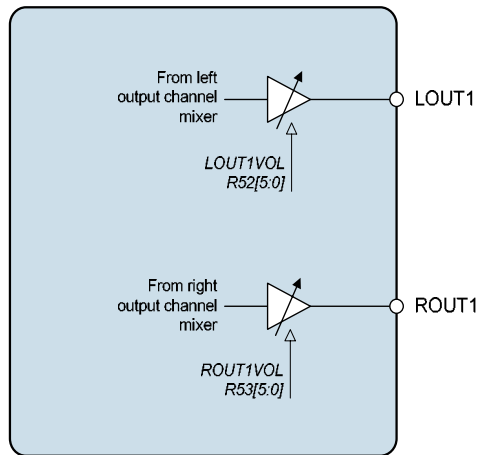
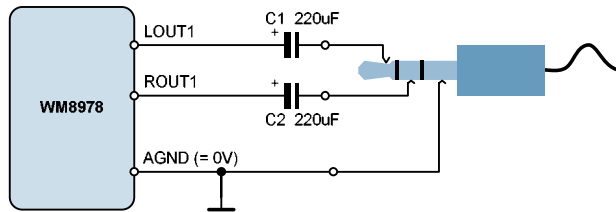


Figure 29 Headphone Outputs LOUT1 and ROUT1

REGISTER ADDRESS	BIT	LABEL	DEFAULT	DESCRIPTION
R52 LOUT1 Volume control	7	LOUT1ZC	0	Headphone volume zero cross enable: 1 = Change gain on zero cross only 0 = Change gain immediately
	6	LOUT1MUTE	0	Left headphone output mute: 0 = Normal operation 1 = Mute
	5:0	LOUT1VOL	111001	Left headphone output volume: 000000 = -57dB ... 111001 = 0dB ... 111111 = +6dB
	8	HPVU	Not latched	LOUT1 and ROUT1 volumes do not update until a 1 is written to HPVU (in reg 52 or 53)
R53 ROUT1 Volume control	7	ROUT1ZC	0	Headphone volume zero cross enable: 1 = Change gain on zero cross only 0 = Change gain immediately
	6	ROUT1MUTE	0	Right headphone output mute: 0 = Normal operation 1 = Mute
	5:0	ROUT1VOL	111001	Right headphone output volume: 000000 = -57dB ... 111001 = 0dB ... 111111 = +6dB
	8	HPVU	Not latched	LOUT1 and ROUT1 volumes do not update until a 1 is written to HPVU (in reg 52 or 53)

Table 42 OUT1 Volume Control

## Headphone Output using DC Blocking Capacitors:



## DC Coupled Headphone Output:

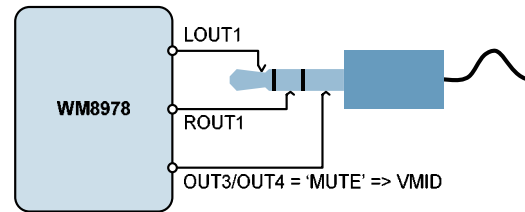


Figure 30 Recommended Headphone Output Configurations

When DC blocking capacitors are used, then their capacitance and the load resistance together determine the lower cut-off frequency,  $f_c$ . Increasing the capacitance lowers  $f_c$ , improving the bass response. Smaller capacitance values will diminish the bass response. Assuming a  $16\Omega$  load and  $C_1, C_2 = 220\mu\text{F}$ :

$$f_c = 1 / 2\pi R_L C_1 = 1 / (2\pi \times 16\Omega \times 220\mu\text{F}) = 45 \text{ Hz}$$

In the DC coupled configuration, the headphone "ground" is connected to the VMID pin. The OUT3/4 pins can be configured as a DC output driver by setting the OUT3MUTE and OUT4MUTE register bit. The DC voltage on VMID in this configuration is equal to the DC offset on the LOUT1 and ROUT1 pins therefore no DC blocking capacitors are required. This saves space and material cost in portable applications.

Note that OUT3 and OUT4 have an optional output boost of 1.5x. When these are configured in this output boost mode (OUT3BOOST/OUT4BOOST=1) then the VMID value of these outputs will be equal to  $1.5 \times \text{AVDD}/2$  and will not match the VMID of the headphone drivers. Do not use the DC coupled output mode in this configuration.

It is recommended to connect the DC coupled outputs only to headphones, and not to the line input of another device. Although the built-in short circuit protection will prevent any damage to the headphone outputs, such a connection may be noisy, and may not function properly if the other device is grounded.

## SPEAKER OUTPUTS (LOUT2 AND ROUT2)

The outputs LOUT2 and ROUT2 are designed to drive an  $8\Omega$  BTL speaker but can optionally drive two headphone loads of  $16\Omega/32\Omega$  or a line output (see Headphone Output and Line Output sections, respectively). Each output has an individual volume control PGA, an output boost/level shift bit, a mute and an enable as shown in Figure 31. LOUT2 and ROUT2 output the left and right channel mixer outputs respectively.

The ROUT2 signal path also has an optional invert. The amplifier used for this invert can be used to mix in the AUXR signal with an adjustable gain range of  $-15\text{dB} \rightarrow +6\text{dB}$ . This allows a 'beep' signal to be applied only to the speaker output without affecting the HP or line outputs.



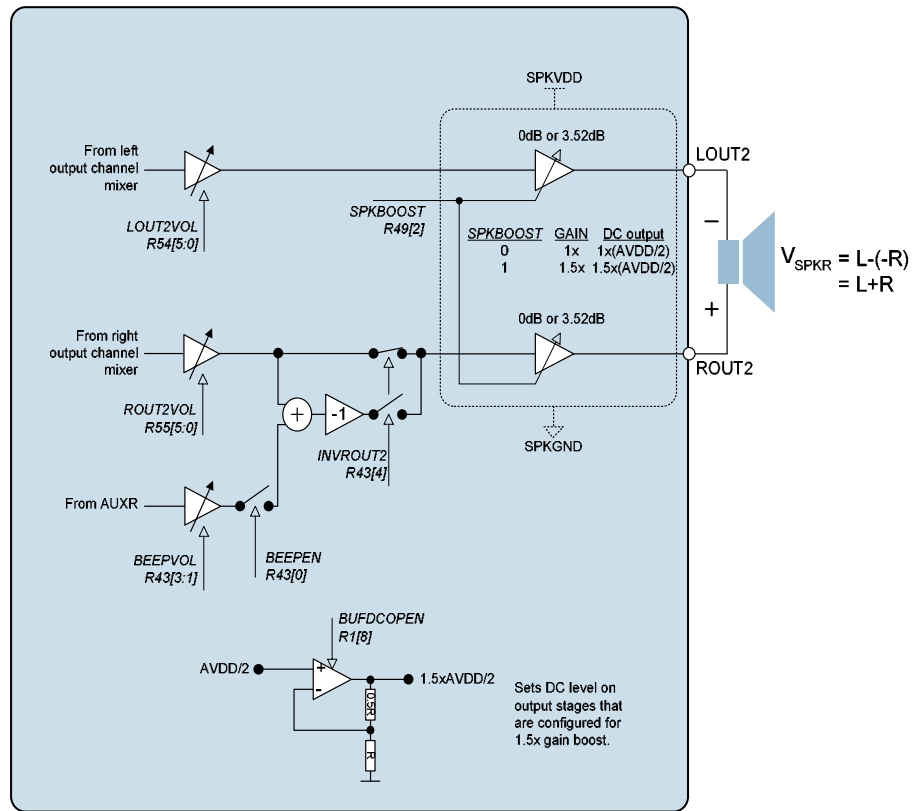


Figure 31 Speaker Outputs LOUT2 and ROUT2

REGISTER ADDRESS	BIT	LABEL	DEFAULT	DESCRIPTION
R54 LOUT2 (SPK) Volume control	7	LOUT2ZC	0	Speaker volume zero cross enable: 1 = Change gain on zero cross only 0 = Change gain immediately
	6	LOUT2MUTE	0	Left speaker output mute: 0 = Normal operation 1 = Mute
	5:0	LOUT2VOL	111001	Left speaker output volume: 000000 = -57dB ... 111001 = 0dB ... 111111 = +6dB
	8	SPKVU	Not latched	LOUT2 and ROUT2 volumes do not update until a 1 is written to SPKVU (in reg 54 or 55)
R55 ROUT2 (SPK) Volume control	7	ROUT2ZC	0	Speaker volume zero cross enable: 1 = Change gain on zero cross only 0 = Change gain immediately
	6	ROUT2MUTE	0	Right speaker output mute: 0 = Normal operation 1 = Mute
	5:0	ROUT2VOL	111001	Right speaker output volume: 000000 = -57dB ... 111001 = 0dB ... 111111 = +6dB
	8	SPKVU	Not latched	LOUT2 and ROUT2 volumes do not update until a 1 is written to SPKVU (in reg 54 or 55)

**Table 43 Speaker Volume Control**

The signal output on LOUT2/ROUT2 comes from the Left/Right Mixer circuits and can be any combination of the DAC output, the Bypass path (output of the input boost stage) and the AUX input. The LOUT2/ROUT2 volume is controlled by the LOUT2VOL/ ROUT2VOL register bits. Gains over 0dB may cause clipping if the signal is large. The LOUT2MUTE/ ROUT2MUTE register bits cause the speaker outputs to be muted (the output DC level is driven out). The output pins remain at the same DC level (DCOP), so that no click noise is produced when muting or un-muting

The speaker output stages also have a selectable gain boost of 1.5x (3.52dB). When this boost is enabled the output DC level is also level shifted (from AVDD/2 to 1.5xAVDD/2) to prevent the signal from clipping. A dedicated amplifier BUFDCOP, as shown in Figure 32, is used to perform the DC level shift operation. This buffer must be enabled using the BUFDCOPEN register bit for this operating mode. It should also be noted that if SPKVDD is not equal to or greater than 1.5xAVDD this boost mode may result in signals clipping. Table 45 summarises the effect of the SPKBOOST control bits.

REGISTER ADDRESS	BIT	LABEL	DEFAULT	DESCRIPTION
R49 Output control	2	SPKBOOST	0	0 = speaker gain = -1; DC = AVDD / 2 1 = speaker gain = +1.5; DC = 1.5 x AVDD / 2
R1 Power management 1	8	BUFDOPEN	0	Dedicated buffer for DC level shifting output stages when in 1.5x gain boost configuration. 0=Buffer disabled 1=Buffer enabled (required for 1.5x gain boost)

Table 44 Speaker Boost Stage Control

SPKBOOST	OUTPUT STAGE GAIN	OUTPUT DC LEVEL	OUTPUT STAGE CONFIGURATION
0	1x (0dB)	AVDD/2	Inverting
1	1.5x (3.52dB)	1.5xAVDD/2	Non-inverting

Table 45 Output Boost Stage Details

REGISTER ADDRESS	BIT	LABEL	DEFAULT	DESCRIPTION
R43 Beep control	5	MUTERPGA2INV	0	Mute input to INVROUT2 mixer
	4	INVROUT2	0	Invert ROUT2 output
	3:1	BEEPVOL	000	AUXR input to ROUT2 inverter gain 000 = -15dB ... 111 = +6dB
	0	BEEPEN	0	0 = mute AUXR beep input 1 = enable AUXR beep input

Table 46 AUXR – ROUT2 BEEP Mixer Function

### ZERO CROSS TIMEOUT

A zero-cross timeout function is also provided so that if zero cross is enabled on the input or output PGAs the gain will automatically update after a timeout period if a zero cross has not occurred. This is enabled by setting SLOWCLKEN. The timeout period is dependent on the clock input to the digital and is equal to  $2^{21}$  \* input clock period.

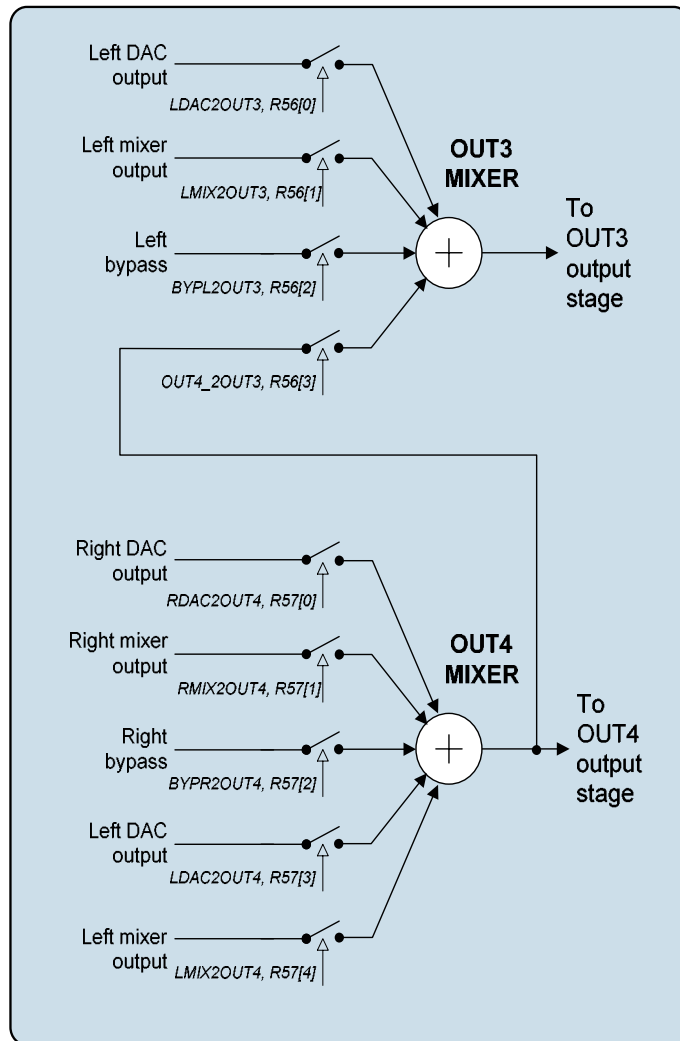
REGISTER ADDRESS	BIT	LABEL	DEFAULT	DESCRIPTION
R7 Additional Control	0	SLOWCLKEN	0	Slow clock enable. Used for both the jack insert detect debounce circuit and the zero cross timeout. 0 = slow clock disabled 1 = slow clock enabled

Table 47 Timeout Clock Enable Control

### OUT3/OUT4 MIXERS AND OUTPUT STAGES

The OUT3/OUT4 pins can provide an additional stereo line output, a mono output, or a pseudo ground connection for headphones. There is a dedicated analogue mixer for OUT3 and one for OUT4 as shown in Figure 33.

The OUT3 and OUT4 output stages are powered from SPKVDD and SPKGND. The individually controllable outputs also incorporate an optional 1.5x boost and level shifting stage.



**Figure 33 OUT3 and OUT4 Mixers**

OUT3 can provide a buffered midrail headphone pseudo-ground, or a left line output.

OUT4 can provide a buffered midrail headphone pseudo-ground, a right line output, or a mono mix output.

REGISTER ADDRESS	BIT	LABEL	DEFAULT	DESCRIPTION
R56 OUT3 mixer control	6	OUT3MUTE	0	0 = Output stage outputs OUT3 mixer 1 = Output stage muted – drives out VMID. Can be used as VMID buffer in this mode.
	3	OUT4_2OUT3	0	OUT4 mixer output to OUT3 0 = disabled 1= enabled
	2	BYPL2OUT3	0	Left ADC input to OUT3 0 = disabled 1= enabled
	1	LMIX2OUT3	0	Left DAC mixer to OUT3 0 = disabled 1= enabled
	0	LDAC2OUT3	1	Left DAC output to OUT3 0 = disabled 1= enabled
R57 OUT4 mixer control	6	OUT4MUTE	0	0 = Output stage outputs OUT4 mixer 1 = Output stage muted – drives out VMID. Can be used as VMID buffer in this mode.
	5	HALFSIG	0	0=OUT4 normal output 1=OUT4 attenuated by 6dB
	4	LMIX2OUT4	0	Left DAC mixer to OUT4 0 = disabled 1= enabled
	3	LDAC2OUT4	0	Left DAC to OUT4 0 = disabled 1= enabled
	2	BYPR2OUT4	0	Right ADC input to OUT4 0 = disabled 1= enabled
	1	RMIX2OUT4	0	Right DAC mixer to OUT4 0 = disabled 1= enabled
	0	RDAC2OUT4	1	Right DAC output to OUT4 0 = disabled 1= enabled

**Table 48 OUT3/OUT4 Mixer Registers**

The OUT3 and OUT4 output stages each have a selectable gain boost of 1.5x (3.52dB). When this boost is enabled the output DC level is also level shifted (from AVDD/2 to 1.5xAVDD/2) to prevent the signal from clipping. A dedicated amplifier BUFDCOP, as shown in Figure 34, is used to perform the DC level shift operation. This buffer must be enabled using the BUFDCOPEN register bit for this operating mode. It should also be noted that if SPKVDD is not equal to or greater than 1.5xAVDD this boost mode may result in signals clipping. Table 45 summarises the effect of the OUT3BOOST and OUT4BOOST control bits.

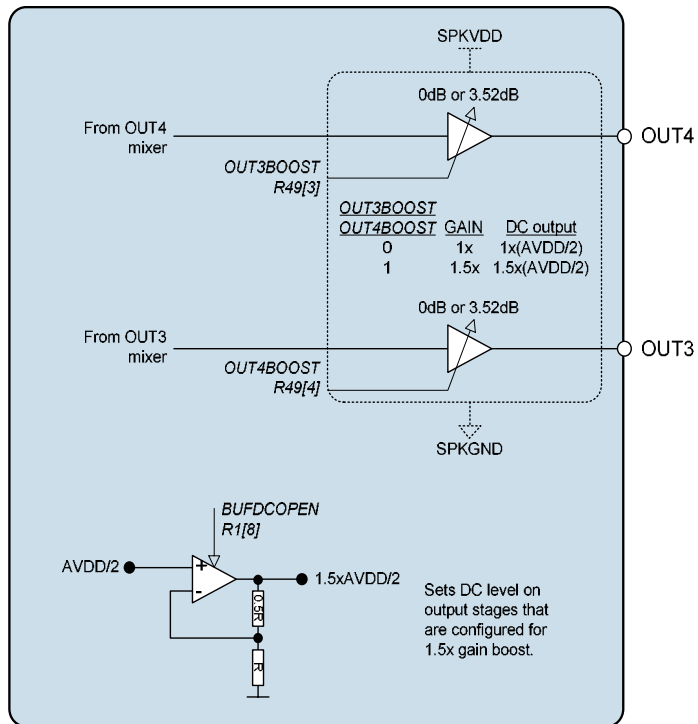


Figure 35 Outputs OUT3 and OUT4

REGISTER ADDRESS	BIT	LABEL	DEFAULT	DESCRIPTION
R49 Output control	3	OUT3BOOST	0	0 = OUT3 output gain = -1; DC = AVDD / 2 1 = OUT3 output gain = +1.5 DC = 1.5 x AVDD / 2
	4	OUT4BOOST	0	0 = OUT4 output gain = -1; DC = AVDD / 2 1 = OUT4 output gain = +1.5 DC = 1.5 x AVDD / 2
R1 Power management 1	8	BUFDCOPEN	0	Dedicated buffer for DC level shifting output stages when in 1.5x gain boost configuration. 0=Buffer disabled 1=Buffer enabled (required for 1.5x gain boost)

Table 49 OUT3 and OUT4 Boost Stages Control

OUT3BOOST/ OUT4BOOST	OUTPUT STAGE GAIN	OUTPUT DC LEVEL	OUTPUT STAGE CONFIGURATION
0	1x	AVDD/2	Inverting
1	1.5x	1.5xAVDD/2	Non-inverting

Table 50 OUT3/OUT4 Output Boost Stage Details

## OUTPUT PHASING

The relative phases of the analogue outputs will depend upon the following factors:

1. DACPOLLR and DACPOLR invert bits: Setting these bits to 1 will invert the DAC output.
2. Mixer configuration: The polarity of the signal will depend upon the route through the mixer path. For example, DACL can be directly input to the OUT3 mixer, giving a 180° phase shift at the OUT3 mixer output. However, if DACL is input to the OUT3 mixer via the left mixer, an additional phase shift will be introduced, giving 0° phase shift at the OUT3 mixer output.
3. Output boost set-up: When 1.5x boost is enabled on an output, no phase shift occurs. When 1.5x boost is not enabled, a 180° phase shift occurs.

Figure 28 shows where these phase inversions can occur in the output signal path.

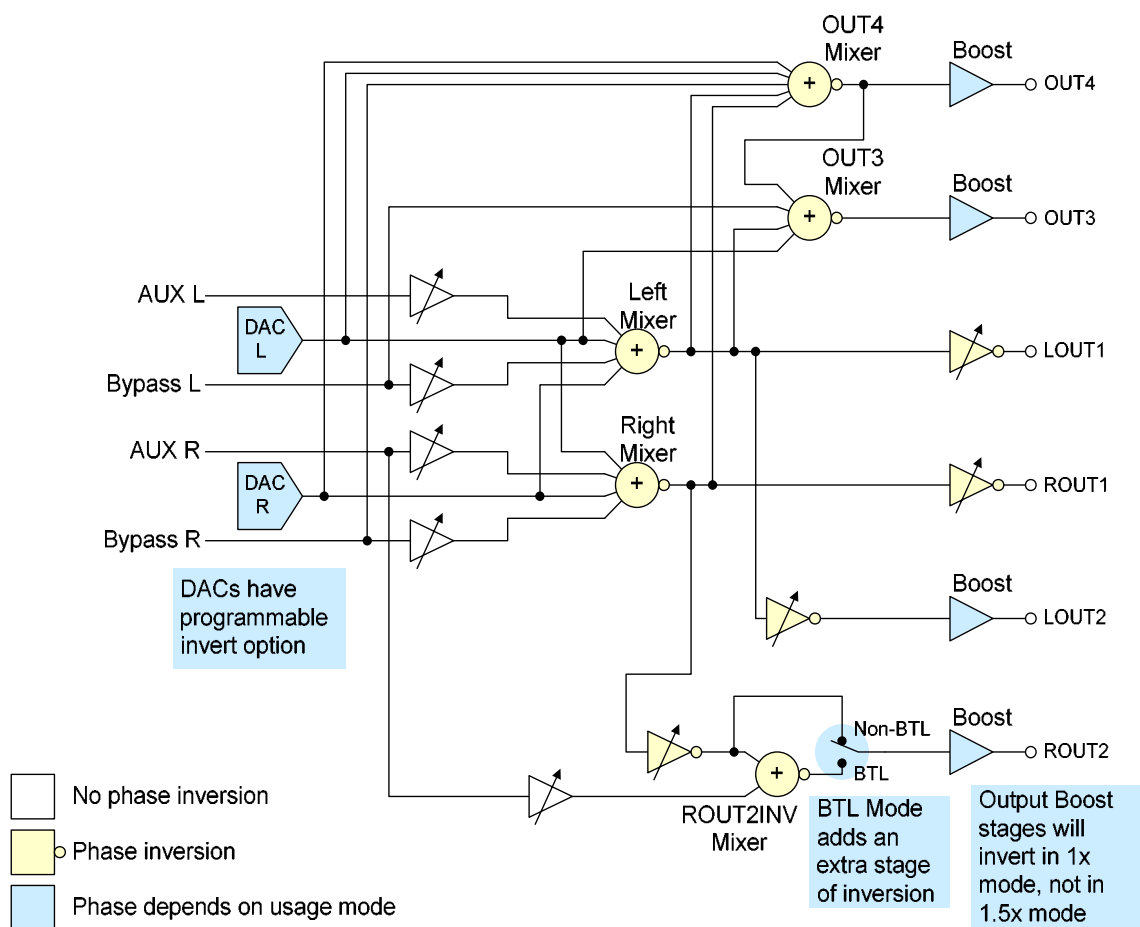


Figure 36 Output Signal Path Phasing

Table 51 shows the polarities of the outputs in various configurations.

Unless otherwise stated, polarity is shown with respect to left DAC output in non-inverting mode.

Note that only registers relating to the mixer paths are shown here (Mixer enables, volume settings, output enables etc are not shown).

CONFIGURATION	DACPOLL	DACPOLR	INVROUT2	SPKBOOST	OUT3BOOST	OUT4BOOST	MIXER PATH REGISTERS DIFFERENT FROM DEFAULT	OUT4 PHASE / MAG	OUT3 PHASE / MAG	LOUT1 PHASE / MAG	ROUT1 PHASE / MAG	LOUT2 PHASE / MAG	ROUT2 PHASE / MAG
Default: Stereo DAC playback to LOUT1/ROUT1, LOUT2/ROUT2 and OUT4/OUT3	0	0	0	0	0	0		0° 1	0° 1	0° 1	0° 1	180° 1	180° 1
DACs inverted	1	1	0	0	0	0		180° 1	180° 1	180° 1	180° 1	0° 1	0° 1
Stereo DAC playback to LOUT1/ROUT1 and LOUT2/ROUT2 and OUT4/OUT3 (Speaker boost enabled)	0	0	0	1	0	0		0° 1	0° 1	0° 1	0° 1	0° 1.5	0° 1.5
Stereo DAC playback to LOUT1/ROUT1 and LOUT2/ROUT2 and OUT4/OUT3 (OUT3 and OUT4 boost enabled)	0	0	0	0	1	1		180° 1.5	180° 1.5	0° 1	0° 1	180° 1	180° 1
Stereo playback to OUT3/OUT4 (DACs input to OUT3/OUT4 mixers via left/right mixers)	0	0	0	0	0	0	LDAC2OUT3=0 RDAC2OUT4=0 LMIX2OUT3=1 RMIX2OUT4=1	180° 1	180° 1	0° 1	0° 1	180° 1	180° 1
Differential output of right bypass path via OUT3/OUT4 (Phase shown relative to right bypass)	0	0	0	0	0	0	BYPR2OUT4=1 OUT4_2OUT3=1	180° 1	0° 1	X	X	X	X
Differential output of mono mix of DACs via LOUT2/ROUT2 (e.g. BTL speaker drive)	0	0	1	0	0	0		0° 1	0° 1	0° 1	0° 1	180° 1	0° 1
High power speaker drive	0	0	1	1	0	0		0° 1	0° 1	0° 1	0° 1	0° 1.5	180° 1.5

**Table 51 Relative Output Phases**

Note that differential output should not be set up by combining outputs in boost mode with outputs which are not in boost mode as this would cause a DC offset current on the outputs.



## ENABLING THE OUTPUTS

Each analogue output of the WM8978 can be separately enabled or disabled. The analogue mixer associated with each output has a separate enable. All outputs are disabled by default. To save power, unused parts of the WM8978 should remain disabled.

Outputs can be enabled at any time, but it is not recommended to do so when BUFIO is disabled (BUFIOEN=0) or when BUFDCOP is disabled (BUFDCOPEN=0) when configured in output boost mode, as this may cause pop noise (see "Power Management" and "Applications Information" sections).

REGISTER ADDRESS	BIT	LABEL	DEFAULT	DESCRIPTION
R1 Power Management 1	2	BUFIOEN	0	Unused input/output tie off buffer enable
	6	OUT3MIXEN	0	OUT3 mixer enable
	7	OUT4MIXEN	0	OUT4 mixer enable
	8	BUFDCOPEN	0	Output stage 1.5xAVDD/2 driver enable
R2 Power Management 2	8	ROUT1EN	0	ROUT1 output enable
	7	LOUT1EN	0	LOUT1 output enable
	6	SLEEP	0	0 = normal device operation 1 = residual current reduced in device standby mode if clocks still running
R3 Power Management 3	2	LMIXEN	0	Left mixer enable
	3	RMIXEN	0	Right mixer enable
	5	ROUT2EN	0	ROUT2 output enable
	6	LOUT2EN	0	LOUT2 output enable
	7	OUT3EN	0	OUT3 enable
	8	OUT4EN	0	OUT4 enable
<b>Note:</b> All "Enable" bits are 1 = ON, 0 = OFF				

**Table 52 Output Stages Power Management Control**

## THERMAL SHUTDOWN

The speaker outputs can drive very large currents. To protect the WM8978 from overheating a thermal shutdown circuit is included. If the device temperature reaches approximately 125°C and the thermal shutdown circuit is enabled (TSDEN=1) then the speaker amplifiers will be disabled if TSDEN is set. The thermal shutdown may also be configured to generate an interrupt. See the GPIO and Interrupt Controller section for details.

REGISTER ADDRESS	BIT	LABEL	DEFAULT	DESCRIPTION
R49 Output control	1	TSDEN	1	Thermal Shutdown Enable 0 : thermal shutdown disabled 1 : thermal shutdown enabled

**Table 53 Thermal Shutdown**

## UNUSED ANALOGUE INPUTS/OUTPUTS

Whenever an analogue input/output is disabled, it remains connected to a voltage source (either AVDD/2 or 1.5xAVDD/2 as appropriate) through a resistor. This helps to prevent pop noise when the output is re-enabled. The resistance between the voltage buffer and the output pins can be controlled using the VROI control bit. The default impedance is low, so that any capacitors on the outputs can charge up quickly at start-up. If a high impedance is desired for disabled outputs, VROI can then be set to 1, increasing the resistance to about 30kΩ.

REGISTER ADDRESS	BIT	LABEL	DEFAULT	DESCRIPTION
R49	0	VROI	0	VREF (AVDD/2 or 1.5xAVDD/2) to analogue output resistance 0: approx 1kΩ 1: approx 30 kΩ

**Table 54 Disabled Outputs to VREF Resistance**

A dedicated buffer is available for tying off unused analogue I/O pins as shown in Figure 37. This buffer can be enabled using the BUFIOEN register bit.

If the SPKBOOST, OUT3BOOST or OUT4BOOST bits are set then the relevant outputs will be tied to the output of the DC level shift buffer at  $1.5 \times AVDD/2$  when disabled.

Figure 37 summarises the tie-off options for the speaker and mono output pins.

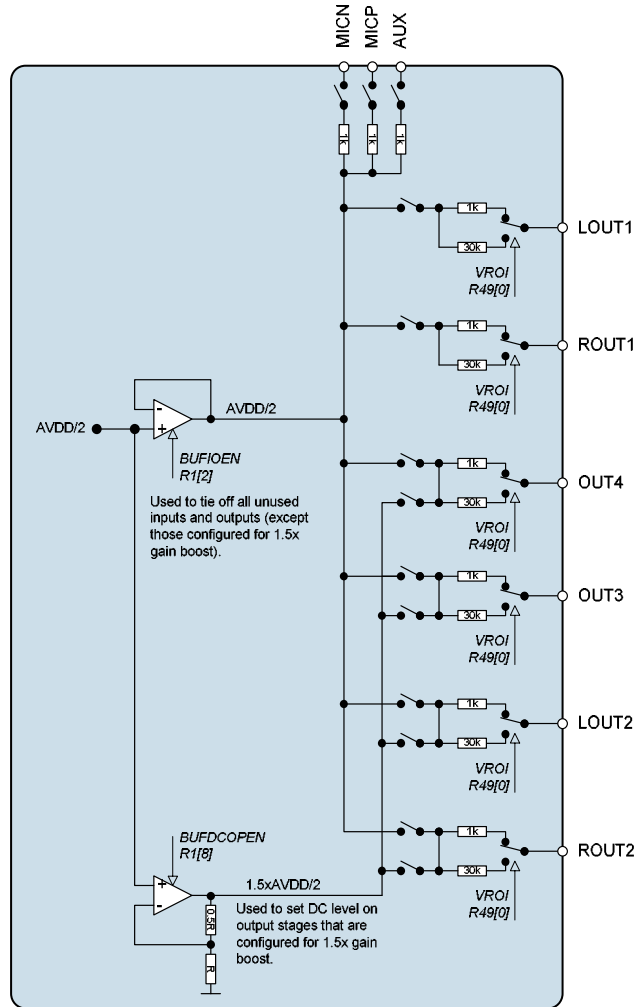


Figure 37 Unused Input/Output Pin Tie-off Buffers

L/ROUT2EN/ OUT3/4EN	OUT3BOOST/ OUT4BOOST/ SPKBOOST	VROI	OUTPUT CONFIGURATION
0	0	0	1kΩ tie-off to AVDD/2
0	0	1	30kΩ tie-off to AVDD/2
0	1	0	1kΩ tie-off to $1.5 \times AVDD/2$
0	1	1	30kΩ tie-off to $1.5 \times AVDD/2$
1	0	X	Output enabled (DC level=AVDD/2)
1	1	X	Output enabled (DC level= $1.5 \times AVDD/2$ )

Table 55 Unused Output Pin Tie-off Options

## DIGITAL AUDIO INTERFACES

The audio interface has four pins:

- ADCDAT: ADC data output
- DACDAT: DAC data input
- LRC: Data Left/Right alignment clock
- BCLK: Bit clock, for synchronisation

The clock signals BCLK, and LRC can be outputs when the WM8978 operates as a master, or inputs when it is a slave (see Master and Slave Mode Operation, below).

Five different audio data formats are supported:

- Left justified
- Right justified
- I<sup>2</sup>S
- DSP mode A
- DSP mode B

All of these modes are MSB first. They are described in Audio Data Formats, below. Refer to the Electrical Characteristic section for timing information.

### MASTER AND SLAVE MODE OPERATION

The WM8978 audio interface may be configured as either master or slave. As a master interface device the WM8978 generates BCLK and LRC and thus controls sequencing of the data transfer on ADCDAT and DACDAT. To set the device to master mode register bit MS should be set high. In slave mode (MS=0), the WM8978 responds with data to clocks it receives over the digital audio interfaces.

### AUDIO DATA FORMATS

In Left Justified mode, the MSB is available on the first rising edge of BCLK following an LRC transition. The other bits up to the LSB are then transmitted in order. Depending on word length, BCLK frequency and sample rate, there may be unused BCLK cycles before each LRC transition.

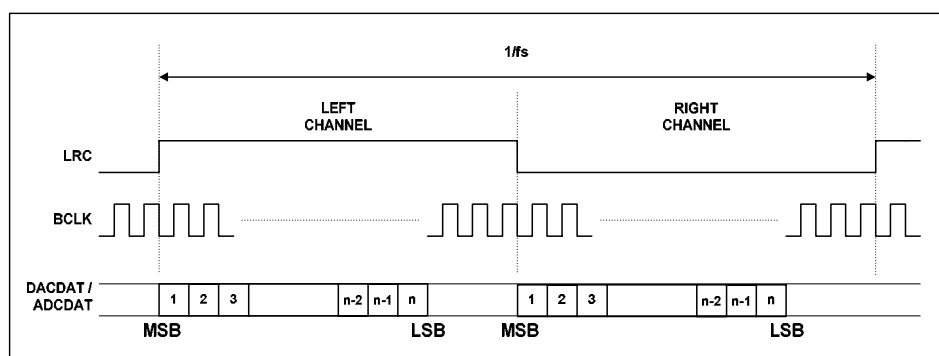


Figure 38 Left Justified Audio Interface (assuming n-bit word length)

In Right Justified mode, the LSB is available on the last rising edge of BCLK before a LRC transition. All other bits are transmitted before (MSB first). Depending on word length, BCLK frequency and sample rate, there may be unused BCLK cycles after each LRC transition.

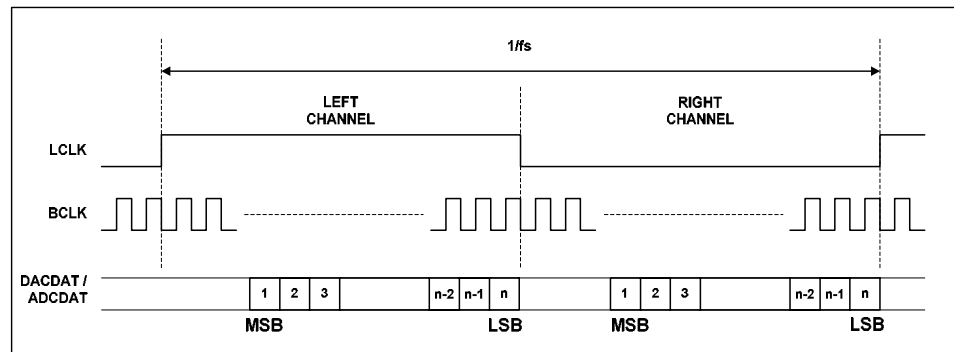


Figure 39 Right Justified Audio Interface (assuming n-bit word length)

In I<sup>2</sup>S mode, the MSB is available on the second rising edge of BCLK following a LRC transition. The other bits up to the LSB are then transmitted in order. Depending on word length, BCLK frequency and sample rate, there may be unused BCLK cycles between the LSB of one sample and the MSB of the next.

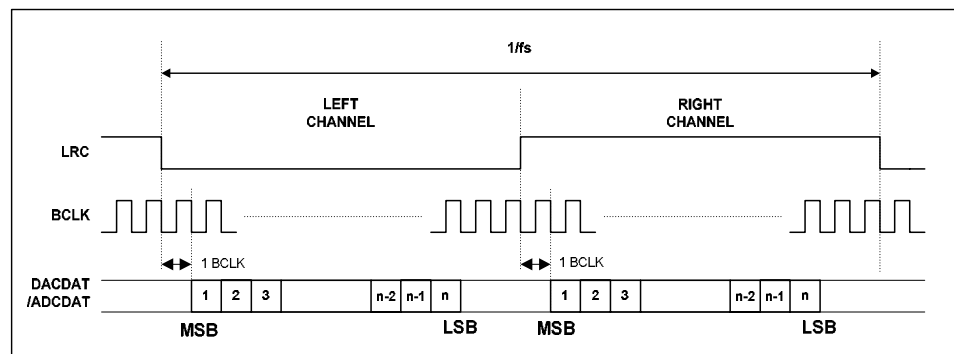


Figure 40 I<sup>2</sup>S Audio Interface (assuming n-bit word length)

In DSP/PCM mode, the left channel MSB is available on either the 1<sup>st</sup> (mode B) or 2<sup>nd</sup> (mode A) rising edge of BCLK (selectable by LRP) following a rising edge of LRC. Right channel data immediately follows left channel data. Depending on word length, BCLK frequency and sample rate, there may be unused BCLK cycles between the LSB of the right channel data and the next sample.

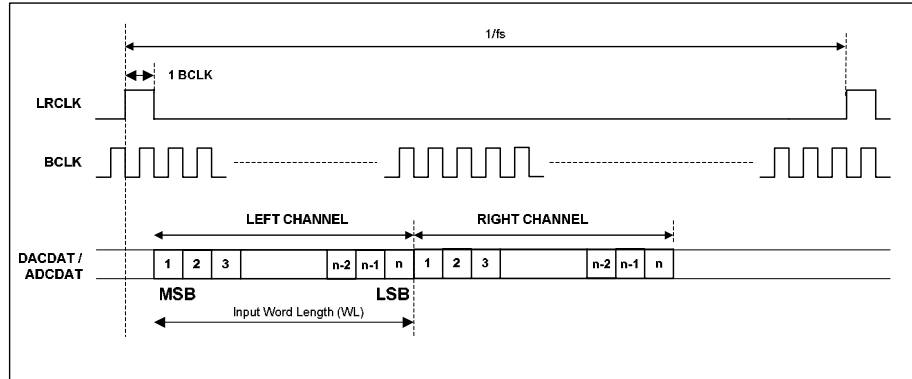


Figure 41 DSP/PCM Mode Audio Interface (mode A, LCRP=0)

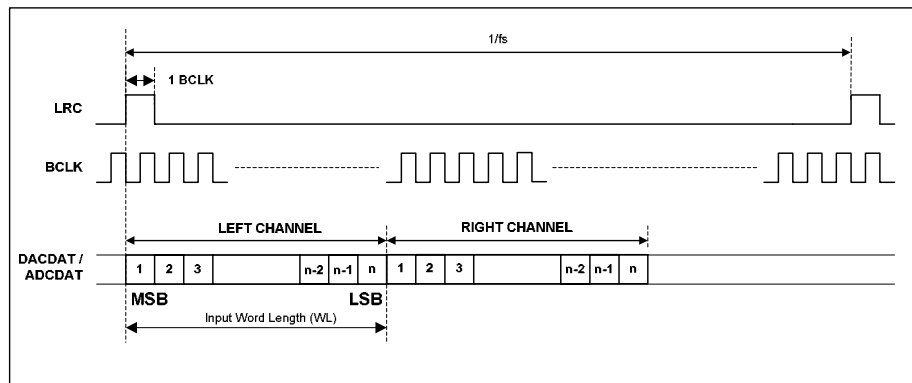


Figure 42 DSP/PCM Mode Audio Interface (mode B, LCRP=1)

REGISTER ADDRESS	BIT	LABEL	DEFAULT	DESCRIPTION
R4 Audio Interface Control	0	MONO	0	Selects between stereo and mono device operation: 0=Stereo device operation 1=Mono device operation. Data appears in 'left' phase of LRC
	1	ADCLRSWAP	0	Controls whether ADC data appears in 'right' or 'left' phases of LRC clock: 0=ADC data appear in 'left' phase of LRC 1=ADC data appears in 'right' phase of LRC
	2	DACLRSWAP	0	Controls whether DAC data appears in 'right' or 'left' phases of LRC clock: 0=DAC data appear in 'left' phase of LRC 1=DAC data appears in 'right' phase of LRC
	4:3	FMT	10	Audio interface Data Format Select: 00=Right Justified 01=Left Justified 10=I <sup>2</sup> S format 11= DSP/PCM mode
	6:5	WL	10	Word length 00=16 bits 01=20 bits 10=24 bits 11=32 bits (see note)
	7	LRP		LRC clock polarity 0=normal 1=inverted
	8	BCP		BCLK polarity 0=normal 1=inverted

**Table 56 Audio Interface Control**

**Note:** Right Justified Mode will only operate with a maximum of 24 bits. If 32-bit mode is selected, the device will operate in 24-bit mode.

#### AUDIO INTERFACE CONTROL

The register bits controlling audio format, word length and master / slave mode are summarised below. The audio interfaces can be controlled individually.

Register bit MS selects audio interface operation in master or slave mode. In Master mode BCLK, and LRC are outputs. The frequency of BCLK in master mode are controlled with BCLKDIV. These are divided down versions of master clock. .

REGISTER ADDRESS	BIT	LABEL	DEFAULT	DESCRIPTION
R6 Clock Generation Control	0	MS	0	Sets the chip to be master over LRC and BCLK 0=BCLK and LRC clock are inputs 1=BCLK and LRC clock are outputs generated by the WM8978 (MASTER)
	4:2	BCLKDIV	000	Configures the BCLK output frequency, for use when the chip is master over BCLK. 000=divide by 1 (BCLK=SYSCLK) 001=divide by 2 (BCLK=SYSCLK) 010=divide by 4 011=divide by 8 100=divide by 16 101=divide by 32 110=reserved 111=reserved
	7:5	MCLKDIV	010	Sets the scaling for either the MCLK or PLL clock output (under control of CLKSEL) 000=divide by 1 001=divide by 1.5 010=divide by 2 011=divide by 3 100=divide by 4 101=divide by 6 110=divide by 8 111=divide by 12
	8	CLKSEL	1	Controls the source of the clock for all internal operation: 0=MCLK 1=PLL output

Table 57 Clock Control

## AUDIO SAMPLE RATES

The WM8978 sample rates for the ADCs and the DACs are set using the SR register bits. The cutoffs for the digital filters and the ALC attack/decay times stated are determined using these values and assume a 256fs master clock rate.

If a sample rate that is not explicitly supported by the SR register settings is required then the closest SR value to that sample rate should be chosen, the filter characteristics and the ALC attack, decay and hold times will scale appropriately.

REGISTER ADDRESS	BIT	LABEL	DEFAULT	DESCRIPTION
R7 Additional Control	3:1	SR	000	Approximate sample rate (configures the coefficients for the internal digital filters): 000=48kHz 001=32kHz 010=24kHz 011=16kHz 100=12kHz 101=8kHz 110-111=reserved

Table 58 Sample Rate Control

## MASTER CLOCK AND PHASE LOCKED LOOP (PLL)

The WM8978 has an on-chip phase-locked loop (PLL) circuit that can be used to:

Generate master clocks for the WM8978 audio functions from another external clock, e.g. in telecoms applications.

Generate and output (on pin CSB/GPIO1 and/or GPIO4) a clock for another part of the system that is derived from an existing audio master clock.

Figure 43 shows the PLL and internal clocking arrangement on the WM8978.

The PLL can be enabled or disabled by the PLEN register bit.

Note: In order to minimise current consumption, the PLL is disabled when the VMIDSEL[1:0] bits are set to 00b. VMIDSEL[1:0] must be set to a value other than 00b to enable the PLL.

REGISTER ADDRESS	BIT	LABEL	DEFAULT	DESCRIPTION
R1 Power management 1	5	PLEN	0	PLL enable 0=PLL off 1=PLL on

Table 59 PLEN Control Bit



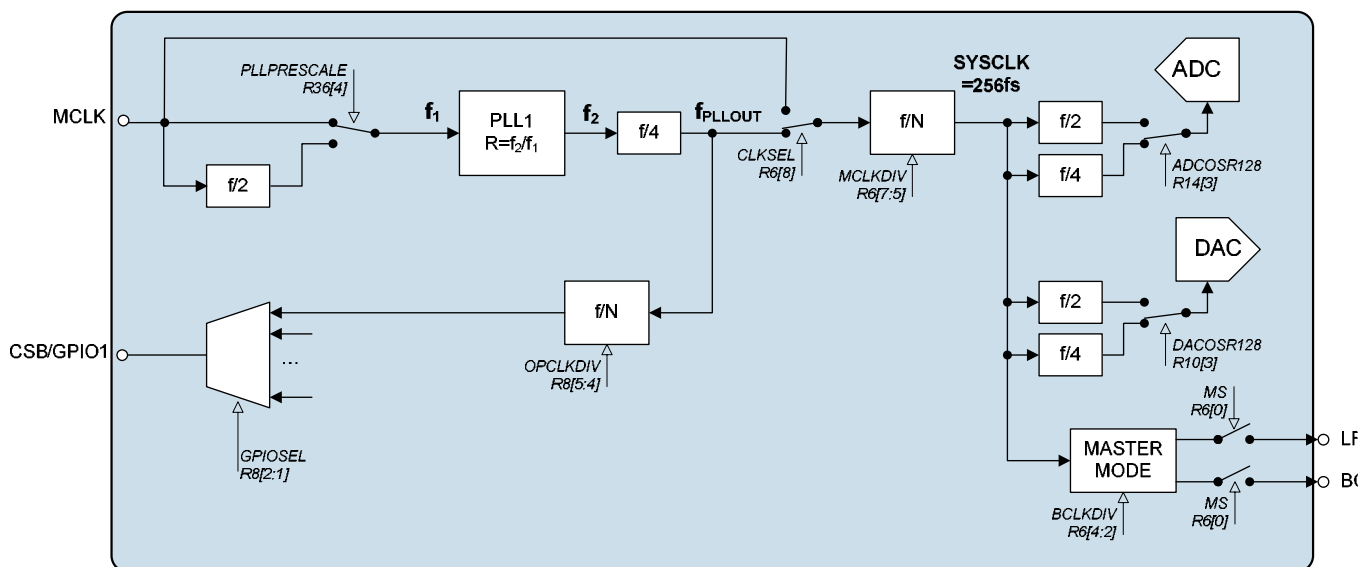


Figure 43 PLL and Clock Select Circuit

The PLL frequency ratio  $R = f_2/f_1$  (see Figure 43) can be set using the register bits PLLK and PLLN:

$$\text{PLLN} = \text{int } R$$

$$\text{PLLK} = \text{int } (2^{24} (R - \text{PLLN}))$$

**EXAMPLE:**

MCLK=12MHz, required clock = 12.288MHz.

R should be chosen to ensure  $5 < \text{PLLN} < 13$ . There is a fixed divide by 4 in the PLL and a selectable divide by N after the PLL which should be set to divide by 2 to meet this requirement.

Enabling the divide by 2 sets the required  $f_2 = 4 \times 2 \times 12.288\text{MHz} = 98.304\text{MHz}$ .

$$R = 98.304 / 12 = 8.192$$

$$\text{PLLN} = \text{int } R = 8$$

$$k = \text{int } (2^{24} \times (8.192 - 8)) = 3221225 = 3126\text{E9h}$$

REGISTER ADDRESS	BIT	LABEL	DEFAULT	DESCRIPTION
R36 PLL N value	4	PLLPRESCALE	0	0 = MCLK input not divided (default) 1 = Divide MCLK by 2 before input to PLL
	3:0	PLLN	1000	Integer (N) part of PLL input/output frequency ratio. Use values greater than 5 and less than 13.
R37 PLL K value 1	5:0	PLLK [23:18]	0Ch	Fractional (K) part of PLL1 input/output frequency ratio (treat as one 24-digit binary number).
R38 PLL K Value 2	8:0	PLLK [17:9]	093h	
R39 PLL K Value 3	8:0	PLLK [8:0]	0E9h	

Table 60 PLL Frequency Ratio Control

---

The PLL performs best when  $f_2$  is around 90MHz. Its stability peaks at N=8. Some example settings are shown in Table 61.

MCLK (MHZ) (F1)	DESIRED OUTPUT (MHZ)	F2 (MHZ)	PRESCALE DIVIDE	POSTSCALE DIVIDE	R	N (HEX)	K (HEX)
12	11.29	90.3168	1	2	7.5264	7	86C226
12	12.288	98.304	1	2	8.192	8	3126E8
13	11.29	90.3168	1	2	6.947446	6	F28BD4
13	12.288	98.304	1	2	7.561846	7	8FD525
14.4	11.29	90.3168	1	2	6.272	6	45A1CA
14.4	12.288	98.304	1	2	6.826667	6	D3A06E
19.2	11.29	90.3168	2	2	9.408	9	6872AF
19.2	12.288	98.304	2	2	10.24	A	3D70A3
19.68	11.29	90.3168	2	2	9.178537	9	2DB492
19.68	12.288	98.304	2	2	9.990243	9	FD809F
19.8	11.29	90.3168	2	2	9.122909	9	1F76F7
19.8	12.288	98.304	2	2	9.929697	9	EE009E
24	11.29	90.3168	2	2	7.5264	7	86C226
24	12.288	98.304	2	2	8.192	8	3126E8
26	11.29	90.3168	2	2	6.947446	6	F28BD4
26	12.288	98.304	2	2	7.561846	7	8FD525
27	11.29	90.3168	2	2	6.690133	6	BOAC93
27	12.288	98.304	2	2	7.281778	7	482296

Table 61 PLL Frequency Examples

### LOOPBACK

Setting the LOOPBACK register bit enables digital loopback. When this bit is set the output data from the ADC audio interface is fed directly into the DAC data input.

### COMPANDING

The WM8978 supports A-law and  $\mu$ -law and companding and linear mode on both transmit (ADC) and receive (DAC) sides. Companding can be enabled on the DAC or ADC audio interfaces by writing the appropriate value to the DAC\_COMP or ADC\_COMP register bits respectively.

REGISTER ADDRESS	BIT	LABEL	DEFAULT	DESCRIPTION
R5 Companding Control	0	LOOPBACK	0	Digital loopback function 0=No loopback 1=Loopback enabled, ADC data output is fed directly into DAC data input.
	2:1	ADC_COMP	0	ADC companding 00=off (linear mode) 01=reserved 10= $\mu$ -law 11=A-law
	4:3	DAC_COMP	0	DAC companding 00=off (linear mode) 01=reserved 10= $\mu$ -law 11=A-law
	5	WL8	0	0=off 1=device operates in 8-bit mode

**Table 62 Companding Control**

Companding involves using a piecewise linear approximation of the following equations (as set out by ITU-T G.711 standard) for data compression:

$\mu$ -law (where  $\mu=255$  for the U.S. and Japan):

$$F(x) = \ln(1 + \mu|x|) / \ln(1 + \mu) \quad -1 \leq x \leq 1$$

A-law (where  $A=87.6$  for Europe):

$$F(x) = A|x| / (1 + \ln A) \quad \text{for } x \leq 1/A$$

$$F(x) = (1 + \ln A|x|) / (1 + \ln A) \quad \text{for } 1/A \leq x \leq 1$$

The companded data is also inverted as recommended by the G.711 standard (all 8 bits are inverted for  $\mu$ -law, all even data bits are inverted for A-law). The data will be transmitted as the first 8 MSB's of data.

Companding converts 13 bits ( $\mu$ -law) or 12 bits (A-law) to 8 bits using non-linear quantization. The input data range is separated into 8 levels, allowing low amplitude signals better precision than that of high amplitude signals. This is to exploit the operation of the human auditory system, where louder sounds do not require as much resolution as quieter sounds. The companded signal is an 8-bit word containing sign (1-bit), exponent (3-bits) and mantissa (4-bits).

Setting the WL8 register bit allows the device to operate with 8-bit data. In this mode it is possible to use 8 BCLK's per LRC frame. When using DSP mode B, this allows 8-bit data words to be output consecutively every 8 BCLK's and can be used with 8-bit data words using the A-law and  $\mu$ -law companding functions.

BIT7	BIT[6:4]	BIT[3:0]
SIGN	EXPONENT	MANTISSA

**Table 63 8-bit Companded Word Composition**

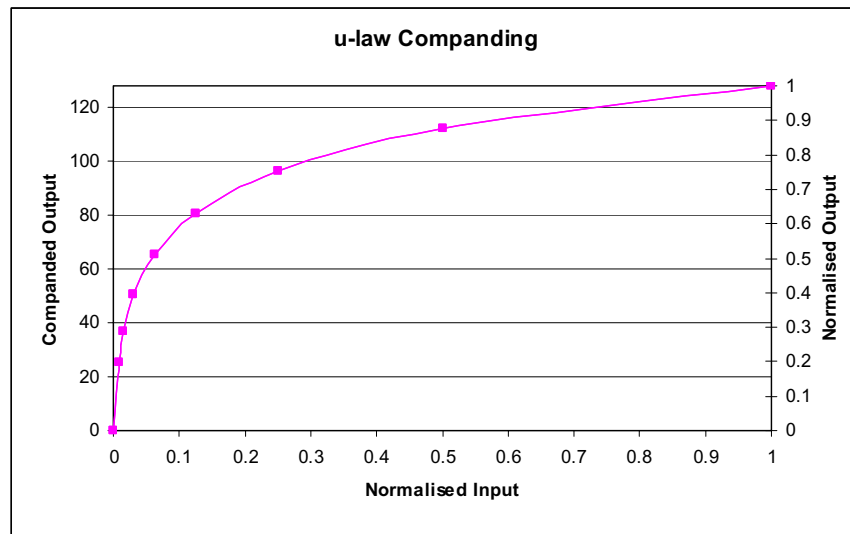


Figure 44 u-Law Comanding

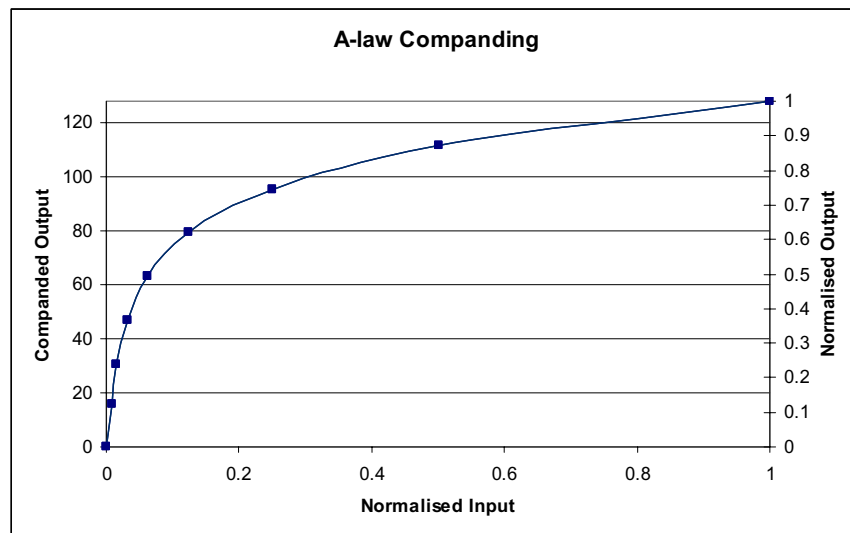


Figure 45 A-Law Comanding

## GENERAL PURPOSE INPUT/OUTPUT

The WM8978 has three dual purpose input/output pins.

- CSB/GPIO1: CSB / GPIO pin
- L2/GPIO2: Left channel line input / headphone detection input
- R2/GPIO3: Right channel line input / headphone detection input

The GPIO2 and GPIO3 functions are provided for use as jack detection inputs.

The GPIO1 function is provided for use as a jack detection input or a general purpose output.

The default configuration for the CSB/GPIO1 pin is to be an input.

When setup as an input, the CSB/GPIO1 pin can either be used as CSB or for jack detection, depending on how the MODE pin is set.

Table 49 illustrates the functionality of the GPIO1 pin when used as a general purpose output.

REGISTER ADDRESS	BIT	LABEL	DEFAULT	DESCRIPTION
R8 GPIO Control	2:0	GPIO1SEL	000	CSB/GPIO1 pin function select: 000= input (CSB/jack detection: depending on MODE setting) 001= reserved 010=Temp ok 011=Amute active 100=PLL clk o/p 101=PLL lock 110=logic 0 111=logic 1
	3	GPIO1POL	0	GPIO1 Polarity invert 0=Non inverted 1=Inverted
	5:4	OPCLKDIV	00	PLL Output clock division ratio 00=divide by 1 01=divide by 2 10=divide by 3 11=divide by 4

**Table 64 CSB/GPIO Control**

Note: If MODE is set to 3 wire mode, CSB/GPIO1 shall be used as CSB input irrespective of the GPIO1SEL[2:] bits.

Note that SLOWCLKEN must be enabled when using the Jack Detect function.

For further details of the Jack detect operation see the OUTPUT SWITCHING section.

## OUTPUT SWITCHING (JACK DETECT)

When the device is operated using a 2-wire interface the CSB/GPIO1 pin can be used as a switch control input to automatically disable one set of outputs and enable another the most common use for this functionality is as jack detect circuitry. The L2/GPIO2 and R2/GPIO3 pins can also be used for this purpose.

The GPIO pins have an internal de-bounce circuit when in this mode in order to prevent the output enables from toggling multiple times due to input glitches. This de-bounce circuit is clocked from a slow clock with period  $2^{21} \times \text{MCLK}$  and is enabled by the SLOWCLKEN bit.

Notes:

1. The SLOWCLKEN bit must be enabled for the jack detect circuitry to operate.
2. The GPIOPOL bit is not relevant for jack detection, it is the signal detected at the pin which is used

Switching on/off of the outputs is fully configurable by the user. Each output, OUT1, OUT2, OUT3 and OUT4 has 2 associated enables. OUT1\_EN\_0, OUT2\_EN\_0, OUT3\_EN\_0 and OUT4\_EN\_0 are the output enable signals which are used if the selected jack detection pin is at logic 0 (after de-bounce). OUT1\_EN\_1, OUT2\_EN\_1, OUT3\_EN\_1 and OUT4\_EN\_1 are the output enable signals which are used if the selected jack detection pin is at logic 1 (after de-bounce).

The jack detection enables operate as follows:

All OUT\_EN signals have an AND function performed with their normal enable signals (in Table 52). When an output is normally enabled at per Table 54, the selected jack detection enable (controlled by selected jack detection pin polarity) is set 0; it will turn the output off. If the normal enable signal is already OFF (0), the jack detection signal will have no effect due to the AND function.

During jack detection if the user desires an output to be un-changed whether the jack is in or not, both the JD\_EN settings i.e. JD\_EN0 and JD\_EN1, should be set to 0000.

The VMID\_EN signal has an OR function performed with the normal VMID driver enable. If the VMID\_EN signal is to have no effect to normal functionality when jack detection is enabled, it should be set to 0 for all JD\_EN0 or JD\_EN1 settings.

If jack detection is not enabled (JD\_EN=0), the output enables default to all 1's, allowing the outputs to be controlled as normal via the normal output enables found in Table 52.

REGISTER ADDRESS	BIT	LABEL	DEFAULT	DESCRIPTION
R9 GPIO control	5:4	JD_SEL	00	Pin selected as jack detection input 00 = GPIO1 01 = GPIO2 10 = GPIO3 11 = Reserved
	6	JD_EN	0	Jack Detection Enable 0 = disabled 1 = enabled
	8:7	JD_VMID	00	[7] VMID_EN_0 [8] VMID_EN_1
R13	3:0	JD_EN0	0000	Output enables when selected jack detection input is logic 0. [0]= OUT1_EN_0 [1]= OUT2_EN_0 [2]= OUT3_EN_0 [3]= OUT4_EN_0
	7:4	JD_EN1	0000	Output enables when selected jack detection input is logic 1 0000-0011 = Reserved [4]= OUT1_EN_1 [5]= OUT2_EN_1 [6]= OUT3_EN_1 [7]= OUT4_EN_1

**Table 65 Jack Detect Register Control Bits**

## CONTROL INTERFACE

### SELECTION OF CONTROL MODE AND 2-WIRE MODE ADDRESS

The control interface can operate as either a 3-wire or 2-wire MPU interface. The MODE pin determines the 2 or 3 wire mode as shown in Table 66.

The WM8978 is controlled by writing to registers through a serial control interface. A control word consists of 16 bits. The first 7 bits (B15 to B9) are address bits that select which control register is accessed. The remaining 9 bits (B8 to B0) are register bits, corresponding to the 9 bits in each control register.

MODE	INTERFACE FORMAT
Low	2 wire
High	3 wire

Table 66 Control Interface Mode Selection

### 3-WIRE SERIAL CONTROL MODE

In 3-wire mode, every rising edge of SCLK clocks in one data bit from the SDIN pin. A rising edge on CSB/GPIO1 pin latches in a complete control word consisting of the last 16 bits.

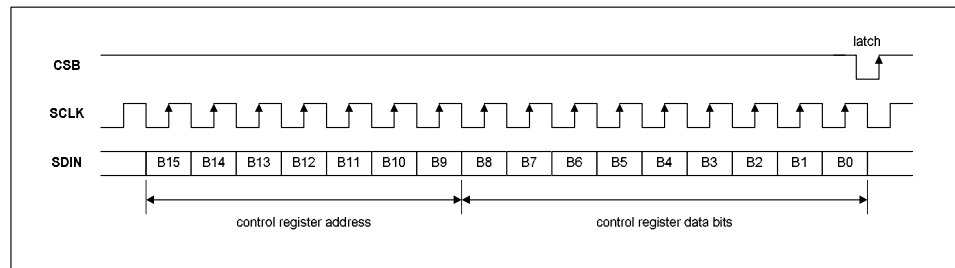


Figure 46 3-Wire Serial Control Interface

### 2-WIRE SERIAL CONTROL MODE

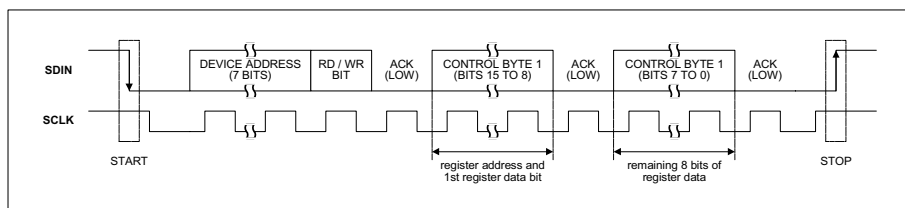
The WM8978 supports software control via a 2-wire serial bus. Many devices can be controlled by the same bus, and each device has a unique 7-bit device address (this is not the same as the 7-bit address of each register in the WM8978).

The WM8978 operates as a slave 2-wire device only. The controller indicates the start of data transfer with a high to low transition on SDIN while SCLK remains high. This indicates that a device address and data will follow. All devices on the 2-wire bus respond to the start condition and shift in the next eight bits on SDIN (7-bit address + Read/Write bit, MSB first). If the device address received matches the address of the WM8978, then the WM8978 responds by pulling SDIN low on the next clock pulse (ACK). If the address is not recognised or the R/W bit is '1' when operating in write only mode, the WM8978 returns to the idle condition and wait for a new start condition and valid address.

During a write, once the WM8978 has acknowledged a correct address, the controller sends the first byte of control data (B15 to B8, i.e. the WM8978 register address plus the first bit of register data). The WM8978 then acknowledges the first data byte by pulling SDIN low for one clock pulse. The controller then sends the second byte of control data (B7 to B0, i.e. the remaining 8 bits of register data), and the WM8978 acknowledges again by pulling SDIN low.

Transfers are complete when there is a low to high transition on SDIN while SCLK is high. After a complete sequence the WM8978 returns to the idle state and waits for another start condition. If a start or stop condition is detected out of sequence at any point during data transfer (i.e. SDIN changes while SCLK is high), the device jumps to the idle condition.





**Figure 47 2-Wire Serial Control Interface**

In 2-wire mode the WM8978 has a fixed device address, 0011010.

## RESETTING THE CHIP

The WM8978 can be reset by performing a write of any value to the software reset register (address 0 hex). This will cause all register values to be reset to their default values. In addition to this there is a Power-On Reset (POR) circuit which ensures that the registers are set to default when the device is powered up.

## POWER SUPPLIES

The WM8978 can use up to five separate power supplies:

**AVDD and AGND:** Analogue supply, powers all analogue functions except the speaker output and mono output drivers. AVDD can range from 2.5V to 3.6V and has the most significant impact on overall power consumption (except for power consumed in the headphone). A large AVDD slightly improves audio quality.

**SPKVDD and SPKGND:** Headphone and Speaker supplies, power the speaker and mono output drivers. SPKVDD can range from 2.5V to 5V. SPKVDD can be tied to AVDD, but it requires separate layout and decoupling capacitors to curb harmonic distortion. With a larger SPKVDD, louder headphone and speaker outputs can be achieved with lower distortion. If SPKVDD is lower than AVDD, the output signal may be clipped.

**DCVDD:** Digital core supply, powers all digital functions except the audio and control interfaces. DCVDD can range from 1.71V to 3.6V, and has no effect on audio quality. The return path for DCVDD is DGND, which is shared with DBVDD.

DBVDD can range from 1.71V to 3.6V. DBVDD return path is through DGND.

It is possible to use the same supply voltage for all four supplies. However, digital and analogue supplies should be routed and decoupled separately on the PCB to keep digital switching noise out of the analogue signal paths.

DCVDD should be greater than or equal to 1.9V when using the PLL.

## RECOMMENDED POWER UP/DOWN SEQUENCE

In order to minimise output 'pop' and 'click' noise it is recommended that the device is powered up in a controlled sequence.

In addition to this it is recommended that the zero cross functions are used when changing the volume in the PGAs.

## POWER MANAGEMENT

### SAVING POWER BY REDUCING OVERSAMPLING RATE

The default mode of operation of the ADC and DAC digital filters is in 64x oversampling mode. Under the control of ADCOSR and DACOSR the oversampling rate may be doubled. 64x oversampling results in a slight decrease in noise performance compared to 128x but lowers the power consumption of the device.

REGISTER ADDRESS	BIT	LABEL	DEFAULT	DESCRIPTION
R10 DAC control	3	DACOSR128	0	DAC oversample rate select 0 = 64x (lowest power) 1 = 128x (best SNR)
R14 ADC control	3	ADCOSR128	0	ADC oversample rate select 0 = 64x (lowest power) 1 = 128x (best SNR)

Table 67 ADC and DAC Oversampling Rate Selection

### VMID

The analogue circuitry will not work when VMID is disabled (VMIDSEL[1:0] = 00b). The impedance of the VMID resistor string, together with the decoupling capacitor on the VMID pin will determine the startup time of the VMID circuit.

REGISTER ADDRESS	BIT	LABEL	DEFAULT	DESCRIPTION
R1 Power management 1	1:0	VMIDSEL	00	Reference string impedance to VMID pin (determines startup time): 00=off (open circuit) 01=75kΩ 10=300kΩ 11=5kΩ (for fastest startup)

Table 68 VMID Impedance Control

### BIASEN

The analogue amplifiers will not operate unless BIASEN is enabled.

REGISTER ADDRESS	BIT	LABEL	DEFAULT	DESCRIPTION
R1 Power management 1	3	BIASEN	0	Analogue amplifier bias control 0=disabled 1=enabled

Table 69 Analogue Bias Control

## REGISTER MAP

ADDR B[15:9]	REGISTER NAME	B8	B7	B6	B5	B4	B3	B2	B1	B0	DEF'T VAL (HEX)	
DEC	HEX											
0	00	Software Reset										
1	01	Power manage1	BUFDCOP EN	OUT4MIX EN	OUT3MIX EN	PLEN	MICBEN	BIASEN	BUFIOEN	VMIDSEL		000
2	02	Power manage2	ROUT1EN	LOUT1EN	SLEEP	BOOST ENR	BOOST ENL	INPPGA ENR	INPPGA ENL	ADCENR	ADCENL	000
3	03	Power manage3	OUT4EN	OUT3EN	LOUT2EN	ROUT2EN	0	RMIXEN	LMIXEN	DACENR	DACENL	000
4	04	Audio Interface	BCP	LRP	WL		FMT		DAC LRSWAP	ADC LRSWAP	MONO	050
5	05	Comanding ctrl	0	0	0	WL8	DAC_COMP		ADC_COMP		LOOPBACK	000
6	06	Clock Gen ctrl	CLKSEL	MCLKDIV			BCLKDIV			0	MS	140
7	07	Additional ctrl	0	0	0	0	0	SR			LOWCLKEN	000
8	08	GPIO	0	0	0	OPCLKDIV		GPIO1POL	GPIO1SEL[2:0]			000
9	09	Jack detect control	JD_VMID		JD_EN	JD_SEL		0	0	0	0	000
10	0A	DAC Control	0	0	SOFT MUTE	0	0	DACOSR 128	AMUTE	DACPOLR	DACPOLL	000
11	0B	Left DAC digital Vol	DACVU	DACVOLL								OFF
12	0C	Right DAC dig1 Vol	DACVU	DACVOLR								OFF
13	0D	ack Detect Control	JD_EN1				JD_EN0				000	
14	0E	ADC Control	HPFEN	HPFAPP	HPFCUT			DACOSR 128	0	ADCRPOL	ADCLPOL	100
15	0F	Left ADC Digital Vol	DACVU	ADCVOLL								OFF
16	10	Right ADC Digital Vol	DACVU	ADCVOLR								OFF
18	12	EQ1 – low shelf	EQ3DMODE	0	EQ1C		EQ1G				12C	
19	13	EQ2 – peak 1	EQ2BW	0	EQ2C		EQ2G				02C	
20	14	EQ3 – peak 2	EQ3BW	0	EQ3C		EQ3G				02C	
21	15	EQ4 – peak 3	EQ4BW	0	EQ4C		EQ4G				02C	
22	16	EQ5 – high shelf	0	0	EQ5C		EQ5G				02C	
24	18	DAC Limiter 1	LIMEN	LIMDCY				LIMATK				032
25	19	DAC Limiter 2	0	0	LIMLVL			LIMBOOST				000
27	1B	Notch Filter 1	NFU	NFEN	NFA0[13:7]							000
28	1C	Notch Filter 2	NFU	0	NFA0[6:0]							000
29	1D	Notch Filter 3	NFU	0	NFA1[13:7]							000
30	1E	Notch Filter 4	NFU	0	NFA1[6:0]							000
32	20	ALC control 1	ALCSEL		0	ALCMAXGAIN			ALCMINGAIN			038
33	21	ALC control 2	0	ALCHLD				ALCLVL				00B
34	22	ALC control 3	ALCMODE	ALCDCY				ALCATK				032
35	23	Noise Gate	0	0	0	0	0	NGEN	NGTH			000
36	24	PLL N	0	0	0	0	PLLPRE SCALE	PLLN[3:0]				008
37	25	PLL K 1	0	0	0	PLLK[23:18]						00C
38	26	PLL K 2	PLLK[17:9]									093
39	27	PLL K 3	PLLK[8:0]									0E9
41	29	3D control	0	0	0	0	0	DEPTH3D				000
43	2B	Beep control	0	0	0	MUTER PGA2INV	INVROUT2	BEEPVOL			BEEPEN	000
44	2C	Input ctrl	MBVSEL	0	R2_2 INPPGA	RIN2 INPPGA	RIP2 INPPGA	0	L2_2 INPPGA	LIN2 INPPGA	LIP2 INPPGA	033
45	2D	Left INP PGA gain ctrl	INPPGA UPDATE	NPPGAZCL	INPPGA MUTEL	INPPGAVOLL						010

ADDR B[15:9]		REGISTER NAME	B8	B7	B6	B5	B4	B3	B2	B1	B0	DEF'T VAL (HEX)	
DEC	HEX												
46	2E	Right INP PGA gain ctrl	INPGA UPDATE	NPPGAZCR	INPPGA MUTER	INPPGAVOLR						010	
47	2F	Left ADC Boost ctrl	PGABOOSTL	0	L2_2BOOSTVOL			0	AUXL2BOOSTVOL				100
48	30	Right ADC Boost ctrl	PGABOOSTR	0	R2_2BOOSTVOL			0	AUXR2BOOSTVOL				100
49	31	Output ctrl	0	0	DACL2 RMIX	DACR2 LMIX	OUT4 BOOST	OUT3 BOOST	SPK BOOST	TSDEN	VROI	002	
50	32	Left mixer ctrl	AUXLMIXVOL			AUXL2LMIX	BYPLMIXVOL			BYPL2LMIX	DACL2LMIX	001	
51	33	Right mixer ctrl	AUXRMIXVOL			UXR2RMIX	BYPRMIXVOL			BYPR2RMIX	DACR2RMIX	001	
52	34	LOUT1 (HP) volume ctrl	HPVU	LOUT1ZC	LOUT1 MUTE	LOUT1VOL						039	
53	35	ROUT1 (HP) volume ctrl	HPVU	ROUT1ZC	ROUT1 MUTE	ROUT1VOL						039	
54	36	LOUT2 (SPK) volume ctrl	SPKVU	LOUT2ZC	LOUT2 MUTE	LOUT2VOL						039	
55	37	ROUT2 (SPK) volume ctrl	SPKVU	ROUT2ZC	ROUT2 MUTE	ROUT2VOL						039	
56	38	OUT3 mixer ctrl	0	0	OUT3 MUTE	0	0	OUT4_ 2OUT3	BYPL2 OUT3	LMIX2 OUT3	LDAC2 OUT3	001	
57	39	OUT4 (MONO) mixer ctrl	0	0	OUT4 MUTE	HALFSIG	LMIX2 OUT4	LDAC2 OUT4	BYPR2 OUT4	RMIX2 OUT4	RDAC2 OUT4	001	

Table 70 WM8978 Register Map

## REGISTER BITS BY ADDRESS

### Notes:

1. Default values of N/A indicate non-latched data bits (e.g. software reset or volume update bits).
2. Register bits marked as "Reserved" should not be changed from the default.

REGISTER ADDRESS	BIT	LABEL	DEFAULT	DESCRIPTION	REFER TO
0 (00h)	[8:0]	RESET	N/A	Software reset	Resetting the Chip
1 (01h)	8	BUFDCOPEN	0	Dedicated buffer for DC level shifting output stages when in 1.5x gain boost configuration. 0=Buffer disabled 1=Buffer enabled (required for 1.5x gain boost)	Analogue Outputs
	7	OUT4MIXEN	0	OUT4 mixer enable 0=disabled 1=enabled	Power Management
	6	OUT3MIXEN	0	OUT3 mixer enable 0=disabled 1=enabled	Power Management
	5	PLLEN	0	PLL enable 0=PLL off 1=PLL on	Master Clock and Phase Locked Loop (PLL)
	4	MICBEN	0	Microphone Bias Enable 0 = OFF (high impedance output) 1 = ON	Input Signal Path
	3	BIASEN	0	Analogue amplifier bias control 0=disabled 1=enabled	Power Management
	2	BUFIOEN	0	Unused input/output tie off buffer enable 0=disabled 1=enabled	Power Management
	1:0	VMIDSEL	00	Reference string impedance to VMID pin 00=off (open circuit) 01=75kΩ 10=300kΩ 11=5kΩ	Power Management
2 (02h)	8	ROUT1EN	0	ROUT1 output enable 0=disabled 1=enabled	Power Management
	7	LOUT1EN	0	LOUT1 output enable 0=disabled 1=enabled	Power Management
	6	SLEEP	0	0 = normal device operation 1 = residual current reduced in device standby mode	Power Management
	5	BOOSTENR	0	Right channel Input BOOST enable 0 = Boost stage OFF 1 = Boost stage ON	Power Management
	4	BOOSTENL	0	Left channel Input BOOST enable 0 = Boost stage OFF 1 = Boost stage ON	Power Management
	3	INPPGAENR	0	Right channel input PGA enable 0 = disabled 1 = enabled	Power Management

REGISTER ADDRESS	BIT	LABEL	DEFAULT	DESCRIPTION	REFER TO
	2	INPPGAENL	0	Left channel input PGA enable 0 = disabled 1 = enabled	Power Management
	1	ADCENR	0	Enable ADC right channel: 0 = ADC disabled 1 = ADC enabled	Analogue to Digital Converter (ADC)
	0	ADCENL	0	Enable ADC left channel: 0 = ADC disabled 1 = ADC enabled	Analogue to Digital Converter (ADC)
3 (03h)	8	OUT4EN	0	OUT4 enable 0 = disabled 1 = enabled	Power Management
	7	OUT3EN	0	OUT3 enable 0 = disabled 1 = enabled	Power Management
	6	LOUT2EN	0	LOUT2 enable 0 = disabled 1 = enabled	Power Management
	5	ROUT2EN	0	ROUT2 enable 0 = disabled 1 = enabled	Power Management
	3	RMIXEN	0	Right output channel mixer enable: 0 = disabled 1 = enabled	Analogue Outputs
	2	LMIXEN	0	Left output channel mixer enable: 0 = disabled 1 = enabled	Analogue Outputs
	1	DACENR	0	Right channel DAC enable 0 = DAC disabled 1 = DAC enabled	Analogue Outputs
	0	DACENL	0	Left channel DAC enable 0 = DAC disabled 1 = DAC enabled	Analogue Outputs
4 (04h)	8	BCP	0	BCLK polarity 0=normal 1=inverted	Digital Audio Interfaces
	7	LRP	0	LRC clock polarity 0=normal 1=inverted	Digital Audio Interfaces
	6:5	WL	10	Word length 00=16 bits 01=20 bits 10=24 bits 11=32 bits	Digital Audio Interfaces
	4:3	FMT	10	Audio interface Data Format Select: 00=Right Justified 01=Left Justified 10= $i^2S$ format 11= DSP/PCM mode	Digital Audio Interfaces

REGISTER ADDRESS	BIT	LABEL	DEFAULT	DESCRIPTION	REFER TO
	2	DACLRSWAP	0	Controls whether DAC data appears in 'right' or 'left' phases of LRC clock: 0=DAC data appear in 'left' phase of LRC 1=DAC data appears in 'right' phase of LRC	Digital Audio Interfaces
	1	ADCLRSWAP	0	Controls whether ADC data appears in 'right' or 'left' phases of LRC clock: 0=ADC data appear in 'left' phase of LRC 1=ADC data appears in 'right' phase of LRC	Digital Audio Interfaces
	0	MONO	0	Selects between stereo and mono device operation: 0=Stereo device operation 1=Mono device operation. Data appears in 'left' phase of LRC	Digital Audio Interfaces
5 (05h)	8:6		000	Reserved	
	5	WL8	0	Companding Control 8-bit mode 0=off 1=device operates in 8-bit mode	Digital Audio Interfaces
	4:3	DAC_COMP	00	DAC companding 00=off (linear mode) 01=reserved 10= $\mu$ -law 11=A-law	Digital Audio Interfaces
	2:1	ADC_COMP	00	ADC companding 00=off (linear mode) 01=reserved 10= $\mu$ -law 11=A-law	Digital Audio Interfaces
	0	LOOPBACK	0	Digital loopback function 0=No loopback 1=Loopback enabled, ADC data output is fed directly into DAC data input.	Digital Audio Interfaces
6 (06h)	8	CLKSEL	1	Controls the source of the clock for all internal operation: 0=MCLK 1=PLL output	Digital Audio Interfaces
	7:5	MCLKDIV	010	Sets the scaling for either the MCLK or PLL clock output (under control of CLKSEL) 000=divide by 1 001=divide by 1.5 010=divide by 2 011=divide by 3 100=divide by 4 101=divide by 6 110=divide by 8 111=divide by 12	Digital Audio Interfaces

REGISTER ADDRESS	BIT	LABEL	DEFAULT	DESCRIPTION	REFER TO
	4:2	BCLKDIV	000	Configures the BCLK output frequency, for use when the chip is master over BCLK. 000=divide by 1 (BCLK=MCLK) 001=divide by 2 (BCLK=MCLK/2) 010=divide by 4 011=divide by 8 100=divide by 16 101=divide by 32 110=reserved 111=reserved	Digital Audio Interfaces
	1		0	Reserved	
	0	MS	0	Sets the chip to be master over LRC and BCLK 0=BCLK and LRC clock are inputs 1=BCLK and LRC clock are outputs generated by the WM8978 (MASTER)	Digital Audio Interfaces
7 (07h)	8:4		00000	Reserved	
	3:1	SR	000	Approximate sample rate (configures the coefficients for the internal digital filters): 000=48kHz 001=32kHz 010=24kHz 011=16kHz 100=12kHz 101=8kHz 110-111=reserved	Audio Sample Rates
	0	SLOWCLKEN	0	Slow clock enable. Used for both the jack insert detect debounce circuit and the zero cross timeout. 0 = slow clock disabled 1 = slow clock enabled	Analogue Outputs
8 (08h)	8:6		000	Reserved	
	5:4	OPCLKDIV	00	PLL Output clock division ratio 00=divide by 1 01=divide by 2 10=divide by 3 11=divide by 4	General Purpose Input/Output (GPIO)
	3	GPIO1POL	0	GPIO1 Polarity invert 0=Non inverted 1=Inverted	General Purpose Input/Output (GPIO)
	2:0	GPIO1SEL [2:0]	000	CSB/GPIO1 pin function select: 000= input (CSB/jack detection: depending on MODE setting) 001= reserved 010=Temp ok 011=Amute active 100=PLL clk o/p 101=PLL lock 110=logic 1 111=logic 0	General Purpose Input/Output (GPIO)



REGISTER ADDRESS	BIT	LABEL	DEFAULT	DESCRIPTION	REFER TO
9 (09h)	8:7	JD_VMID	00	[7] VMID_EN_0 [8] VMID_EN_1	Output Switching (Jack Detect)
	6	JD_EN	0	Jack Detection Enable 0=disabled 1=enabled	Output Switching (Jack Detect)
	5:4	JD_SEL	00	Pin selected as jack detection input 00 = GPIO1 01 = GPIO2 10 = GPIO3 11 = Reserved	Output Switching (Jack Detect)
10 (0Ah)	8:7		00	Reserved	
	6	SOFTMUTE	0	Softmute enable: 0=Disabled 1=Enabled	Output Signal Path
	5:4		00	Reserved	
	3	DACOSR128	0	DAC oversample rate select 0 = 64x (lowest power) 1 = 128x (best SNR)	Power Management
	2	AMUTE	0	Automute enable 0 = Amute disabled 1 = Amute enabled	Output Signal Path
	1	DACPOLR	0	Right DAC output polarity: 0 = non-inverted 1 = inverted (180 degrees phase shift)	Output Signal Path
	0	DACPOLL	0	Left DAC output polarity: 0 = non-inverted 1 = inverted (180 degrees phase shift)	Output Signal Path
11 (0Bh)	8	DACVU	N/A	DAC left and DAC right volume do not update until a 1 is written to DACVU (in reg 11 or 12)	Digital to Analogue Converter (DAC)
	7:0	DACVOLL	11111111	Left DAC Digital Volume Control 0000 0000 = Digital Mute 0000 0001 = -127dB 0000 0010 = -126.5dB ... 0.5dB steps up to 1111 1111 = 0dB	Digital to Analogue Converter (DAC)
12 (0Ch)	8	DACVU	N/A	DAC left and DAC right volume do not update until a 1 is written to DACVU (in reg 11 or 12)	Output Signal Path
	7:0	DACVOLR	11111111	Right DAC Digital Volume Control 0000 0000 = Digital Mute 0000 0001 = -127dB 0000 0010 = -126.5dB ... 0.5dB steps up to 1111 1111 = 0dB	Output Signal Path

REGISTER ADDRESS	BIT	LABEL	DEFAULT	DESCRIPTION	REFER TO
13 (0Dh)	8		0	Reserved	
	7:4	JD_EN1	0000	Output enabled when selected jack detection input is logic 1 [4]= OUT1_EN_1 [5]= OUT2_EN_1 [6]= OUT3_EN_1 [7]= OUT4_EN_1	Output Switching (Jack Detect)
	3:0	JD_EN0	0000	Output enabled when selected jack detection input is logic 0. [0]= OUT1_EN_0 [1]= OUT2_EN_0 [2]= OUT3_EN_0 [3]= OUT4_EN_0	Output Switching (Jack Detect)
14 (0Eh)	8	HPFEN	1	High Pass Filter Enable 0=disabled 1=enabled	Analogue to Digital Converter (ADC)
	7	HPFAPP	0	Select audio mode or application mode 0=Audio mode (1 <sup>st</sup> order, fc = ~3.7Hz) 1=Application mode (2 <sup>nd</sup> order, fc = HPFCUT)	Analogue to Digital Converter (ADC)
	6:4	HPFCUT	000	Application mode cut-off frequency See Table 17 for details.	Analogue to Digital Converter (ADC)
	3	ADCOSR 128	0	ADC oversample rate select 0 = 64x (lowest power) 1 = 128x (best SNR)	Power Management
	2		0	Reserved	
	1	ADCRPOL	0	ADC right channel polarity adjust: 0=normal 1=inverted	Analogue to Digital Converter (ADC)
	0	ADCLPOL	0	ADC left channel polarity adjust: 0=normal 1=inverted	Analogue to Digital Converter (ADC)
15 (0Fh)	8	ADCVU	N/A	ADC left and ADC right volume do not update until a 1 is written to ADCVU (in reg 16 or 17)	Analogue to Digital Converter (ADC)
	7:0	ADCVOLL	11111111	Left ADC Digital Volume Control 0000 0000 = Digital Mute 0000 0001 = -127dB 0000 0010 = -126.5dB ... 0.5dB steps up to 1111 1111 = 0dB	Analogue to Digital Converter (ADC)
16 (10h)	8	ADCVU	N/A	ADC left and ADC right volume do not update until a 1 is written to ADCVU (in reg 16 or 17)	Analogue to Digital Converter (ADC)
	7:0	ADCVOLR	11111111	Right ADC Digital Volume Control 0000 0000 = Digital Mute 0000 0001 = -127dB 0000 0010 = -126.5dB ... 0.5dB steps up to 1111 1111 = 0dB	Analogue to Digital Converter (ADC)

REGISTER ADDRESS	BIT	LABEL	DEFAULT	DESCRIPTION	REFER TO
18 (12h)	8	EQ3DMODE	1	0 = Equaliser and 3D Enhancement applied to ADC path 1 = Equaliser and 3D Enhancement applied to DAC path	Output Signal Path
	7		0	Reserved	
	6:5	EQ1C		EQ Band 1 Cut-off Frequency: 00=80Hz 01=105Hz 10=135Hz 11=175Hz	Output Signal Path
	4:0	EQ1G	01100	EQ Band 1 Gain Control. See Table 39 for details.	Output Signal Path
19 (13h)	8	EQ2BW	0	EQ Band 2 Bandwidth Control 0=narrow bandwidth 1=wide bandwidth	Output Signal Path
	7		0	Reserved	Output Signal Path
	6:5	EQ2C	01	EQ Band 2 Centre Frequency: 00=230Hz 01=300Hz 10=385Hz 11=500Hz	Output Signal Path
	4:0	EQ2G	01100	EQ Band 2 Gain Control. See Table 39 for details.	Output Signal Path
20 (14h)	8	EQ3BW	0	EQ Band 3 Bandwidth Control 0=narrow bandwidth 1=wide bandwidth	Output Signal Path
	7		0	Reserved	Output Signal Path
	6:5	EQ3C	01	EQ Band 3 Centre Frequency: 00=650Hz 01=850Hz 10=1.1kHz 11=1.4kHz	Output Signal Path
	4:0	EQ3G	01100	EQ Band 3 Gain Control. See Table 39 for details.	Output Signal Path
21 (15h)	8	EQ4BW	0	EQ Band 4 Bandwidth Control 0=narrow bandwidth 1=wide bandwidth	Output Signal Path
	7		0	Reserved	Output Signal Path
	6:5	EQ4C	01	EQ Band 4 Centre Frequency: 00=1.8kHz 01=2.4kHz 10=3.2kHz 11=4.1kHz	Output Signal Path
	4:0	EQ4G	01100	EQ Band 4 Gain Control. See Table 39 for details.	Output Signal Path
22 (16h)	8:7		0	Reserved	Output Signal Path
	6:5	EQ5C	01	EQ Band 5 Cut-off Frequency: 00=5.3kHz 01=6.9kHz 10=9kHz 11=11.7kHz	Output Signal Path

REGISTER ADDRESS	BIT	LABEL	DEFAULT	DESCRIPTION	REFER TO
	4:0	EQ5G	01100	EQ Band 5 Gain Control. See Table 39 for details.	Output Signal Path
24 (18h)	8	LIMEN	0	Enable the DAC digital limiter: 0=disabled 1=enabled	Output Signal Path
	7:4	LIMDCY	0011	DAC Limiter Decay time (per 6dB gain change) for 44.1kHz sampling. Note that these will scale with sample rate: 0000=750us 0001=1.5ms 0010=3ms 0011=6ms 0100=12ms 0101=24ms 0110=48ms 0111=96ms 1000=192ms 1001=384ms 1010=768ms	Output Signal Path
	3:0	LIMATK	0010	DAC Limiter Attack time (per 6dB gain change) for 44.1kHz sampling. Note that these will scale with sample rate. 0000=94us 0001=188s 0010=375us 0011=750us 0100=1.5ms 0101=3ms 0110=6ms 0111=12ms 1000=24ms 1001=48ms 1010=96ms 1011 to 1111=192ms	Output Signal Path
25 (19h)	8:7		00	Reserved	
	6:4	LIMLVL	000	Programmable signal threshold level (determines level at which the DAC limiter starts to operate) 000=-1dB 001=-2dB 010=-3dB 011=-4dB 100=-5dB 101 to 111=-6dB	Output Signal Path
	3:0	LIMBOOST	0000	DAC Limiter volume boost (can be used as a stand alone volume boost when LIMEN=0): 0000=0dB 0001=+1dB 0010=+2dB ... (1dB steps) 1011=+11dB 1100=+12dB 1101 to 1111=reserved	Output Signal Path

REGISTER ADDRESS	BIT	LABEL	DEFAULT	DESCRIPTION	REFER TO
27 (1Bh)	8	NFU	0	Notch filter update. The notch filter values used internally only update when one of the NFU bits is set high.	Analogue to Digital Converter (ADC)
	7	NFEN	0	Notch filter enable: 0=Disabled 1=Enabled	Analogue to Digital Converter (ADC)
	6:0	NFA0[13:7]	0000000	Notch Filter a0 coefficient, bits [13:7]	Analogue to Digital Converter (ADC)
28 (1Ch)	8	NFU	0	Notch filter update. The notch filter values used internally only update when one of the NFU bits is set high.	Analogue to Digital Converter (ADC)
	7		0	Reserved	
	6:0	NFA0[6:0]	0000000	Notch Filter a0 coefficient, bits [6:0]	Analogue to Digital Converter (ADC)
29 (1Dh)	8	NFU	0	Notch filter update. The notch filter values used internally only update when one of the NFU bits is set high.	Analogue to Digital Converter (ADC)
	7		0	Reserved	
	6:0	NFA1[13:7]	0000000	Notch Filter a1 coefficient, bits [13:7]	Analogue to Digital Converter (ADC)
30 (1Eh)	8	NFU	0	Notch filter update. The notch filter values used internally only update when one of the NFU bits is set high.	Analogue to Digital Converter (ADC)
	7		0	Reserved	
	6:0	NFA1[6:0]	0000000	Notch Filter a1 coefficient, bits [6:0]	Analogue to Digital Converter (ADC)
32 (20h)	8:7	ALCSEL	00	ALC function select: 00=ALC off 01=ALC right only 10=ALC left only 11=ALC both on	Input Limiter/ Automatic Level Control (ALC)
	6		0	Reserved	
	5:3	ALCMAXGAIN	111	Set Maximum Gain of PGA 111=+35.25dB 110=+29.25dB 101=+23.25dB 100=+17.25dB 011=+11.25dB 010=+5.25dB 001=-0.75dB 000=-6.75dB	Input Limiter/ Automatic Level Control (ALC)

REGISTER ADDRESS	BIT	LABEL	DEFAULT	DESCRIPTION	REFER TO		
	2:0	ALCMINGAIN	000	Set minimum gain of PGA 000=-12dB 001=-6dB 010=0dB 011=+6dB 100=+12dB 101=+18dB 110=+24dB 111=+30dB	Input Limiter/ Automatic Level Control (ALC)		
33 (21h)	7:4	ALCHLD	0000	ALC hold time before gain is increased. 0000 = 0ms 0001 = 2.67ms 0010 = 5.33ms ... (time doubles with every step) 1111 = 43.691s	Input Limiter/ Automatic Level Control (ALC)		
	3:0	ALCLVL	1011	ALC target – sets signal level at ADC input 1111 : -1.5dBFS 1110 : -1.5dBFS 1101 : -3dBFS 1100 : -4.5dBFS ..... (-1.5dB steps) 0001 : -21dBFS 0000 : -22.5dBFS	Input Limiter/ Automatic Level Control (ALC)		
34 (22h)	8	ALCMODE	0	Determines the ALC mode of operation: 0=ALC mode 1=Limiter mode	Input Limiter/ Automatic Level Control (ALC)		
	7:4	ALCDCY [3:0]	0011	Decay (gain ramp-up) time (ALCMODE ==0)	Input Limiter/ Automatic Level Control (ALC)		
						Per step	Per 6dB
0000				410us		3.3ms	24ms
0001				820us		6.6ms	48ms
0010				1.64ms		13.1ms	192ms
... (time doubles with every step)							
1010 or higher	420ms	3.36s	24.576s				
0011			Decay (gain ramp-up) time (ALCMODE ==1)				
					Per step	Per 6dB	90% of range
			0000		90.8us	726.4us	5.26ms
			0001		181.6us	1.453ms	10.53ms
			0010		363.2us	2.905ms	21.06ms
			... (time doubles with every step)				
1010	93ms	744ms	5.39s				
3:0	ALCATK	0010	ALC attack (gain ramp-down) time (ALCMODE == 0)	Input Limiter/ Automatic Level Control (ALC)			
					Per step	Per 6dB	90% of range
			0000		104us	832us	6ms
			0001		208us	1.664ms	12ms
			0010		416us	3.328ms	24.1ms
			... (time doubles with every step)				
1010 or higher	106ms	852ms	6.18s				

REGISTER ADDRESS	BIT	LABEL	DEFAULT	DESCRIPTION	REFER TO																								
			0010	ALC attack (gain ramp-down) time (ALCMODE == 1)																									
				<table border="1"> <thead> <tr> <th></th> <th>Per step</th> <th>Per 6dB</th> <th>90% of range</th> </tr> </thead> <tbody> <tr> <td>0000</td> <td>22.7us</td> <td>182.4us</td> <td>1.31ms</td> </tr> <tr> <td>0001</td> <td>45.4us</td> <td>363.2us</td> <td>2.62ms</td> </tr> <tr> <td>0010</td> <td>90.8us</td> <td>726.4us</td> <td>5.26ms</td> </tr> <tr> <td colspan="4">... (time doubles with every step)</td> </tr> <tr> <td>1010</td> <td>23.2ms</td> <td>186ms</td> <td>1.348s</td> </tr> </tbody> </table>		Per step	Per 6dB	90% of range	0000	22.7us	182.4us	1.31ms	0001	45.4us	363.2us	2.62ms	0010	90.8us	726.4us	5.26ms	... (time doubles with every step)				1010	23.2ms	186ms	1.348s	
	Per step	Per 6dB	90% of range																										
0000	22.7us	182.4us	1.31ms																										
0001	45.4us	363.2us	2.62ms																										
0010	90.8us	726.4us	5.26ms																										
... (time doubles with every step)																													
1010	23.2ms	186ms	1.348s																										
35 (23h)	8:4		00000	Reserved																									
	3	NGEN	0	ALC Noise gate function enable 1 = enable 0 = disable	Input Limiter/ Automatic Level Control (ALC)																								
	2:0	NGTH	000	ALC Noise gate threshold: 000=-39dB 001=-45dB 010=-51db ... (6dB steps) 111=-81dB	Input Limiter/ Automatic Level Control (ALC)																								
36 (24h)	8:5		0000	Reserved																									
	4	PLL PRESCALE	0	0 = MCLK input not divided (default) 1 = Divide MCLK by 2 before input to PLL	Master Clock and Phase Locked Loop (PLL)																								
	3:0	PLLN[3:0]	1000	Integer (N) part of PLL input/output frequency ratio. Use values greater than 5 and less than 13.	Master Clock and Phase Locked Loop (PLL)																								
37 (25h)	8:6		000	Reserved																									
	5:0	PLLK[23:18]	01100	Fractional (K) part of PLL1 input/output frequency ratio (treat as one 24-digit binary number).	Master Clock and Phase Locked Loop (PLL)																								
38 (26h)	8:0	PLLK[17:9]	010010011	Fractional (K) part of PLL1 input/output frequency ratio (treat as one 24-digit binary number).	Master Clock and Phase Locked Loop (PLL)																								
39 (27h)	8:0	PLLK[8:0]	011101001	Fractional (K) part of PLL1 input/output frequency ratio (treat as one 24-digit binary number).	Master Clock and Phase Locked Loop (PLL)																								
40 (28h)	8:0		00000000	Reserved																									
41 (29h)	8:4		00000	Reserved																									
	3:0	DEPTH3D	0000	Stereo depth 0000: 0% (minimum 3D effect) 0001: 6.67% .... 1110: 93.3% 1111: 100% (maximum 3D effect)	3D Stereo Enhancement																								
43 (2Bh)	8:6		000	Reserved																									
	5	MUTERPGA2INV	0	Mute input to INVROUT2 mixer	Analogue Outputs																								
	4	INVROUT2	0	Mute input to INVROUT2 mixer	Analogue Outputs																								

REGISTER ADDRESS	BIT	LABEL	DEFAULT	DESCRIPTION	REFER TO
	3:1	BEEPVOL	000	AUXR input to ROUT2 inverter gain 000 = -15dB ... 111 = +6dB	Analogue Outputs
	0	BEEPEN	0	0 = mute AUXR beep input 1 = enable AUXR beep input	Analogue Outputs
44 (2Ch)	8	MBVSEL	0	Microphone Bias Voltage Control 0 = 0.9 * AVDD 1 = 0.65 * AVDD	Input Signal Path
	7		0	Reserved	
	6	R2_2INPPGA	0	Connect R2 pin to right channel input PGA positive terminal. 0=R2 not connected to input PGA 1=R2 connected to input PGA amplifier positive terminal (constant input impedance).	Input Signal Path
	5	RIN2INPPGA	1	Connect RIN pin to right channel input PGA negative terminal. 0=RIN not connected to input PGA 1=RIN connected to right channel input PGA amplifier negative terminal.	Input Signal Path
	4	RIP2INPPGA	1	Connect RIP pin to right channel input PGA amplifier positive terminal. 0 = RIP not connected to input PGA 1 = right channel input PGA amplifier positive terminal connected to RIP (constant input impedance)	Input Signal Path
	3		0	Reserved	
	2	L2_2INPPGA	0	Connect L2 pin to left channel input PGA positive terminal. 0=L2 not connected to input PGA 1=L2 connected to input PGA amplifier positive terminal (constant input impedance).	Input Signal Path
	1	LIN2INPPGA	1	Connect LIN pin to left channel input PGA negative terminal. 0=LIN not connected to input PGA 1=LIN connected to input PGA amplifier negative terminal.	Input Signal Path
	0	LIP2INPPGA	1	Connect LIP pin to left channel input PGA amplifier positive terminal. 0 = LIP not connected to input PGA 1 = input PGA amplifier positive terminal connected to LIP (constant input impedance)	Input Signal Path
45 (2Dh)	8	INPPGAUPDATE	N/A	INPPGAVOLL and INPPGAVOLR volume do not update until a 1 is written to INPPGAUPDATE (in reg 45 or 46)	Input Signal Path
	7	INPPGAZCL	0	Left channel input PGA zero cross enable: 0=Update gain when gain register changes 1=Update gain on 1 <sup>st</sup> zero cross after gain register write.	Input Signal Path
	6	INPPGAMUTEL	0	Mute control for left channel input PGA: 0=Input PGA not muted, normal operation 1=Input PGA muted (and disconnected from the following input BOOST stage).	Input Signal Path



REGISTER ADDRESS	BIT	LABEL	DEFAULT	DESCRIPTION	REFER TO
	5:0	INPPGAVOLL	010000	Left channel input PGA volume 000000 = -12dB 000001 = -11.25db . 010000 = 0dB . 111111 = 35.25dB	Input Signal Path
46 (2Eh)	8	INPPGAUPDATE	N/A	INPPGAVOLL and INPPGAVOLR volume do not update until a 1 is written to INPPGAUPDATE (in reg 45 or 46)	Input Signal Path
	7	INPPGAZCR	0	Right channel input PGA zero cross enable: 0=Update gain when gain register changes 1=Update gain on 1 <sup>st</sup> zero cross after gain register write.	Input Signal Path
	6	INPPGAMUTER	0	Mute control for right channel input PGA: 0=Input PGA not muted, normal operation 1=Input PGA muted (and disconnected from the following input BOOST stage).	Input Signal Path
	5:0	INPPGAVOLR	010000	Right channel input PGA volume 000000 = -12dB 000001 = -11.25db . 010000 = 0dB . 111111 = +35.25dB	Input Signal Path
47 (2Fh)	8	PGABOOSTL	1	Boost enable for left channel input PGA: 0 = PGA output has +0dB gain through input BOOST stage. 1 = PGA output has +20dB gain through input BOOST stage.	Input Signal Path
	7		0	Reserved	
	6:4	L2_2BOOSTVOL	000	Controls the L2 pin to the left channel input boost stage: 000=Path disabled (disconnected) 001=-12dB gain through boost stage 010=-9dB gain through boost stage ... 111=+6dB gain through boost stage	Input Signal Path
	3		0	Reserved	
	2:0	AUXL2BOOSTVOL	000	Controls the auxilliary amplifier to the left channel input boost stage: 000=Path disabled (disconnected) 001=-12dB gain through boost stage 010=-9dB gain through boost stage ... 111=+6dB gain through boost stage	Input Signal Path
48 (30h)	8	PGABOOSTR	1	Boost enable for right channel input PGA: 0 = PGA output has +0dB gain through input BOOST stage. 1 = PGA output has +20dB gain through input BOOST stage.	Input Signal Path
	7		0	Reserved	

REGISTER ADDRESS	BIT	LABEL	DEFAULT	DESCRIPTION	REFER TO
	6:4	R2_2BOOSTVOL	000	Controls the R2 pin to the right channel input boost stage: 000=Path disabled (disconnected) 001=-12dB gain through boost stage 010=-9dB gain through boost stage ... 111=+6dB gain through boost stage	Input Signal Path
	3		0	Reserved	
	2:0	AUXR2BOOSTVOL	000	Controls the auxilliary amplifier to the right channel input boost stage: 000=Path disabled (disconnected) 001=-12dB gain through boost stage 010=-9dB gain through boost stage ... 111=+6dB gain through boost stage	Input Signal Path
49 (31h)	8:7		00	Reserved	
	6	DACL2RMIX	0	Left DAC output to right output mixer 0 = not selected 1 = selected	Analogue Outputs
	5	DACR2LMIX	0	Right DAC output to left output mixer 0 = not selected 1 = selected	Analogue Outputs
	4	OUT4BOOST	0	0 = OUT4 output gain = -1; DC = AVDD / 2 1 = OUT4 output gain = +1.5 DC = 1.5 x AVDD / 2	Analogue Outputs
	3	OUT3BOOST	0	0 = OUT3 output gain = -1; DC = AVDD / 2 1 = OUT3 output gain = +1.5 DC = 1.5 x AVDD / 2	Analogue Outputs
	2	SPKBOOST	0	0 = speaker gain = -1; DC = AVDD / 2 1 = speaker gain = +1.5; DC = 1.5 x AVDD / 2	Analogue Outputs
	1	TSDEN	1	Thermal Shutdown Enable 0 : thermal shutdown disabled 1 : thermal shutdown enabled	Analogue Outputs
	0	VROI	0	VREF (AVDD/2 or 1.5xAVDD/2) to analogue output resistance 0: approx 1kΩ 1: approx 30 kΩ	Analogue Outputs
50 (32h)	8:6	AUXLMIXVOL	000	Aux left channel input to left mixer volume control: 000 = -15dB 001 = -12dB ... 101 = 0dB 110 = +3dB 111 = +6dB	Analogue Outputs
	5	AUXL2LMIX	0	Left Auxilliary input to left channel output mixer: 0 = not selected 1 = selected	Analogue Outputs

REGISTER ADDRESS	BIT	LABEL	DEFAULT	DESCRIPTION	REFER TO
	4:2	BYPLMIXVOL	000	Left bypass volume control to output channel mixer: 000 = -15dB 001 = -12dB ... 101 = 0dB 110 = +3dB 111 = +6dB	Analogue Outputs
	1	BYPL2L MIX	0	Left bypass path (from the left channel input boost output) to left output mixer 0 = not selected 1 = selected	Analogue Outputs
	0	DACL2L MIX	1	Left DAC output to left output mixer 0 = not selected 1 = selected	Analogue Outputs
51 (33h)	8:6	AUXRMIXVOL	000	Aux right channel input to right mixer volume control: 000 = -15dB 001 = -12dB ... 101 = 0dB 110 = +3dB 111 = +6dB	Analogue Outputs
	5	AUXR2RMIX	0	Right Auxilliary input to right channel output mixer: 0 = not selected 1 = selected	Analogue Outputs
	4:2	BYPRMIXVOL	000	Right bypass volume control to output channel mixer: 000 = -15dB 001 = -12dB ... 101 = 0dB 110 = +3dB 111 = +6dB	Analogue Outputs
	1	BYPR2RMIX	0	Right bypass path (from the right channel input boost output) to right output mixer 0 = not selected 1 = selected	Analogue Outputs
	0	DACR2RMIX	1	Right DAC output to right output mixer 0 = not selected 1 = selected	Analogue Outputs
52 (34h)	8	HPVU	N/A	LOUT1 and ROUT1 volumes do not update until a 1 is written to HPVU (in reg 52 or 53)	Analogue Outputs
	7	LOUT1ZC	0	Headphone volume zero cross enable: 1 = Change gain on zero cross only 0 = Change gain immediately	Analogue Outputs
	6	LOUT1MUTE	0	Left headphone output mute: 0 = Normal operation 1 = Mute	Analogue Outputs

REGISTER ADDRESS	BIT	LABEL	DEFAULT	DESCRIPTION	REFER TO
	5:0	LOUT1VOL	111001	Left headphone output volume: 000000 = -57dB ... 111001 = 0dB ... 111111 = +6dB	Analogue Outputs
53 (35h)	8	HPVU	N/A	LOUT1 and ROUT1 volumes do not update until a 1 is written to HPVU (in reg 52 or 53)	Analogue Outputs
	7	ROUT1ZC	0	Headphone volume zero cross enable: 1 = Change gain on zero cross only 0 = Change gain immediately	Analogue Outputs
	6	ROUT1MUTE	0	Right headphone output mute: 0 = Normal operation 1 = Mute	Analogue Outputs
	5:0	ROUT1VOL	111001	Right headphone output volume: 000000 = -57dB ... 111001 = 0dB ... 111111 = +6dB	Analogue Outputs
54 (36h)	8	SPKVU	N/A	LOUT2 and ROUT2 volumes do not update until a 1 is written to SPKVU (in reg 54 or 55)	Analogue Outputs
	7	LOUT2ZC	0	Speaker volume zero cross enable: 1 = Change gain on zero cross only 0 = Change gain immediately	Analogue Outputs
	6	LOUT2MUTE	0	Left speaker output mute: 0 = Normal operation 1 = Mute	Analogue Outputs
	5:0	LOUT2VOL	111001	Left speaker output volume: 000000 = -57dB ... 111001 = 0dB ... 111111 = +6dB	Analogue Outputs
55 (37h)	8	SPKVU	N/A	LOUT2 and ROUT2 volumes do not update until a 1 is written to SPKVU (in reg 54 or 55)	Analogue Outputs
	7	ROUT2ZC	0	Speaker volume zero cross enable: 1 = Change gain on zero cross only 0 = Change gain immediately	Analogue Outputs
	6	ROUT2MUTE	0	Right speaker output mute: 0 = Normal operation 1 = Mute	Analogue Outputs
	5:0	ROUT2VOL	111001	Right speaker output volume: 000000 = -57dB ... 111001 = 0dB ... 111111 = +6dB	Analogue Outputs
56 (38h)	8:7		00	Reserved	
	6	OUT3MUTE	0	0 = Output stage outputs OUT3 mixer 1 = Output stage muted – drives out VMID. Can be used as VMID buffer in this mode.	Analogue Outputs
	5:4		00	Reserved	

REGISTER ADDRESS	BIT	LABEL	DEFAULT	DESCRIPTION	REFER TO
	3	OUT4_2OUT3	0	OUT4 mixer output to OUT3 0 = disabled 1 = enabled	Analogue Outputs
	2	BYPL2OUT3	0	Left ADC input to OUT3 0 = disabled 1 = enabled	Analogue Outputs
	1	LMIX2OUT3	0	Left DAC mixer to OUT3 0 = disabled 1 = enabled	Analogue Outputs
	0	LDAC2OUT3	1	Left DAC output to OUT3 0 = disabled 1 = enabled	Analogue Outputs
57 (39h)	8:7		00	Reserved	
	6	OUT4MUTE	0	0 = Output stage outputs OUT4 mixer 1 = Output stage muted – drives out VMID. Can be used as VMID buffer in this mode.	Analogue Outputs
	5	HALFSIG	0	0=OUT4 normal output 1=OUT4 attenuated by 6dB	Analogue Outputs
	4	LMIX2OUT4	0	Left DAC mixer to OUT4 0 = disabled 1 = enabled	Analogue Outputs
	3	LDAC2OUT4	0	Left DAC to OUT4 0 = disabled 1 = enabled	Analogue Outputs
	2	BYPR2OUT4	0	Right ADC input to OUT4 0 = disabled 1 = enabled	Analogue Outputs
	1	RMIX2OUT4	0	Right DAC mixer to OUT4 0 = disabled 1 = enabled	Analogue Outputs
	0	RDAC2OUT4	1	Right DAC output to OUT4 0 = disabled 1 = enabled	Analogue Outputs

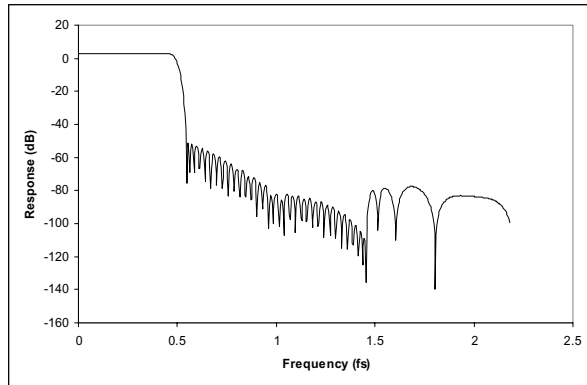
**DIGITAL FILTER CHARACTERISTICS**

PARAMETER	TEST CONDITIONS	MIN	TYP	MAX	UNIT
<b>ADC Filter</b>					
Passband	+/- 0.025dB	0		0.454fs	
	-6dB		0.5fs		
Passband Ripple				+/- 0.025	dB
Stopband		0.546fs			
Stopband Attenuation	f > 0.546fs	-60			dB
Group Delay			21/fs		
<b>ADC High Pass Filter</b>					
High Pass Filter Corner Frequency	-3dB		3.7		Hz
	-0.5dB		10.4		
	-0.1dB		21.6		
<b>DAC Filter</b>					
Passband	+/- 0.035dB	0		0.454fs	
	-6dB		0.5fs		
Passband Ripple				+/-0.035	dB
Stopband		0.546fs			
Stopband Attenuation	f > 0.546fs	-55			dB
Group Delay			29/fs		

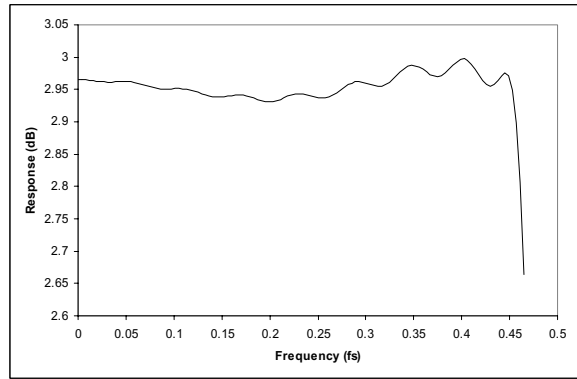
**Table 71 Digital Filter Characteristics****TERMINOLOGY**

1. Stop Band Attenuation (dB) – the degree to which the frequency spectrum is attenuated (outside audio band)
2. Pass-band Ripple – any variation of the frequency response in the pass-band region

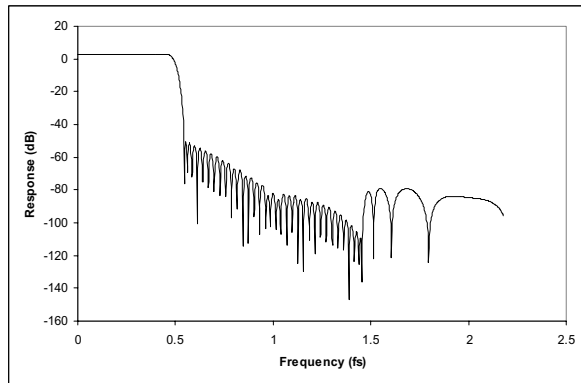
**DAC FILTER RESPONSES**



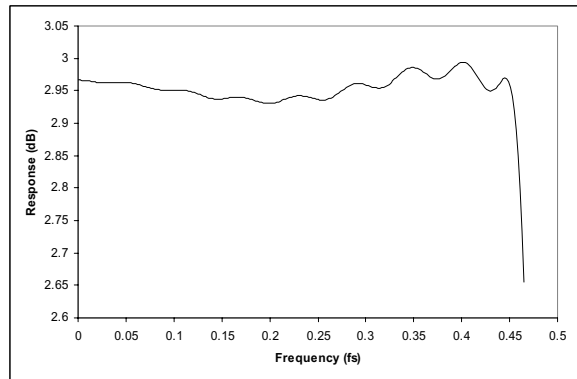
**Figure 48 DAC Digital Filter Frequency Response (128xOSR)**



**Figure 49 DAC Digital Filter Ripple (128xOSR)**

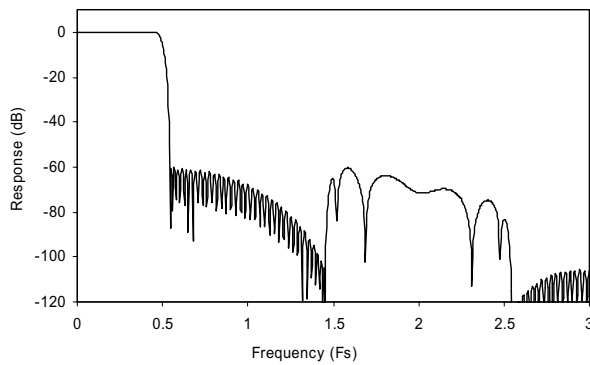


**Figure 50 DAC Digital Filter Frequency Response (64xOSR)**

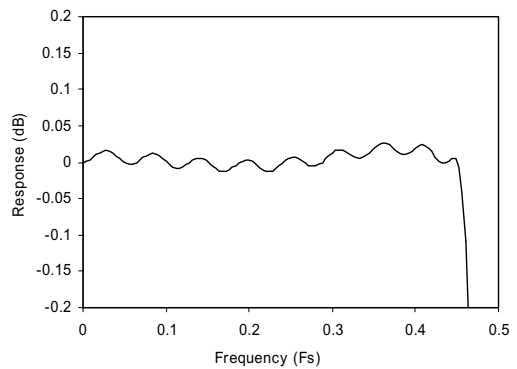


**Figure 51 DAC Digital Filter Ripple (64xOSR)**

**ADC FILTER RESPONSES**



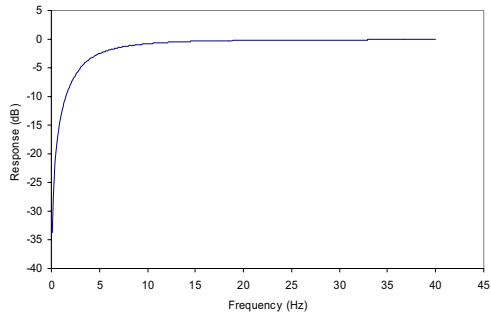
**Figure 52 ADC Digital Filter Frequency Response**



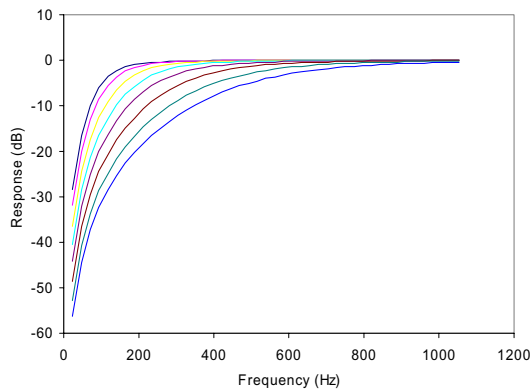
**Figure 53 ADC Digital Filter Ripple**

**HIGHPASS FILTER**

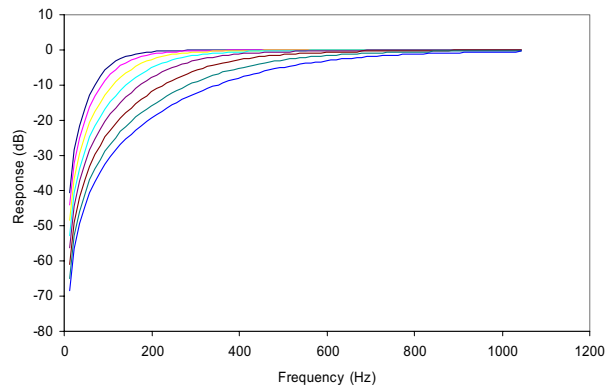
The WM8978 has a selectable digital highpass filter in the ADC filter path. This filter has two modes, audio and applications. In audio mode the filter is a 1<sup>st</sup> order IIR with a cut-off of around 3.7Hz. In applications mode the filter is a 2<sup>nd</sup> order high pass filter with a selectable cut-off frequency.



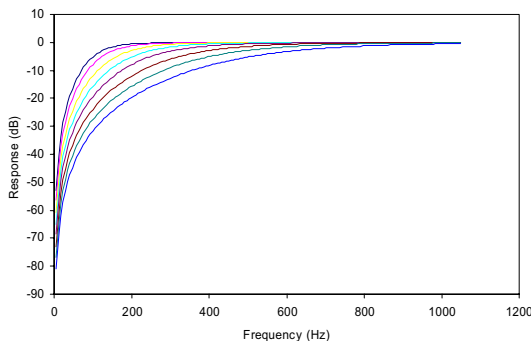
**Figure 54 ADC Highpass Filter Response, HPFAPP=0**



**Figure 55 ADC Highpass Filter Responses (48kHz), HPFAPP=1, all cut-off settings shown.**



**Figure 56 ADC Highpass Filter Responses (24kHz), HPFAPP=1, all cut-off settings shown.**



**Figure 57 ADC Highpass Filter Responses (12kHz), HPFAPP=1, all cut-off settings shown.**



### 5-BAND EQUALISER

The WM8978 has a 5-band equaliser which can be applied to either the ADC path or the DAC path. The plots from Figure 58 to Figure 71 show the frequency responses of each filter with a sampling frequency of 48kHz, firstly showing the different cut-off/centre frequencies with a gain of  $\pm 12\text{dB}$ , and secondly a sweep of the gain from  $-12\text{dB}$  to  $+12\text{dB}$  for the lowest cut-off/centre frequency of each filter.

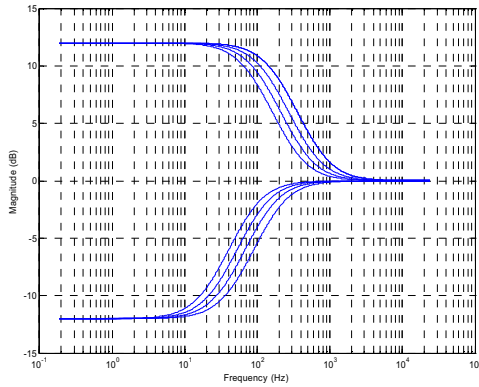


Figure 58 EQ Band 1 Low Frequency Shelf Filter Cut-offs

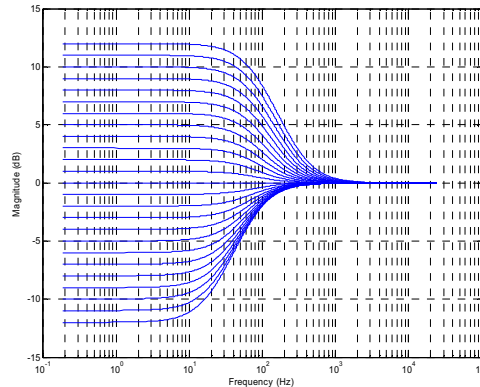


Figure 59 EQ Band 1 Gains for Lowest Cut-off Frequency

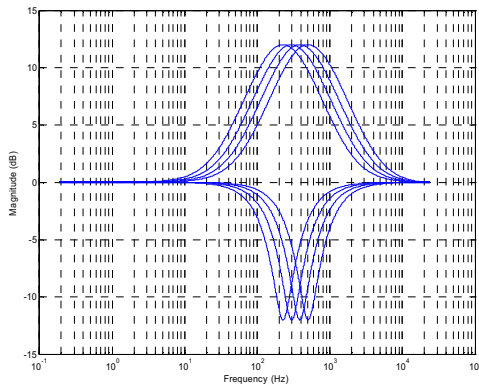


Figure 60 EQ Band 2 – Peak Filter Centre Frequencies, EQ2BW=0

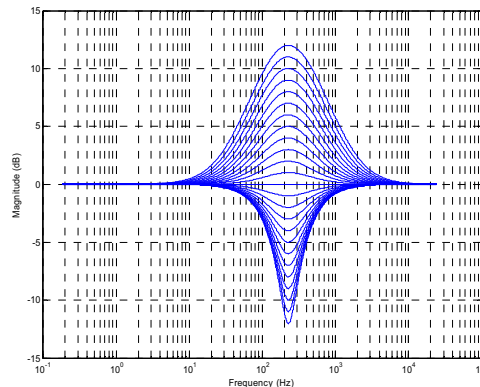


Figure 61 EQ Band 2 – Peak Filter Gains for Lowest Cut-off Frequency, EQ2BW=0

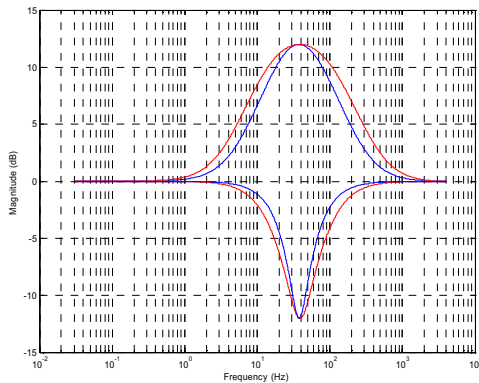


Figure 62 EQ Band 2 – EQ2BW=0, EQ2BW=1

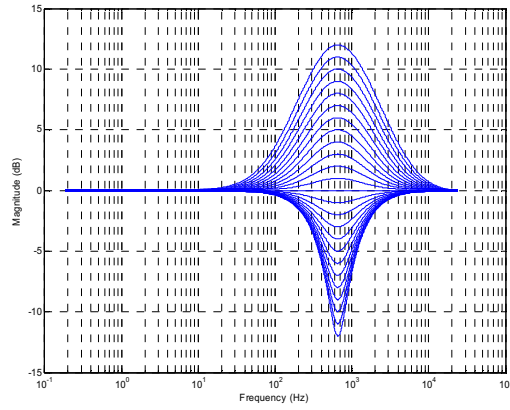
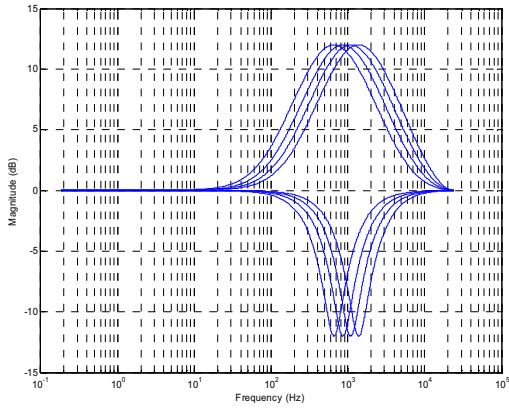


Figure 63 EQ Band 3 – Peak Filter Centre Frequencies, EQ3| Figure 64 EQ Band 3 – Peak Filter Gains for Lowest Cut-off Frequency, EQ3BW=0

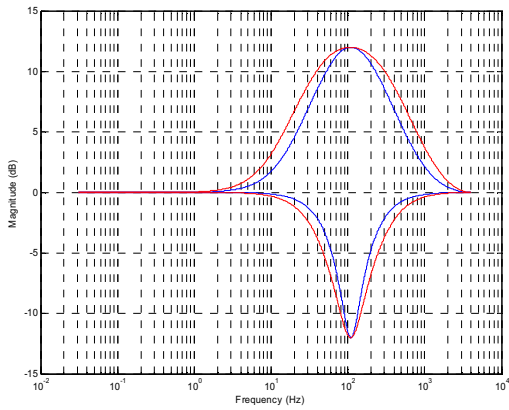
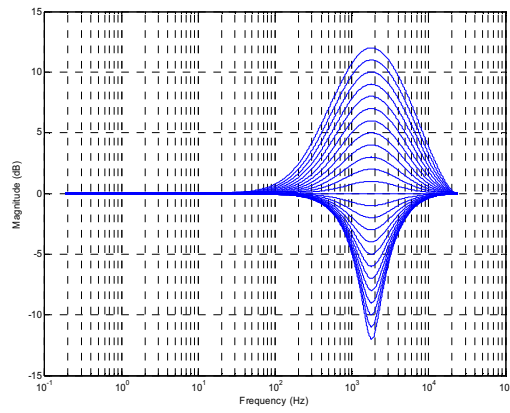
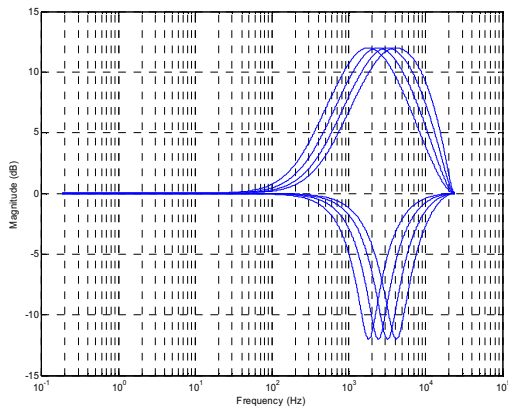
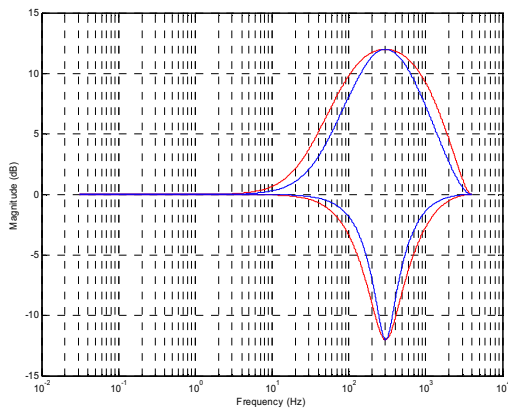


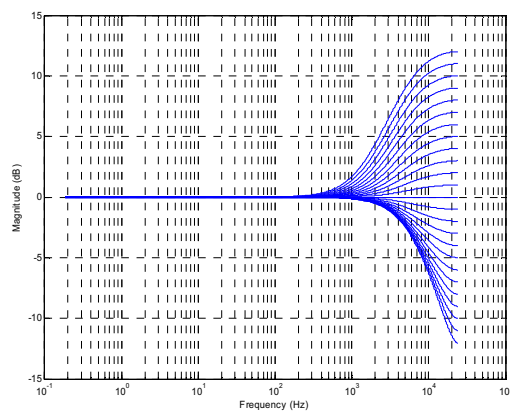
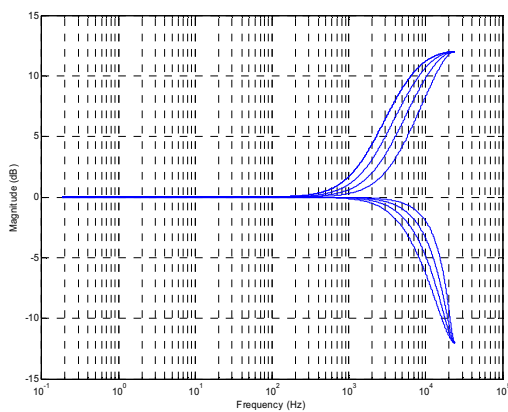
Figure 65 EQ Band 3 – EQ3BW=0, EQ3BW=1



**Figure 66 EQ Band 4 – Peak Filter Centre Frequencies, EQ3** **Figure 67 EQ Band 4 – Peak Filter Gains for Lowest Cut-off Frequency, EQ4BW=0**



**Figure 68 EQ Band 4 – EQ3BW=0, EQ3BW=1**



**Figure 69 EQ Band 5 High Frequency Shelf Filter Cut-offs** **Figure 70 EQ Band 5 Gains for Lowest Cut-off Frequency**

Figure 71 shows the result of having the gain set on more than one channel simultaneously. The blue traces show each band (lowest cut-off/centre frequency) with  $\pm 12\text{dB}$  gain. The red traces show the cumulative effect of all bands with  $+12\text{dB}$  gain and all bands  $-12\text{dB}$  gain, with EqxBW=0 for the peak filters.

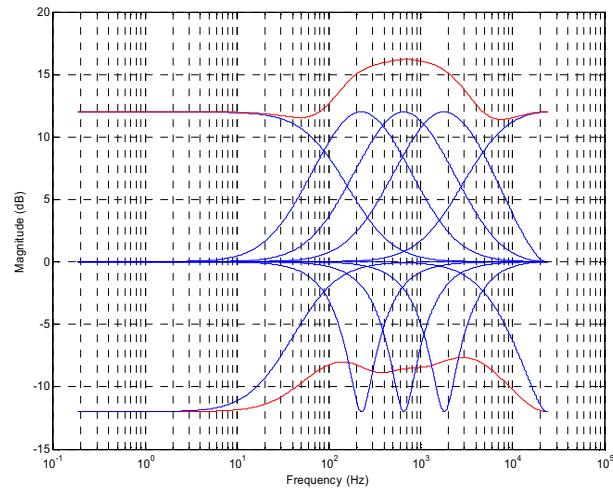


Figure 71 Cumulative Frequency Boost/Cut

## APPLICATION INFORMATION

### RECOMMENDED EXTERNAL COMPONENTS

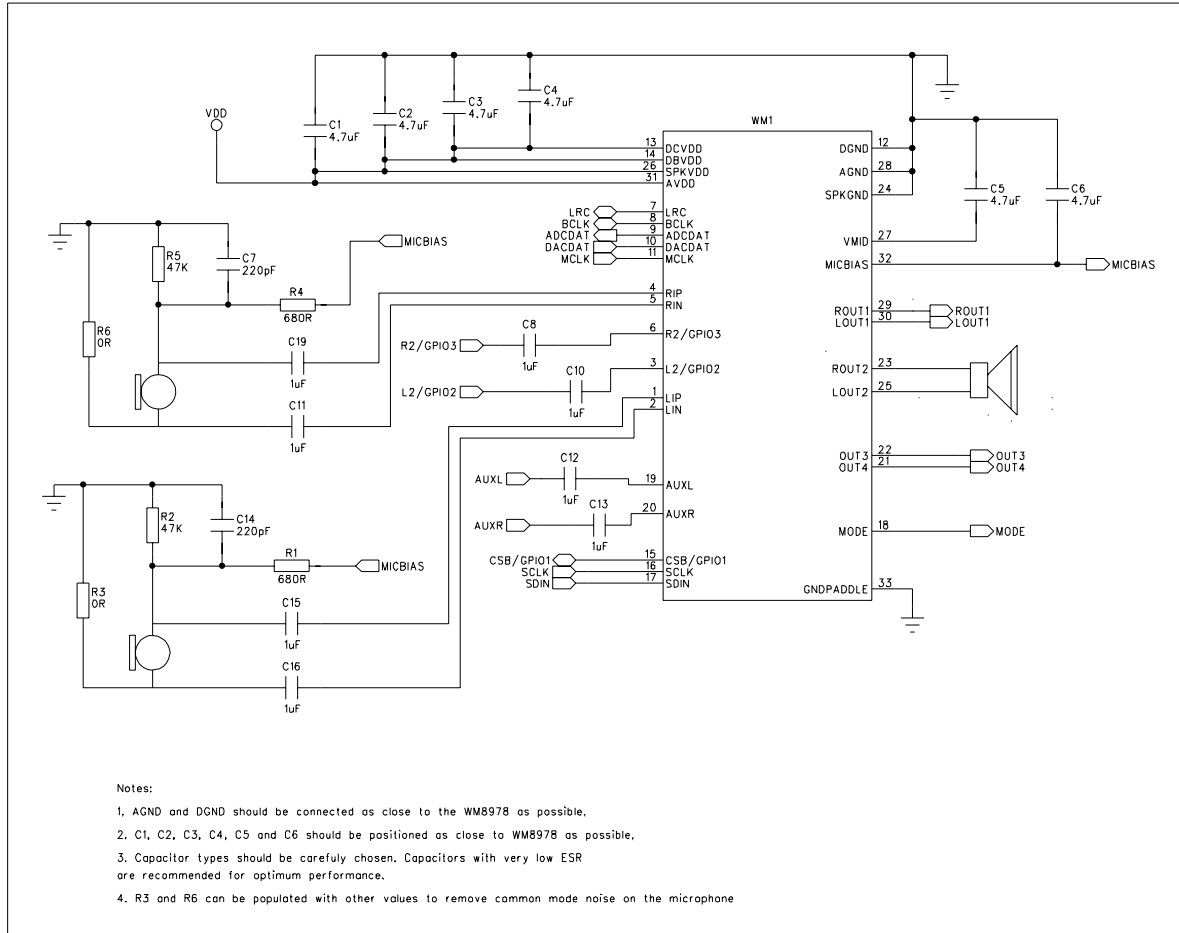
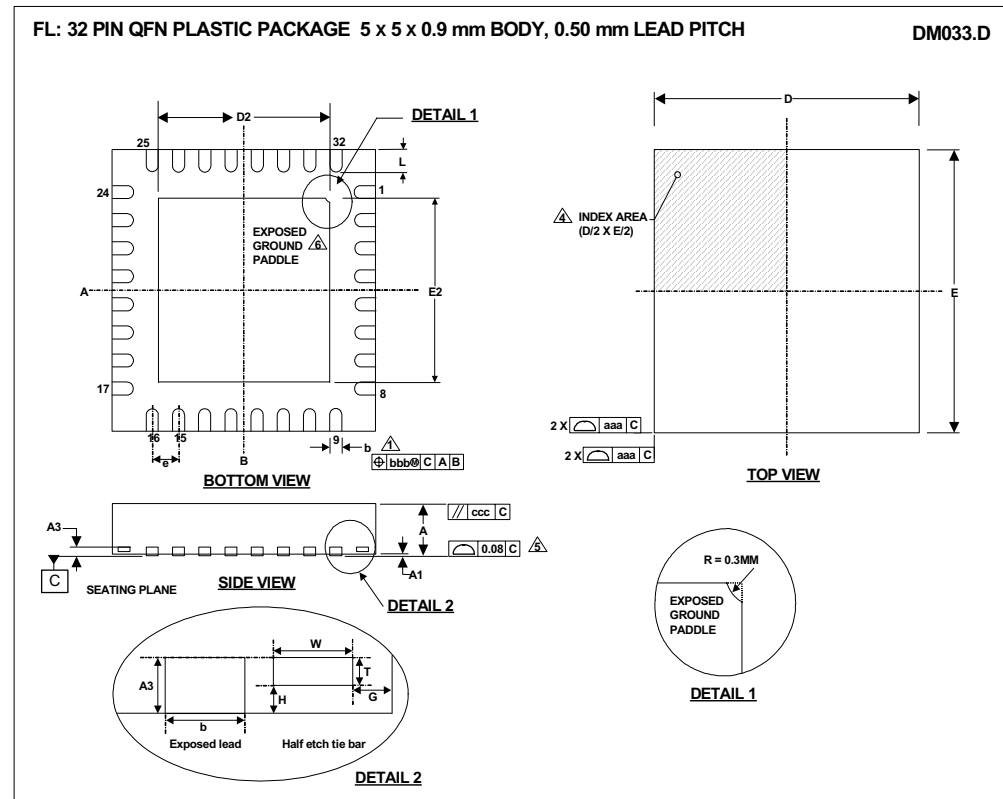


Figure 72 Recommended External Component Diagram

PACKAGE DIAGRAM



Symbols	Dimensions (mm)			
	MIN	NOM	MAX	NOTE
A	0.80	0.90	1.00	
A1	0	0.02	0.05	
A3		0.20 REF		
b	0.18	0.25	0.30	1
D		5.00		
D2	3.30	3.45	3.55	2
E		5.00		
E2	3.30	3.45	3.55	2
e		0.50 BSC		
G		0.213		
H		0.1		
L	0.30	0.40	0.50	
T		0.1		
W		0.2		
<b>Tolerances of Form and Position</b>				
aaa		0.15		
bbb		0.10		
ccc		0.10		
REF:	JEDEC, MO-220, VARIATION VHHD-5.			

- NOTES:
- DIMENSION  $b$  APPLIES TO METALLIZED TERMINAL AND IS MEASURED BETWEEN 0.15 mm AND 0.30 mm FROM TERMINAL TIP.
  - FALLS WITHIN JEDEC, MO-220, VARIATION VHHD-5.
  - ALL DIMENSIONS ARE IN MILLIMETRES.
  - THE TERMINAL #1 IDENTIFIER AND TERMINAL NUMBERING CONVENTION SHALL CONFORM TO JEDEC 95-1 SPP-002.
  - COPLANARITY APPLIES TO THE EXPOSED HEAT SINK SLUG AS WELL AS THE TERMINALS.
  - REFER TO APPLICATION NOTE WAN\_0118 FOR FURTHER INFORMATION REGARDING PCB FOOTPRINTS AND QFN PACKAGE SOLDERING.
  - THIS DRAWING IS SUBJECT TO CHANGE WITHOUT NOTICE.

## IMPORTANT NOTICE

Wolfson Microelectronics plc (WM) reserve the right to make changes to their products or to discontinue any product or service without notice, and advise customers to obtain the latest version of relevant information to verify, before placing orders, that information being relied on is current. All products are sold subject to the WM terms and conditions of sale supplied at the time of order acknowledgement, including those pertaining to warranty, patent infringement, and limitation of liability.

WM warrants performance of its products to the specifications applicable at the time of sale in accordance with WM's standard warranty. Testing and other quality control techniques are utilised to the extent WM deems necessary to support this warranty. Specific testing of all parameters of each device is not necessarily performed, except those mandated by government requirements.

In order to minimise risks associated with customer applications, adequate design and operating safeguards must be used by the customer to minimise inherent or procedural hazards. Wolfson products are not authorised for use as critical components in life support devices or systems without the express written approval of an officer of the company. Life support devices or systems are devices or systems that are intended for surgical implant into the body, or support or sustain life, and whose failure to perform when properly used in accordance with instructions for use provided, can be reasonably expected to result in a significant injury to the user. A critical component is any component of a life support device or system whose failure to perform can be reasonably expected to cause the failure of the life support device or system, or to affect its safety or effectiveness.

WM assumes no liability for applications assistance or customer product design. WM does not warrant or represent that any license, either express or implied, is granted under any patent right, copyright, mask work right, or other intellectual property right of WM covering or relating to any combination, machine, or process in which such products or services might be or are used. WM's publication of information regarding any third party's products or services does not constitute WM's approval, license, warranty or endorsement thereof.

Reproduction of information from the WM web site or datasheets is permissible only if reproduction is without alteration and is accompanied by all associated warranties, conditions, limitations and notices. Representation or reproduction of this information with alteration voids all warranties provided for an associated WM product or service, is an unfair and deceptive business practice, and WM is not responsible nor liable for any such use.

Resale of WM's products or services with statements different from or beyond the parameters stated by WM for that product or service voids all express and any implied warranties for the associated WM product or service, is an unfair and deceptive business practice, and WM is not responsible nor liable for any such use.

### ADDRESS:

Wolfson Microelectronics plc  
Westfield House  
26 Westfield Road  
Edinburgh  
EH11 2QB  
United Kingdom

Tel :: +44 (0)131 272 7000  
Fax :: +44 (0)131 272 7001  
Email :: [sales@wolfsonmicro.com](mailto:sales@wolfsonmicro.com)