

Mono CODEC with Speaker Driver

DESCRIPTION

The WM8974 is a low power, high quality mono CODEC designed for portable applications such as Digital Still Camera or Digital Voice Recorder.

The device integrates support for a differential or single ended mic, and includes drivers for speakers or headphone, and mono line output. External component requirements are reduced as no separate microphone or headphone amplifiers are required.

Advanced Sigma Delta Converters are used along with digital decimation and interpolation filters to give high quality audio at sample rates from 8 to 48ks/s. Additional digital filtering options are available in the ADC path, to cater for application filtering such as 'wind noise reduction', plus an advanced mixed signal ALC function with noise gate is provided. The digital audio interface supports A-law and μ -law companding.

An on-chip PLL is provided to generate the required Master Clock from an external reference clock. The PLL clock can also be output if required elsewhere in the system.

The WM8974 operates at supply voltages from 2.5 to 3.6V, although the digital supplies can operate at voltages down to 1.71V to save power. The speaker and mono outputs use a separate supply of up to 5V which enables increased output power if required. Different sections of the chip can also be powered down under software control by way of the selectable two or three wire control interface.

WM8974 is supplied in a very small 4x4mm QFN package, offering high levels of functionality in minimum board area, with high thermal performance.

FEATURES

- **Mono CODEC:**
- Audio sample rates: 8, 11.025, 16, 22.05, 24, 32, 44.1, 48kHz
- DAC SNR 98dB, THD -84dB ('A'-weighted @ 8 – 48ks/s)
- ADC SNR 94dB, THD -83dB ('A'-weighted @ 8 – 48ks/s)
- On-chip Headphone/Speaker Driver with 'cap-less' connect
 - 40mW output power into 16 Ω / 3.3V SPKVDD
 - BTL speaker drive 0.9W into 8 Ω / 5V SPKVDD
- Additional MONO Line output
- Multiple analog or 'Aux' inputs, plus analog bypass path
- **Mic Preamps:**
- Differential or single end Microphone Interface
 - Programmable preamp gain
 - Pseudo differential inputs with common mode rejection
 - Programmable ALC / Noise Gate in ADC path
- Low-noise bias supplied for electret microphones

OTHER FEATURES

- 5 band EQ (record or playback path)
- Digital Playback Limiter
- Programmable ADC High Pass Filter (wind noise reduction)
- Programmable ADC Notch Filter
- On-chip PLL
- Low power, low voltage
 - 2.5V to 3.6V (digital: 1.71V to 3.6V)
 - power consumption <10mA all-on 48ks/s mode
- 4x4x0.9mm 24 lead QFN package

APPLICATIONS

- Digital Still Camera Audio Codec
- Wireless VoIP and other communication device handsets / headsets
- Portable audio recorder
- General Purpose low power audio CODEC

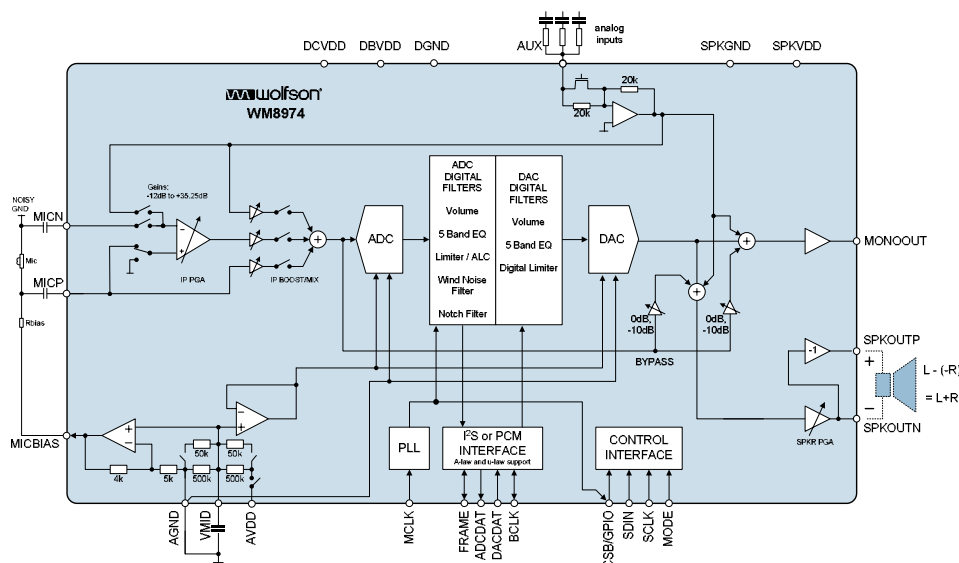
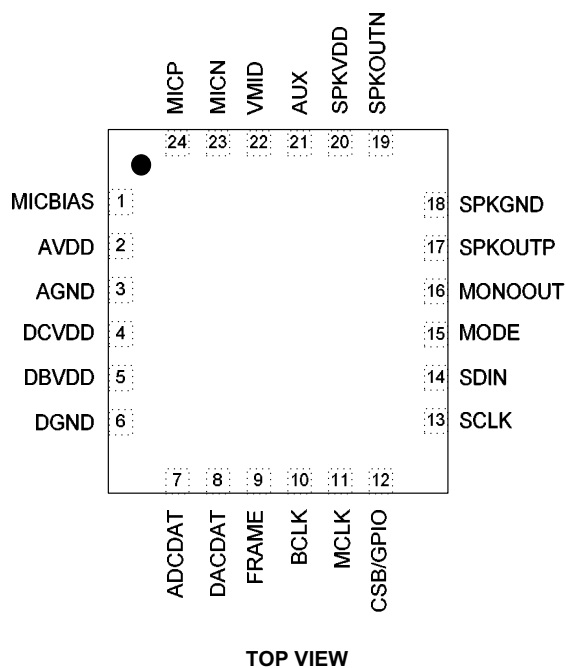

TABLE OF CONTENTS

DESCRIPTION	1
FEATURES.....	1
APPLICATIONS	1
TABLE OF CONTENTS	2
PIN CONFIGURATION.....	3
ORDERING INFORMATION	3
RECOMMENDED OPERATING CONDITIONS	5
ELECTRICAL CHARACTERISTICS	6
TERMINOLOGY	8
SIGNAL TIMING REQUIREMENTS	9
SYSTEM CLOCK TIMING	9
AUDIO INTERFACE TIMING – MASTER MODE	9
AUDIO INTERFACE TIMING – SLAVE MODE.....	10
CONTROL INTERFACE TIMING – 3-WIRE MODE	11
CONTROL INTERFACE TIMING – 2-WIRE MODE	12
DEVICE DESCRIPTION	13
INTRODUCTION.....	13
INPUT SIGNAL PATH.....	14
ANALOGUE TO DIGITAL CONVERTER (ADC).....	19
INPUT AUTOMATIC LEVEL CONTROL (ALC).....	22
OUTPUT SIGNAL PATH.....	33
ANALOGUE OUTPUTS.....	40
OUTPUT SWITCH	45
DIGITAL AUDIO INTERFACES.....	47
AUDIO SAMPLE RATES.....	52
MASTER CLOCK AND PHASE LOCKED LOOP (PLL).....	53
GENERAL PURPOSE INPUT/OUTPUT	55
CONTROL INTERFACE.....	55
RESETTING THE CHIP.....	56
POWER SUPPLIES	56
POWER MANAGEMENT	61
REGISTER MAP.....	63
REGISTER BITS BY ADDRESS	65
DIGITAL FILTER CHARACTERISTICS	76
TERMINOLOGY	76
DAC FILTER RESPONSES.....	77
ADC FILTER RESPONSES.....	77
DE-EMPHASIS FILTER RESPONSES.....	78
HIGHPASS FILTER.....	79
5-BAND EQUALISER.....	80
APPLICATIONS INFORMATION	84
RECOMMENDED EXTERNAL COMPONENTS	84
PACKAGE DIAGRAM	85
IMPORTANT NOTICE	86
ADDRESS	86

PIN CONFIGURATION



ORDERING INFORMATION

ORDER CODE	TEMPERATURE RANGE	PACKAGE	MOISTURE SENSITIVITY LEVEL	PACKAGE BODY TEMPERATURE
WM8974GEFL/V	-25°C to +85°C	24-lead QFN (4x4x0.9mm) (Pb-free)	MSL3	260°C
WM8974GEFL/RV	-25°C to +85°C	24-lead QFN (4x4x0.9mm) (Pb-free, tape and reel)	MSL3	260°C

Note:

Reel Quantity = 3,500

PIN DESCRIPTION

PIN NO	NAME	TYPE	DESCRIPTION
1	MICBIAS	Analogue Output	Microphone bias
2	AVDD	Supply	Analogue supply (feeds ADC and DAC)
3	AGND	Supply	Analogue ground (feeds ADC and DAC)
4	DCVDD	Supply	Digital core supply
5	DBVDD	Supply	Digital buffer (input/output) supply
6	DGND	Supply	Digital ground
7	ADCDAT	Digital Output	ADC digital audio data output
8	DACDAT	Digital Input	DAC digital audio data input
9	FRAME	Digital Input / Output	DAC and ADC sample rate clock or frame synch
10	BCLK	Digital Input / Output	Digital audio port clock
11	MCLK	Digital Input	Master clock input
12	CSB/GPIO	Digital Input / Output	3-Wire MPU chip select or general purpose input/output pin.
13	SCLK	Digital Input	3-Wire MPU clock Input / 2-Wire MPU Clock Input
14	SDIN	Digital Input / Output	3-Wire MPU data Input / 2-Wire MPU Data Input
15	MODE	Digital Input	Control interface mode selection pin.
16	MONOOUT	Analogue Output	Mono output
17	SPKOUTP	Analogue Output	Speaker output positive
18	SPKGND	Supply	Speaker ground (feeds speaker and mono output amps only)
19	SPKOUTN	Analogue Output	Speaker output Negative
20	SPKVDD	Supply	Speaker supply (feeds speaker and mono output amps only)
21	AUX	Analogue Input	Auxiliary analogue input
22	VMID	Reference	Decoupling for midrail reference voltage
23	MICN	Analogue Input	Microphone negative input
24	MICP	Analogue Input	Microphone positive input (common mode)

Note:

It is recommended that the QFN ground paddle should be connected to analogue ground on the application PCB.

ABSOLUTE MAXIMUM RATINGS

Absolute Maximum Ratings are stress ratings only. Permanent damage to the device may be caused by continuously operating at or beyond these limits. Device functional operating limits and guaranteed performance specifications are given under Electrical Characteristics at the test conditions specified.



ESD Sensitive Device. This device is manufactured on a CMOS process. It is therefore generically susceptible to damage from excessive static voltages. Proper ESD precautions must be taken during handling and storage of this device.

Wolfson tests its package types according to IPC/JEDEC J-STD-020B for Moisture Sensitivity to determine acceptable storage conditions prior to surface mount assembly. These levels are:

MSL1 = unlimited floor life at <30°C / 85% Relative Humidity. Not normally stored in moisture barrier bag.

MSL2 = out of bag storage for 1 year at <30°C / 60% Relative Humidity. Supplied in moisture barrier bag.

MSL3 = out of bag storage for 168 hours at <30°C / 60% Relative Humidity. Supplied in moisture barrier bag.

The Moisture Sensitivity Level for each package type is specified in Ordering Information.

CONDITION	MIN	MAX
DBVDD, DCVDD, AVDD supply voltages	-0.3V	+4.2
SPKVDD supply voltage	-0.3V	+7V
Voltage range digital inputs	DGND -0.3V	DVDD +0.3V
Voltage range analogue inputs	AGND -0.3V	AVDD +0.3V
Operating temperature range, T _A	-25°C	+85°C
Storage temperature prior to soldering	30°C max / 85% RH max	
Storage temperature after soldering	-65°C	+150°C

Notes

1. Analogue and digital grounds must always be within 0.3V of each other.
2. All digital and analogue supplies are completely independent from each other.

RECOMMENDED OPERATING CONDITIONS

PARAMETER	SYMBOL	TEST CONDITIONS	MIN	TYP	MAX	UNIT
Digital supply range (Core)	DCVDD		1.71		3.6	V
Digital supply range (Buffer)	DBVDD		1.71		3.6	V
Analogue supplies range	AVDD		2.5		3.6	V
Speaker supply	SPKVDD		2.5		5.5	V
Ground	DGND,AGND,SPKGND			0		V

Notes

1. When using PLL, DCVDD must be 1.9V or higher.
2. AVDD must be \geq DCVDD.
3. DBVDD must be \geq DCVDD.
4. In non-boosted mode, SPKVDD must be \geq AVDD, if boosted SPKVDD must be \geq 1.5x AVDD.
5. When using PLL, DCVDD must be \geq 1.9V.

ELECTRICAL CHARACTERISTICS

Test Conditions

DCVDD = 1.8V, AVDD = DBVDD = 3.3V, SPKVDD = 3.3V, T_A = +25°C, 1kHz signal, fs = 48kHz, 24-bit audio data unless otherwise stated.

PARAMETER	SYMBOL	TEST CONDITIONS	MIN	TYP	MAX	UNIT
Microphone Inputs (MICN, MICP)						
Full-scale Input Signal Level (Note 1) – note this changes with AVDD	V _{INFS}	PGABOOST = 0dB INPPGAVOL = 0dB		1.0 0		V _{rms} dBV
Mic PGA equivalent input noise	At 35.25dB gain			150		µV
Input resistance	R _{MICIN}	Gain set to 35.25dB		1.6		kΩ
Input resistance	R _{MICIN}	Gain set to 0dB		47		kΩ
Input resistance	R _{MICIN}	Gain set to -12dB		75		kΩ
Input resistance	R _{MICIP}	MICP2INPPGA = 1		94		kΩ
Input resistance	R _{MICIP}	MICP2INPPGA = 0		TBD		kΩ
Input Capacitance	C _{MICIN}			10		pF
MIC Input Programmable Gain Amplifier (PGA)						
Programmable Gain			-12		35.25	dB
Programmable Gain Step Size		Guaranteed monotonic		0.75		dB
Mute Attenuation				108		dB
Selectable Input Gain Boost (0/+20dB)						
Gain Boost			0		20	dB
Automatic Level Control (ALC)/Limiter – ADC only						
Target Record Level			-28.5		-6	dB
Programmable Gain			-12		35.25	dB
Programmable Gain Step Size		Guaranteed Monotonic		0.75		dB
Gain Hold Time (Note 2)	t _{HOLD}	MCLK=12.288MHz (Note 4)	0, 2.67, 5.33, 10.67, ... , 43691 (time doubles with each step)			ms
Gain Ramp-Up (Decay) Time (Note 3)	t _{DCY}	ALCMODE=0 (ALC), MCLK=12.288MHz (Note 4)	3.3, 6.6, 13.1, ... , 3360 (time doubles with each step)			ms
		ALCMODE=1 (limiter), MCLK=12.288MHz (Note 4)	0.73, 1.45, 2.91, ... , 744 (time doubles with each step)			
Gain Ramp-Down (Attack) Time (Note 3)	t _{ATK}	ALCMODE=0 (ALC), MCLK=12.288MHz (Note 4)	0.83, 1.66, 3.33, ... , 852 (time doubles with each step)			ms
		ALCMODE=1 (limiter), MCLK=12.288MHz (Note 4)	0.18, 0.36, 0.73, ... , 186 (time doubles with each step)			
Analogue to Digital Converter (ADC)						
Signal to Noise Ratio (Note 5)	SNR	A-weighted, 0dB PGA gain	85	94		dB
Total Harmonic Distortion (Note 6)	THD	-1dBFS input, 0dB PGA gain	-75	-83		dB
Auxiliary Analogue Input (AUX)						
Full-scale Input Signal Level (0dB) – note this changes with AVDD	V _{INFS}			1.0 0		V _{rms} dBV
Input Resistance	R _{AUXIN}	AUXMODE=0		20		kΩ
Input Capacitance	C _{AUXIN}			10		pF

Test Conditions

DCVDD = 1.8V, AVDD = DBVDD = 3.3V, SPKVDD = 3.3V, T_A = +25°C, 1kHz signal, f_s = 48kHz, 24-bit audio data unless otherwise stated.

PARAMETER	SYMBOL	TEST CONDITIONS	MIN	TYP	MAX	UNIT
Digital to Analogue Converter (DAC) to MONO output (all data measured with 10kΩ / 50pF load)						
Signal to Noise Ratio (Note 5)	SNR	A-weighted	90	98		dB
Total Harmonic Distortion + Noise (Note 6)	THD+N	R _L = 10 kΩ full-scale signal		-84		dB
0dB Full Scale output voltage (Note 9)		MONOBOOST=0		AVDD/3.3		V _{RMS}
		MONOBOOST=1		1.5x (AVDD/3.3)		
Speaker Output PGA						
Programmable Gain			-57		6	dB
Programmable Gain Step Size		Guaranteed monotonic		1		dB
BTL Speaker Output (SPKOUTP, SPKOUTN with 8Ω bridge tied load)						
Output Power	P _O	Output power is very closely correlated with THD; see below				
Total Harmonic Distortion + Noise (Note 6)	THD+N	P _O = 180mW, R _L = 8Ω, SPKVDD=3.3V		0.03 -70		% dB
		P _O = 400mW, R _L = 8Ω, SPKVDD=3.3V		5.0 -26		% dB
		P _O = 360mW, R _L = 8Ω, SPKVDD=5V		0.02 -75		% dB
		P _O = 800mW, R _L = 8Ω, SPKVDD=5V		0.06 -65		% dB
Signal to Noise Ratio	SNR	SPKVDD=3.3V, R _L = 8Ω	90	101		dB
		SPKVDD=5V, R _L = 8Ω		102		dB
Power Supply Rejection Ratio				50		dB
'Headphone' output (SPKOUTP, SPKOUTN with resistive load to ground)						
Signal to Noise Ratio	SNR			100		dB
Total Harmonic Distortion + Noise (Note 6)	THD+N	P _O =20mW, R _L = 16Ω, SPKVDD=3.3V		0.02 -74		% dB
		P _O =20mW, R _L = 32Ω, SPKVDD=3.3V		0.017 - 75		% dB
Microphone Bias						
Bias Voltage (MBVSEL=0)	V _{MICBIAS}			0.9*AVDD		V
Bias Voltage (MBVSEL=1)	V _{MICBIAS}			0.65*AVDD		V
Bias Current Source	I _{MICBIAS}				3	mA
Output Noise Voltage	V _n	1K to 20kHz		15		nV/√Hz
Digital Input / Output						
Input HIGH Level	V _{IH}		0.7×DVDD			V
Input LOW Level	V _{IL}				0.3×DVDD	V
Output HIGH Level	V _{OH}	I _{OL} =1mA	0.9×DVDD			V
Output LOW Level	V _{OL}	I _{OH} =1mA			0.1×DVDD	V

TERMINOLOGY

1. MICN input only in single ended microphone configuration. Maximum input signal to MICP without distortion is -3dBV.
2. Hold Time is the length of time between a signal detected being too quiet and beginning to ramp up the gain. It does not apply to ramping down the gain when the signal is too loud, which happens without a delay.
3. Ramp-up and Ramp-Down times are defined as the time it takes for the PGA to change it's gain by 6dB.
4. All hold, ramp-up and ramp-down times scale proportionally with MCLK
5. Signal-to-noise ratio (dB) – SNR is a measure of the difference in level between the full scale output and the output with no signal applied. (No Auto-zero or Automute function is employed in achieving these results).
6. THD+N (dB) – THD+N is a ratio, of the rms values, of (Noise + Distortion)/Signal.
7. The maximum output voltage can be limited by the speaker power supply. If MONOBOOST=1 then SPKVDD should be 1.5xAVDD or higher to prevent clipping taking place in the output stage.

SIGNAL TIMING REQUIREMENTS

SYSTEM CLOCK TIMING

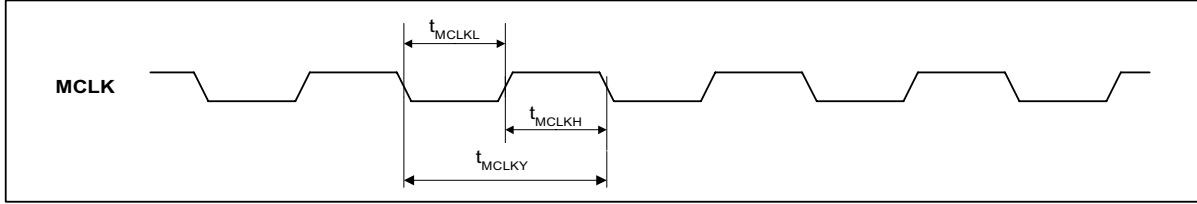

Figure 1 System Clock Timing Requirements

Test Conditions

DCVDD=1.8V, DBVDD=AVDD=SPKVDD=3.3V, DGND=AGND=SPKGND=0V, T_A = +25°C

PARAMETER	SYMBOL	CONDITIONS	MIN	TYP	MAX	UNIT
System Clock Timing Information						
MCLK cycle time	T _{MCLKY}	MCLK=SYSCLK (=256fs)	81.38			ns
		MCLK input to PLL ^{Note 1}	20			ns
MCLK duty cycle	T _{MCLKDS}		60:40		40:60	

Note 1:

PLL pre-scaling and PLL N and K values should be set appropriately so that SYSCLK is no greater than 12.288MHz.

AUDIO INTERFACE TIMING – MASTER MODE

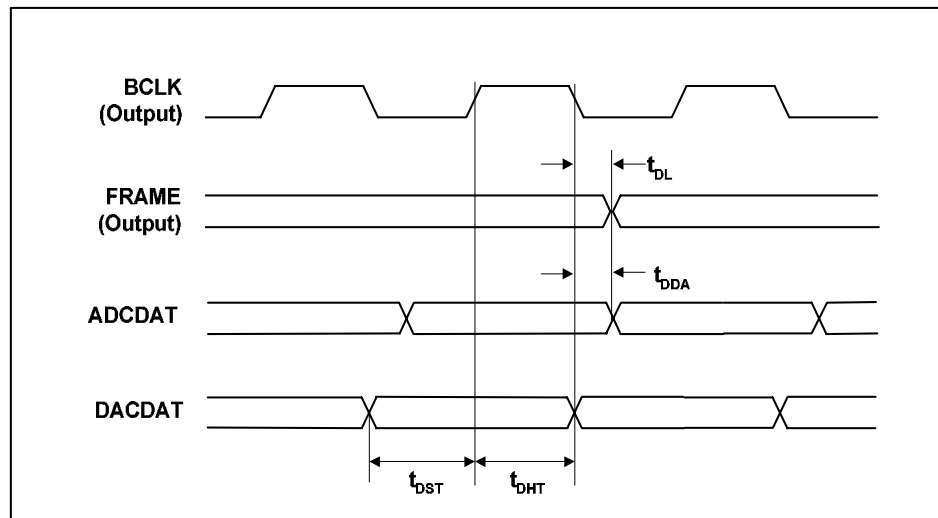

Figure 2 Digital Audio Data Timing – Master Mode (see Control Interface)

Test Conditions

DCVDD=1.8V, DBVDD=AVDD=SPKVDD=3.3V, DGND=AGND=SPKGND=0V, TA=+25°C, Master Mode, fs=48kHz, MCLK=256fs, 24-bit data, unless otherwise stated.

PARAMETER	SYMBOL	MIN	TYP	MAX	UNIT
Audio Data Input Timing Information					
FRAME propagation delay from BCLK falling edge	t _{DL}			10	ns
ADCDAT propagation delay from BCLK falling edge	t _{DDA}			10	ns
DACDAT setup time to BCLK rising edge	t _{DST}	10			ns
DACDAT hold time from BCLK rising edge	t _{DHT}	10			ns

AUDIO INTERFACE TIMING – SLAVE MODE

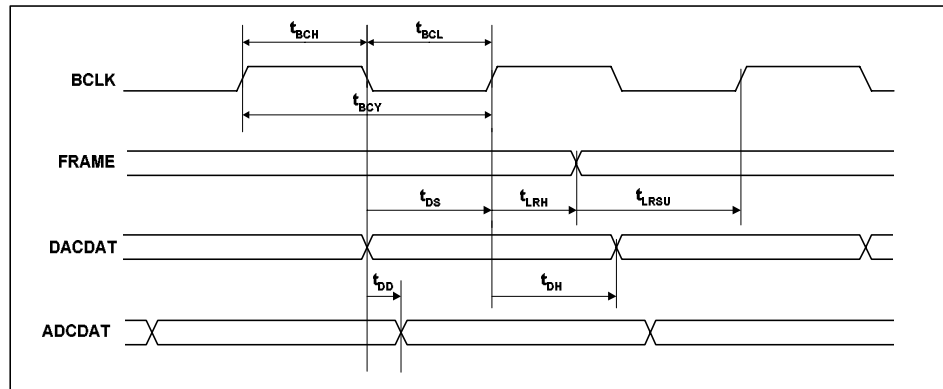

Figure 3 Digital Audio Data Timing – Slave Mode

Test Conditions

DCVDD=1.8V, DBVDD=AVDD=SPKVDD=3.3V, DGND=AGND=SPKGND=0V, TA=+25°C, Slave Mode, fs=48kHz, MCLK= 256fs, 24-bit data, unless otherwise stated.

PARAMETER	SYMBOL	MIN	TYP	MAX	UNIT
Audio Data Input Timing Information					
BCLK cycle time	t _{BCY}	50			ns
BCLK pulse width high	t _{BCH}	20			ns
BCLK pulse width low	t _{BCL}	20			ns
FRAME set-up time to BCLK rising edge	t _{LRSU}	10			ns
FRAME hold time from BCLK rising edge	t _{LRH}	10			ns
DACDAT hold time from BCLK rising edge	t _{DH}	10			ns
DACDAT set-up time to BCLK rising edge	t _{DS}			10	ns
ADCDAT propagation delay from BCLK falling edge	t _{DD}			20	ns

Note:

BCLK period should always be greater than or equal to MCLK period.

CONTROL INTERFACE TIMING – 3-WIRE MODE

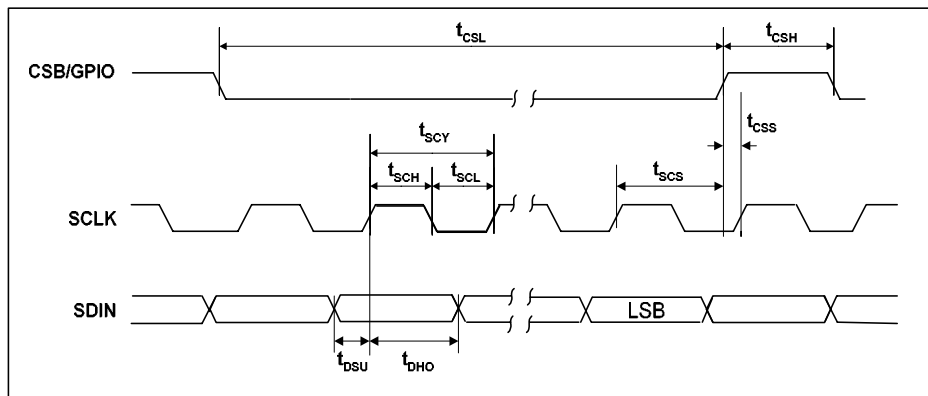

Figure 4 Control Interface Timing – 3-Wire Serial Control Mode

Test Conditions

DCVDD = 1.8V, DBVDD = AVDD = SPKVDD = 3.3V, DGND = AGND = SPKGND = 0V, T_A = +25°C, Slave Mode, f_s = 48kHz, MCLK = 256fs, 24-bit data, unless otherwise stated.

PARAMETER	SYMBOL	MIN	TYP	MAX	UNIT
Program Register Input Information					
SCLK rising edge to CSB rising edge	t _{SCS}	80			ns
SCLK pulse cycle time	t _{SCY}	200			ns
SCLK pulse width low	t _{SCL}	80			ns
SCLK pulse width high	t _{SCH}	80			ns
SDIN to SCLK set-up time	t _{DSU}	40			ns
SCLK to SDIN hold time	t _{DHO}	40			ns
CSB pulse width low	t _{CSL}	40			ns
CSB pulse width high	t _{CSH}	40			ns
CSB rising to SCLK rising	t _{CSS}	40			ns
Pulse width of spikes that will be suppressed	t _{ps}	0		5	ns

CONTROL INTERFACE TIMING – 2-WIRE MODE

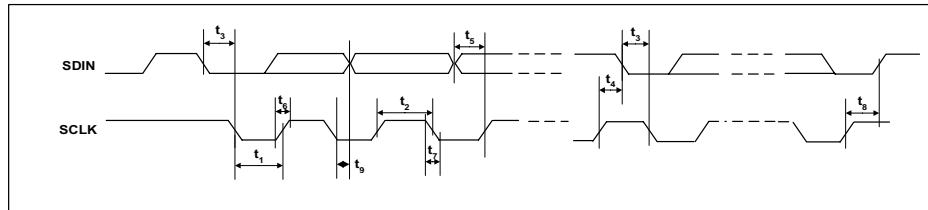

Figure 5 Control Interface Timing – 2-Wire Serial Control Mode

Test Conditions

DCVDD=1.8V, DBVDD=AVDD=SPKVDD=3.3V, DGND=AGND=SPKGND=0V, $T_A = +25^\circ\text{C}$, Slave Mode, $f_s = 48\text{kHz}$, MCLK = 256fs, 24-bit data, unless otherwise stated.

PARAMETER	SYMBOL	MIN	TYP	MAX	UNIT
Program Register Input Information					
SCLK Frequency		0		400	kHz
SCLK Low Pulse-Width	t_1	1.3			us
SCLK High Pulse-Width	t_2	600			ns
Hold Time (Start Condition)	t_3	600			ns
Setup Time (Start Condition)	t_4	600			ns
Data Setup Time	t_5	100			ns
SDIN, SCLK Rise Time	t_6			300	ns
SDIN, SCLK Fall Time	t_7			300	ns
Setup Time (Stop Condition)	t_8	600			ns
Data Hold Time	t_9			900	ns
Pulse width of spikes that will be suppressed	t_{ps}	0		5	ns

DEVICE DESCRIPTION

INTRODUCTION

The WM8974 is a low power audio codec combining a high quality mono audio DAC and ADC, with flexible line and microphone input and output processing. Applications for this device include digital still cameras with mono audio, record and playback capability, voice recorders, wireless VoIP headsets and games console accessories.

FEATURES

The chip offers great flexibility in use, and so can support many different modes of operation as follows:

MICROPHONE INPUTS

Two microphone inputs are provided, allowing for either a differential microphone input or a single ended microphone to be connected. These inputs have a user programmable gain range of -12dB to +35.25dB using internal resistors. After the input PGA stage comes a boost stage which can add a further 20dB of gain. A microphone bias is output from the chip which can be used to bias the microphones. The signal routing can be configured to allow manual adjustment of mic levels, or to allow the ALC loop to control the level of mic signal that is transmitted.

Total gain through the microphone paths of up to +55.25dB can be selected.

PGA AND ALC OPERATION

A programmable gain amplifier is provided in the input path to the ADC. This may be used manually or in conjunction with a mixed analogue/digital automatic level control (ALC) which keeps the recording volume constant.

AUX INPUT

The device includes a mono input, AUX, that can be used as an input for warning tones (beep) etc. The output from this circuit can be summed into the mono output and/or the speaker output paths, so allowing for mixing of audio with 'backing music' etc as required. This path can also be summed into the input in a flexible fashion, either to the input PGA as a second microphone input or as a line input. The configuration of this circuit, with integrated on-chip resistors allows several analogue signals to be summed into the single AUX input if required.

ADC

The mono ADC uses a multi-bit high-order oversampling architecture to deliver optimum performance with low power consumption. Various sample rates are supported, from the 8ks/s rate typically used in voice dictation, up to the 48ks/s rate used in high quality audio applications.

HI-FI DAC

The hi-fi DAC provides high quality audio playback suitable for all portable mono audio type applications.

DIGITAL FILTERING

Advanced Sigma Delta Converters are used along with digital decimation and interpolation filters to give high quality audio at sample rates from 8ks/s to 48ks/s.

Application specific digital filters are also available which help to reduce the effect of specific noise sources such as 'wind noise'. The filters include a programmable ADC high pass filter, a programmable ADC notch filter and a 5-band equaliser that can be applied to either the ADC or the DAC path in order to improve the overall audio sound from the device.

OUTPUT MIXING AND VOLUME ADJUST

Flexible mixing is provided on the outputs of the device; a mixer is provided for the speaker outputs, and an additional mono summer for the mono output. These mixers allow the output of the DAC, the output of the ADC volume control and the Auxilliary input to be combined. The output volume can be adjusted using the integrated digital volume control and there is additional analogue gain adjustment capability on the speaker output.

AUDIO INTERFACES

The WM8974 has a standard audio interface, to support the transmission of audio data to and from the chip. This interface is a 4 wire standard audio interface which supports a number of audio data formats including I²S, DSP Mode, MSB-First, left justified and MSB-First, right justified, and can operate in master or slave modes.

CONTROL INTERFACES

To allow full software control over all its features, the WM8974 offers a choice of 2 or 3 wire MPU control interface. It is fully compatible and an ideal partner for a wide range of industry standard microprocessors, controllers and DSPs. The selection between 2-wire mode and 3-wire mode is determined by the state of the MODE pin. If MODE is high then 3-wire control mode is selected, if MODE is low then 2-wire control mode is selected.

In 2 wire mode, only slave operation is supported, and the address of the device is fixed as 0011010.

CLOCKING SCHEMES

WM8974 offers the normal audio DAC clocking scheme operation, where 256fs MCLK is provided to the DAC/ADC.

However, a PLL is also included which may be used to generate the internal master clock frequency in the event that this is not available from the system controller. This PLL uses an input clock, typically the 12MHz USB or iLink clock, to generate high quality audio clocks. If this PLL is not required for generation of these clocks, it can be reconfigured to generate alternative clocks which may then be output on the CSB/GPIO pin and used elsewhere in the system.

POWER CONTROL

The design of the WM8974 has given much attention to power consumption without compromising performance. It operates at low supply voltages, and includes the facility to power off any unused parts of the circuitry under software control, includes standby and power off modes.

INPUT SIGNAL PATH

The WM8974 has 3 flexible analogue inputs: two microphone inputs, and an auxiliary input. These inputs can be used in a variety of ways. The input signal path before the ADC has a flexible PGA block which then feeds into a gain boost/mixer stage.

MICROPHONE INPUTS

The WM8974 can accommodate a variety of microphone configurations including single ended and differential inputs. The inputs through the MICN, MICP and optionally AUX pins are amplified through the input PGA as shown in Figure 6 .

A pseudo differential input is the preferential configuration where the positive terminal of the input PGA is connected to the MICP input pin by setting MICP2INPPGA=1. The microphone ground should then be connected to MICN (when MICN2INPPGA=1) or optionally to AUX (when AUX2INPPGA=1) input pins.

Alternatively a single ended microphone can be connected to the MICN input with MICN2INPPGA set to 1. The non-inverting terminal of the input PGA should be connected internally to VMID by setting MICP2INPPGA to 0.

In differential mode the larger signal should be input to MICP and the smaller (e.g. noisy ground connection) should be input to MICN.

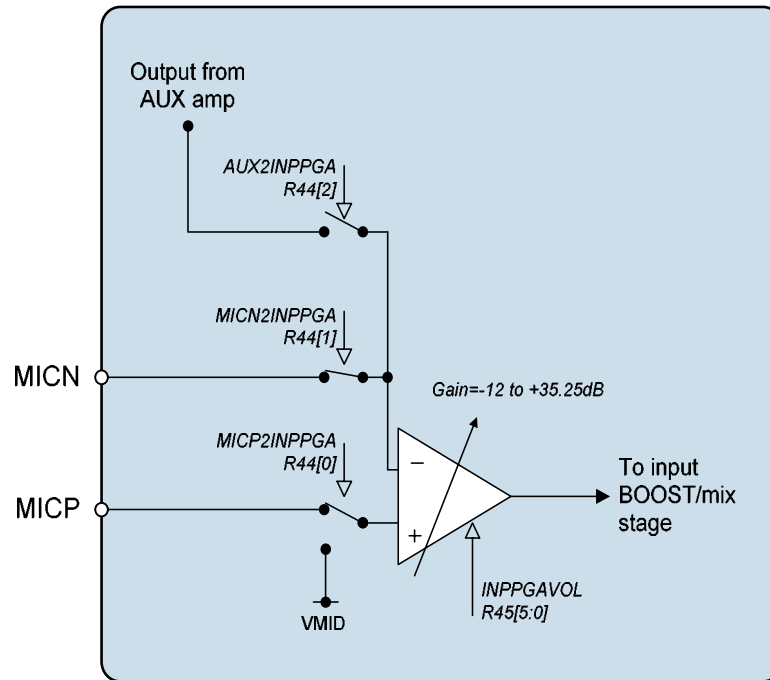

Figure 6 Microphone Input PGA Circuit (switch positions shown are for differential mic input)

REGISTER ADDRESS	BIT	LABEL	DEFAULT	DESCRIPTION
R44 Input Control	0	MICP2INPPGA	1	Connect input PGA amplifier positive terminal to MICP or VMID. 0 = input PGA amplifier positive terminal connected to VMID 1 = input PGA amplifier positive terminal connected to MICP through variable resistor string
	1	MICN2INPPGA	1	Connect MICN to input PGA negative terminal. 0=MICN not connected to input PGA 1=MICN connected to input PGA amplifier negative terminal.
	2	AUX2INPPGA	0	Select AUX amplifier output as input PGA signal source. 0=AUX not connected to input PGA 1=AUX connected to input PGA amplifier negative terminal.

The input PGA is enabled by the IPPGAEN register bit.

REGISTER ADDRESS	BIT	LABEL	DEFAULT	DESCRIPTION
R2 Power Management 2	2	INPPGAEN	0	Input microphone PGA enable 0 = disabled 1 = enabled

INPUT PGA VOLUME CONTROL

The input microphone PGA has a gain range from -12dB to +35.25dB in 0.75dB steps. The gain from the MICN input to the PGA output and from the AUX amplifier to the PGA output are always common and controlled by the register bits INPPGAVOL[5:0]. These register bits also affect the MICP pin when MICP2INPPGA=1.

When the Automatic Level Control (ALC) is enabled the input PGA gain is then controlled automatically and the INPPGAVOL bits should not be used.

REGISTER ADDRESS	BIT	LABEL	DEFAULT	DESCRIPTION
R45 Input PGA volume control	5:0	INPPGAVOL	010000	Input PGA volume 000000 = -12dB 000001 = -11.25db . 010000 = 0dB . 111111 = 35.25dB
	6	INPPGAMUTE	0	Mute control for input PGA: 0=Input PGA not muted, normal operation 1=Input PGA muted (and disconnected from the following input BOOST stage).
	7	INPPGAZC	0	Input PGA zero cross enable: 0=Update gain when gain register changes 1=Update gain on 1 st zero cross after gain register write.
R32 ALC control 1	8	ALCSEL	0	ALC function select: 0=ALC off (PGA gain set by INPPGAVOL register bits) 1=ALC on (ALC controls PGA gain)

Table 1 Input PGA Volume Control

AUXILLIARY INPUT

An auxilliary input circuit (Figure 7) is provided which consists of an amplifier which can be configured either as an inverting buffer for a single input signal or as a mixer/summer for multiple inputs with the use of external resistors. The circuit is enabled by the register bit AUXEN.

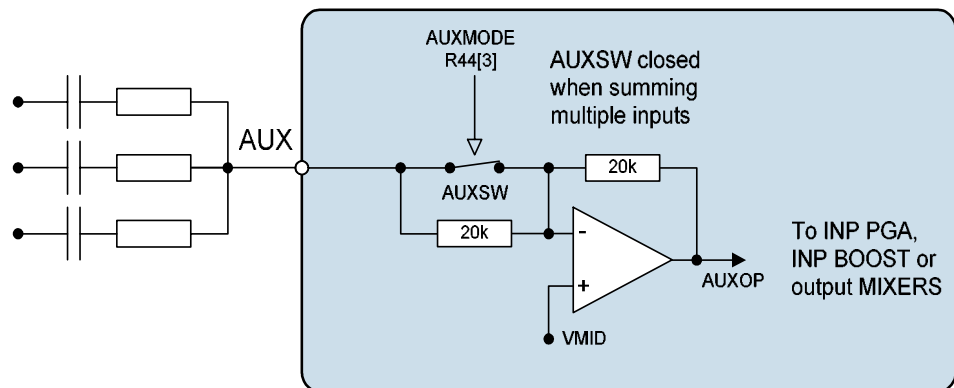

Figure 7 Auxiliary Input Circuit

The AUXMODE register bit controls the auxiliary input mode of operation:

In buffer mode (AUXMODE=0) the switch labelled AUXSW in Figure 7 is open and the signal at the AUX pin will be buffered and inverted through the aux circuit using only the internal components.

In mixer mode (AUXMODE=1) the on-chip input resistor is bypassed, this allows the user to sum in multiple inputs with the use of external resistors. When used in this mode there will be gain variations through this path from part to part due to the variation of the internal 20kΩ resistors relative to the higher tolerance external resistors.

REGISTER ADDRESS	BIT	LABEL	DEFAULT	DESCRIPTION
R1 Power management 1	6	AUXEN	0	Auxiliary input buffer enable 0 = OFF 1 = ON
R44 Input control	3	AUXMODE	0	0 = inverting buffer 1 = mixer (on-chip input resistor bypassed)

Table 2 Auxiliary Input Buffer Control

INPUT BOOST

The input BOOST circuit has 3 selectable inputs: the input microphone PGA output, the AUX amplifier output and the MICP input pin (when not using a differential microphone configuration). These three inputs can be mixed together and have individual gain boost/adjust as shown in Figure 8.

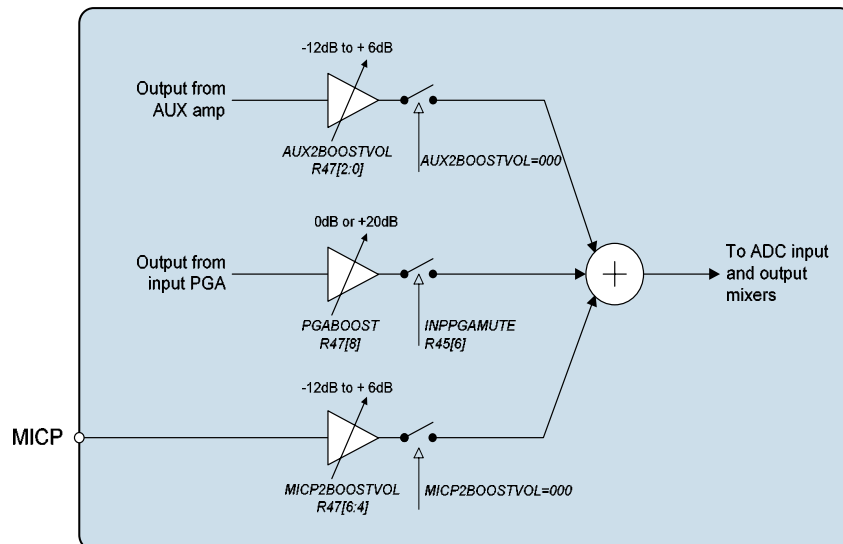

Figure 8 Input Boost Stage

The input PGA path can have a +20dB boost (PGABOOST=1) a 0dB pass through (PGABOOST=0) or be completely isolated from the input boost circuit (INPPGAMUTE=1).

REGISTER ADDRESS	BIT	LABEL	DEFAULT	DESCRIPTION
R45 Input PGA gain control	6	INPPGAMUTE	0	Mute control for input PGA: 0=Input PGA not muted, normal operation 1=Input PGA muted (and disconnected from the following input BOOST stage).
R47 Input BOOST control	8	PGABOOST	0	0 = PGA output has +0dB gain through input BOOST stage. 1 = PGA output has +20dB gain through input BOOST stage.

Table 3 Input BOOST Stage Control

The Auxiliary amplifier path to the BOOST stage is controlled by the AUX2BOOSTVOL[2:0] register bits. When AUX2BOOSTVOL=000 this path is completely disconnected from the BOOST stage. Settings 001 through to 111 control the gain in 3dB steps from -12dB to +6dB.

The MICP path to the BOOST stage is controlled by the MICP2BOOSTVOL[2:0] register bits. When MICP2BOOSTVOL=000 this input pin is completely disconnected from the BOOST stage. Settings 001 through to 111 control the gain in 3dB steps from -12dB to +6dB.

REGISTER ADDRESS	BIT	LABEL	DEFAULT	DESCRIPTION
R47 Input BOOST control	2:0	AUX2BOOSTVOL	000	Controls the auxiliary amplifier to the input boost stage: 000=Path disabled (disconnected) 001=-12dB gain through boost stage 010=-9dB gain through boost stage ... 111=+6dB gain through boost stage
	6:4	MICP2BOOSTVOL	000	Controls the MICP pin to the input boost stage (NB, when using this path set MICP2INPPGA=0): 000=Path disabled (disconnected) 001=-12dB gain through boost stage 010=-9dB gain through boost stage ... 111=+6dB gain through boost stage

Table 4 Input BOOST Stage Control

The BOOST stage is enabled under control of the BOOSTEN register bit.

REGISTER ADDRESS	BIT	LABEL	DEFAULT	DESCRIPTION
R2 Power management 2	4	BOOSTEN	0	Input BOOST enable 0 = Boost stage OFF 1 = Boost stage ON

Table 5 Input BOOST Enable Control

MICROPHONE BIASING CIRCUIT

The MICBIAS output provides a low noise reference voltage suitable for biasing electret type microphones and the associated external resistor biasing network. Refer to the Applications Information section for recommended external components. The MICBIAS voltage can be altered via the MBVSEL register bit. When MBVSEL=0, MICBIAS=0.9*AVDD and when MBVSEL=1, MICBIAS=0.65*AVDD. The output can be enabled or disabled using the MICBEN control bit.

REGISTER ADDRESS	BIT	LABEL	DEFAULT	DESCRIPTION
R1 Power management 1	4	MICBEN	0	Microphone Bias Enable 0 = OFF (high impedance output) 1 = ON

Table 6 Microphone Bias Enable

REGISTER ADDRESS	BIT	LABEL	DEFAULT	DESCRIPTION
R44 Input Control	8	MBVSEL	0	Microphone Bias Voltage Control 0 = 0.9 * AVDD 1 = 0.65 * AVDD

Table 7 Microphone Bias Voltage Control

The internal MICBIAS circuitry is shown in Figure 9. Note that the maximum source current capability for MICBIAS is 3mA. The external biasing resistors therefore must be large enough to limit the MICBIAS current to 3mA.

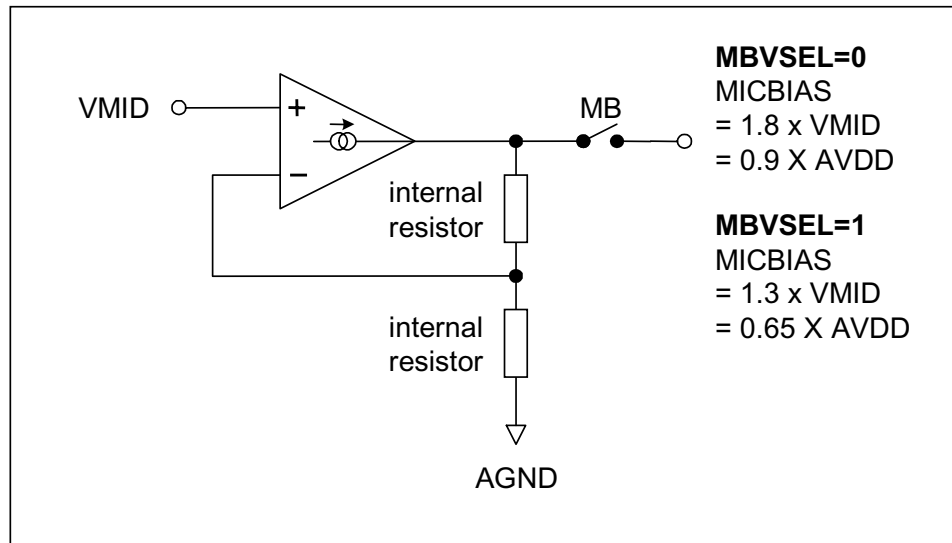

Figure 9 Microphone Bias Schematic

ANALOGUE TO DIGITAL CONVERTER (ADC)

The WM8974 uses a multi-bit, oversampled sigma-delta ADC channel. The use of multi-bit feedback and high oversampling rates reduces the effects of jitter and high frequency noise. The ADC Full Scale input level is proportional to AVDD. With a 3.3V supply voltage, the full scale level is 1.0V_{rms}. Any voltage greater than full scale may overload the ADC and cause distortion.

ADC DIGITAL FILTERS

The ADC filters perform true 24 bit signal processing to convert the raw multi-bit oversampled data from the ADC to the correct sampling frequency to be output on the digital audio interface. The digital filter path is illustrated in .

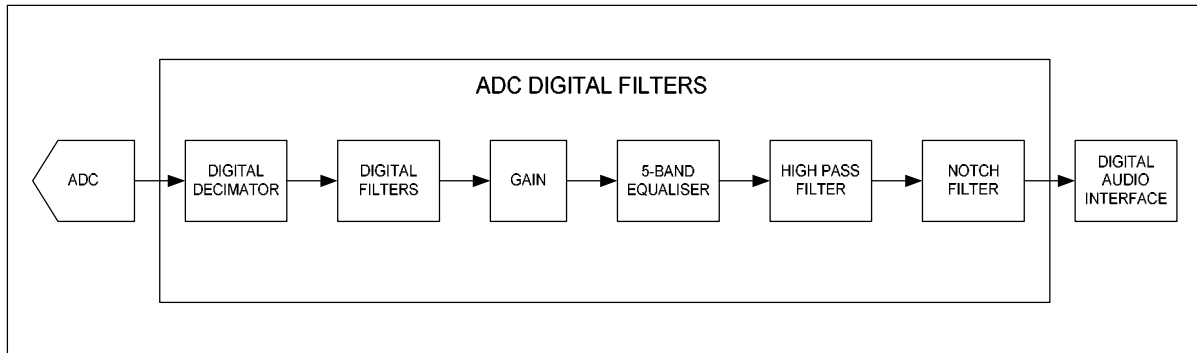

Figure 10 ADC Digital Filter Path

The ADC is enabled by the ADCEN register bit.

REGISTER ADDRESS	BIT	LABEL	DEFAULT	DESCRIPTION
R2 Power management 2	0	ADCEN	0	0 = ADC disabled 1 = ADC enabled

Table 8 ADC Enable

The polarity of the output signal can also be changed under software control using the ADCPOL register bit. The oversampling rate of the ADC can be adjusted using the ADCOSR register bit. With ADCOSR=0 the oversample rate is 64x which gives lowest power operation and when ADCOSR=1 the oversample rate is 128x which gives best performance.

REGISTER ADDRESS	BIT	LABEL	DEFAULT	DESCRIPTION
R14 ADC Control	3	ADCOSR	0	ADC oversample rate select: 0=64x (lower power) 1=128x (best performance)
	0	ADCPOL	0	0=normal 1=inverted

Table 9 ADC Oversample Rate Select

SELECTABLE HIGH PASS FILTER

A selectable high pass filter is provided. To disable this filter set HPFEN=0. The filter has two modes controlled by HPFAPP. In Audio Mode (HPFAPP=0) the filter is first order, with a cut-off frequency of 3.7Hz. In Application Mode (HPFAPP=1) the filter is second order, with a cut-off frequency selectable via the HPFCUT register. The cut-off frequencies when HPFAPP=1 are shown in Table 11.

REGISTER ADDRESS	BIT	LABEL	DEFAULT	DESCRIPTION
R14 ADC Control	8	HPFEN	1	High Pass Filter Enable 0=disabled 1=enabled
	7	HPFAPP	0	Select audio mode or application mode 0=Audio mode (1 st order, fc = ~3.7Hz) 1=Application mode (2 nd order, fc = HPFCUT)
	6:4	HPFCUT	000	Application mode cut-off frequency See Table 11 for details.

Table 10 ADC Filter Select

HPFCUT	FS (KHZ)								
	SR=101/100			SR=011/010			SR=001/000		
	8	11.025	12	16	22.05	24	32	44.1	48
000	82	113	122	82	113	122	82	113	122
001	102	141	153	102	141	153	102	141	153
010	131	180	156	131	180	156	131	180	156
011	163	225	245	163	225	245	163	225	245
100	204	281	306	204	281	306	204	281	306
101	261	360	392	261	360	392	261	360	392
110	327	450	490	327	450	490	327	450	490
111	408	563	612	408	563	612	408	563	612

Table 11 High Pass Filter Cut-off Frequencies (HPFAPP=1)

Note that the High Pass filter values (when HPFAPP=1) work on the basis that the SR register bits are set correctly for the actual sample rate as shown in Table 11.

PROGRAMMABLE NOTCH FILTER

A programmable notch filter is provided. This filter has a variable centre frequency and bandwidth, programmable via two coefficients, a0 and a1. a0 and a1 are represented by the register bits NFA0[13:0] and NFA1[13:0]. Because these coefficient values require four register writes to setup there is an NFU (Notch Filter Update) flag which should be set only when all four registers are setup.

REGISTER ADDRESS	BIT	LABEL	DEFAULT	DESCRIPTION
R27 Notch Filter 1	6:0	NFA0[13:7]	0	Notch Filter a0 coefficient, bits [13:7]
	7	NFEN	0	Notch filter enable: 0=Disabled 1=Enabled
	8	NFU	0	Notch filter update. The notch filter values used internally only update when one of the NFU bits is set high.
R28 Notch Filter 2	6:0	NFA0[6:0]	0	Notch Filter a0 coefficient, bits [6:0]
	8	NFU]	0	Notch filter update. The notch filter values used internally only update when one of the NFU bits is set high.
R29 Notch Filter 3	6:0	NFA1[13:7]	0	Notch Filter a1 coefficient, bits [13:7]
	8	NFU	0	Notch filter update. The notch filter values used internally only update when one of the NFU bits is set high.
R30 Notch Filter 4	6:0	NFA1[6:0]	0	Notch Filter a1 coefficient, bits [6:0]
	8	NFU	0	Notch filter update. The notch filter values used internally only update when one of the NFU bits is set high.

Table 12 Notch Filter Function

The coefficients are calculated as follows:

$$a_0 = \frac{1 - \tan(w_b / 2)}{1 + \tan(w_b / 2)}$$

$$a_1 = -(1 + a_0) \cos(w_0)$$

Where:

$$w_0 = 2\pi f_c / f_s$$

$$w_b = 2\pi f_b / f_s$$

f_c = centre frequency in Hz, f_b = -3dB bandwidth in Hz, f_s = sample frequency in Hz

The actual register values can be determined from the coefficients as follows:

$$\text{NFA0} = -a_0 \times 2^{13}$$

$$\text{NFA1} = -a_1 \times 2^{12}$$

DIGITAL ADC VOLUME CONTROL

The output of the ADCs can be digitally attenuated over a range from -127dB to 0dB in 0.5dB steps. The gain for a given eight-bit code X is given by:

$$\text{Gain} = 0.5 \times (x-255) \text{ dB for } 1 \leq x \leq 255, \text{ MUTE for } x = 0$$

REGISTER ADDRESS	BIT	LABEL	DEFAULT	DESCRIPTION
R15 ADC Digital Volume	7:0	ADCVOL [7:0]	11111111 (0dB)	ADC Digital Volume Control 0000 0000 = Digital Mute 0000 0001 = -127dB 0000 0010 = -126.5dB ... 0.5dB steps up to 1111 1111 = 0dB

Table 13 ADC Volume

INPUT AUTOMATIC LEVEL CONTROL (ALC)

The Automatic Level Control (ALC) provides continuous adjustment of the input PGA in response to the amplitude of the input signal. A digital peak detector monitors the input signal amplitude and compares it to a register defined threshold level (ALCLVL).

ALCLVL	Threshold level (dB)
0000	reserved
0001	-1.5
0010	-3
0011	-4.5
0100	-6
0101	-7.5
0110	-9
0111	-10.5
1000	-12
1001	-13.5
1010	-15
1011	-16.5
1100	-18
1101	-19.5
1110	-21
1111	-22.5

Table 14 ALC Threshold

If the signal is below the threshold, the ALC will increase the gain of the PGA at a rate set by ALDCY. If the signal is above the threshold, the ALC will reduce the gain of the PGA at a rate set by ALCATK.

The ALC has two modes selected by the ALCMODE register: normal mode and peak limiter mode. The ALC is enabled by setting ALCSEL to 1.

REGISTER ADDRESS	BIT	LABEL	DEFAULT	DESCRIPTION
R32 ALC Control 1	8	ALCSEL	0	ALC function select 0=ALC disabled 1=ALC enabled
R33 ALC Control 2	3:0	ALCLVL	1011	ALC threshold level. Sets the desired signal level.
R34 ALC Control 3	8	ALCMODE	0	Determines the ALC mode of operation: 0=ALC mode 1=Limiter mode.
	7:4	ALCDCY	0011	Decay (gain ramp-up) time
	3:0	ALCATK	0010	ALC attack (gain ramp-down) time

Table 15 ALC Control

NORMAL MODE

In normal mode, the ALC will attempt to maintain a constant signal level by increasing or decreasing the gain of the PGA. The following diagram shows an example of this.

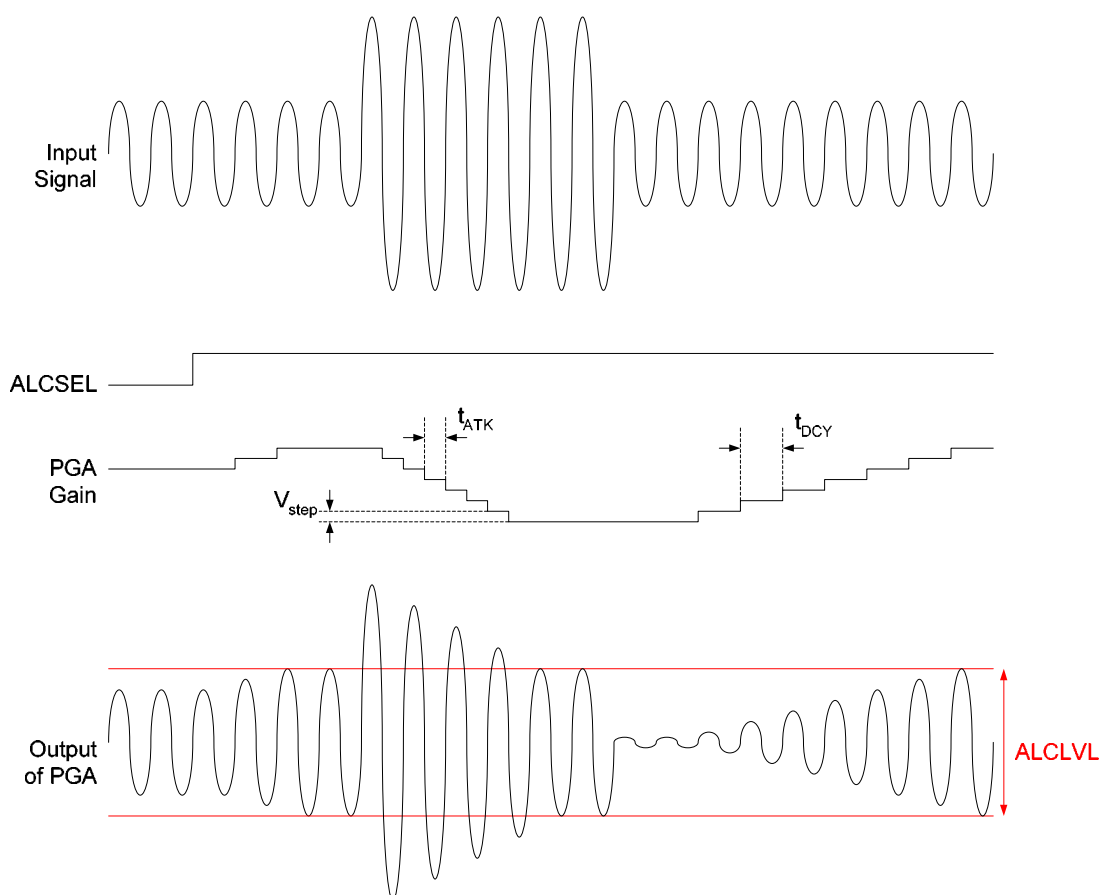

Figure 11 ALC Normal Mode Operation

LIMITER MODE

In limiter mode, the ALC will reduce peaks that go above the threshold level, but will not increase the PGA gain beyond the starting level. The starting level is the PGA gain setting when the ALC is enabled in limiter mode. If the ALC is started in limiter mode, this is the gain setting of the PGA at startup. If the ALC is switched into limiter mode after running in ALC mode, the starting gain will be the gain at switchover. The diagram below shows an example of limiter mode.

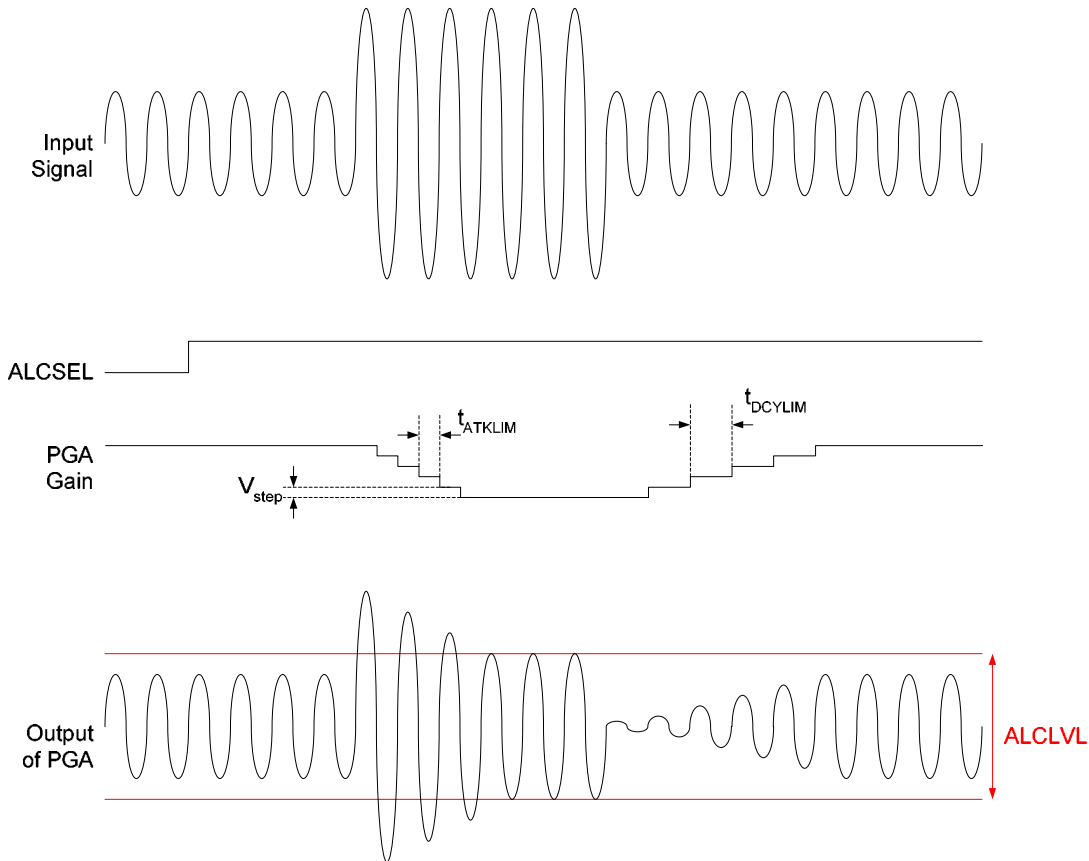

Figure 12 ALC Limiter Mode Operation

ATTACK AND DECAY TIMES

The attack and decay times set the update times for the PGA gain. The attack time is the time constant used when the gain is reducing. The decay time is the time constant used when the gain is increasing. In limiter mode, the time constants are faster than in ALC mode. The time constants are shown below in terms of a single gain step, a change of 6dB and a change of 90% of the PGAs gain range.

Note that, these times will vary slightly depending on the sample rate used (specified by the SR register).

NORMAL MODE

ALCMODE = 0 (Normal Mode)			
Attack Time (s)			
ALCATK	t _{ATK}	t _{ATK6dB}	t _{ATK90%}
0000	1.04E-04	8.32E-04	5.99E-03
0001	2.08E-04	1.66E-03	1.20E-02
0010	4.16E-04	3.33E-03	2.40E-02
0011	8.32E-04	6.66E-03	4.79E-02
0100	1.66E-03	1.33E-02	9.58E-02
0101	3.33E-03	2.66E-02	1.92E-01
0110	6.66E-03	5.32E-02	3.83E-01
0111	1.33E-02	1.06E-01	7.67E-01
1000	2.66E-02	2.13E-01	1.53E+00
1001	5.32E-02	4.26E-01	3.07E+00
1010	1.06E-01	8.52E-01	6.13E+00

ALCMODE = 0 (Normal Mode)			
Decay Time (s)			
ALCDCY	t _{DCY}	t _{DCY6dB}	t _{DCY90%}
0000	4.10E-04	3.28E-03	2.36E-02
0001	8.20E-04	6.56E-03	4.72E-02
0010	1.64E-03	1.31E-02	9.45E-02
0011	3.28E-03	2.62E-02	1.89E-01
0100	6.56E-03	5.25E-02	3.78E-01
0101	1.31E-02	1.05E-01	7.56E-01
0110	2.62E-02	2.10E-01	1.51E+00
0111	5.25E-02	4.20E-01	3.02E+00
1000	1.05E-01	8.40E-01	6.05E+00
1001	2.10E-01	1.68E+00	1.21E+01
1010	4.20E-01	3.36E+00	2.42E+01

Table 16 ALC Normal Mode

LIMITER MODE

ALCMODE = 1 (Limiter Mode)			
Attack Time (s)			
ALCATK	t _{ATKLIM}	t _{ATKLIM6dB}	t _{ATKLIM90%}
0000	2.27E-05	1.82E-04	1.31E-03
0001	4.54E-05	3.63E-04	2.62E-03
0010	9.08E-05	7.26E-04	5.23E-03
0011	1.82E-04	1.45E-03	1.05E-02
0100	3.63E-04	2.91E-03	2.09E-02
0101	7.26E-04	5.81E-03	4.18E-02
0110	1.45E-03	1.16E-02	8.37E-02
0111	2.91E-03	2.32E-02	1.67E-01
1000	5.81E-03	4.65E-02	3.35E-01
1001	1.16E-02	9.30E-02	6.69E-01
1010	2.32E-02	1.86E-01	1.34E+00

ALCMODE = 1 (Limiter Mode)			
Attack Time (s)			
ALCATK	t _{ATKLIM}	t _{ATKLIM6dB}	t _{ATKLIM90%}
0000	2.27E-05	1.82E-04	1.31E-03
0001	4.54E-05	3.63E-04	2.62E-03
0010	9.08E-05	7.26E-04	5.23E-03
0011	1.82E-04	1.45E-03	1.05E-02
0100	3.63E-04	2.91E-03	2.09E-02
0101	7.26E-04	5.81E-03	4.18E-02
0110	1.45E-03	1.16E-02	8.37E-02
0111	2.91E-03	2.32E-02	1.67E-01
1000	5.81E-03	4.65E-02	3.35E-01
1001	1.16E-02	9.30E-02	6.69E-01
1010	2.32E-02	1.86E-01	1.34E+00

Table 17 ALC Limiter Mode

MAXIMUM AND MINIMUM GAIN

The operating gain range of the ALC can be set using the ALCMAX and ALCMIN registers.

REGISTER ADDRESS	BIT	LABEL	DEFAULT	DESCRIPTION
R32	5:3	ALCMAX	111	Set Maximum Gain of PGA
ALC Control 1	2:0	ALCMIN	000	Set minimum gain of PGA

Table 18 ALC Max/Min Gain

In normal mode, ALCMAX sets the maximum boost which can be applied to the signal. In limiter mode, ALCMAX will normally have no effect (assuming the starting gain value is less than the maximum gain specified by ALCMAX) because the maximum gain is set at the starting gain level.

ALCMIN sets the minimum gain value which can be applied to the signal.

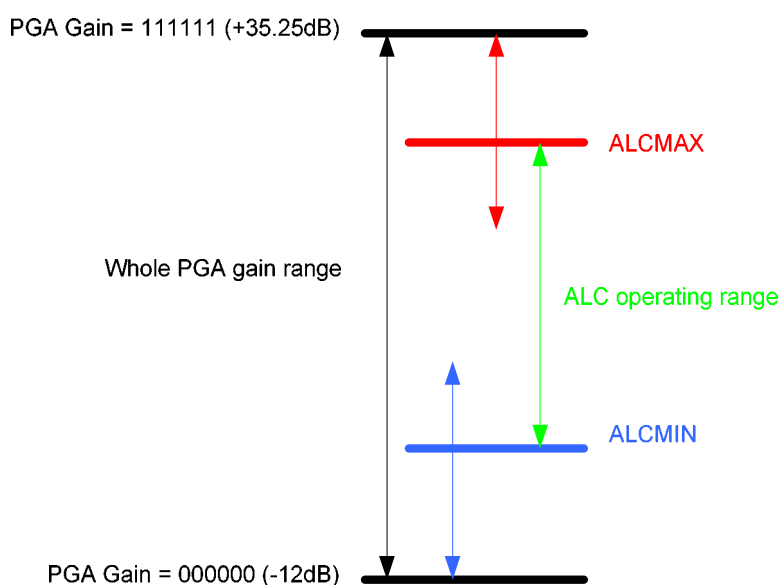

Figure 13 ALC Min/Max Gain

ALCMAX	Maximum Gain (dB)
111	35.25
110	29.25
101	23.25
100	17.25
011	11.25
010	5.25
001	-0.75
000	-6.75

Table 19 ALC Max Gain Values

ALCMIN	Minimum Gain (dB)
000	-12
001	-6
010	0
011	6
100	12
101	18
110	24
111	30

Table 20 ALC Min Gain Values

Note that if the ALC gain setting strays outside the ALC operating range, either by starting the ALC outside of the range or changing the ALCMAX or ALCMIN settings during operation, the ALC will immediately adjust the gain to return to the ALC operating range. It is recommended that the ALC starting gain is set between the ALCMAX and ALCMIN limits.

ALC HOLD TIME (NORMAL MODE ONLY)

In Normal mode, the ALC has an adjustable hold time which sets a time delay before the ALC begins its decay phase (gain increasing). The hold time is set by the ALCHLD register.

REGISTER ADDRESS	BIT	LABEL	DEFAULT	DESCRIPTION
R33 ALC Control 2	7:4	ALCHLD	0000	ALC hold time before gain is increased.

Table 21 ALC Hold Time

If the hold time is exceeded this indicates that the signal has reached a new average level and the ALC will increase the gain to adjust for that new average level. If the signal goes above the threshold during the hold period, the hold phase is abandoned and the ALC returns to normal operation.

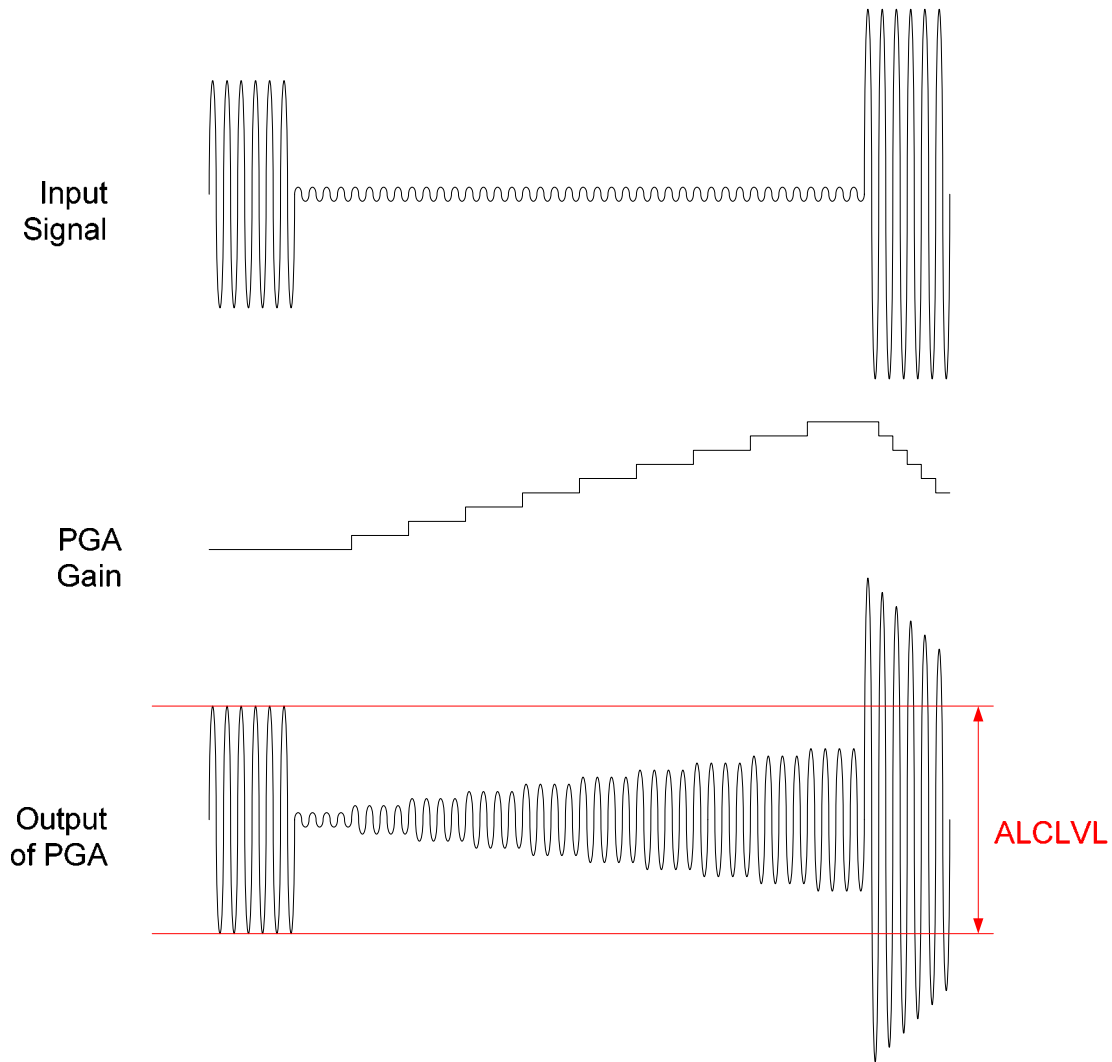

Figure 14 ALCLVL

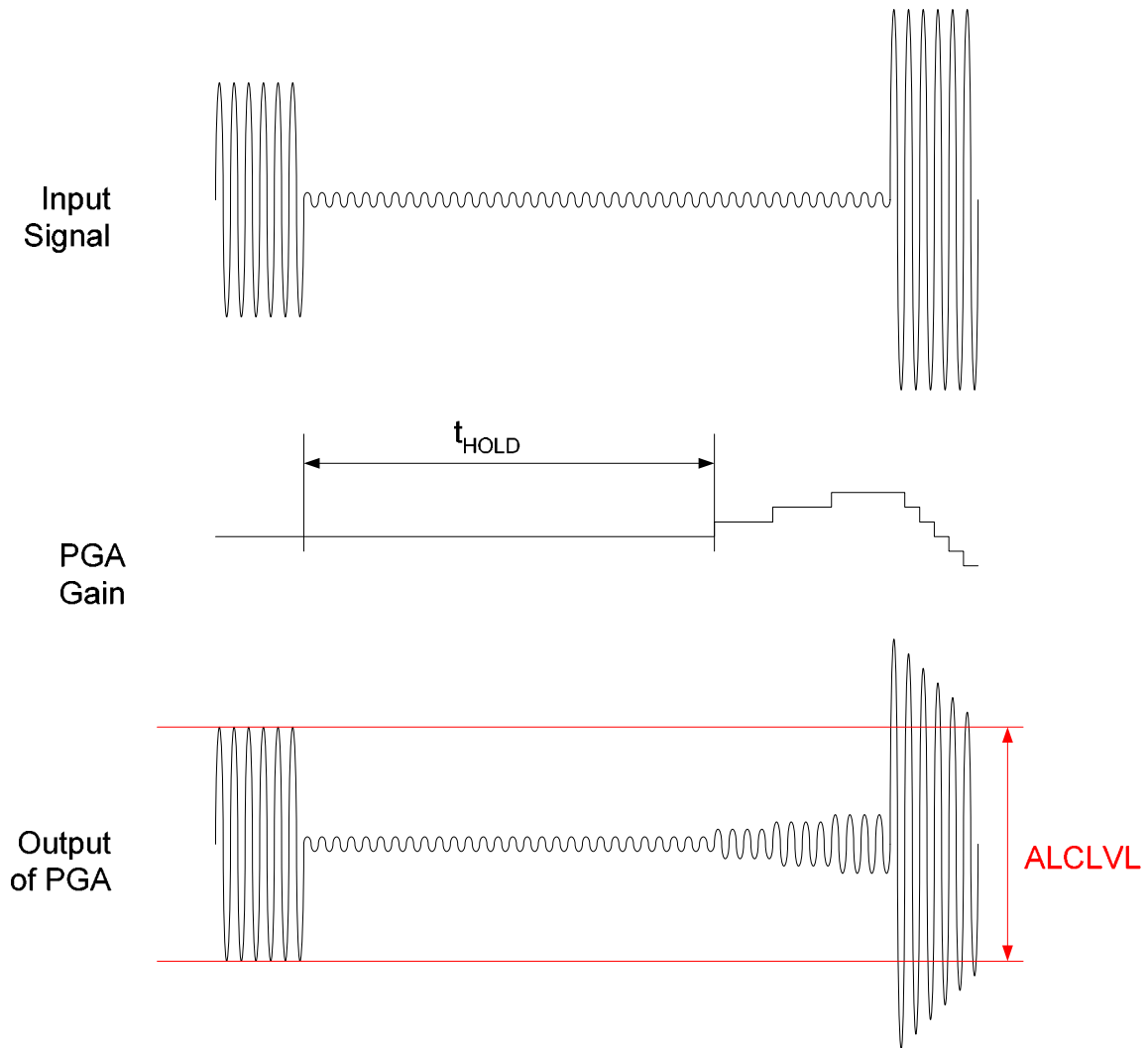

Figure 15 ALC Hold Time

ALCHLD	t_{HOLD} (s)
0000	0
0001	2.67E-03
0010	5.34E-03
0011	1.07E-02
0100	2.14E-02
0101	4.27E-02
0110	8.54E-02
0111	1.71E-01
1000	3.42E-01
1001	6.84E-01
1010	1.37E+00

Table 22 ALC Hold Time Values

ALC CLIP PROTECTION (NORMAL MODE ONLY)

In normal mode, the ALC has a clip protection circuit which allows the circuit to reduce the gain more quickly in response to large input signals. The clip protection circuit operates when the signal level goes above -1dB. When this happens the gain is reduced at the fastest possible rate (as when ALCATK = 0000) until the signal falls below -1dB at which point normal operation is resumed.

NOISE GATE (NORMAL MODE ONLY)

The noise gate stops the ALC from increasing the gain during periods of silence in the signal which would amplify the noise in the signal and possibly cause the signal to clip when it is reapplied.

The noise gate detects when the input signal level goes below a defined threshold (NGTH). If the signal is below the threshold, the noise gate is activated and the gain is held constant.

REGISTER ADDRESS	BIT	LABEL	DEFAULT	DESCRIPTION
R35 ALC Noise Gate Control	2:0	NGTH	000	Noise gate threshold:
	3	NGEN	0	Noise gate function enable 1 = enable 0 = disable

Table 23 Noise Gate Control

NGTH	Threshold (dB)
000	-39
001	-45
010	-51
011	-57
100	-63
101	-69
110	-75
111	-81

Table 24 Noise Gate Threshold

The diagrams below show the response of the system to the same signal with and without noise gate.

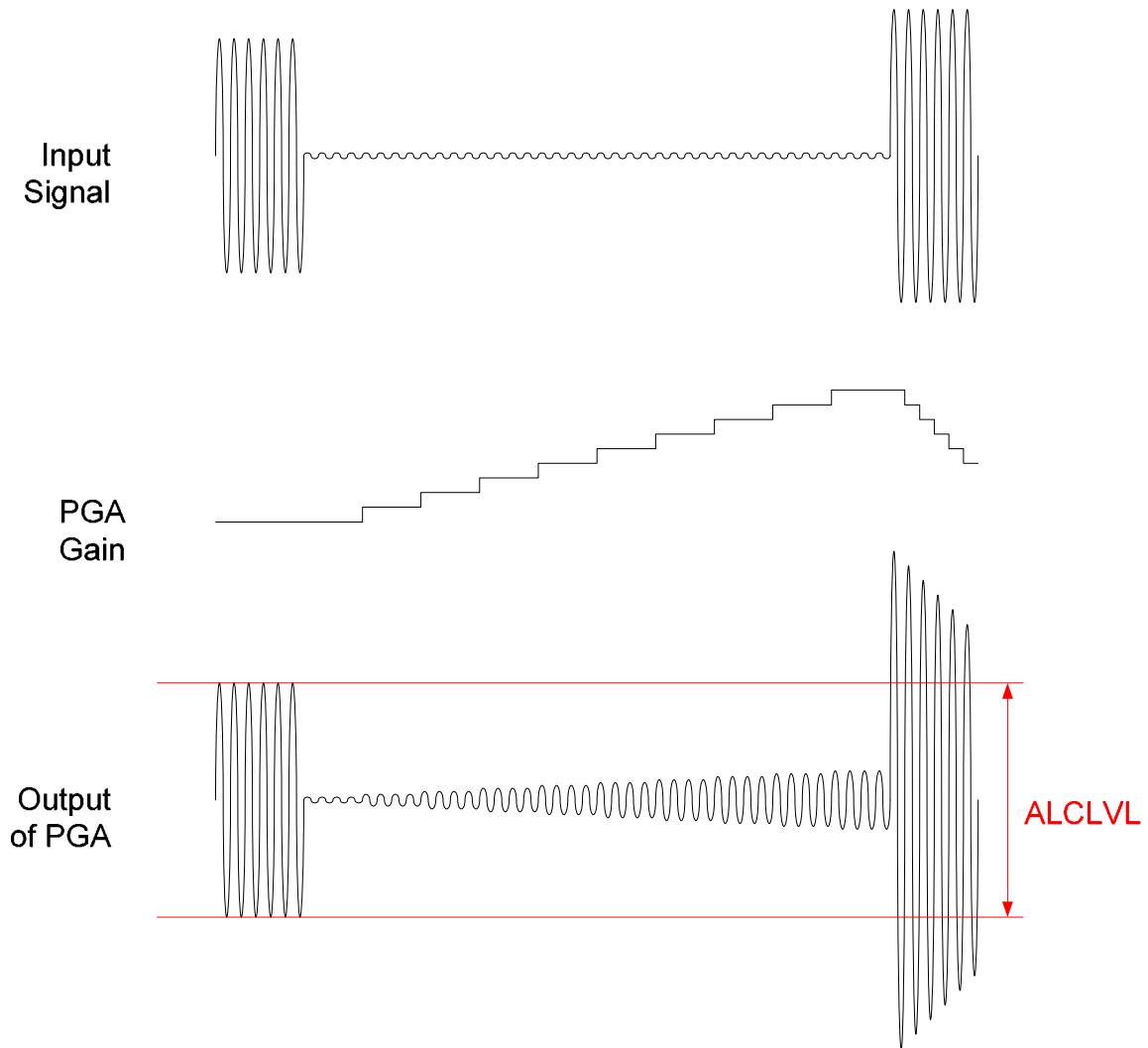

Figure 16 ALC Operation Above Noise Gate Threshold

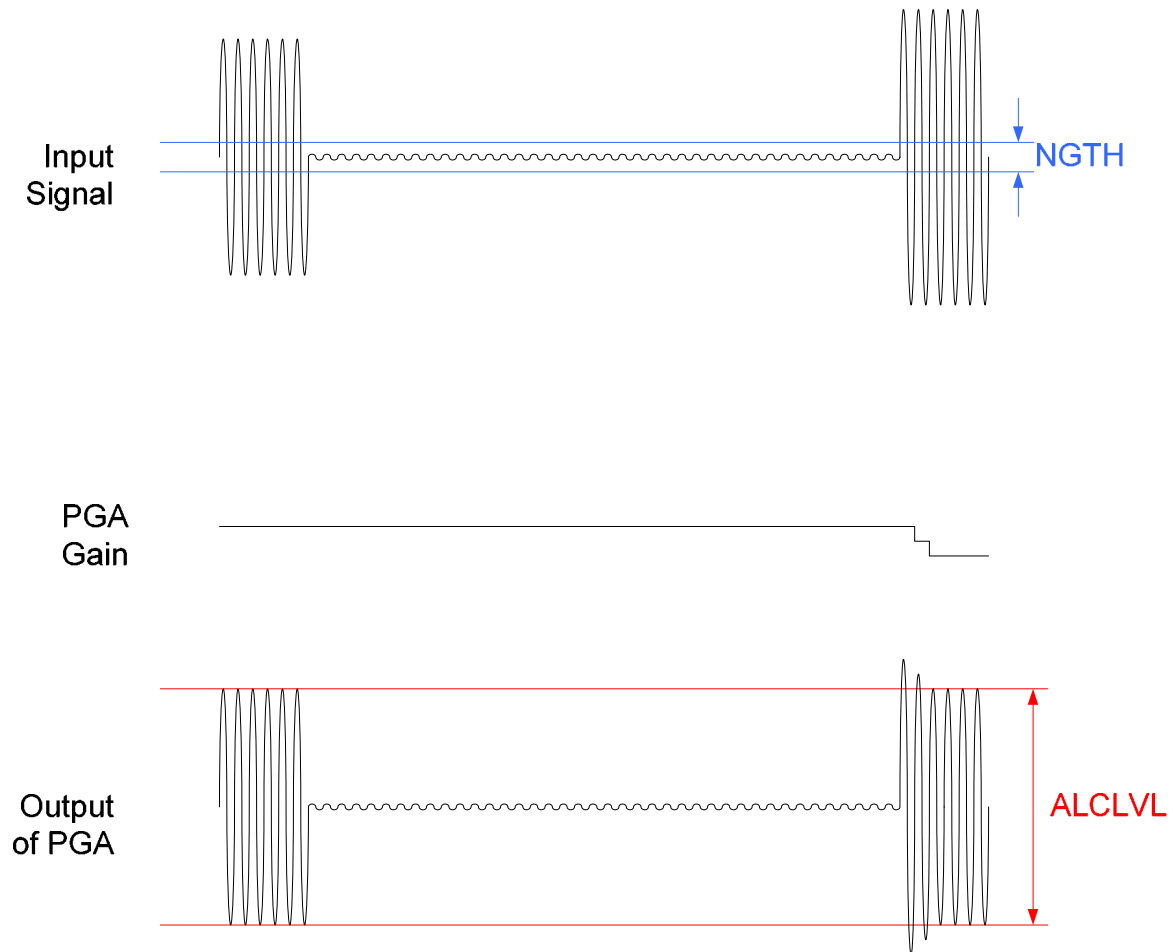

Figure 17 Noise Gate Operation

OUTPUT SIGNAL PATH

The WM8974 output signal paths consist of digital application filters, up-sampling filters, a Hi-Fi DAC, analogue mixers, speaker and mono output drivers. The digital filters and DAC are enabled by bit DACEN. The mixers and output drivers can be separately enabled by individual control bits (see Analogue Outputs). Thus it is possible to utilise the analogue mixing and amplification provided by the WM8974, irrespective of whether the DACs are running or not.

The WM8974 DAC receives digital input data on the DACDAT pin. The digital filter block processes the data to provide the following functions:

- § Digital volume control
- § Graphic equaliser
- § A digital peak limiter.
- § Sigma-Delta Modulation

The high performance sigma-delta audio DAC converts the digital data into an analogue signal.

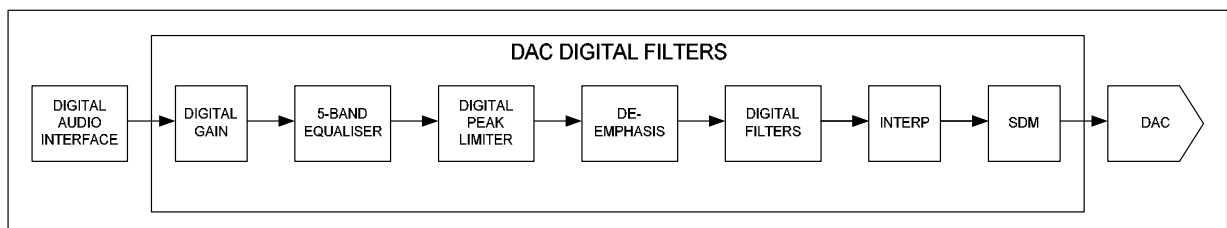

Figure 18 DAC Digital Filter Path

The analogue output from the DAC can then be mixed with the AUX analogue input and the ADC analogue input. The mix is fed to the output drivers, SPKOUTP/N, and MONOOUT.

MONOOUT: can drive a 16Ω or 32Ω headphone or line output or can be a buffered version of VMID (When MONOMUTE=1).

SPKOUTP/N: can drive a 16Ω or 32Ω stereo headphone or stereo line output, or an 8Ω BTL mono speaker.

DIGITAL HI-FI DAC VOLUME CONTROL

The signal volume from each Hi-Fi DAC can be controlled digitally. The gain and attenuation range is -127dB to 0dB in 0.5dB steps. The level of attenuation for an eight-bit code X is given by:

$$0.5 \times (X-255) \text{ dB for } 1 \leq X \leq 255; \quad \text{MUTE for } X = 0$$

REGISTER ADDRESS	BIT	LABEL	DEFAULT	DESCRIPTION
R11 DAC Digital Volume	7:0	DACVOL [7:0]	11111111 (0dB)	DAC Digital Volume Control 0000 0000 = Digital Mute 0000 0001 = -127dB 0000 0010 = -126.5dB ... 0.5dB steps up to 1111 1111 = 0dB

Table 25 DAC Volume

HI-FI DIGITAL TO ANALOGUE CONVERTER (DAC)

After passing through the graphic equaliser filters, digital 'de-emphasis' can be applied to the audio data if necessary (e.g. when the data comes from a CD with pre-emphasis used in the recording). De-emphasis filtering is available for sample rates of 48kHz, 44.1kHz and 32kHz.

REGISTER ADDRESS	BIT	LABEL	DEFAULT	DESCRIPTION
R10 DAC Control	5:4	DEEMPH	00	De-Emphasis Control 00 = No de-emphasis 01 = 32kHz sample rate 10 = 44.1kHz sample rate 11 = 48kHz sample rate

Table 26 De-Emphasis

The DAC is enabled by the DACEN register bit.

REGISTER ADDRESS	BIT	LABEL	DEFAULT	DESCRIPTION
R3 Power Management 3	0	DACEN	0	DAC enable 0 = DAC disabled 1 = DAC enabled

Table 27 DAC Enable

The WM8974 also has a Soft Mute function, which gradually attenuates the volume of the digital signal to zero. When removed, the gain will ramp back up to the digital gain setting. This function is enabled by default. To play back an audio signal, it must first be disabled by setting the DACMU bit to zero.

REGISTER ADDRESS	BIT	LABEL	DEFAULT	DESCRIPTION
R10 DAC Control	6	DACMU	0	DAC soft mute enable 0 = DACMU disabled 1 = DACMU enabled

Table 28 DAC Control Register

The digital audio data is converted to oversampled bit streams in the on-chip, true 24-bit digital interpolation filters. The bitstream data enters a multi-bit, sigma-delta DAC, which converts it to a high quality analogue audio signal. The multi-bit DAC architecture reduces high frequency noise and sensitivity to clock jitter.

The DAC output defaults to non-inverted. Setting DACPOL will invert the DAC output phase.

AUTOMUTE

The DAC has an automute function which applies an analogue mute when 1024 consecutive zeros are detected. The mute is release as soon as a non-zero sample is detected. Automute can be disabled using the AMUTE control bit.

REGISTER ADDRESS	BIT	LABEL	DEFAULT	DESCRIPTION
R10 DAC Control	2	AMUTE	0	DAC auto mute enable 0 = auto mute disabled 1 = auto mute enabled

Table 29 DAC Auto Mute Control Register

DAC OUTPUT LIMITER

The WM8974 has a digital output limiter function. The operation of this is shown in Figure 19. In this diagram the upper graph shows the envelope of the input/output signals and the lower graph shows the gain characteristic.

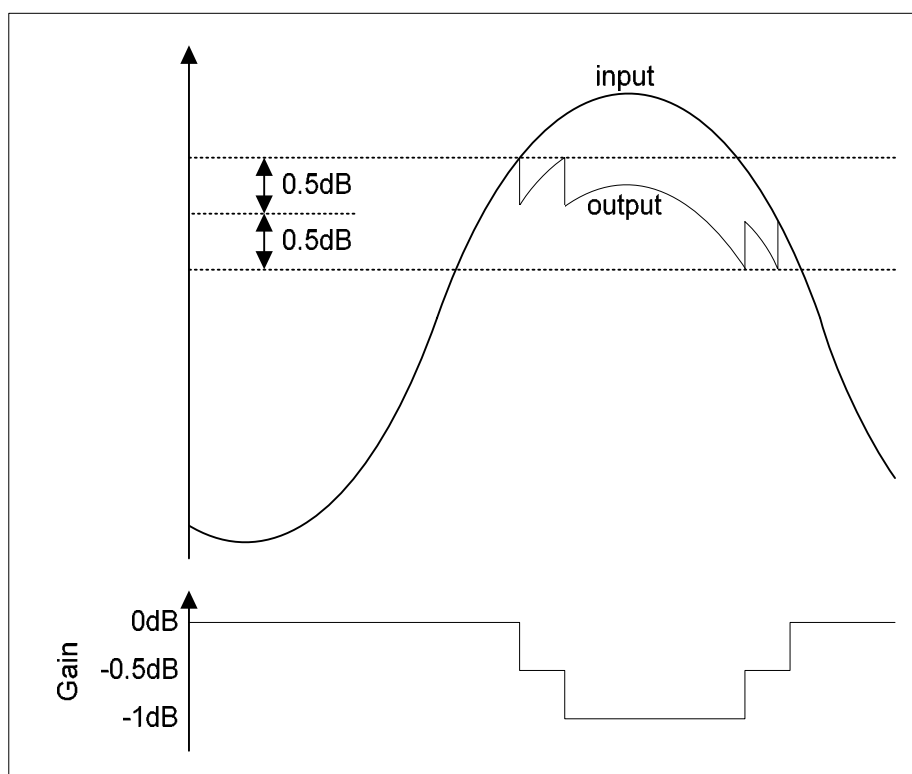

Figure 19 DAC Digital Limiter Operation

The limiter has a programmable upper threshold which is close to 0dB. Referring to Table 30, in normal operation (LIMBOOST=000 => limit only) signals below this threshold are unaffected by the limiter. Signals above the upper threshold are attenuated at a specific attack rate (set by the LIMATK register bits) until the signal falls below the threshold. The limiter also has a lower threshold 1dB below the upper threshold. When the signal falls below the lower threshold the signal is amplified at a specific decay rate (controlled by LIMDCY register bits) until a gain of 0dB is reached. Both threshold levels are controlled by the LIMLVL register bits. The upper threshold is 0.5dB above the value programmed by LIMLVL and the lower threshold is 0.5dB below the LIMLVL value.

VOLUME BOOST

The limiter has programmable upper gain which boosts signals below the threshold to compress the dynamic range of the signal and increase its perceived loudness. This operates as an ALC function with limited boost capability. The volume boost is from 0dB to +12dB in 1dB steps, controlled by the LIMBOOST register bits.

The output limiter volume boost can also be used as a stand alone digital gain boost when the limiter is disabled.

REGISTER ADDRESS	BIT	LABEL	DEFAULT	DESCRIPTION
R24 DAC digital limiter control 1	3:0	LIMATK	0010	Limiter Attack time (per 6dB gain change) for 44.1kHz sampling. Note that these will scale with sample rate. 0000=94us 0001=188s 0010=375us 0011=750us 0100=1.5ms 0101=3ms 0110=6ms 0111=12ms 1000=24ms 1001=48ms 1010=96ms 1011 to 1111=192ms
	7:4	LIMDCY	0011	Limiter Decay time (per 6dB gain change) for 44.1kHz sampling. Note that these will scale with sample rate: 0000=750us 0001=1.5ms 0010=3ms 0011=6ms 0100=12ms 0101=24ms 0110=48ms 0111=96ms 1000=192ms 1001=384ms 1010=768ms 1011 to 1111=1.536s
	8	LIMEN	0	Enable the DAC digital limiter: 0=disabled 1=enabled
R25 DAC digital limiter control 2	3:0	LIMBOOST	0000	Limiter volume boost (can be used as a stand alone volume boost when LIMEN=0): 0000=0dB 0001=+1dB 0010=+2dB ... (1dB steps) 1011=+11dB 1100=+12dB 1101 to 1111=reserved
	6:4	LIMLVL	000	Programmable signal threshold level (determines level at which the limiter starts to operate) 000=-1dB 001=-2dB 010=-3dB 011=-4dB 100=-5dB 101 to 111=-6dB

Table 30 DAC Digital Limiter Control

GRAPHIC EQUALISER

A 5-band graphic EQ is provided, which can be applied to the ADC or DAC path under control of the EQMODE register bit.

REGISTER ADDRESS	BIT	LABEL	DEFAULT	DESCRIPTION
R18 EQ Control 1	8	EQMODE	1	0 = Equaliser applied to ADC path 1 = Equaliser applied to DAC path

Table 31 EQ DAC or ADC Path Select

The equaliser consists of low and high frequency shelving filters (Band 1 and 5) and three peak filters for the centre bands. Each has adjustable cut-off or centre frequency, and selectable boost (+/- 12dB in 1dB steps). The peak filters have selectable bandwidth.

REGISTER ADDRESS	BIT	LABEL	DEFAULT	DESCRIPTION
R18 EQ Band 1 Control	4:0	EQ1G	01100 (0dB)	Band 1 Gain Control. See Table 37 for details.
	6:5	EQ1C	01	Band 1 Cut-off Frequency: 00=80Hz 01=105Hz 10=135Hz 11=175Hz

Table 32 EQ Band 1 Control

REGISTER ADDRESS	BIT	LABEL	DEFAULT	DESCRIPTION
R19 EQ Band 2 Control	4:0	EQ2G	01100 (0dB)	Band 2 Gain Control. See Table 37 for details.
	6:5	EQ2C	01	Band 2 Centre Frequency: 00=230Hz 01=300Hz 10=385Hz 11=500Hz
	8	EQ2BW	0	Band 2 Bandwidth Control 0=narrow bandwidth 1=wide bandwidth

Table 33 EQ Band 2 Control

REGISTER ADDRESS	BIT	LABEL	DEFAULT	DESCRIPTION
R20 EQ Band 3 Control	4:0	EQ3G	01100 (0dB)	Band 3 Gain Control. See Table 37 for details.
	6:5	EQ3C	01	Band 3 Centre Frequency: 00=650Hz 01=850Hz 10=1.1kHz 11=1.4kHz
	8	EQ3BW	0	Band 3 Bandwidth Control 0=narrow bandwidth 1=wide bandwidth

Table 34 EQ Band 3 Control

REGISTER ADDRESS	BIT	LABEL	DEFAULT	DESCRIPTION
R21 EQ Band 4 Control	4:0	EQ4G	01100 (0dB)	Band 4 Gain Control. See Table 37 for details
	6:5	EQ4C	01	Band 4 Centre Frequency: 00=1.8kHz 01=2.4kHz 10=3.2kHz 11=4.1kHz
	8	EQ4BW	0	Band 4 Bandwidth Control 0=narrow bandwidth 1=wide bandwidth

Table 35 EQ Band 4 Control

REGISTER ADDRESS	BIT	LABEL	DEFAULT	DESCRIPTION
R22 EQ Band 5 Gain Control	4:0	EQ5G	01100 (0dB)	Band 5 Gain Control. See Table 37 for details.
	6:5	EQ5C	01	Band 5 Cut-off Frequency: 00=5.3kHz 01=6.9kHz 10=9kHz 11=11.7kHz

Table 36 EQ Band 5 Control

GAIN REGISTER	GAIN
00000	+12dB
00001	+11dB
00010	+10dB
.... (1dB steps)	
01100	0dB
01101	-1dB
11000	-12dB
11001 to 11111	Reserved

Table 37 Gain Register Table

ANALOGUE OUTPUTS

The WM8974 has a single MONO output and two outputs SPKOUTP and SPOUTN for driving a mono BTL speaker. These analogue output stages are supplied from SPKVDD and are capable of driving up to 1.5V rms signals (equivalent to 3V rms into a bridge tied speaker) as shown in Figure 20.

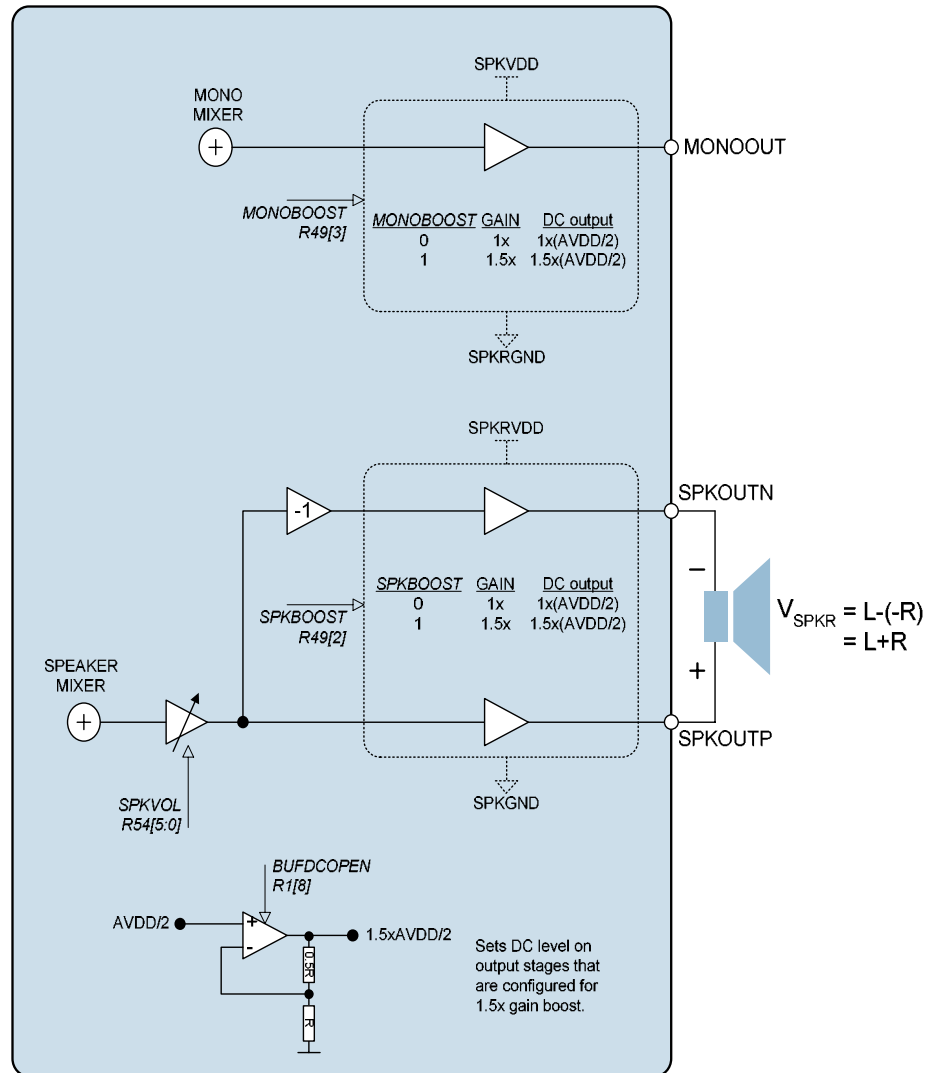

Figure 20 Speaker and Mono Analogue Outputs

The Mono and speaker outputs have output driving stages which can be controlled by the register bits MONOBOOST and SPKBOOST respectively. Each output stage has a selectable gain boost of 1.5x. When this boost is enabled the output DC level is also level shifted (from AVDD/2 to 1.5xAVDD/2) to prevent the signal from clipping. A dedicated amplifier, as shown in Figure 20, is used to perform the DC level shift operation. This buffer must be enabled using the BUFDCOPEN register bit for this operating mode. It should also be noted that if SPKVDD is not equal to or greater than 1.5xAVDD this boost mode may result in signals clipping. Table 39 summarises the effect of the SPKBOOST/MONOBOOST control bits.

REGISTER ADDRESS	BIT	LABEL	DEFAULT	DESCRIPTION
R49 Output control	2	SPKBOOST	0	Speaker output boost stage control (see Table 39 for details) 0=No boost (outputs are inverting buffers) 1 = 1.5x gain boost
	3	MONOBOOST	0	Mono output boost stage control (see Table 39 for details) 0=No boost (output is inverting buffer) 1=1.5x gain boost
R1 Power management 1	8	BUFDCOPEN	0	Dedicated buffer for DC level shifting output stages when in 1.5x gain boost configuration. 0=Buffer disabled 1=Buffer enabled (required for 1.5x gain boost)

Table 38 Output Boost Control

SPKBOOST/ MONOBOOST	OUTPUT STAGE GAIN	OUTPUT DC LEVEL	OUTPUT STAGE CONFIGURATION
0	1x	AVDD/2	Inverting
1	1.5x	1.5xAVDD/2	Non-inverting

Table 39 Output Boost Stage Details

SPKOUTP/SPKOUTN OUTPUTS

The SPKOUT pins can drive a single bridge tied 8Ω speaker or two headphone loads of 16Ω or 32Ω or a line output (see Headphone Output and Line Output sections, respectively). The signal to be output on SKPKOUT comes from the Speaker Mixer circuit and can be any combination of the DAC output, the Bypass path (output of the boost stage) and the AUX input. The SPKOUTP/N volume is controlled by the SPKVOL register bits. Note that gains over 0dB may cause clipping if the signal is large. The SPKMUTE register bit causes the speaker outputs to be muted (the output DC level is driven out). The output pins remains at the same DC level (VMIDOP), so that no click noise is produced when muting or un-muting.

The SPKOUTN pin always drives out an inverted version of the SPKOUTP signal.

REGISTER ADDRESS	BIT	LABEL	DEFAULT	DESCRIPTION
R50 Speaker mixer control	0	DAC2SPK	1	Output of DAC to speaker mixer input 0 = not selected 1 = selected
	1	BYP2SPK	0	Bypass path (output of input boost stage) to speaker mixer input 0 = not selected 1 = selected
	5	AUX2SPK	0	Output of auxiliary amplifier to speaker mixer input 0 = not selected 1 = selected
R40 Bypass path attenuation control	1	SPKATTN	0	Attenuation control for bypass path (output of input boost stage) to speaker mixer input 0 = 0dB 1 = -10dB

Table 40 Speaker Mixer Control

REGISTER ADDRESS	BIT	LABEL	DEFAULT	DESCRIPTION
R54 Speaker volume control	7	SPKZC	0	Speaker Volume control zero cross enable: 1 = Change gain on zero cross only 0 = Change gain immediately
	6	SPKMUTE	0	Speaker output mute enable 0=Speaker output enabled 1=Speaker output muted (VMIDOP)
	5:0	SPKVOL [5:0]	111001 (0dB)	Speaker Volume Adjust 111111 = +6dB 111110 = +5dB ... (1.0 dB steps) 111001=0dB ... 000000=-57dB

Table 41 SPKOUT Volume Control

ZERO CROSS TIMEOUT

A zero-cross timeout function is also provided so that if zero cross is enabled on the input or output PGAs the gain will automatically update after a timeout period if a zero cross has not occurred. This is enabled by setting SLOWCLKEN. The timeout period is dependent on the clock input to the digital and is equal to 2^{21} * input clock period.

REGISTER ADDRESS	BIT	LABEL	DEFAULT	DESCRIPTION
R7 Additional control	0	SLOWCLKEN	0	Slow clock enable. Used for both the jack insert detect debounce circuit and the zero cross timeout. 0 = slow clock disabled 1 = slow clock enabled

Table 42 Timeout Clock Enable Control

MONO MIXER AND OUTPUT

The MONOOUT pin can drive a 16Ω or 32Ω headphone or a line output or be used as a DC reference for a headphone output (see Headphone Output section). It can be selected to drive out any combination of DAC, Bypass (output of input BOOST stage) and AUX. This output is enabled by setting bit MONOEN.

REGISTER ADDRESS	BIT	LABEL	DEFAULT	DESCRIPTION
R56 Mono mixer control	0	DAC2MONO	0	Output of DAC to mono mixer input 0 = not selected 1 = selected
	1	BYP2MONO	0	Bypass path (output of input boost stage) to mono mixer input 0 = non selected 1 = selected
	2	AUX2MONO	0	Output of Auxillary amplifier to mono mixer input: 0 = not selected 1 = selected
	6	MONOMUTE	0	0=No mute 1=Output muted. During mute the mono output will output VMID which can be used as a DC reference for a headphone out.
R40 Bypass path attenuation control	2	MONOATTN	0	Attenuation control for bypass path (output of input boost stage) to mono mixer input 0 = 0dB 1 = -10dB

Table 43 Mono Mixer Control

ENABLING THE OUTPUTS

Each analogue output of the WM8974 can be separately enabled or disabled. The analogue mixer associated with each output has a separate enable. All outputs are disabled by default. To save power, unused parts of the WM8974 should remain disabled.

Outputs can be enabled at any time, but it is not recommended to do so when BUFIO is disabled (BUFIOEN=0), as this may cause pop noise (see "Power Management" and "Applications Information" sections).

REGISTER ADDRESS	BIT	LABEL	DEFAULT	DESCRIPTION
R1 Power management 1	2	BUFIOEN	0	Unused input/output tie off buffer enable
	8	BUFDCOPEN	0	Output stage 1.5xAVDD/2 driver enable
	3	BIASEN	0	Analogue amplifiers bias enable
R3 Power management 3	2	SPKMIXEN	0	Speaker Mixer enable
	3	MONOMIXEN	0	Mono mixer enable
	5	SPKPEN	0	SPKOUTP enable
	6	SPKNEN	0	SPKOUTN enable
	7	MONOEN	0	MONOOUT enable
Note: All "Enable" bits are 1 = ON, 0 = OFF				

Table 44 Output Stages Power Management Control

UNUSED ANALOGUE INPUTS/OUTPUTS

Whenever an analogue input/output is disabled, it remains connected to a voltage source (either AVDD/2 or 1.5xAVDD/2 as appropriate) through a resistor. This helps to prevent pop noise when the output is re-enabled. The resistance between the voltage buffer and the output pins can be controlled using the VROI control bit. The default impedance is low, so that any capacitors on the outputs can charge up quickly at start-up. If a high impedance is desired for disabled outputs, VROI can then be set to 1, increasing the resistance to about 30kΩ.

REGISTER ADDRESS	BIT	LABEL	DEFAULT	DESCRIPTION
R49	0	VROI	0	VREF (AVDD/2 or 1.5xAVDD/2) to analogue output resistance 0: approx 1kΩ 1: approx 30 kΩ

Table 45 Disabled Outputs to VREF Resistance

A dedicated buffer is available for tying off unused analogue I/O pins as shown in Figure 21. This buffer can be enabled using the BUFIOEN register bit.

If the SPKBOOST or MONOBOOST bits are set then the relevant outputs will be tied to the output of the DC level shift buffer at 1.5xAVDD/2 when disabled.

Table 46 summarises the tie-off options for the speaker and mono output pins.

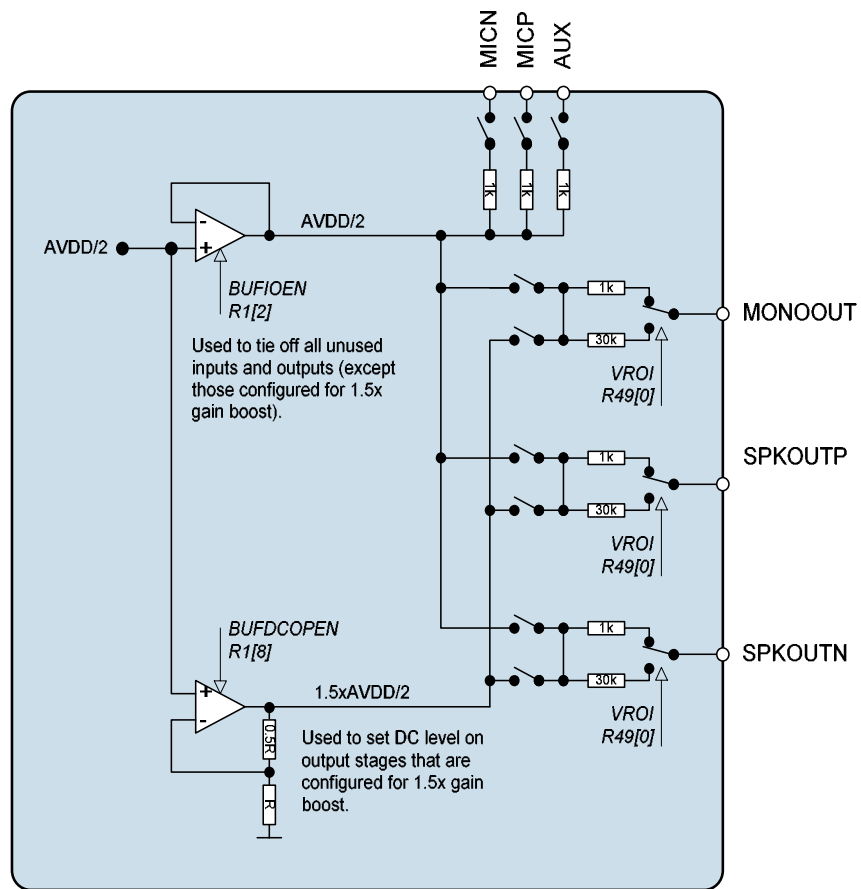

Figure 21 Unused Input/Output Pin Tie-off Buffers

MONOEN/ SPKN/PEN	MONOBOOST/ SPKBOOST	VROI	OUTPUT CONFIGURATION
0	0	0	1kΩ tieoff to AVDD/2
0	0	1	30kΩ tieoff to AVDD/2
0	1	0	1kΩ tieoff to 1.5xAVDD/2
0	1	1	30kΩ tieoff to 1.5xAVDD/2
1	0	X	Output enabled (DC level=AVDD/2)
1	1	X	Output enabled (DC level=1.5xAVDD/2)

Table 46 Unused Output Pin Tie-off Options

OUTPUT SWITCH

When the device is configured with a 2-wire interface the CSB/GPIO pin can be used as a switch control input to automatically disable the speaker outputs and enable the mono output. For example when a line is plugged into a jack socket. In this mode, enabled by setting GPIOSEL=001, pin CSB/GPIO switches between mono and speaker outputs (e.g. when pin 12 is connected to a mechanical switch in the headphone socket to detect plug-in). The GPIOPOL bit reverses the polarity of the CSB/GPIO input pin.

Note that the speaker outputs and the mono output must be enabled for this function to work (see Table 47). The CSB/GPIO pin has an internal de-bounce circuit when in this mode in order to prevent the output enables from toggling multiple times due to input glitches. This debounce circuit is clocked from a slow clock with period $2^{21} \times \text{MCLK}$, enabled using the SLOWCLKEN register bit.

GPIOPOL	CSB/GPIO	SPKNEN/ SPKPEN	MONOEN	SPEAKER ENABLED	MONO OUTPUT ENABLED
0	0	X	0	No	No
0	0	X	1	No	Yes
0	1	0	X	No	No
0	1	1	X	Yes	No
1	0	X	0	No	No
1	0	X	1	No	Yes
1	1	0	X	No	No
1	1	1	X	Yes	No

Table 47 Output Switch Operation (GPIOSEL=001)

THERMAL SHUTDOWN

The speaker outputs can drive very large currents. To protect the WM8974 from overheating a thermal shutdown circuit is included. The thermal shutdown can be configured to produce an interrupt when the device reaches approximately 125°C. See General Purpose Input/Output section.

REGISTER ADDRESS	BIT	LABEL	DEFAULT	DESCRIPTION
R49 Output control	1	TSDEN	1	Thermal Shutdown Enable 0 : thermal shutdown disabled 1 : thermal shutdown enabled

Table 48 Thermal Shutdown

SPEAKER OUTPUT

SPKOUTP/N can differentially drive a mono 8Ω Bridge Tied Load (BTL) speaker as shown below.

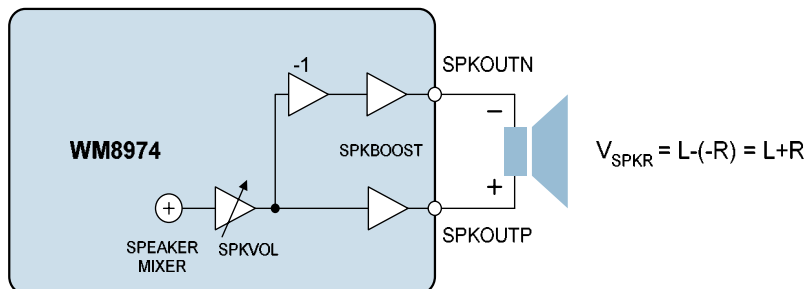
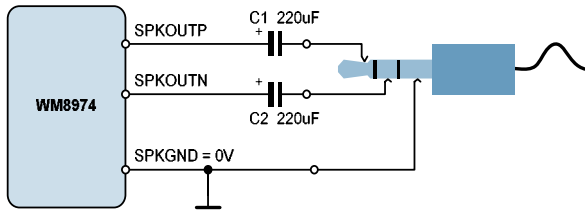

Figure 22 Speaker Output Connection

HEADPHONE OUTPUT

The speaker outputs can drive a 16Ω or 32Ω headphone load, either through DC blocking capacitors, or DC coupled without any capacitor.

Headphone Output using DC Blocking Capacitors:



DC Coupled Headphone Output:

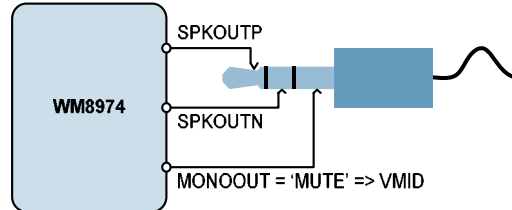

Figure 23 Recommended Headphone Output Configurations

When DC blocking capacitors are used, then their capacitance and the load resistance together determine the lower cut-off frequency, f_c . Increasing the capacitance lowers f_c , improving the bass response. Smaller capacitance values will diminish the bass response. Assuming a 16Ω load and $C_1, C_2 = 220\mu\text{F}$:

$$f_c = 1 / 2\pi R_L C_1 = 1 / (2\pi \times 16\Omega \times 220\mu\text{F}) = 45 \text{ Hz}$$

In the DC coupled configuration, the headphone “ground” is connected to the MONOOUT pin. The MONOOUT pin can be configured as a DC output driver by setting the MONOMUTE register bit. The DC voltage on MONOOUT in this configuration is equal to the DC offset on the SPROUTP and SPKOUTN pins therefore no DC blocking capacitors are required. This saves space and material cost in portable applications.

It is recommended to connect the DC coupled outputs only to headphones, and not to the line input of another device. Although the built-in short circuit protection will prevent any damage to the headphone outputs, such a connection may be noisy, and may not function properly if the other device is grounded.

MONO OUTPUT

The mono output, can be used as a line output, a headphone output or as a psuedo ground for cap-less driving of loads by SPKOUT. Recommended external components are shown below.

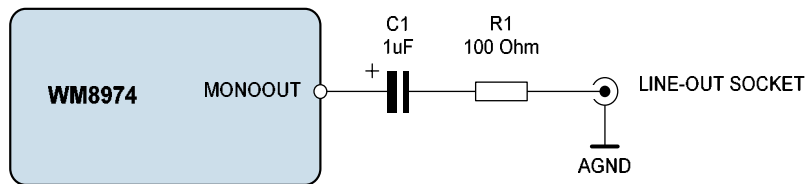

Figure 24 Recommended Circuit for Line Output

The DC blocking capacitors and the load resistance together determine the lower cut-off frequency, f_c . Assuming a 10 kΩ load and $C_1 = 1\mu\text{F}$:

$$f_c = 1 / 2\pi (R_L + R_1) C_1 = 1 / (2\pi \times 10.1\text{k}\Omega \times 1\mu\text{F}) = 16 \text{ Hz}$$

Increasing the capacitance lowers f_c , improving the bass response. Smaller values of C_1 will diminish the bass response. The function of R_1 is to protect the line outputs from damage when used improperly.

DIGITAL AUDIO INTERFACES

The audio interface has four pins:

- ADCDAT: ADC data output
- DACDAT: DAC data input
- FRAME: Data alignment clock
- BCLK: Bit clock, for synchronisation

The clock signals BCLK, and FRAME can be outputs when the WM8974 operates as a master, or inputs when it is a slave (see Master and Slave Mode Operation, below).

Four different audio data formats are supported:

- Left justified
- Right justified
- I²S
- DSP mode

All of these modes are MSB first. They are described in Audio Data Formats, below. Refer to the Electrical Characteristic section for timing information.

MASTER AND SLAVE MODE OPERATION

The WM8974 audio interface may be configured as either master or slave. As a master interface device the WM8974 generates BCLK and FRAME and thus controls sequencing of the data transfer on ADCDAT and DACDAT. To set the device to master mode register bit MS should be set high. In slave mode (MS=0), the WM8974 responds with data to clocks it receives over the digital audio interfaces.

AUDIO DATA FORMATS

In Left Justified mode, the MSB is available on the first rising edge of BCLK following an FRAME transition. The other bits up to the LSB are then transmitted in order. Depending on word length, BCLK frequency and sample rate, there may be unused BCLK cycles before each FRAME transition.

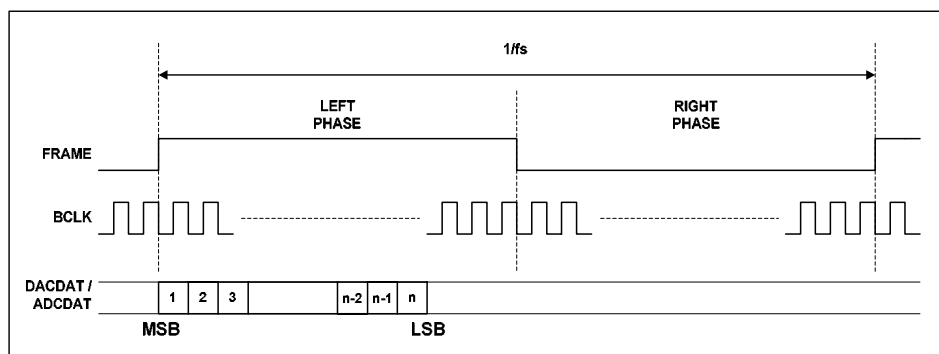

Figure 25 Left Justified Audio Interface (assuming n-bit word length)

In Right Justified mode, the LSB is available on the last rising edge of BCLK before a FRAME transition. All other bits are transmitted before (MSB first). Depending on word length, BCLK frequency and sample rate, there may be unused BCLK cycles after each FRAME transition.

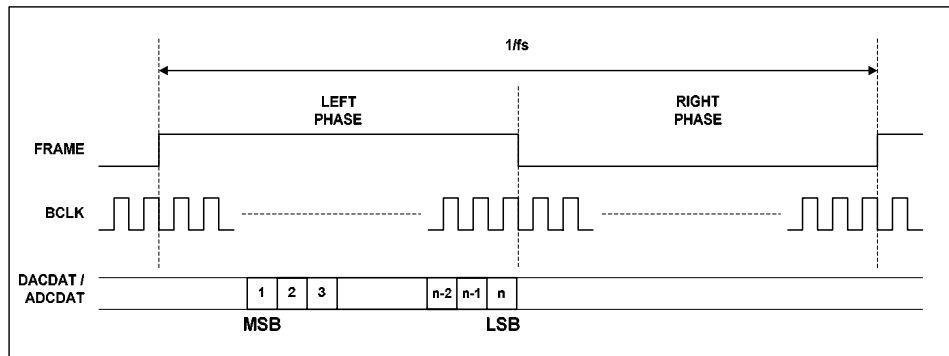

Figure 26 Right Justified Audio Interface (assuming n-bit word length)

In I²S mode, the MSB is available on the second rising edge of BCLK following a FRAME transition. The other bits up to the LSB are then transmitted in order. Depending on word length, BCLK frequency and sample rate, there may be unused BCLK cycles between the LSB of one sample and the MSB of the next.

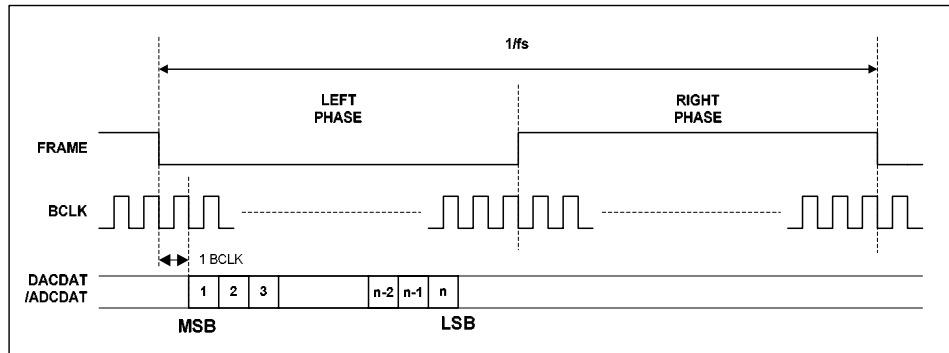

Figure 27 I²S Audio Interface (assuming n-bit word length)

In DSP/PCM mode, the left channel MSB is available on the 2nd rising edge of BCLK (selectable by LRP) following a rising edge of FRAME. Right channel data immediately follows left channel data. Depending on word length, BCLK frequency and sample rate, there may be unused BCLK cycles between the LSB of the right channel data and the next sample. FRAMEP should be set to 0 in this mode.

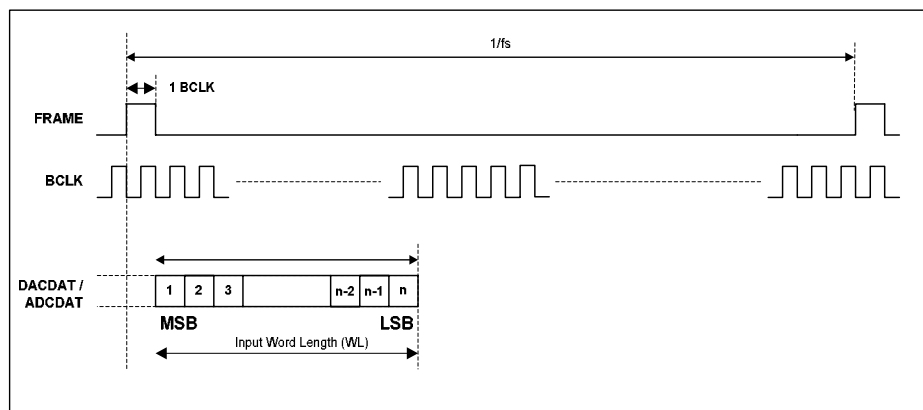

Figure 28 DSP/PCM Mode Audio Interface

REGISTER ADDRESS	BIT	LABEL	DEFAULT	DESCRIPTION
R4 Audio interface control	1	ADCLRSWAP	0	Controls whether ADC data appears in 'right' or 'left' phases of FRAME clock: 0=ADC data appear in 'left' phase of FRAME 1=ADC data appears in 'right' phase of FRAME
	2	DACLRSWAP	0	Controls whether DAC data appears in 'right' or 'left' phases of FRAME clock: 0=DAC data appear in 'left' phase of FRAME 1=DAC data appears in 'right' phase of FRAME
	4:3	FMT	10	Audio interface Data Format Select: 00=Right Justified 01=Left Justified 10= I^2S format 11= DSP/PCM mode
	6:5	WL	10	Word length 00=16 bits 01=20 bits 10=24 bits 11=32 bits (see note)
	7	FRAMEP	0	Frame clock polarity 0=normal 1=inverted DSP Mode control 1 = Reserved 0 = Configures interface so that MSB is available on 2nd BCLK rising edge after FRAME rising edge
	8	BCP	0	BCLK polarity 0=normal 1=inverted

Table 49 Audio Interface Control

Audio Interface Control

The register bits controlling audio format, word length and master / slave mode are summarised below. Each audio interface can be controlled individually.

Register bit MS selects audio interface operation in master or slave mode. In Master mode BCLK, and FRAME are outputs. The frequency of BCLK and FRAME in master mode are controlled with BCLKDIV. These are divided down versions of master clock. This may result in short BCLK pulses at the end of a frame if there is a non-integer ratio of BCLKs to FRAME clocks.

REGISTER ADDRESS	BIT	LABEL	DEFAULT	DESCRIPTION
R6 Clock generation control	0	MS	0	Sets the chip to be master over FRAME and BCLK 0=BCLK and FRAME clock are inputs 1=BCLK and FRAME clock are outputs generated by the WM8974 (MASTER)
	4:2	BCLKDIV	000	Configures the BCLK and FRAME output frequency, for use when the chip is master over BCLK. 000=divide by 1 (BCLK=MCLK) 001=divide by 2 (BCLK=MCLK/2) 010=divide by 4 011=divide by 8 100=divide by 16 101=divide by 32 110=reserved 111=reserved
	7:5	MCLKDIV	010	Sets the scaling for either the MCLK or PLL clock output (under control of CLKSEL) 000=divide by 1 001=divide by 1.5 010=divide by 2 011=divide by 3 100=divide by 4 101=divide by 6 110=divide by 8 111=divide by 12
	8	CLKSEL	1	Controls the source of the clock for all internal operation: 0=MCLK 1=PLL output

Table 50 Clock Control

LOOPBACK

Setting the LOOPBACK register bit enables digital loopback. When this bit is set the output data from the ADC audio interface is fed directly into the DAC data input.

COMPANDING

The WM8974 supports A-law and μ -law companding on both transmit (ADC) and receive (DAC) sides. Companding can be enabled on the DAC or ADC audio interfaces by writing the appropriate value to the DAC_COMP or ADC_COMP register bits respectively.

REGISTER ADDRESS	BIT	LABEL	DEFAULT	DESCRIPTION
R5 Companding control	0	LOOPBACK	0	Digital loopback function 0=No loopback 1=Loopback enabled, ADC data output is fed directly into DAC data input.
	2:1	ADC_COMP	0	ADC companding 00=off 01=reserved 10= μ -law 11=A-law
	4:3	DAC_COMP	0	DAC companding 00=off 01=reserved 10= μ -law 11=A-law

Table 51 Companding Control

Companding involves using a piecewise linear approximation of the following equations (as set out by ITU-T G.711 standard) for data compression:

μ -law (where $\mu=255$ for the U.S. and Japan):

$$F(x) = \ln(1 + \mu|x|) / \ln(1 + \mu) \quad -1 \leq x \leq 1$$

A-law (where $A=87.6$ for Europe):

$$F(x) = A|x| / (1 + \ln A) \quad \text{for } x \leq 1/A$$

$$F(x) = (1 + \ln A|x|) / (1 + \ln A) \quad \text{for } 1/A \leq x \leq 1$$

The companded data is also inverted as recommended by the G.711 standard (all 8 bits are inverted for μ -law, all even data bits are inverted for A-law). The data will be transmitted as the first 8 MSB's of data.

Companding converts 13 bits (μ -law) or 12 bits (A-law) to 8 bits using non-linear quantization. The input data range is separated into 8 levels, allowing low amplitude signals better precision than that of high amplitude signals. This is to exploit the operation of the human auditory system, where louder sounds do not require as much resolution as quieter sounds. The companded signal is an 8-bit word containing sign (1-bit), exponent (3-bits) and mantissa (4-bits).

BIT7	BIT[6:4]	BIT[3:0]
SIGN	EXPONENT	MANTISSA

Table 52 8-bit Companded Word Composition

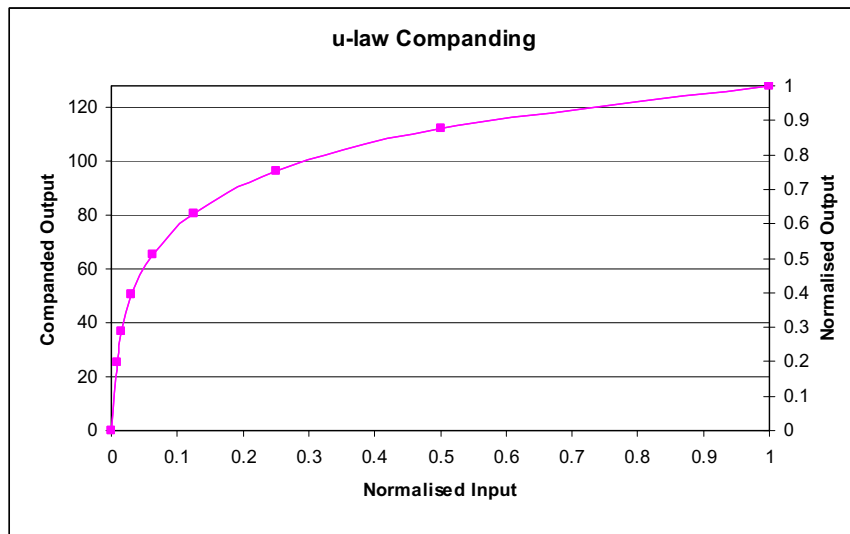

Figure 29 u-Law Comanding

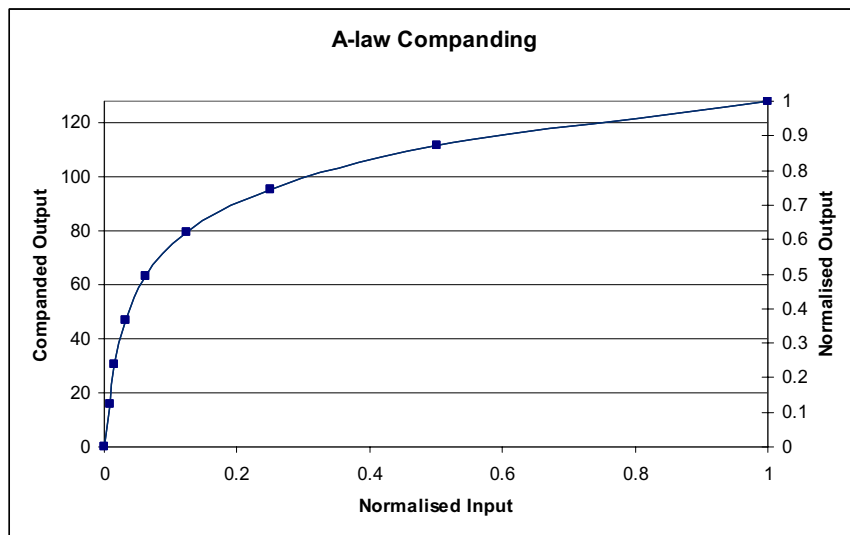

Figure 30 A-Law Comanding

AUDIO SAMPLE RATES

The WM8974 sample rates for the ADC and the DAC are set using the SR register bits. The cutoffs for the digital filters and the ALC attack/decay times stated are determined using these values and assume a 256fs master clock rate.

If a sample rate that is not explicitly supported by the SR register settings is required then the closest SR value to that sample rate should be chosen, the filter characteristics and the ALC attack, decay and hold times will scale appropriately.

REGISTER ADDRESS	BIT	LABEL	DEFAULT	DESCRIPTION
R7 Additional control	3:1	SR	000	Approximate sample rate (configures the coefficients for the internal digital filters): 000=48kHz 001=32kHz 010=24kHz 011=16kHz 100=12kHz 101=8kHz 110-111=reserved

Table 53 Sample Rate Control

MASTER CLOCK AND PHASE LOCKED LOOP (PLL)

The WM8974 has an on-chip phase-locked loop (PLL) circuit that can be used to:

Generate master clocks for the WM8974 audio functions from another external clock, e.g. in telecoms applications.

Generate and output (on pin CSB/GPIO) a clock for another part of the system that is derived from an existing audio master clock.

Figure 31 shows the PLL and internal clocking arrangement on the WM8974.

The PLL can be enabled or disabled by the PLEN register bit.

Note: In order to minimise current consumption, the PLL is disabled when the VMIDSEL[1:0] bits are set to 00b. VMIDSEL[1:0] must be set to a value other than 00b to enable the PLL.

REGISTER ADDRESS	BIT	LABEL	DEFAULT	DESCRIPTION
R1 Power management 1	5	PLEN	0	PLL enable 0=PLL off 1=PLL on

Table 54 PLEN Control Bit

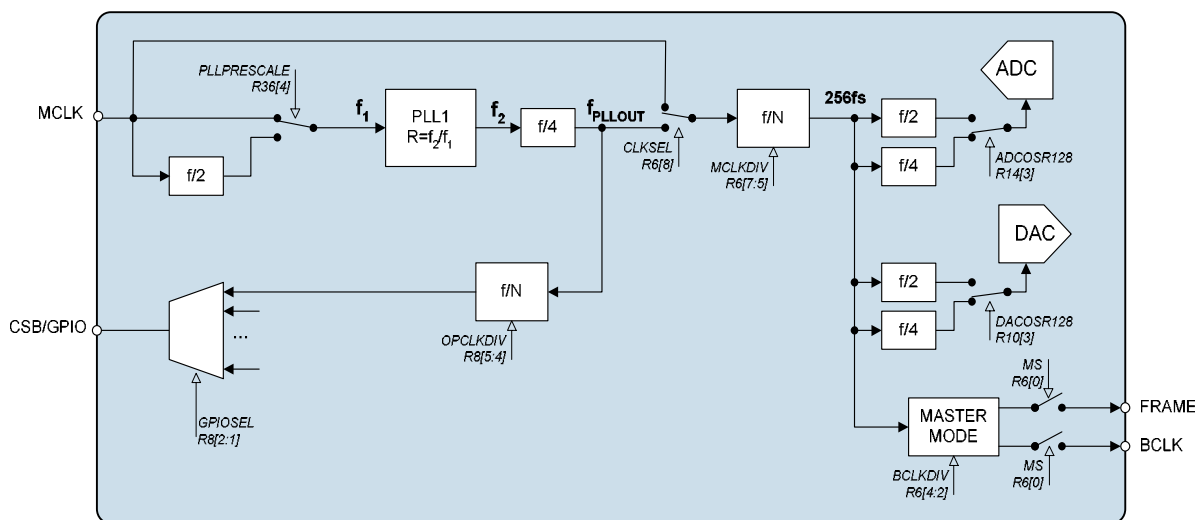

Figure 31 PLL and Clock Select Circuit

The PLL frequency ratio $R = f_2/f_1$ (see Figure 31) can be set using the register bits PLLK and PLLN:

$$PLLN = \text{int } R$$

$$PLLK = \text{int } (2^{24} (R-PLLN))$$

EXAMPLE:

MCLK=12MHz, required clock = 12.288MHz.

R should be chosen to ensure $5 < PLLN < 13$. There is a fixed divide by 4 in the PLL and a selectable divide by N after the PLL which should be set to divide by 2 to meet this requirement.

Enabling the divide by 2 sets the required $f_2 = 4 \times 2 \times 12.288\text{MHz} = 98.304\text{MHz}$.

$$R = 98.304 / 12 = 8.192$$

$$PLLN = \text{int } R = 8$$

$$k = \text{int } (2^{24} \times (8.192 - 8)) = 3221225 = 3126E9h$$

REGISTER ADDRESS	BIT	LABEL	DEFAULT	DESCRIPTION
R36 PLL N value	4	PLLPRESCALE	0	Divide MCLK by 2 before input to PLL
	3:0	PLLN	1000	Integer (N) part of PLL input/output frequency ratio. Use values greater than 5 and less than 13.
R37 PLL K value 1	5:0	PLLK [23:18]	0Ch	Fractional (K) part of PLL1 input/output frequency ratio (treat as one 24-digit binary number).
R38 PLL K Value 2	8:0	PLLK [17:9]	093h	
R39 PLL K Value 3	8:0	PLLK [8:0]	0E9h	

Table 55 PLL Frequency Ratio Control

The PLL performs best when f_2 is around 90MHz. Its stability peaks at N=8. Some example settings are shown in Table 56.

MCLK (MHz) (F1)	DESIRED OUTPUT (MHz)	F2 (MHz)	PRESCALE DIVIDE	POSTSCALE DIVIDE	R	N (Hex)	K (Hex)
12	11.29	90.3168	1	2	7.5264	7	86C220
12	12.288	98.304	1	2	8.192	8	3126E8
13	11.29	90.3168	1	2	6.947446	6	F28BD4
13	12.288	98.304	1	2	7.561846	7	8FD525
14.4	11.29	90.3168	1	2	6.272	6	45A1CA
14.4	12.288	98.304	1	2	6.826667	6	D3A06E
19.2	11.29	90.3168	2	2	9.408	9	6872AF
19.2	12.288	98.304	2	2	10.24	A	3D70A3
19.68	11.29	90.3168	2	2	9.178537	9	2DB492
19.68	12.288	98.304	2	2	9.990243	9	FD809F
19.8	11.29	90.3168	2	2	9.122909	9	1F76F7
19.8	12.288	98.304	2	2	9.929697	9	EE009E
24	11.29	90.3168	2	2	7.5264	7	86C226
24	12.288	98.304	2	2	8.192	8	3126E8
26	11.29	90.3168	2	2	6.947446	6	F28BD4
26	12.288	98.304	2	2	7.561846	7	8FD525
27	11.29	90.3168	2	2	6.690133	6	BOAC93
27	12.288	98.304	2	2	7.281778	7	482296

Table 56 PLL Frequency Examples

GENERAL PURPOSE INPUT/OUTPUT

The CSB/GPIO pin can be configured to perform a variety of useful tasks by setting the GPIOSEL register bits. The GPIO is only available in 2 wire mode.

Note that SLOWCLKEN must be enabled when using the jack detect function.

REGISTER ADDRESS	BIT	LABEL	DEFAULT	DESCRIPTION
R8 GPIO control	2:0	GPIOSEL	000	CSB/GPIO pin function select: 000=CSB input 001= Jack insert detect 010=Temp ok 011=Amute active 100=PLL clk o/p 101=PLL lock 110=Reserved 111=Reserved
	3	GPIOPOL	0	GPIO Polarity invert 0=Non inverted 1=Inverted
	5:4	OPCLKDIV	00	PLL Output clock division ratio 00=divide by 1 01=divide by 2 10=divide by 3 11=divide by 4

Table 57 CSB/GPIO Control

CONTROL INTERFACE

SELECTION OF CONTROL MODE AND 2-WIRE MODE ADDRESS

The control interface can operate as either a 3-wire or 2-wire MPU interface. The MODE pin determines the 2 or 3 wire mode as shown in Table 58.

The WM8974 is controlled by writing to registers through a serial control interface. A control word consists of 16 bits. The first 7 bits (B15 to B9) are address bits that select which control register is accessed. The remaining 9 bits (B8 to B0) are register bits, corresponding to the 9 bits in each control register.

MODE	INTERFACE FORMAT
Low	2 wire
High	3 wire

Table 58 Control Interface Mode Selection

3-WIRE SERIAL CONTROL MODE

In 3-wire mode, every rising edge of SCLK clocks in one data bit from the SDIN pin. A rising edge on CSB/GPIO latches in a complete control word consisting of the last 16 bits.

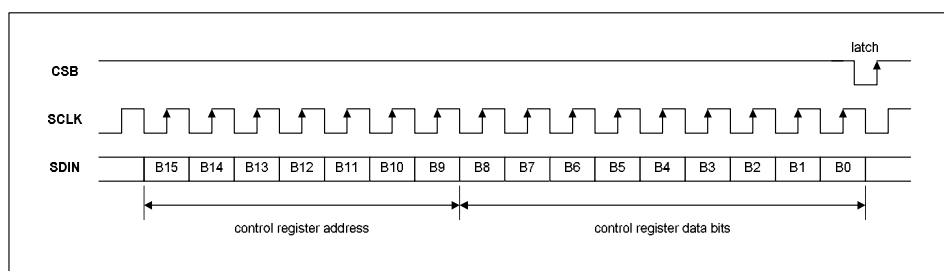

Figure 32 3-Wire Serial Control Interface

2-WIRE SERIAL CONTROL MODE

The WM8974 supports software control via a 2-wire serial bus. Many devices can be controlled by the same bus, and each device has a unique 7-bit device address (this is not the same as the 7-bit address of each register in the WM8974).

The WM8974 operates as a slave device only. The controller indicates the start of data transfer with a high to low transition on SDIN while SCLK remains high. This indicates that a device address and data will follow. All devices on the 2-wire bus respond to the start condition and shift in the next eight bits on SDIN (7-bit address + Read/Write bit, MSB first). If the device address received matches the address of the WM8974, then the WM8974 responds by pulling SDIN low on the next clock pulse (ACK). If the address is not recognised or the R/W bit is '1' when operating in write only mode, the WM8974 returns to the idle condition and wait for a new start condition and valid address.

During a write, once the WM8974 has acknowledged a correct address, the controller sends the first byte of control data (B15 to B8, i.e. the WM8974 register address plus the first bit of register data). The WM8974 then acknowledges the first data byte by pulling SDIN low for one clock pulse. The controller then sends the second byte of control data (B7 to B0, i.e. the remaining 8 bits of register data), and the WM8974 acknowledges again by pulling SDIN low.

Transfers are complete when there is a low to high transition on SDIN while SCLK is high. After a complete sequence the WM8974 returns to the idle state and waits for another start condition. If a start or stop condition is detected out of sequence at any point during data transfer (i.e. SDIN changes while SCLK is high), the device jumps to the idle condition.

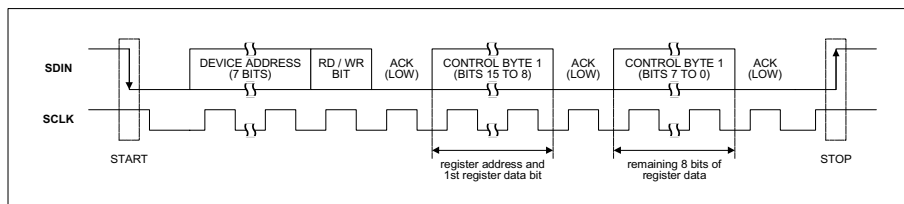

Figure 33 2-Wire Serial Control Interface

In 2-wire mode the WM8974 has a fixed device address, 00111010.

RESETTING THE CHIP

The WM8974 can be reset by performing a write of any value to the software reset register (address 0 hex). This will cause all register values to be reset to their default values. In addition to this there is a Power-On Reset (POR) circuit which ensures that the registers are set to default when the device is powered up.

POWER SUPPLIES

The WM8974 can use up to four separate power supplies:

AVDD and AGND: Analogue supply, powers all analogue functions except the speaker output and mono output drivers. AVDD can range from 2.5V to 3.6V and has the most significant impact on overall power consumption (except for power consumed in the headphone). A large AVDD slightly improves audio quality.

SPKVDD and SPKGND: Headphone and Speaker supplies, power the speaker and mono output drivers. SPKVDD can range from 2.5V to 5.5V. SPKVDD can be tied to AVDD, but it requires separate layout and decoupling capacitors to curb harmonic distortion. With a larger SPKVDD, louder headphone and speaker outputs can be achieved with lower distortion. If SPKVDD is lower than AVDD (or 1.5 x AVDD for BOOST mode), the output signal may be clipped.

DCVDD: Digital core supply, powers all digital functions except the audio and control interfaces. DCVDD can range from 1.71V to 3.6V, and has no effect on audio quality. The return path for DCVDD is DGND, which is shared with DBVDD.

DBVDD Can range from 1.71V to 3.6V. DBVDD return path is through DGND.

It is possible to use the same supply voltage for all four supplies. However, digital and analogue supplies should be routed and decoupled separately on the PCB to keep digital switching noise out of the analogue signal paths.

Note:

- DCVDD should be greater than or equal to 1.9V when using the PLL.
- DCVDD is less than or equal to DBVDD

RECOMMENDED POWER UP/DOWN SEQUENCE

In order to minimise output pop and click noise, it is recommended that the WM1400 device is powered up and down using one of the following sequences:

Power Up When NOT Using the Output 1.5x Boost Stage:

1. Turn on external power supplies. Wait for supply voltage to settle.
2. Set BIASEN = 1, BUFIOEN = 1 and also the VMIDSEL[1:0] bits in the Power Management 1 register. * Notes 1 and 2.
3. Wait for the VMID supply to settle. * Note 2.
4. Enable DAC by setting DACEN = 1.
5. Enable mixers as required.
6. Enable output stages as required.

Power Up When Using the Output 1.5x Boost Stage:

1. Turn on external power supplies. Wait for supply voltage to settle.
2. Enable 1.5x output boost. Set MONOBOOST = 1 and SPKBOOST = 1 as required.
3. Set BIASEN = 1, BUFIOEN = 1, BUFDCOPEN = 1 and also the VMIDSEL[1:0] bits in the Power Management 1 register. * Notes 1 and 2.
4. Wait for the VMID supply to settle. * Note 2.
5. Enable DAC by setting DACEN = 1.
6. Enable mixers as required.
7. Enable output stages as required.

Power Down (all cases):

1. Soft mute DAC by setting DACMU = 1.
2. Disable power management register 1 by setting R1[8:0]=0x00.
3. Disable all other output stages.
4. Turn off external power supplies.

Notes:

1. This step enables the internal device bias buffer and the VMID buffer for unassigned inputs/outputs. This will provide a startup reference voltage for all inputs and outputs. This will cause the inputs and outputs to ramp towards VMID (NOT using output 1.5x boost) or 1.5 x (AVDD/2) (using output 1.5x boost) in a way that is controlled and predictable (see note 2).
2. Choose the value of the VMIDSEL bits based on the startup time (VMIDSEL=10 for slowest startup, VMIDSEL=11 for fastest startup). Startup time is defined by the value of the VMIDSEL bits (the reference impedance) and the external decoupling capacitor on VMID.

In addition to the power on sequence, it is recommended that the zero cross functions are used when changing the volume in the PGAs to avoid any audible pops or clicks.

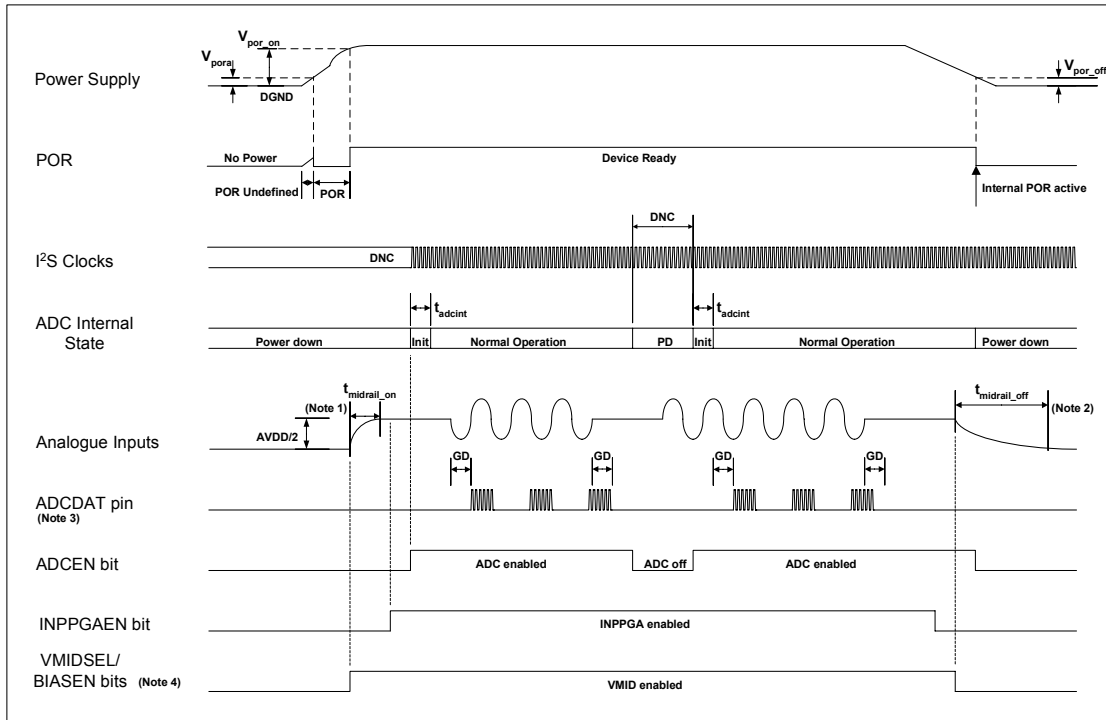

Figure 34 ADC Power Up and Down Sequence (not to scale)

SYMBOL	MIN	TYPICAL	MAX	UNIT
t _{midrail_on}		500		ms
t _{midrail_off}		>10		s
t _{adcint}		2/fs		n/fs

Table 59 Typical POR Operation (typical values, not tested)

Notes:

1. The analogue input pin charge time, $t_{\text{midrail_on}}$, is determined by the VMID pin charge time. This time is dependent upon the value of VMID decoupling capacitor and VMID pin input resistance and AVDD power supply rise time.
2. The analogue input pin discharge time, $t_{\text{midrail_off}}$, is determined by the analogue input coupling capacitor discharge time. The time, $t_{\text{midrail_off}}$, is measured using a 1µF capacitor on the analogue input but will vary dependent upon the value of input coupling capacitor.
3. While the ADC is enabled there will be LSB data bit activity on the ADCDAT pin due to system noise but no significant digital output will be present.
4. The VMIDSEL and BIASEN bits must be set to enable analogue input midrail voltage and for normal ADC operation.
5. ADCDAT data output delay from power up - with power supplies starting from 0V - is determined primarily by the VMID charge time. ADC initialisation and power management bits may be set immediately after POR is released; VMID charge time will be significantly longer and will dictate when the device is stabilised for analogue input.
6. ADCDAT data output delay at power up from device standby (power supplies already applied) is determined by ADC initialisation time, $2/f_s$.

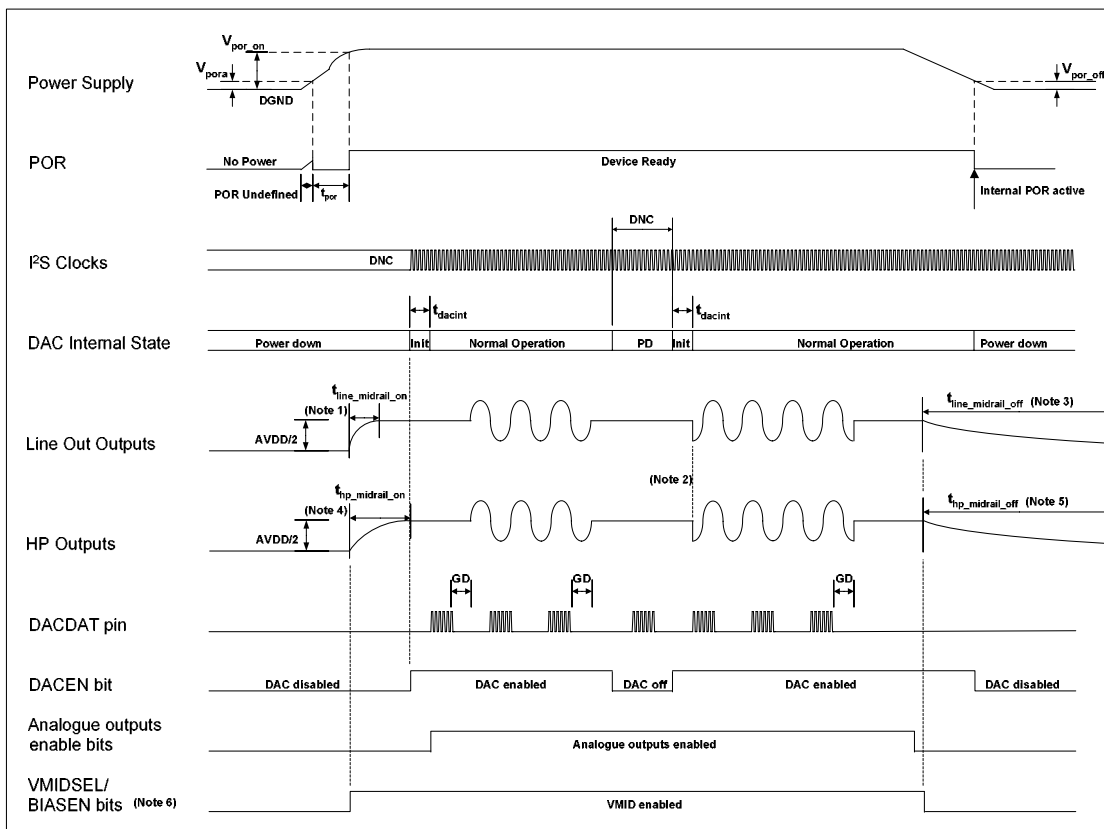

Figure 35 DAC Power Up and Down Sequence (not to scale)

SYMBOL	MIN	TYPICAL	MAX	UNIT
$t_{line_midrail_on}$		500		ms
$t_{line_midrail_off}$		1		s
$t_{hp_midrail_on}$		500		ms
$t_{hp_midrail_off}$		6		s
t_{dacint}		2/fs		n/fs

Table 60 Typical POR Operation (typical values, not tested)

Notes:

1. The lineout charge time, $t_{line_midrail_on}$, is mainly determined by the VMID pin charge time. This time is dependent upon the value of VMID decoupling capacitor and VMID pin input resistance and AVDD power supply rise time. The values above were measured using a 4.7 μ F capacitor.
2. It is not advisable to allow DACDAT data input during initialisation of the DAC. If the DAC data value is not zero at point of initialisation, then this is likely to cause a pop noise on the analogue outputs. The same is also true if the DACDAT is removed at a non-zero value, and no mute function has been applied to the signal beforehand.
3. The lineout discharge time, $t_{line_midrail_off}$, is dependent upon the value of the lineout coupling capacitor and the leakage resistance path to ground. The values above were measured using a 10 μ F output capacitor.
4. The headphone charge time, $t_{hp_midrail_on}$, is dependent upon the value of VMID decoupling capacitor and VMID pin input resistance and AVDD power supply rise time. The values above were measured using a 4.7 μ F VMID decoupling capacitor.
5. The headphone discharge time, $t_{hp_midrail_off}$, is dependent upon the value of the headphone coupling capacitor and the leakage resistance path to ground. The values above were measured using a 100 μ F capacitor.
6. The VMIDSEL and BIASEN bits must be set to enable analogue output midrail voltage and for normal DAC operation.

POWER MANAGEMENT

SAVING POWER BY REDUCING OVERSAMPLING RATE

The default mode of operation of the ADC and DAC digital filters is in 64x oversampling mode. Under the control of ADCOSR and DACOSR the oversampling rate may be doubled. 64x oversampling results in a slight decrease in noise performance compared to 128x but lowers the power consumption of the device.

REGISTER ADDRESS	BIT	LABEL	DEFAULT	DESCRIPTION
R10 DAC control	3	DACOSR128	0	DAC oversample rate select 0 = 64x (lowest power) 1 = 128x (best SNR)
R14 ADC control	3	ADCOSR128	0	ADC oversample rate select 0 = 64x (lowest power) 1 = 128x (best SNR)

Table 61 ADC and DAC Oversampling Rate Selection

VMID

The analogue circuitry will not work when VMID is disabled (VMIDSEL[1:0] = 00b). The impedance of the VMID resistor string, together with the decoupling capacitor on the VMID pin will determine the startup time of the VMID circuit.

REGISTER ADDRESS	BIT	LABEL	DEFAULT	DESCRIPTION
R1 Power management 1	1:0	VMIDSEL	00	Reference string impedance to VMID pin (determines startup time): 00=off (open circuit) 01=75k Ω 10=300k Ω 11=2.5k Ω (for fastest startup)

Table 62 VMID Impedance Control

BIASEN

REGISTER ADDRESS	BIT	LABEL	DEFAULT	DESCRIPTION
R1 Power management 1	3	BIASEN	0	Analogue amplifier bias control 0=Disabled 1=Enabled

Table 63 BIAS EN Control

ESTIMATED SUPPLY CURRENTS

When either the DAC or ADC are enabled it is estimated that approximately 4mA will be drawn from DCVDD when DCVDD=1.8V and fs=48kHz (This will be lower at lower sample rates). When the PLL is enabled an additional 700 microamps will be drawn from DCVDD.

Table 59 shows the estimated 3.3V AVDD current drawn by various circuits, by register bit.

REGISTER BIT	AVDD CURRENT (MILLIAMPS)
BUFDCOPEN	0.1
MONOEN	0.2
PLLEN	1.4 (with clocks applied)
MICBEN	0.5
BIASEN	0.3
BUFIOEN	0.1
VMIDSEL	10K=>0.3, less than 0.1 for 100k/500k
BOOSTEN	0.2
INPPGAEN	0.2
ADCEN	x64 (ADCOSR=0)=>2.6, x128 (ADCOSR=1)=>4.9
MONOEN	0.2
SPKPEN	1mA from SPKVDD + 0.2mA from AVDD in 5V mode
SPKNEN	1mA from SPKVDD + 0.2mA from AVDD in 5V mode
MONOMIXEN	0.2
SPKMIXEN	0.2
DACEN	x64 (DACOSR=0)=>1.8, x128(DACOSR=1)=>1.9

Table 64 AVDD Supply Current

REGISTER MAP

ADDR B[15:9]		REGISTER NAME	B8	B7	B6	B5	B4	B3	B2	B1	B0	DEF'T VAL	
DEC	HEX											(HEX)	
0	00	Software Reset	Software reset										
1	01	Power manage't 1	BUFDCOP EN	0	AUXEN	PLLEN	MICBEN	BIASEN	BUFIOEN	VMIDSEL		000	
2	02	Power manage't 2	0	0	0	0	BOOSTEN	0	INPPGAEN	0	ADCEN	000	
3	03	Power manage't 3	0	MONOEN	SPKNEN	SPKPEN	0	MONO MIXEN	SPK MIXEN	0	DACEN	000	
4	04	Audio Interface	BCP	FRAMEP	WVL		FMT		DACLRSW AP	ADCLRSW AP	0	050	
5	05	Companing ctrl	0	0	0	0	DAC_COMP		ADC_COMP		LOOPBACK	000	
6	06	Clock Gen ctrl	CLKSEL	MCLKDIV			BCLKDIV			0	MS	140	
7	07	Additional ctrl	0	0	0	0	0	SR			SLOWCLKE N	000	
8	08	GPIO Stuff	0	0	0	OPCLKDIV		GPIOPOL	GPIOSEL			000	
10	0A	DAC Control	0	0	DACMU	DEEMPH		DACOSR 128	AMUTE	0	DACPOL	000	
11	0B	DAC digital Vol	0	DACVOL								OFF	
14	0E	ADC Control	HPFEN	HPFAPP	HPFCUT			ADCOSR 128	0	0	ADCPOL	100	
15	0F	ADC Digital Vol	0	ADCVOL								OFF	
18	12	EQ1 – low shelf	EQMODE	0	EQ1C		EQ1G				12C		
19	13	EQ2 – peak 1	EQ2BW	0	EQ2C		EQ2G				02C		
20	14	EQ3 – peak 2	EQ3BW	0	EQ3C		EQ3G				02C		
21	15	EQ4 – peak 3	EQ4BW	0	EQ4C		EQ4G				02C		
22	16	EQ5 – high shelf	0	0	EQ5C		EQ5G				02C		
24	18	DAC Limiter 1	LIMEN	LIMDCY				LIMATK				032	
25	19	DAC Limiter 2	0	0	LIMLVL			LIMBOOST				000	
27	1B	Notch Filter 1	NFU	NFEN	NFA0[13:7]							000	
28	1C	Notch Filter 2	NFU	0	NFA0[6:0]							000	
29	1D	Notch Filter 3	NFU	0	NFA1[13:7]							000	
30	1E	Notch Filter 4	NFU	0	NFA1[6:0]							000	
32	20	ALC control 1	ALCSEL	0	0	ALCMAX			ALCMIN			038	
33	21	ALC control 2	ALCZC	ALCHLD				ALCLVL				00B	
34	22	ALC control 3	ALCMODE	ALCDCY				ALCATK				032	
35	23	Noise Gate	0	0	0	0	0	NGEN	NGTH			000	
36	24	PLL N	0	0	0	0	PLLPRE SCALE	PLLN[3:0]				008	
37	25	PLL K 1	0	0	0	PLLK[23:18]						00C	
38	26	PLL K 2	PLLK[17:9]									093	
39	27	PLL K 3	PLLK[8:0]									0E9	
40	28	Attenuation ctrl	0	0	0	0	0	0	MONOATT N	SPKATTN	0	000	
44	2C	Input ctrl	MBVSEL	0	0	0	0	AUXMODE	AUX2 INPPGA	MICN2 INPPGA	MICP2 INPPGA	003	
45	2D	INP PGA gain ctrl	0	INPPGAZC	INPPGA MUTE	INPPGAVOL						010	
47	2F	ADC Boost ctrl	PGABOOST	0	MICP2BOOSTVOL			0	AUX2BOOSTVOL				000
49	31	Output ctrl	0	0	0	0	0	MONO BOOST	SPK BOOST	TSDEN	VROI	002	
50	32	SPK mixer ctrl	0	0	0	AUX2SPK	0	0	0	BYP2SPK	DAC2SPK	000	

WM8974

Pre-Production

ADDR B[15:9]		REGISTER NAME	B8	B7	B6	B5	B4	B3	B2	B1	B0	DEF'T VAL
DEC	HEX											(HEX)
54	36	SPK volume ctrl	0	SPKZC	SPKMUTE	SPKVOL					039	
56	38	MONO mixer ctrl	0	0	MONO MUTE	0	0	0	AUX2 MONO	BYP2 MONO	DAC2 MONO	000

REGISTER BITS BY ADDRESS

Notes:

1. Default values of N/A indicate non-latched data bits (e.g. software reset or volume update bits).
2. Register bits marked as "Reserved" should not be changed from the default.

REGISTER ADDRESS	BIT	LABEL	DEFAULT	DESCRIPTION	REFER TO
0 (00h)	[8:0]	RESET	N/A	Software reset	Resetting the Chip
1 (01h)	8	BUFDCOPEN	0	Dedicated buffer for DC level shifting output stages when in 1.5x gain boost configuration. 0=Buffer disabled 1=Buffer enabled (required for 1.5x gain boost)	Analogue Outputs
	7		0	Reserved	
	6	AUXEN	0	Auxiliary input buffer enable 0 = OFF 1 = ON	Auxiliary Inputs
	5	PLLEN	0	PLL enable 0=PLL off 1=PLL on	Master Clock and Phase Locked Loop (PLL)
	4	MICBEN	0	Microphone Bias Enable 0 = OFF (high impedance output) 1 = ON	Microphone Biasing Circuit
	3	BIASEN	0	Analogue amplifier bias control 0=Disabled 1=Enabled	Power Management
	2	BUFIOEN	0	Unused input/output tie off buffer enable 0=Disabled 1=Enabled	Enabling the Outputs
	1:0	VMIDSEL	00	Reference string impedance to VMID pin: 00=off (open circuit) 01=75kΩ 10=300kΩ 11=2.5kΩ	Power Management
2 (02h)	8:5		0000	Reserved	
	4	BOOSTEN	0	Input BOOST enable 0 = Boost stage OFF 1 = Boost stage ON	Input Boost
	3		0	Reserved	
	2	INPPGAEN	0	Input microphone PGA enable 0 = disabled 1 = enabled	Input Signal Path
	1		0	Reserved	
	0	ADCEN	0	ADC Enable Control 0 = ADC disabled 1 = ADC enabled	Analogue to Digital Converter (ADC)
3 (03h)	8		0	Reserved	
	7	MONOEN	0	MONOOUT enable 0 = disabled 1 = enabled	Analogue Outputs
	6	SPKNEN	0	SPKOUTN enable 0 = disabled 1 = enabled	Analogue Outputs
	5	SPKPEN	0	SPKOUTP enable 0 = disabled 1 = enabled	Analogue Outputs

REGISTER ADDRESS	BIT	LABEL	DEFAULT	DESCRIPTION	REFER TO
	4		0	Reserved	
	3	MONOMIXEN	0	Mono Mixer Enable 0 = disabled 1 = enabled	Analogue Outputs
	2	SPKMIXEN	0	Speaker Mixer Enable 0 = disabled 1 = enabled	Analogue Outputs
	1		0	Reserved	
	0	DACEN	0	DAC enable 0 = DAC disabled 1 = DAC enabled	Analogue Outputs
4 (04h)	8	BCP	0	BCLK polarity 0=normal 1=inverted	Digital Audio Interfaces
	7	FRAMEP	0	Frame clock polarity 0=normal 1=inverted	Digital Audio Interfaces
				DSP Mode control 1 = Reserved 0 = Configures the interface so that MSB is available on 2nd BCLK rising edge after FRAME rising edge	
	6:5	WL	10	Word length 00=16 bits 01=20 bits 10=24 bits 11=32 bits	Digital Audio Interfaces
	4:3	FMT	10	Audio interface Data Format Select: 00=Right Justified 01=Left Justified 10=I ² S format 11= DSP/PCM mode	Digital Audio Interfaces
	2	DACLRSWAP	0	Controls whether DAC data appears in 'right' or 'left' phases of FRAME clock: 0=DAC data appear in 'left' phase of FRAME 1=DAC data appears in 'right' phase of FRAME	Digital Audio Interfaces
	1	ADCLRSWAP	0	Controls whether ADC data appears in 'right' or 'left' phases of FRAME clock: 0=ADC data appear in 'left' phase of FRAME 1=ADC data appears in 'right' phase of FRAME	Digital Audio Interfaces
	0		0	Reserved	
5 (05h)	8:5		0000	Reserved	
	4:3	DAC_COMP	00	DAC companding 00=off 01=reserved 10= μ -law 11=A-law	Digital Audio Interfaces
	2:1	ADC_COMP	00	ADC companding 00=off 01=reserved 10= μ -law 11=A-law	Digital Audio Interfaces
	0	LOOPBACK	0	Digital loopback function 0=No loopback 1=Loopback enabled, ADC data output is fed directly into DAC data input.	Digital Audio Interfaces

REGISTER ADDRESS	BIT	LABEL	DEFAULT	DESCRIPTION	REFER TO
6 (06h)	8	CLKSEL	1	Controls the source of the clock for all internal operation: 0=MCLK 1=PLL output	Digital Audio Interfaces
	7:5	MCLKDIV	010	Sets the scaling for either the MCLK or PLL clock output (under control of CLKSEL) 000=divide by 1 001=divide by 1.5 010=divide by 2 011=divide by 3 100=divide by 4 101=divide by 6 110=divide by 8 111=divide by 12	Digital Audio Interfaces
	4:2	BCLKDIV	000	Configures the BCLK and FRAME output frequency, for use when the chip is master over BCLK. 000=divide by 1 (BCLK=MCLK) 001=divide by 2 (BCLK=MCLK/2) 010=divide by 4 011=divide by 8 100=divide by 16 101=divide by 32 110=reserved 111=reserved	Digital Audio Interfaces
	1		0	Reserved	
	0	MS	0	Sets the chip to be master over FRAME and BCLK 0=BCLK and FRAME clock are inputs 1=BCLK and FRAME clock are outputs generated by the WM8974 (MASTER)	Digital Audio Interfaces
7 (07h)	8:4		00000	Reserved	
	3:1	SR	000	Approximate sample rate (configures the coefficients for the internal digital filters): 000=48kHz 001=32kHz 010=24kHz 011=16kHz 100=12kHz 101=8kHz 110-111=reserved	Audio Sample Rates
	0		0	Reserved	
8 (08h)	8:6		000	Reserved	
	5:4	OPCLKDIV	00	PLL Output clock division ratio 00=divide by 1 01=divide by 2 10=divide by 3 11=divide by 4	General Purpose Input Output
	3	GPIOPOL	0	GPIO Polarity invert 0=Non inverted 1=Inverted	General Purpose Input Output

REGISTER ADDRESS	BIT	LABEL	DEFAULT	DESCRIPTION	REFER TO
	2:0	GPIOSEL	000	CSB/GPIO pin function select: 000=CSB input 001= Jack insert detect 010=Temp ok 011=Amute active 100=PLL clk o/p 101=PLL lock 110=Reserved 111=Reserved	General Purpose Input Output
9 (09h)	8:0			Reserved	
10 (0Ah)	8:7		00	Reserved	
	6	DACMU	0	DAC soft mute enable 0 = DACMU disabled 1 = DACMU enabled	Output Signal Path
	5:4	DEEMPH	00	De-Emphasis Control 00 = No de-emphasis 01 = 32kHz sample rate 10 = 44.1kHz sample rate 11 = 48kHz sample rate	Output Signal Path
	3	DACOSR128	0	DAC oversample rate select 0 = 64x (lowest power) 1 = 128x (best SNR)	Power Management
	2	AMUTE	0	DAC auto mute enable 0 = auto mute disabled 1 = auto mute enabled	Output Signal Path
	1		0	Reserved	
	0	DACPOL	0	DAC Polarity Invert 0 = No inversion 1 = DAC output inverted	Output Signal Path
11 (0Bh)	8		0	Reserved	
	7:0	DACVOL	11111111	DAC Digital Volume Control 0000 0000 = Digital Mute 0000 0001 = -127dB 0000 0010 = -126.5dB ... 0.5dB steps up to 1111 1111 = 0dB	Output Signal Path
12 (0Ch)	8:0			Reserved	
13 (0Dh)	8:0			Reserved	
14 (0Eh)	8	HPFEN	1	High Pass Filter Enable 0=disabled 1=enabled	Analogue to Digital Converter (ADC)
	7	HPFAPP	0	Select audio mode or application mode 0=Audio mode (1 st order, fc = ~3.7Hz) 1=Application mode (2 nd order, fc = HPFCUT)	Analogue to Digital Converter (ADC)
	6:4	HPFCUT	000	Application mode cut-off frequency See Table 11 for details.	Analogue to Digital Converter (ADC)
	3	ADCOSR128	0	ADC oversample rate select 0 = 64x (lowest power) 1 = 128x (best SNR)	Power Management
	2:1		00	Reserved	
	0	ADCPOL	0	ADC Polarity 0=normal 1=inverted	Analogue to Digital Converter (ADC)
15 (0Fh)	8		0	Reserved	

REGISTER ADDRESS	BIT	LABEL	DEFAULT	DESCRIPTION	REFER TO
	7:0	ADCVOL	11111111	ADC Digital Volume Control 0000 0000 = Digital Mute 0000 0001 = -127dB 0000 0010 = -126.5dB ... 0.5dB steps up to 1111 1111 = 0dB	Analogue to Digital Converter (ADC)
16 (10h)	8:0			Reserved	
17 (11h)	8:0			Reserved	
18 (12h)	8	EQMODE	1	0 = Equaliser applied to ADC path 1 = Equaliser applied to DAC path	Output Signal Path
	7		0	Reserved	
	6:5	EQ1C	01	EQ Band 1 Cut-off Frequency: 00=80Hz 01=105Hz 10=135Hz 11=175Hz	Output Signal Path
	4:0	EQ1G	01100	EQ Band 1 Gain Control. See Table 37 for details.	Output Signal Path
19 (13h)	8	EQ2BW	0	Band 2 Bandwidth Control 0=narrow bandwidth 1=wide bandwidth	Output Signal Path
	7		0	Reserved	
	6:5	EQ2C	01	Band 2 Centre Frequency: 00=230Hz 01=300Hz 10=385Hz 11=500Hz	Output Signal Path
	4:0	EQ2G	01100	Band 2 Gain Control. See Table 37 for details.	Output Signal Path
20 (14h)	8	EQ3BW	0	Band 3 Bandwidth Control 0=narrow bandwidth 1=wide bandwidth	Output Signal Path
	7		0	Reserved	
	6:5	EQ3C	01	Band 3 Centre Frequency: 00=650Hz 01=850Hz 10=1.1kHz 11=1.4kHz	Output Signal Path
	4:0	EQ3G	01100	Band 3 Gain Control. See Table 37 for details.	Output Signal Path
21 (15h)	8	EQ4BW	0	Band 4 Bandwidth Control 0=narrow bandwidth 1=wide bandwidth	Output Signal Path
	7		0	Reserved	
	6:5	EQ4C	01	Band 4 Centre Frequency: 00=1.8kHz 01=2.4kHz 10=3.2kHz 11=4.1kHz	Output Signal Path
	4:0	EQ4G	01100	Band 4 Gain Control. See Table 37 for details.	Output Signal Path
22 (16h)	8:7		00	Reserved	
	6:5	EQ5C	01	Band 5 Cut-off Frequency: 00=5.3kHz 01=6.9kHz 10=9kHz 11=11.7kHz	Output Signal Path
	4:0	EQ5G	01100	Band 5 Gain Control. See Table 37 for details.	Output Signal Path

REGISTER ADDRESS	BIT	LABEL	DEFAULT	DESCRIPTION	REFER TO
24 (18h)	8	LIMEN	0	Enable the DAC digital limiter: 0=disabled 1=enabled	Output Signal Path
	7:4	LIMDCY	0011	DAC Limiter Decay time (per 6dB gain change) for 44.1kHz sampling. Note that these will scale with sample rate: 0000=750us 0001=1.5ms 0010=3ms 0011=6ms 0100=12ms 0101=24ms 0110=48ms 0111=96ms 1000=192ms 1001=384ms 1010=768ms 1011 to 1111=1.536s	Output Signal Path
	3:0	LIMATK	0010	DAC Limiter Attack time (per 6dB gain change) for 44.1kHz sampling. Note that these will scale with sample rate. 0000=94us 0001=188s 0010=375us 0011=750us 0100=1.5ms 0101=3ms 0110=6ms 0111=12ms 1000=24ms 1001=48ms 1010=96ms 1011 to 1111=192ms	Output Signal Path
25 (19h)	8:7		00	Reserved	
	6:4	LIMLVL	000	DAC Limiter Programmable signal threshold level (determines level at which the limiter starts to operate) 000=-1dB 001=-2dB 010=-3dB 011=-4dB 100=-5dB 101 to 111=-6dB	Output Signal Path
	3:0	LIMBOOST	0000	DAC Limiter volume boost (can be used as a stand alone volume boost when LIMEN=0): 0000=0dB 0001=+1dB 0010=+2dB ... (1dB steps) 1011=+11dB 1100=+12dB 1101 to 1111=reserved	Output Signal Path
27 (1Bh)	8	NFU	0	Notch filter update. The notch filter values used internally only update when one of the NFU bits is set high.	Analogue to Digital Converter (ADC)

REGISTER ADDRESS	BIT	LABEL	DEFAULT	DESCRIPTION	REFER TO
	7	NFEN	0	Notch filter enable: 0=Disabled 1=Enabled	Analogue to Digital Converter (ADC)
	6:0	NFA0[13:7]	0000000	Notch Filter a0 coefficient, bits [13:7]	Analogue to Digital Converter (ADC)
28 (1Ch)	8	NFU	0	Notch filter update. The notch filter values used internally only update when one of the NFU bits is set high.	Analogue to Digital Converter (ADC)
	7		0	Reserved	
	6:0	NFA0[6:0]	0000000	Notch Filter a0 coefficient, bits [6:0]	Analogue to Digital Converter (ADC)
29 (1Dh)	8	NFU	0	Notch filter update. The notch filter values used internally only update when one of the NFU bits is set high.	Analogue to Digital Converter (ADC)
	7		0	Reserved	
	6:0	NFA1[13:7]	0000000	Notch Filter a1 coefficient, bits [13:7]	Analogue to Digital Converter (ADC)
30 (1Eh)	8	NFU	0	Notch filter update. The notch filter values used internally only update when one of the NFU bits is set high.	Analogue to Digital Converter (ADC)
	7		0	Reserved	
	6:0	NFA1[6:0]	0000000	Notch Filter a1 coefficient, bits [6:0]	Analogue to Digital Converter (ADC)
32 (20h)	8	ALCSEL	0	ALC function select: 0=ALC off (PGA gain set by INPPGAVOL register bits) 1=ALC on (ALC controls PGA gain)	Input Limiter / Automatic Level Control (ALC)
	7:6			Reserved	
	5:3	ALCMAX	111	Set Maximum Gain of PGA when using ALC: 111=+35.25dB 110=+29.25dB 101=+23.25dB 100=+17.25dB 011=+11.25dB 010=+5.25dB 001=-0.75dB 000=-6.75dB	Input Limiter / Automatic Level Control (ALC)
	2:0	ALCMIN	000	Set minimum gain of PGA when using ALC: 000=-12dB 001=-6dB 010=0dB 011=+6dB 100=+12dB 101=+18dB 110=+24dB 111=+30dB	Input Limiter / Automatic Level Control (ALC)
33 (21h)	8	ALCZC	0	ALC zero cross detection. 0 = disabled 1 = enabled	Input Limiter / Automatic Level Control (ALC)
	7:4	ALCHLD	000	ALC hold time before gain is increased. 0000 = 0ms 0001 = 2.67ms 0010 = 5.33ms ... (time doubles with every step) 1111 = 43.691s	Input Limiter / Automatic Level Control (ALC)

REGISTER ADDRESS	BIT	LABEL	DEFAULT	DESCRIPTION	REFER TO			
	3:0	ALCLVL	1011	ALC target – sets signal level at ADC input 0000 = -28.5dB FS 0001 = -27.0dB FS ... (1.5dB steps) 1110 = -7.5dB FS 1111 = -6dB FS	Input Limiter / Automatic Level Control (ALC)			
34 (22h)	8	ALCMODE	0	Determines the ALC mode of operation: 0=ALC mode 1=Limiter mode.	Input Limiter / Automatic Level Control (ALC)			
		7:4	ALCDCY	0011	Decay (gain ramp-up) time (ALCMODE =0)	Input Limiter / Automatic Level Control (ALC)		
					Per step		Per 6dB	90% of range
	0000				410us		3.3ms	24ms
	0001				820us		6.6ms	48ms
	0010				1.64ms		13.1ms	192ms
	... (time doubles with every step)							
	1010 or higher				420ms		3.36s	24.576s
					Per step		Per 6dB	90% of range
	0000				90.8us		726.4us	5.26ms
	0001				181.6us		1.453ms	10.53ms
	0010				363.2us		2.905ms	21.06ms
	... (time doubles with every step)							
	1010	93ms	744ms	5.39s				
	3:0	ALCATK	0010	ALC attack (gain ramp-down) time (ALCMODE = 0)	Input Limiter / Automatic Level Control (ALC)			
						Per step	Per 6dB	90% of range
				0000		104us	832us	6ms
				0001		208us	1.664ms	12ms
				0010		416us	3.328ms	24.1ms
				... (time doubles with every step)				
				1010 or higher		106ms	852ms	6.18s
						Per step	Per 6dB	90% of range
				0000		22.7us	182.4us	1.31ms
				0001		45.4us	363.2us	2.62ms
				0010		90.8us	726.4us	5.26ms
				... (time doubles with every step)				
				1010		23.2ms	186ms	1.348s
				35 (23h)		8:4		00000
3	NGEN	0	ALC Noise gate function enable 1 = enable 0 = disable		Input Limiter / Automatic Level Control (ALC)			
2:0	NGTH	000	ALC Noise gate threshold: 000=-39dB 001=-45dB 010=-51dB ... (6dB steps) 111=-81dB		Input Limiter / Automatic Level Control (ALC)			
36 (24h)	8:5		0000	Reserved				

REGISTER ADDRESS	BIT	LABEL	DEFAULT	DESCRIPTION	REFER TO
	4	PLLPRESCALE	0	Divide MCLK by 2 before input to PLL 0 = disabled 1 = enabled	Master Clock and Phase Locked Loop (PLL)
	3:0	PLLN[3:0]	1000	Integer (N) part of PLL input/output frequency ratio. Use values greater than 5 and less than 13.	Master Clock and Phase Locked Loop (PLL)
37 (25h)	8:6		000	Reserved	
	5:0	PLLK[23:18]	001100	Fractional (K) part of PLL1 input/output frequency ratio (treat as one 24-digit binary number).	Master Clock and Phase Locked Loop (PLL)
38 (26h)	8:0	PLLK[17:9]	010010011	Fractional (K) part of PLL1 input/output frequency ratio (treat as one 24-digit binary number).	Master Clock and Phase Locked Loop (PLL)
39 (27h)	8:0	PLLK[8:0]	011101001	Fractional (K) part of PLL1 input/output frequency ratio (treat as one 24-digit binary number).	Master Clock and Phase Locked Loop (PLL)
40 (28h)	8:3		000000	Reserved	
	2	MONOATTN	0	Attenuation control for bypass path (output of input boost stage) to mono mixer input 0 = 0dB 1 = -10dB	Analogue Outputs
	1	SPKATTN	0	Attenuation control for bypass path (output of input boost stage) to speaker mixer input 0 = 0dB 1 = -10dB	Analogue Outputs
	0		0	Reserved	
44 (2Ch)	8	MBVSEL	0	Microphone Bias Voltage Control 0 = 0.9 * AVDD 1 = 0.65 * AVDD	Input Signal Path
	7:4		0000	Reserved	
	3	AUXMODE	0	Auxiliary Input Mode 0 = inverting buffer 1 = mixer (on-chip input resistor bypassed)	Input Signal Path
	2	AUX2INPPGA	0	Select AUX amplifier output as input PGA signal source. 0=AUX not connected to input PGA 1=AUX connected to input PGA amplifier negative terminal.	Input Signal Path
	1	MICN2INPPGA	1	Connect MICN to input PGA negative terminal. 0=MICN not connected to input PGA 1=MICN connected to input PGA amplifier negative terminal.	Input Signal Path
	0	MICP2INPPGA	1	Connect input PGA amplifier positive terminal to MICP or VMID. 0 = input PGA amplifier positive terminal connected to VMID 1 = input PGA amplifier positive terminal connected to MICP through variable resistor string	Input Signal Path
45 (2Dh)	8		0	Reserved	
	7	INPPGAZC	0	Input PGA zero cross enable: 0=Update gain when gain register changes 1=Update gain on 1 st zero cross after gain register write.	Input Signal Path
	6	INPPGAMUTE	0	Mute control for input PGA: 0=Input PGA not muted, normal operation 1=Input PGA muted (and disconnected from the following input BOOST stage).	Input Signal Path

REGISTER ADDRESS	BIT	LABEL	DEFAULT	DESCRIPTION	REFER TO
	5:0	INPPGAVOL	010000	Input PGA volume 000000 = -12dB 000001 = -11.25db . 010000 = 0dB . 111111 = 35.25dB	Input Signal Path
47 (2Fh)	8	PGABOOST	0	Input Boost 0 = PGA output has +0dB gain through input BOOST stage. 1 = PGA output has +20dB gain through input BOOST stage.	Input Signal Path
	7		0	Reserved	
	6:4	MICP2BOOSTVOL	000	Controls the MICP pin to the input boost stage (NB, when using this path set MICP2INPPGA=0): 000=Path disabled (disconnected) 001=-12dB gain through boost stage 010=-9dB gain through boost stage ... 111=+6dB gain through boost stage	Input Signal Path
	3		0	Reserved	
	2:0	AUX2BOOSTVOL	000	Controls the auxilliary amplifier to the input boost stage: 000=Path disabled (disconnected) 001=-12dB gain through boost stage 010=-9dB gain through boost stage ... 111=+6dB gain through boost stage	Input Signal Path
49 (31h)	8:4		00000	Reserved	
	3	MONOBOOST	0	Mono output boost stage control (see Table 39 for details) 0=No boost (output is inverting buffer) 1=1.5x gain boost	Analogue Outputs
	2	SPKBOOST	0	Speaker output boost stage control (see Table 39 for details) 0=No boost (outputs are inverting buffers) 1 = 1.5x gain boost	Analogue Outputs
	1	TSDEN	1	Thermal Shutdown Enable 0 : thermal shutdown disabled 1 : thermal shutdown enabled	Output Switch
	0	VROI	0	VREF (AVDD/2 or 1.5xAVDD/2) to analogue output resistance 0: approx 1kΩ 1: approx 30 kΩ	Analogue Outputs
50 (32h)	8:6		000	Reserved	
	5	AUX2SPK	0	Output of auxiliary amplifier to speaker mixer input 0 = not selected 1 = selected	Analogue Outputs
	4:2		000	Reserved	
	1	BYP2SPK	0	Bypass path (output of input boost stage) to speaker mixer input 0 = not selected 1 = selected	Analogue Outputs
	0	DAC2SPK	0	Output of DAC to speaker mixer input 0 = not selected 1 = selected	Analogue Outputs

REGISTER ADDRESS	BIT	LABEL	DEFAULT	DESCRIPTION	REFER TO
54 (36h)	8				
	7	SPKZC	0	Speaker Volume control zero cross enable: 1 = Change gain on zero cross only 0 = Change gain immediately	Analogue Outputs
	6	SPKMUTE	0	Speaker output mute enable 0=Speaker output enabled 1=Speaker output muted (VMIDOP)	Analogue Outputs
	5:0	SPKVOL	111001	Speaker Volume Adjust 111111 = +6dB 111110 = +5dB ... (1.0 dB steps) 111001=0dB ... 000000=-57dB	Analogue Outputs
56 (38h)	8:7		0	Reserved	
	6	MONOMUTE	0	MONOOUT Mute Control 0=No mute 1=Output muted. During mute the mono output will output VMID which can be used as a DC reference for a headphone out.	Analogue Outputs
	5:3		0	Reserved	
	2	AUX2MONO	0	Output of Auxillary amplifier to mono mixer input: 0 = not selected 1 = selected	Analogue Outputs
	1	BYP2MONO	0	Bypass path (output of input boost stage) to mono mixer input 0 = non selected 1 = selected	Analogue Outputs
	0	DAC2MONO	0	Output of DAC to mono mixer input 0 = not selected 1 = selected	Analogue Outputs

DIGITAL FILTER CHARACTERISTICS

PARAMETER	TEST CONDITIONS	MIN	TYP	MAX	UNIT
ADC Filter					
Passband	+/- 0.025dB	0		0.454fs	
	-6dB		0.5fs		
Passband Ripple				+/- 0.025	dB
Stopband		0.546fs			
Stopband Attenuation	f > 0.546fs	-60			dB
Group Delay			21/fs		
ADC High Pass Filter					
High Pass Filter Corner Frequency	-3dB		3.7		Hz
	-0.5dB		10.4		
	-0.1dB		21.6		
DAC Filter					
Passband	+/- 0.035dB	0		0.454fs	
	-6dB		0.5fs		
Passband Ripple				+/-0.035	dB
Stopband		0.546fs			
Stopband Attenuation	f > 0.546fs	-80			dB
Group Delay			29/fs		

Table 65 Digital Filter Characteristics

TERMINOLOGY

1. Stop Band Attenuation (dB) – the degree to which the frequency spectrum is attenuated (outside audio band)
2. Pass-band Ripple – any variation of the frequency response in the pass-band region
3. Note that this delay applies only to the filters and does not include additional delays through other digital circuits. See Table 66 for the total delay.

PARAMETER	TEST CONDITIONS	MIN	TYP	MAX	UNIT
ADC Path Group Delay					
Total Delay (ADC analogue input to digital audio interface output)	EQ disabled	26/fs	28/fs	30/fs	
	EQ enabled	27/fs	29/fs	31/fs	
DAC Path Group Delay					
Total Delay (Audio interface input to DAC analogue output)	EQ disabled	34/fs	36/fs	38/fs	
	EQ enabled	35/fs	37/fs	39/fs	

Table 66 Total Group Delay

Notes:

1. Wind noise filter is disabled.

DAC FILTER RESPONSES

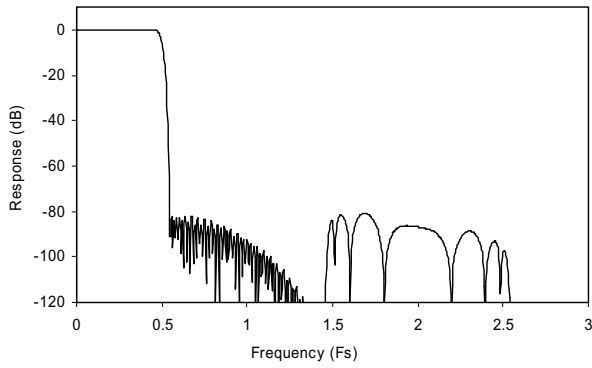

Figure 36 DAC Digital Filter Frequency Response

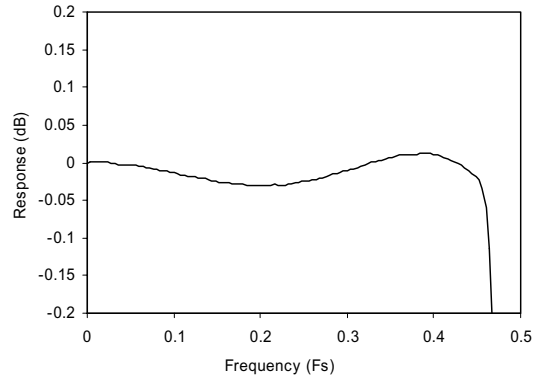

Figure 37 DAC Digital Filter Ripple

ADC FILTER RESPONSES

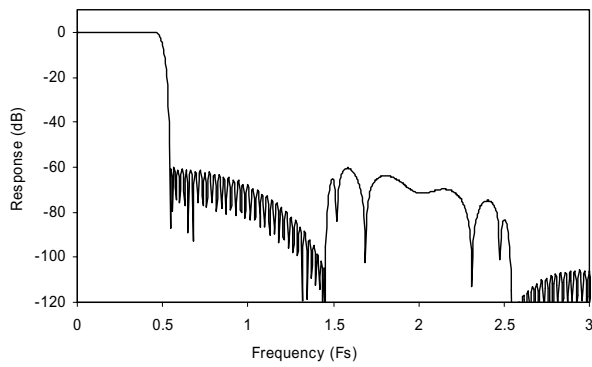

Figure 38 ADC Digital Filter Frequency Response

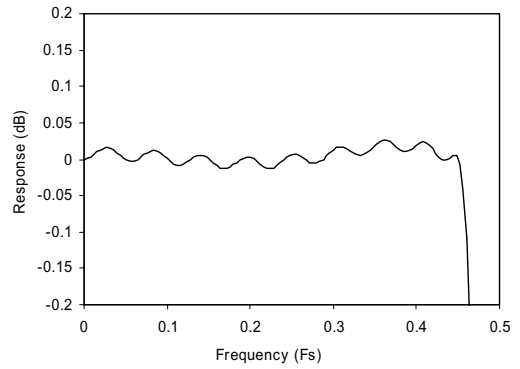

Figure 39 ADC Digital Filter Ripple

DE-EMPHASIS FILTER RESPONSES

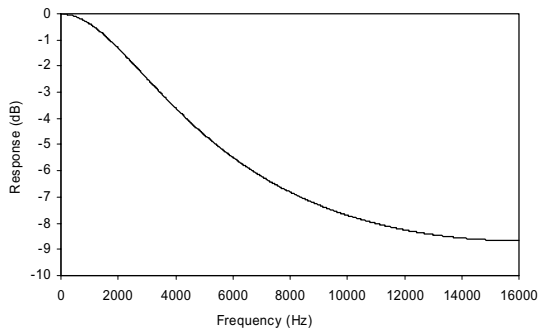

Figure 40 De-emphasis Frequency Response (32kHz)

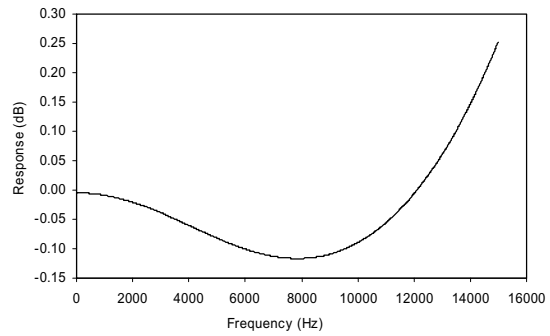

Figure 41 De-emphasis Error (32kHz)

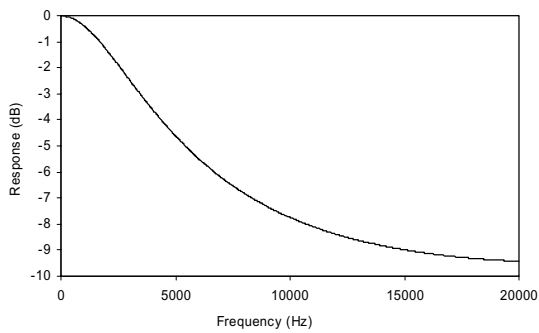

Figure 42 De-emphasis Frequency Response (44.1kHz)

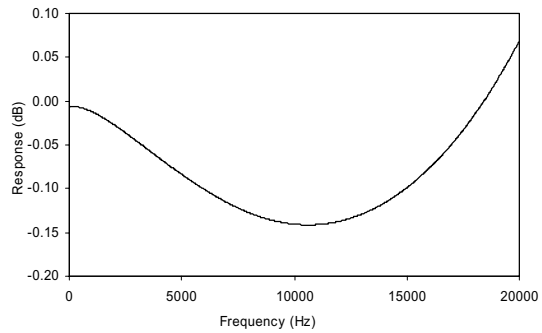

Figure 43 De-emphasis Error (44.1kHz)

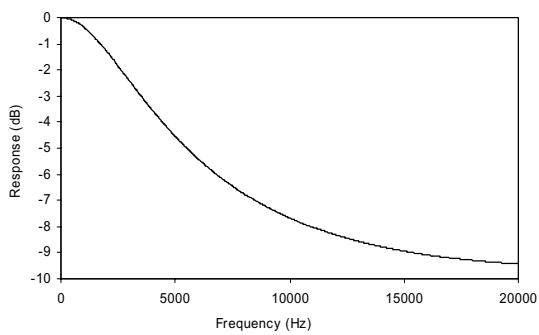

Figure 44 De-emphasis Frequency Response (48kHz)

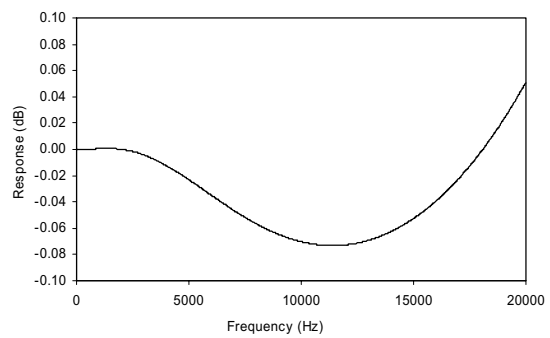

Figure 45 De-emphasis Error (48kHz)

HIGHPASS FILTER

The WM8974 has a selectable digital highpass filter in the ADC filter path. This filter has two modes, audio and applications. In audio mode the filter is a 1st order IIR with a cutoff of around 3.7Hz. In applications mode the filter is a 2nd order high pass filter with a selectable cutoff frequency.

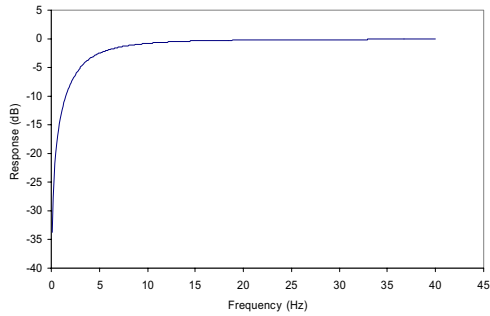

Figure 46 ADC Highpass Filter Response, HPFAPP=0

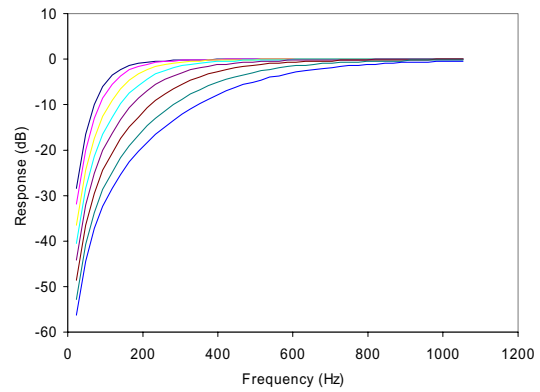

Figure 47 ADC Highpass Filter Responses (48kHz), HPFAPP=1, all cutoff settings shown.

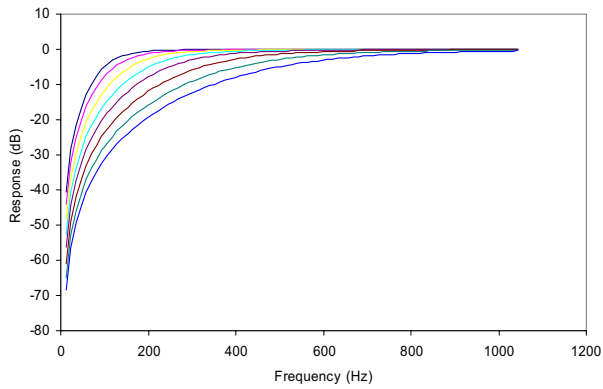

Figure 48 ADC Highpass Filter Responses (24kHz), HPFAPP=1, all cutoff settings shown.

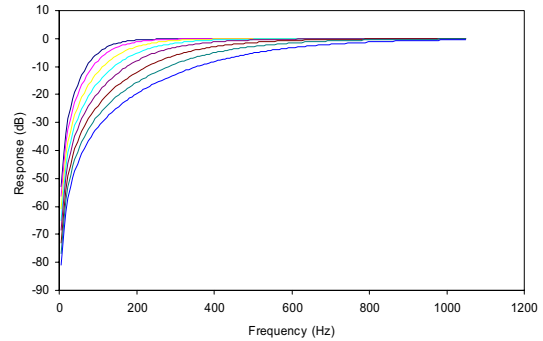

Figure 49 ADC Highpass Filter Responses (12kHz), HPFAPP=1, all cutoff settings shown.

5-BAND EQUALISER

The WM8974 has a 5-band equaliser which can be applied to either the ADC path or the DAC path. The plots from Figure 50 to Figure 63 show the frequency responses of each filter with a sampling frequency of 48kHz, firstly showing the different cut-off/centre frequencies with a gain of $\pm 12\text{dB}$, and secondly a sweep of the gain from -12dB to $+12\text{dB}$ for the lowest cut-off/centre frequency of each filter.

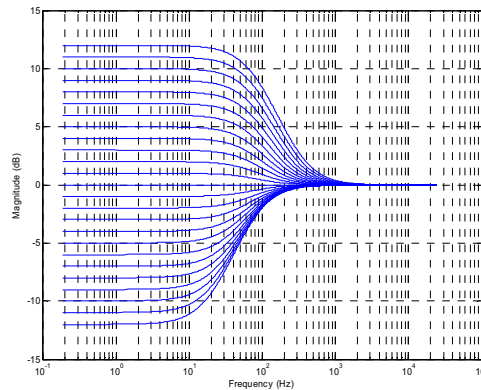
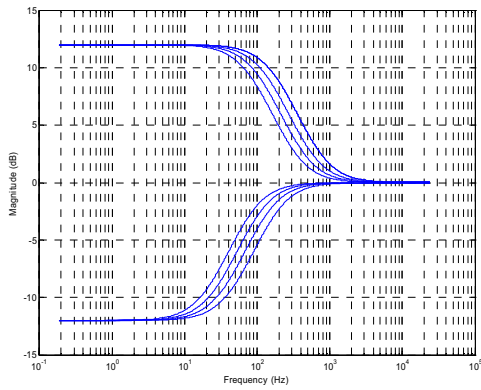

Figure 50 EQ Band 1 – Low Frequency Shelf Filter Cut-offs Figure 51 EQ Band 1 – Gains for Lowest Cut-off Frequency

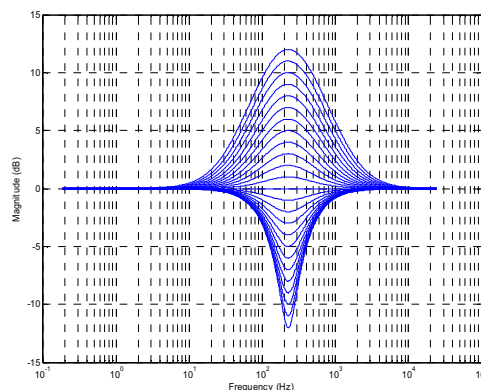
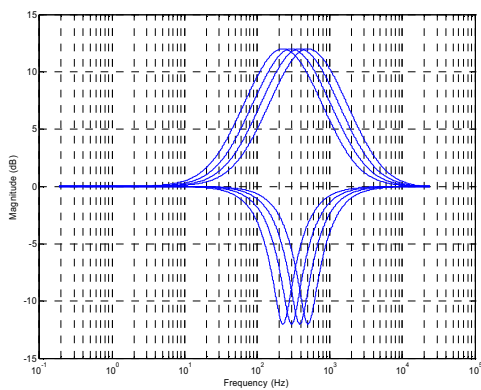

Figure 52 EQ Band 2 – Peak Filter Centre Frequencies, EQ2BW=0

Figure 53 EQ Band 2 – Peak Filter Gains for Lowest Cut-off Frequency, EQ2BW=0

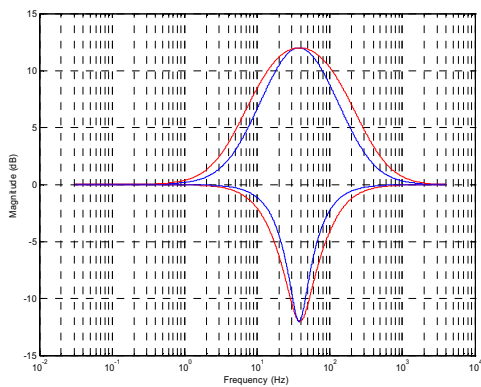

Figure 54 EQ Band 2 – EQ2BW=0, EQ2BW=1

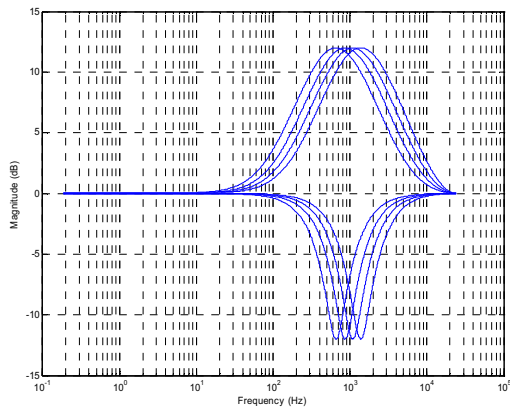

Figure 55 EQ Band 3 – Peak Filter Centre Frequencies, EQ3BW=0

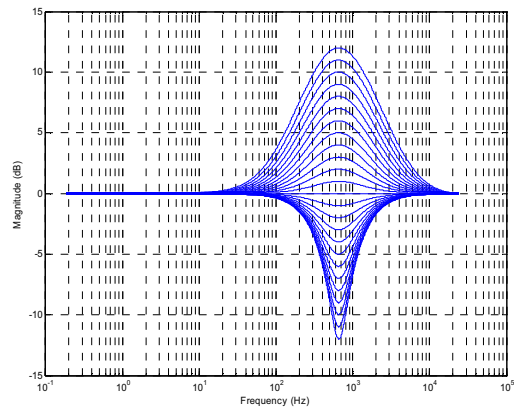

Figure 56 EQ Band 3 – Peak Filter Gains for Lowest Cut-off Frequency, EQ3BW=0

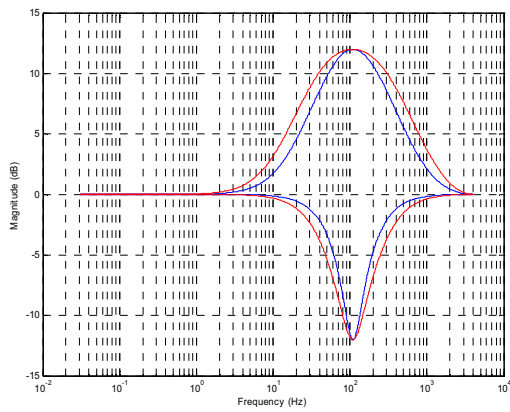

Figure 57 EQ Band 3 – EQ3BW=0, EQ3BW=1

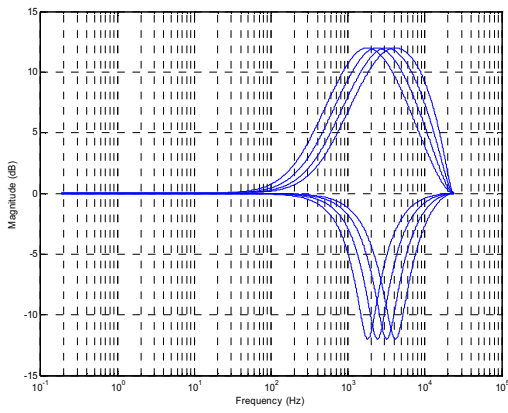

Figure 58 EQ Band 4 – Peak Filter Centre Frequencies, EQ3BW=0

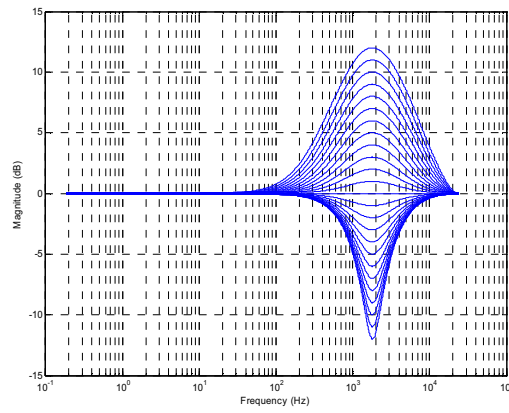

Figure 59 EQ Band 4 – Peak Filter Gains for Lowest Cut-off Frequency, EQ4BW=0

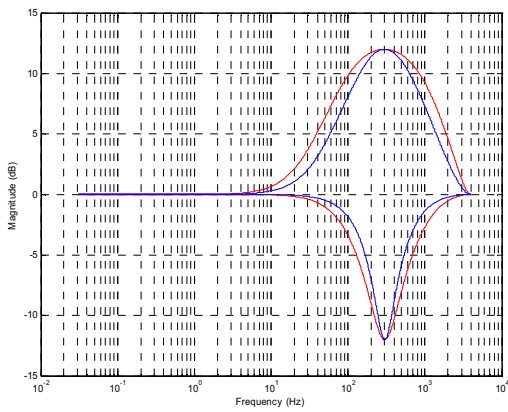

Figure 60 EQ Band 4 – EQ3BW=0, EQ3BW=1

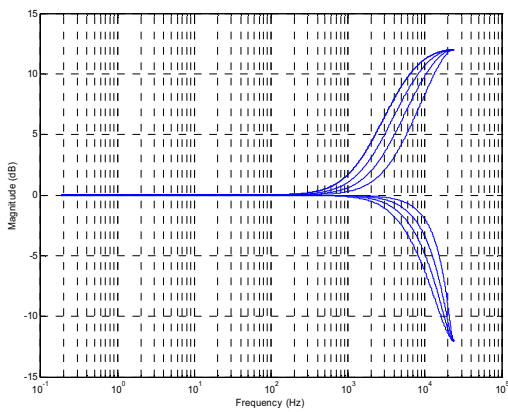

Figure 61 EQ Band 5 – High Frequency Shelf Filter Cut-offs

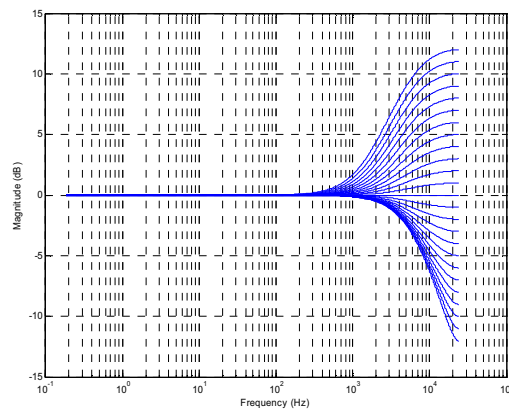

Figure 62 EQ Band 5 – Gains for Lowest Cut-off Frequency

Figure 63 shows the result of having the gain set on more than one channel simultaneously. The blue traces show each band (lowest cut-off/centre frequency) with $\pm 12\text{dB}$ gain. The red traces show the cumulative effect of all bands with $+12\text{dB}$ gain and all bands -12dB gain, with $\text{EQxBW}=0$ for the peak filters.

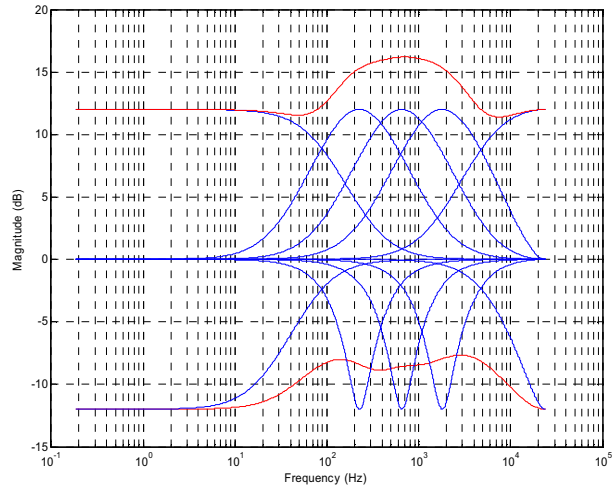

Figure 63 Cumulative Frequency Boost/Cut

APPLICATIONS INFORMATION

RECOMMENDED EXTERNAL COMPONENTS

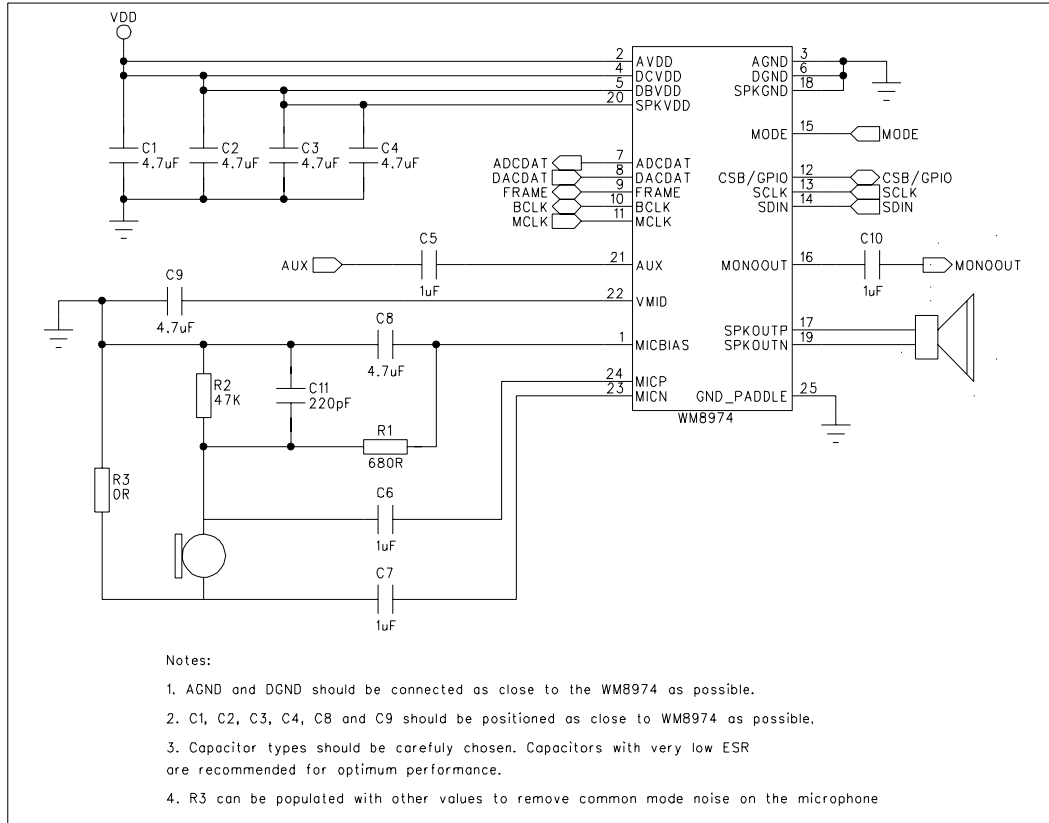
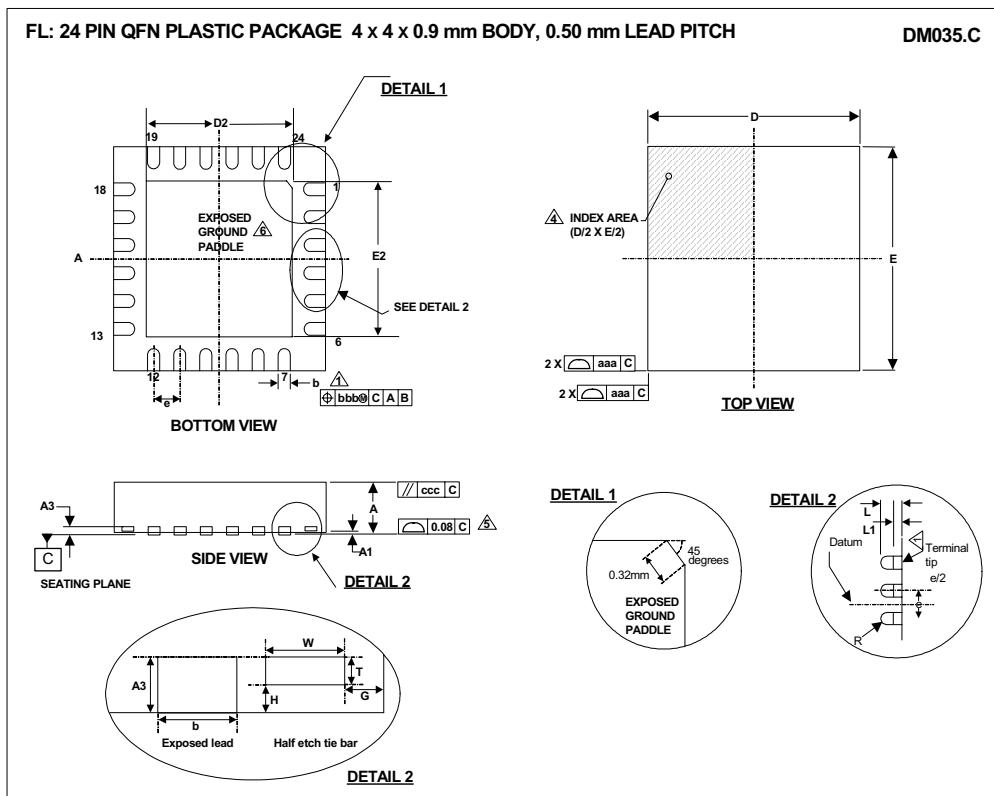

Figure 64 Recommended External Components

PACKAGE DIAGRAM



Symbols	Dimensions (mm)			
	MIN	NOM	MAX	NOTE
A	0.80	0.90	1.00	
A1	0	0.02	0.05	
A3		0.20 REF		
b	0.18	0.25	0.30	1
D		4.00		
D2	2.00	2.15	2.25	2
E		4.00		
E2	2.00	2.15	2.25	2
e		0.50 BSC		
G		0.213		
H		0.1		
L	0.30	0.40	0.50	
L1	0.03		0.15	7
T		0.1		
W		0.2		
Tolerances of Form and Position				
aaa		0.15		
bbb		0.10		
ccc		0.10		
REF:	JEDEC, MO-220, VARIATION VGGD-2.			

- NOTES:**
1. DIMENSION b APPLIES TO METALLIZED TERMINAL AND IS MEASURED BETWEEN 0.15 mm AND 0.30 mm FROM TERMINAL TIP.
 2. FALLS WITHIN JEDEC, MO-220, VARIATION VGGD-2.
 3. ALL DIMENSIONS ARE IN MILLIMETRES.
 4. THE TERMINAL #1 IDENTIFIER AND TERMINAL NUMBERING CONVENTION SHALL CONFORM TO JEDEC 95-1 SPP-002.
 5. COPLANARITY APPLIES TO THE EXPOSED HEAT SINK SLUG AS WELL AS THE TERMINALS.
 6. REFER TO APPLICATIONS NOTE WAN_0118 FOR FURTHER INFORMATION REGARDING PCB FOOTPRINTS AND QFN PACKAGE SOLDERING.
 7. DEPENDING ON THE METHOD OF LEAD TERMINATION AT THE EDGE OF THE PACKAGE, PULL BACK (L1) MAY BE PRESENT.
 8. THIS DRAWING IS SUBJECT TO CHANGE WITHOUT NOTICE.

IMPORTANT NOTICE

Wolfson Microelectronics plc (WM) reserve the right to make changes to their products or to discontinue any product or service without notice, and advise customers to obtain the latest version of relevant information to verify, before placing orders, that information being relied on is current. All products are sold subject to the WM terms and conditions of sale supplied at the time of order acknowledgement, including those pertaining to warranty, patent infringement, and limitation of liability.

WM warrants performance of its products to the specifications applicable at the time of sale in accordance with WM's standard warranty. Testing and other quality control techniques are utilised to the extent WM deems necessary to support this warranty. Specific testing of all parameters of each device is not necessarily performed, except those mandated by government requirements.

In order to minimise risks associated with customer applications, adequate design and operating safeguards must be used by the customer to minimise inherent or procedural hazards. Wolfson products are not authorised for use as critical components in life support devices or systems without the express written approval of an officer of the company. Life support devices or systems are devices or systems that are intended for surgical implant into the body, or support or sustain life, and whose failure to perform when properly used in accordance with instructions for use provided, can be reasonably expected to result in a significant injury to the user. A critical component is any component of a life support device or system whose failure to perform can be reasonably expected to cause the failure of the life support device or system, or to affect its safety or effectiveness.

WM assumes no liability for applications assistance or customer product design. WM does not warrant or represent that any license, either express or implied, is granted under any patent right, copyright, mask work right, or other intellectual property right of WM covering or relating to any combination, machine, or process in which such products or services might be or are used. WM's publication of information regarding any third party's products or services does not constitute WM's approval, license, warranty or endorsement thereof.

Reproduction of information from the WM web site or datasheets is permissible only if reproduction is without alteration and is accompanied by all associated warranties, conditions, limitations and notices. Representation or reproduction of this information with alteration voids all warranties provided for an associated WM product or service, is an unfair and deceptive business practice, and WM is not responsible nor liable for any such use.

Resale of WM's products or services with statements different from or beyond the parameters stated by WM for that product or service voids all express and any implied warranties for the associated WM product or service, is an unfair and deceptive business practice, and WM is not responsible nor liable for any such use.

ADDRESS

Wolfson Microelectronics plc
Westfield House
26 Westfield Road
Edinburgh
EH11 2QB
United Kingdom

Tel :: +44 (0)131 272 7000
Fax :: +44 (0)131 272 7001
Email :: sales@wolfsonmicro.com