

<b>SANYO</b>	No. 4938	<b>STK730-010</b>
	<b>Self-Excitation Type Semi-Regulated Switching Regulator (110W Output)</b>	

## Overview

The STK730-010 incorporates on-chip all the power switching, amplifier, error detection and overcurrent protection circuits required in a self-excitation type semi-regulated off-line switching regulator. As a result, it can be used in the design of switching power supplies with minimal number of external components. Furthermore, the adoption of MOSFET power switching elements supports a higher oscillator frequency than that possible with bipolar transistors. This allows smaller pulse transformers and capacitors to be used, making it possible to construct miniature power supply systems.

## Applications

- CRT/CTV power supplies
- Office automation equipment power supplies

## Features

- Power MOSFET devices
- Ideal for semi-regulated control switching supplies
- Error detection circuit on-chip ( $40.5 \pm 0.5V$  set reference voltage)
- Overcurrent protection circuit on-chip
- Pin compatible with all other devices in the same series of devices with 110 to 280W power ratings
- Higher oscillator frequency allows the use of smaller pulse transformers
- IMST substrate acts as an electromagnetic shield, making low-noise designs possible

## Package Dimensions

unit: mm

4121

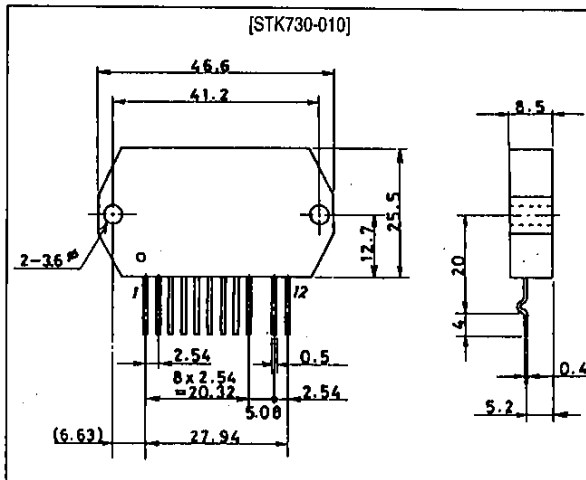

■ No products described or contained herein are intended for use in surgical implants, life-support systems, aerospace equipment, nuclear power control systems, vehicles, disaster/crime-prevention equipment and the like, the failure of which may directly or indirectly cause injury, death or property loss.

■ Anyone purchasing any products described or contained herein for an above-mentioned use shall:

- ① Accept full responsibility and indemnify and defend SANYO ELECTRIC CO., LTD., its affiliates, subsidiaries and distributors and all their officers and employees, jointly and severally, against any and all claims and litigation and all damages, cost and expenses associated with such use:
- ② Not impose any responsibility for any fault or negligence which may be cited in any such claim or litigation on SANYO ELECTRIC CO., LTD., its affiliates, subsidiaries and distributors or any of their officers and employees jointly or severally.

■ Information (including circuit diagrams and circuit parameters) herein is for example only; it is not guaranteed for volume production. SANYO believes information herein is accurate and reliable, but no guarantees are made or implied regarding its use or any infringements of intellectual property rights or other rights of third parties.

**SANYO Electric Co., Ltd. Semiconductor Business Headquarters**  
TOKYO OFFICE Tokyo Bldg., 1-10, 1 Chome, Ueno, Taito-ku, TOKYO, 110 JAPAN

## Block Diagram

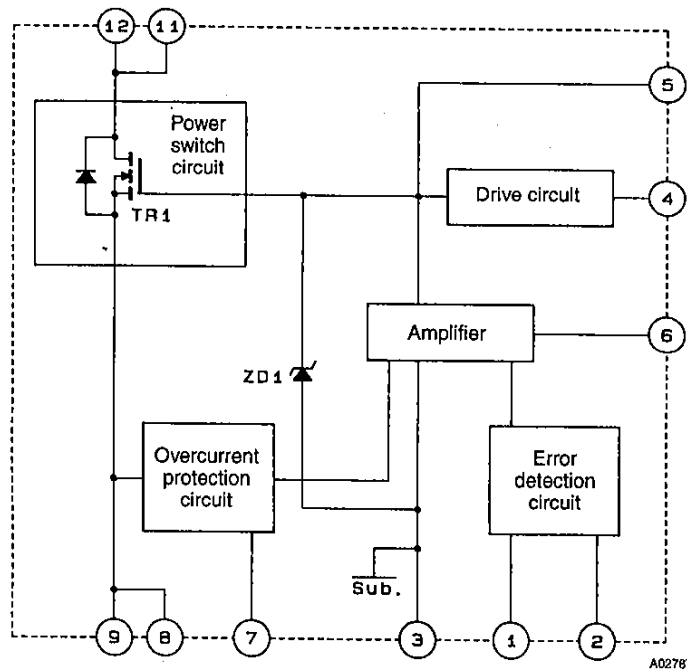

The back surface of the IC is not an insulator, and is effectively at pin 3 potential.

## Pin Functions

Number	Function
1	$V_{ref}$ (40.5V typ) input
2	Error detection level
3	Ground
4	Drive voltage input
5	TR1 gate
6	Amplifier circuit control
7	OCP setting level input
8	TR1 source
9	
11	TR1 drain
12	

## Specifications

**Maximum Ratings** at  $T_a = 25^\circ\text{C}$ ,  $T_c = 25^\circ\text{C}$  unless otherwise specified

Parameter	Symbol	Conditions	Ratings	Unit
Operating substrate temperature	$T_c \text{ max}$	Recommended value is $105^\circ\text{C}$ .	115	$^\circ\text{C}$
AC input voltage	$V_{AC}$	Specified test circuit	140	$V_{rms}$
Operating temperature	$T_{opr}$		-10 to +85	$^\circ\text{C}$
Storage temperature	$T_{stg}$		-30 to +115	$^\circ\text{C}$
Maximum output power	$W_o \text{ max}$	Specified test circuit, $V_o = 135\text{V}$	110	W

STK730-010

Parameter	Symbol	Conditions	Ratings	Unit
<b>[TR1]</b>				
Drain current	$I_D$	Refer to ASO characteristics for overcurrent condition.	6	A
Pulse drain current	$I_{D(pulse)}$		20	A
Drain reverse current	$I_{DR}$		6	A
Gate-source voltage	$V_{GSS}$		$\pm 30$	V
Allowable power dissipation	$P_D$		78.1	W
Chip junction temperature	$T_J \text{ max}$		150	$^{\circ}\text{C}$
Thermal resistance	$\theta_{j-c}$		1.6	$^{\circ}\text{C/W}$
<b>[ZD1]</b>				
Allowable power dissipation	$P_{ZD1}$		500	mW
Chip junction temperature	$T_J(\text{ZD1}) \text{ max}$		125	$^{\circ}\text{C}$
Thermal resistance	$\theta_{j-c}(\text{ZD1})$		0.2	$^{\circ}\text{C/mW}$

**Allowable Operating Ranges** at  $T_a = 25^{\circ}\text{C}$

Parameter	Symbol	Conditions	Ratings	Unit
Pin 4 input voltage	$V_4$		$\pm 8$ to $\pm 24$	V
Oscillator frequency	$f_{osc}$		20 to 120	kHz

**Operating Characteristics** at  $T_a = 25^{\circ}\text{C}$ ,  $T_c = 25^{\circ}\text{C}$  unless otherwise specified, specified test circuit

Parameter	Symbol	Conditions	min	typ	max	Unit
Output voltage setting		$I_{IN} = 8\text{mA}$	40.0	40.5	41.0	V
Output voltage temperature coefficient		$T_c = 0$ to $105^{\circ}\text{C}$ , $I_{IN} = 8\text{mA}$	-	7	-	$\text{mV}/^{\circ}\text{C}$
<b>[TR1]</b>						
Drain-source breakdown voltage	$V_{(BR)DSS}$	$I_D = 10\text{mA}$ , $V_{GS} = 0\text{V}$	500	-	-	V
Gate-source cutoff voltage	$V_{GS(off)}$	$I_D = 1\text{mA}$ , $V_{DS} = 10\text{V}$	2.0	-	3.0	V
ON resistance	$R_{DS(on)}$	$I_D = 2.5\text{A}$ , $V_{GS} = 10\text{V}$	-	1.4	1.8	$\Omega$
Input capacitance	$C_{iss}$	$V_{DS} = 10\text{V}$ , $V_{GS} = 0\text{V}$ , $f = 1\text{MHz}$	-	800	-	pF
<b>[ZD1]</b>						
Zener voltage	$V_Z$	$I_Z = 5\text{mA}$	23.7	-	26.3	V

Circuit Function Diagram

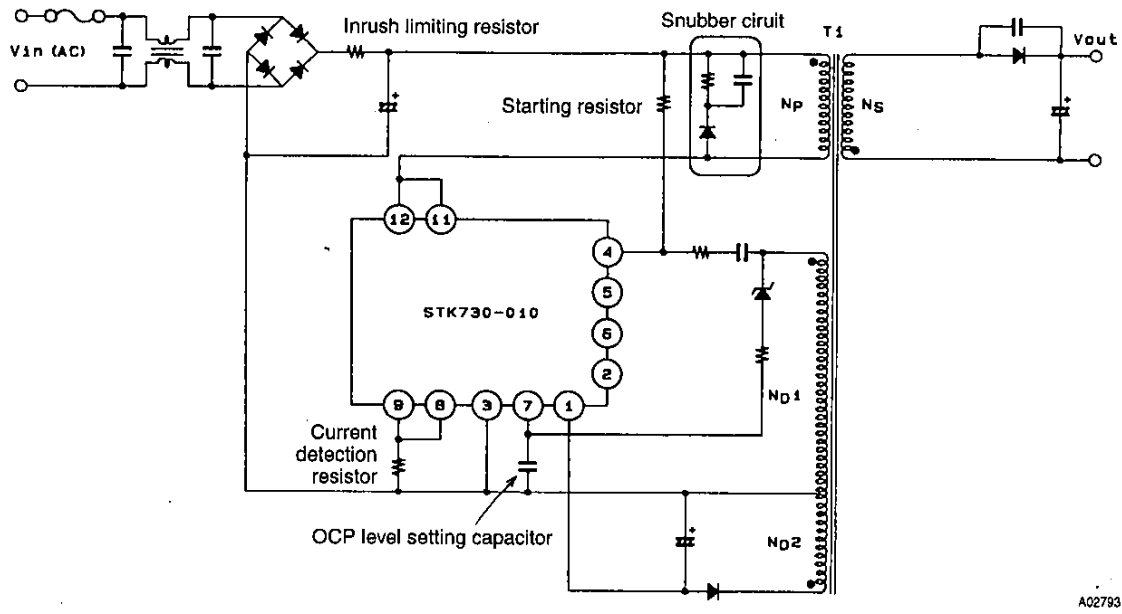

A02793

$P_D - T_c$

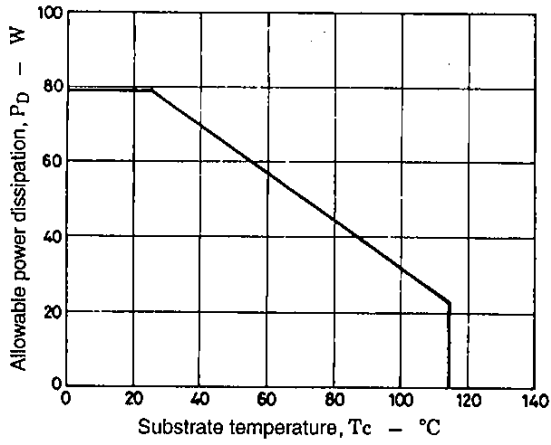

ASO

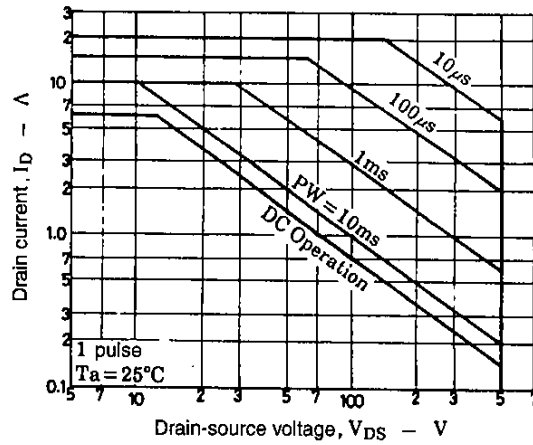

Sample Application Circuit

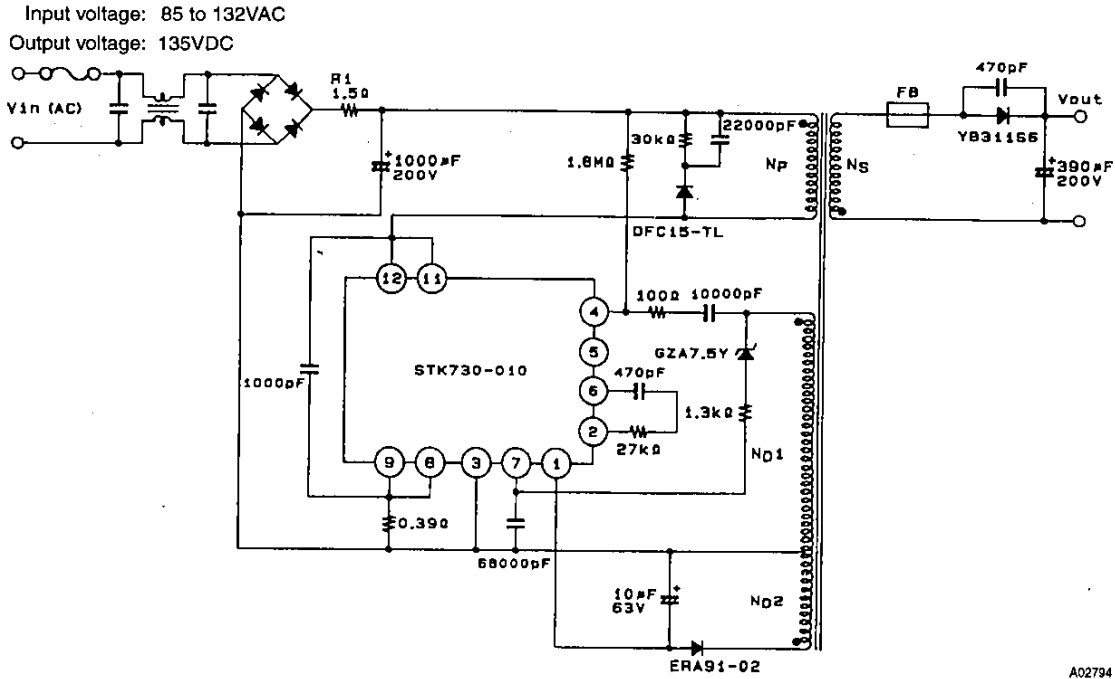

A02794

Pulse Transformer Specifications

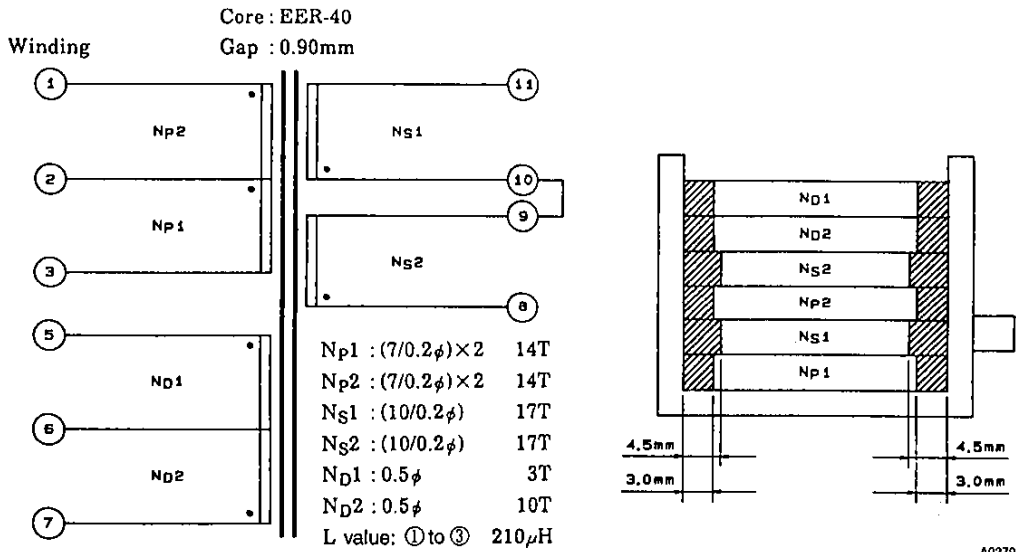

A02795

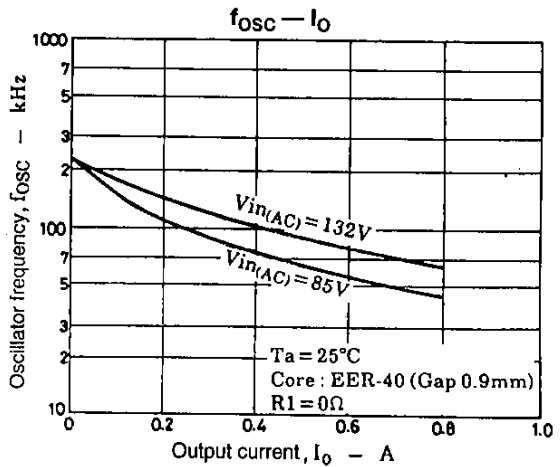
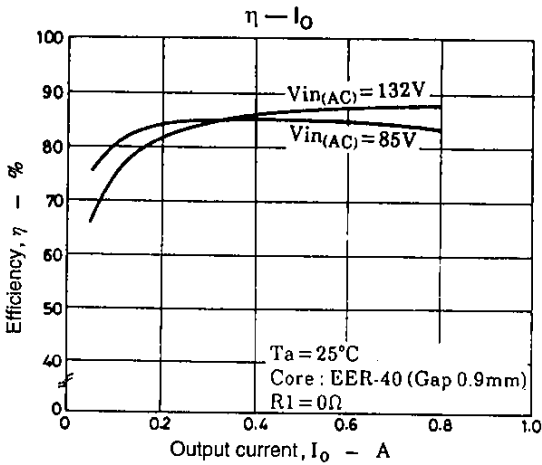
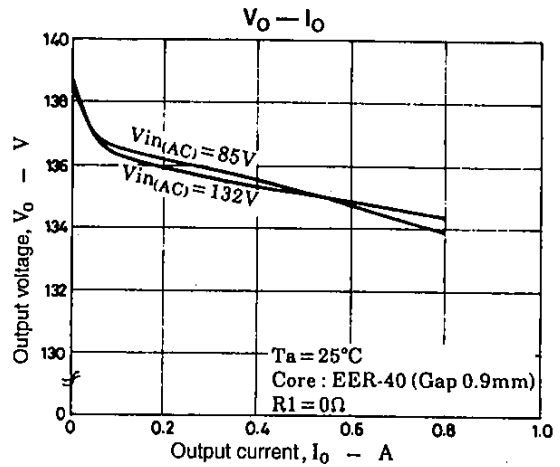
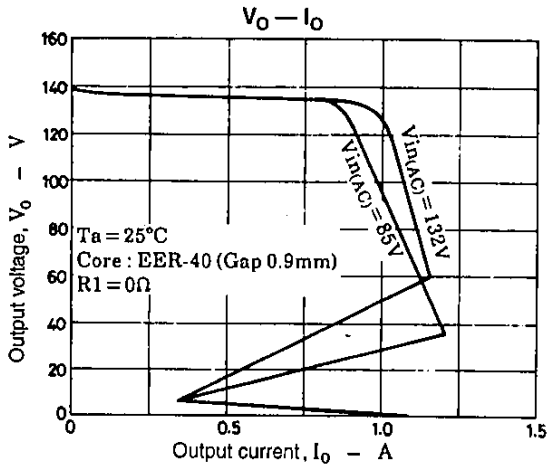

### Series Organization

These devices form a series with varying output power ratings.

Device	Maximum ratings					Operating characteristics		
	$V_{DSS}$ [V]	$T_{stg}$ [°C]	$T_c$ max [°C]	$T_j$ max [°C]	$I_D$ [A]	Input voltage [V]	Output power [W]	ON resistance [Ω]
STK730-010	500	-30 to +115	+115	+150	6.0	85 to 132	110	1.4
STK730-020					8.0		145	0.8
STK730-030					10.0		180	0.7
STK730-040					12.0		210	0.55
STK730-050					15.0		280	0.3
STK730-060	900				3.0	170 to 264	110	5.0
STK730-070					5.0		180	3.0
STK730-080					6.0		210	2.0
STK730-090					8.0		280	1.2