



STK400-290

AF Power Amplifier (Split Power Supply) (50 W + 50 W + 50W min, THD = 0.08%)

Overview

Now, thick-film audio power amplifier ICs are available with pin-compatibility to permit a single PCB to be designed and amplifier output capacity changed simply by installing a hybrid IC. This new series was developed with this kind of pin-compatibility to ensure integration between systems everywhere. With this new series of ICs, even changes from 3-channel amplifier to 2-channel amplifiers is possible using the same PCB. In addition, this new series of ICs has a $6/3\Omega$ drive in order to support the low impedance of modern speakers.

Features

- Pin-compatible
STK400-000 series (3-channel, single package)



- STK401-000 series (2-channel, single package)
- Output load impedance $R_L=6\Omega/3\Omega$ supported
- New pin assignment

To simplify input/output pattern layout and minimize the effects of pattern layout on operational characteristics, pin assignments are grouped into blocks consisting of input, output and power systems.

- Few external circuits
Compared to those series used until now, capacitors and bootstrap resistors for external circuits can be greatly reduced.

Package Dimensions

unit: mm

4086A

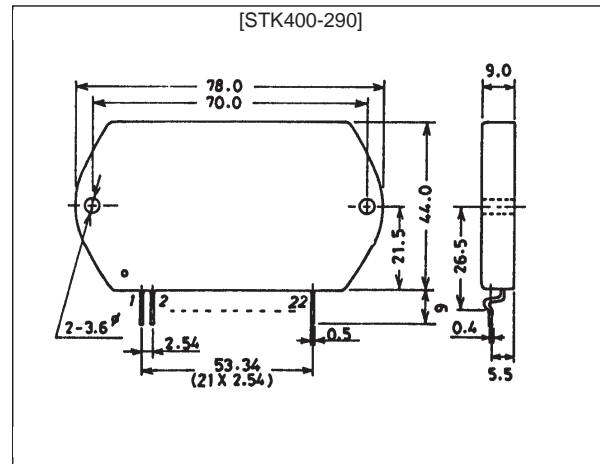

Specifications

Absolute Maximum Ratings at Ta = 25°C

Parameter	Symbol	Conditions	Ratings	Unit
Maximum supply voltage	V _{CC} max		±47	V
Thermal resistance	θ _{j-c}	Per power transistor	1.7	°C/W
Junction temperature	T _j		150	°C
Substrate temperature	T _c		125	°C
Storage temperature	T _{stg}		-30 to +125	°C
Available time for load short-circuit	t _s	V _{CC} = ±32 V, R _L = 6 Ω, f = 50 Hz, P _O = 50 W	1	s

Operating Characteristics at Ta = 25°C, R_L = 6 Ω, R_g = 600 Ω, VG = 40 dB, R_L (non-inductive)

Parameter	Symbol	Conditions	Ratings			Unit
			min	typ	max	
Quiescent current	I _{CCO}	V _{CC} = ±39 V	30	90	150	mA
Output power	P _O (1)	V _{CC} = ±32 V, f = 20 to 20 kHz, THD = 0.08%	50	55		W
	P _O (2)	V _{CC} = ±26 V, f = 1 kHz, THD = 0.2%, R _L = 3 Ω	50	55		W
Total harmonic distortion	THD (1)	V _{CC} = ±32 V, f = 20 to 20 kHz, P _O = 1.0 W			0.08	%
	THD (2)	V _{CC} = ±32 V, f = 1 kHz, P _O = 5.0 W		0.007		%
Frequency response	f _L , f _H	V _{CC} = ±32 V, P _O = 1.0 W, $\frac{0}{-3}$ dB		20 to 50 k		Hz
Input impedance	r _i	V _{CC} = ±32 V, f = 1 kHz, P _O = 1.0 W		55		kΩ
Output noise voltage	V _{NO}	V _{CC} = ±39 V, R _g = 10 kΩ			1.2	mVrms
Neutral voltage	V _N	V _{CC} = ±39 V	-70	0	+70	mV

Notes

- Use rated power supply for testing unless otherwise specified.
- When measuring available time for load short-circuit and output noise voltage, use transformer power supply indicated below.
- Output noise voltage is represented by the peak value rms (VTVM) for mean reading. Use an AC stabilized power supply (50 Hz) on the primary side to eliminate the effect of AC flicker noise.

Specified Transformer Power Supply (MG-200 equivalent)

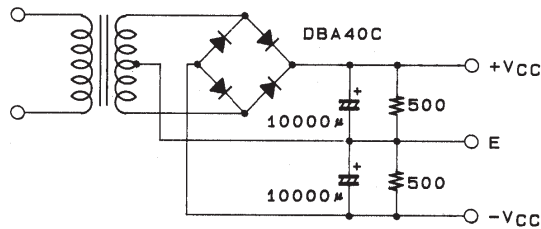

A01361

Unit (resistance: Ω, capacitance: F)

Internal Equivalent Circuit

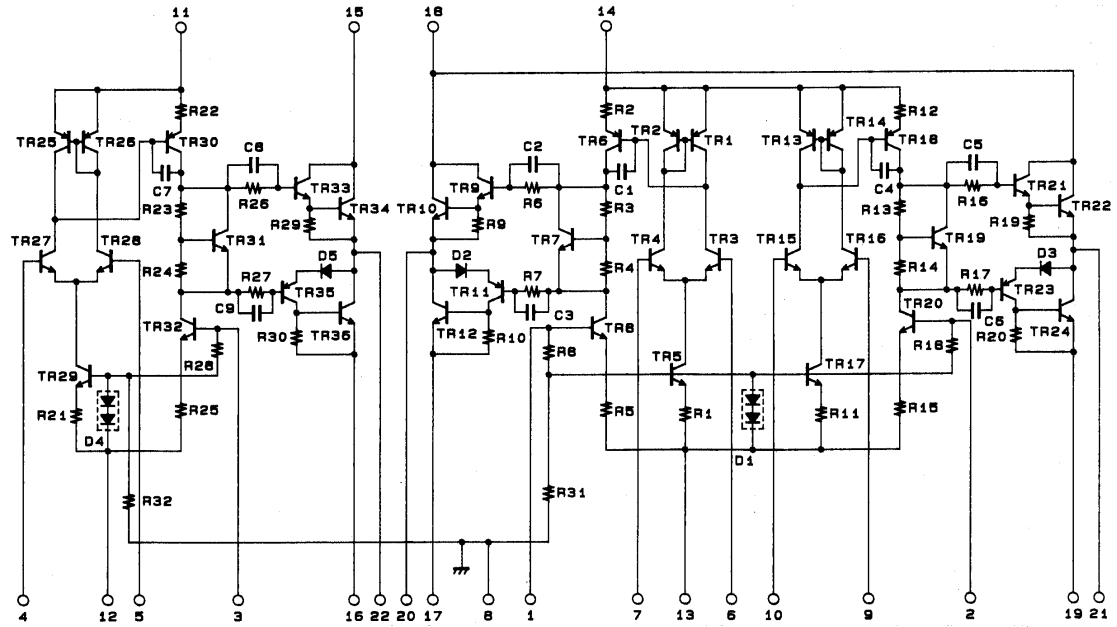

Pattern Example for PCB used with either 2- or 3-channel Amplifiers.

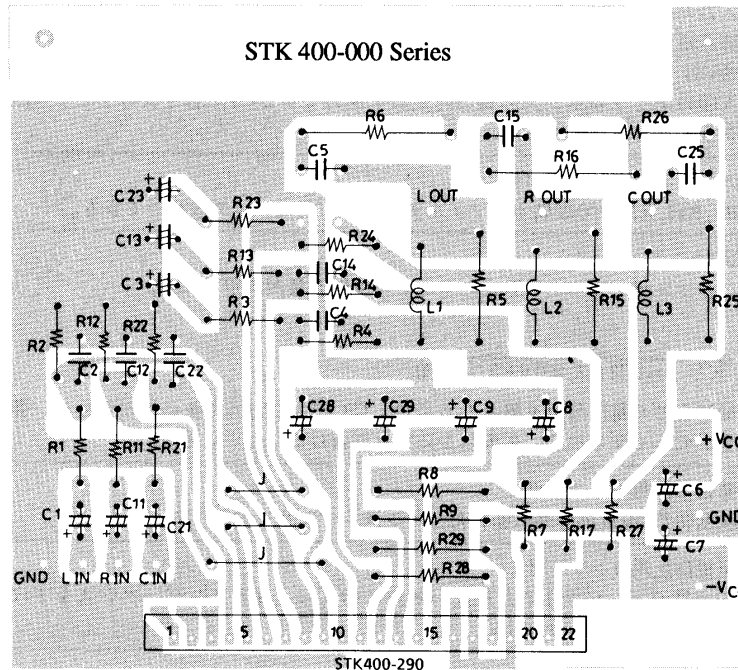

Copper (Cu) foil surface

In the STK401-000 series, pin No. 6 corresponds to pin No. 1.

Sample Application Circuit

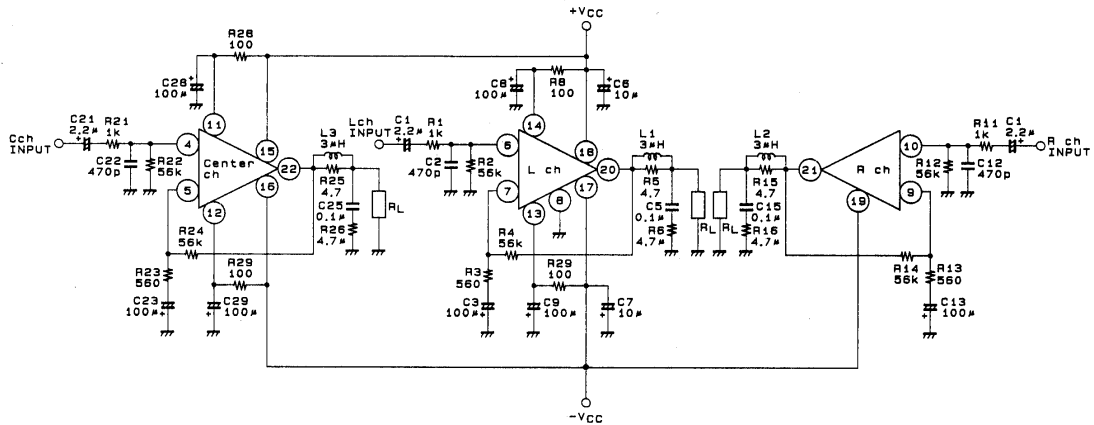

Unit (resistance: Ω, capacitance: F)

Description of External Circuits

C1, 11, 21	For input coupling capacitor. Used for current blocking. When capacitor reactance with low frequency is increased, the reactance value should be reduced in order to reduce the output noise from the signal resistance dependent 1/f noise. In response to the popping noise which occurs when the system power is turned on, C1 and C11 which determine the decay time constant on the input side are increased while C3, C13 and C23 on the NF side are decreased.
C2, 12, 22	For input filter capacitor. Permits high-region noise reduction by utilizing filter constructed with R1, R11 and R21.
C3, 13, 23	For NF capacitor. This capacitor determines the decline of the cutoff frequency and is calculated according to the following equation. $f_L = \frac{1}{2\pi \times C3 (13, 23) \times R3 (13, 23)}$ <p>For the purpose of achieving voltage gains prior to reduction, it is best that C3, C13 and C23 are large. However, because the shock noise which occurs when the system power is turned on tends to increase, values larger than those absolutely necessary should be avoided.</p>
C5, 15, 25	For oscillation prevention capacitor. A Mylar capacitor with temperature and frequency features is recommended.
C6, 7	For oscillation prevention capacitor. To ensure safe IC functioning, the capacitor should be installed as close as possible to the IC power pin to reduce power impedance. An electrolytic capacitor is good.
C8, 9, 28, 29	For decoupling capacitor. Reduces shock noise during power up using decay time constant circuits with R8, R9, R28 and R29 and eliminates components such as ripples crossing over into the input side from the power line.
R1, 11, 21	For input filter applied resistor.
R2, 12, 22	For input bias resistor. The input pin is biased to zero potential. Input impedance is mostly decided with this resistance value.
R3, 13, 23 R4, 14, 24	For resistors to determine voltage gain (VG). We recommend a VG = 40 dB using R3, R13, R23 = 560 Ω and R4, R14 and R24 = 56 Ω. VG adjustments are best performed using R3, R13 and R23. When using R4, R14 and R24 for such purposes, R4, R14 and R24 should be set to equal R2, R12 and R22 in order to establish a stable V _N balance.
R5, 15, 25	For oscillation prevention resistor.
R6, 16, 26	For oscillation prevention resistor. This resistor's electrical output resides in the signal frequency and is calculated according to the following formula. $P_{R6} (16, 26) = \left(\frac{V_{CC} \max^{\sqrt{2}}}{1/2\pi f C5 (15, 25) + R6 (16, 26)} \right)^2 \times R6 (16, 26)$ <p>f = output signal frequency upper limit</p>
R8, 9, 28, 29	For ripple filter applied resistor. P _O max, ripple rejection and power-up shock noise are modified according to this value. Set the electrical output of these resistors while keeping in mind the flow of peak current during recharging to C8, C9, C28 and C29 which function as pre-drive TR control resistors during load shorts.
L1, 2, 3	For oscillation prevention coil. Compensates phase dislocation caused by load capacitors and ensures stable oscillation.

STK400-290

Series Configuration

STK400-000, STK400-200 series (3 ch simultaneous)					STK401-000, STK401-200 series (2 ch)					Supply voltage (V)			
Type No.	THD (%)	Type No.	THD (%)	Fixed standard output	Type No.	THD (%)	Type No.	THD (%)	Fixed standard output	V _{CC} max1	V _{CC} max2	V _{CC} 1	V _{CC} 2
STK400-010	0.4	STK400-210	0.08	10 W × 3	STK401-010	0.4	STK401-210	0.08	10 W × 2	—	±26.0	±17.5	±14.0
STK400-020		STK400-220		15 W × 3	STK401-020		STK401-220		15 W × 2	—	±29.0	±20.0	±16.0
STK400-030		STK400-230		20 W × 3	STK401-030		STK401-230		20 W × 2	—	±34.0	±23.0	±19.0
STK400-040		STK400-240		25 W × 3	STK401-040		STK401-240		25 W × 2	—	±36.0	±25.0	±21.0
STK400-050		STK400-250		30 W × 3	STK401-050		STK401-250		30 W × 2	—	±39.0	±26.0	±22.0
STK400-060		STK400-260		35 W × 3	STK401-060		STK401-260		35 W × 2	—	±41.0	±28.0	±23.0
STK400-070		STK400-270		40 W × 3	STK401-070		STK401-270		40 W × 2	—	±44.0	±30.0	±24.0
STK400-080		STK400-280		45 W × 3	STK401-080		STK401-280		45 W × 2	—	±45.0	±31.0	±25.0
STK400-090		STK400-290		50 W × 3	STK401-090		STK401-290		50 W × 2	—	±47.0	±32.0	±26.0
STK400-100		STK400-300		60 W × 3	STK401-100		STK401-300		60 W × 2	—	±51.0	±35.0	±27.0
STK400-110		STK400-310		70 W × 3	STK401-110		STK401-310		70 W × 2	±56.0	—	±38.0	—
				STK401-120	STK401-320	80 W × 2	±61.0	—	±42.0	—			
				STK401-130	STK401-330	100 W × 2	±65.0	—	±45.0	—			
				STK401-140	STK401-340	120 W × 2	±74.0	—	±51.0	—			

STK400-400, STK400-600 series (3 ch non-simultaneous)					Supply voltage (V)			
Type No.	THD (%)	Type No.	THD (%)	Fixed standard output	V _{CC} max1	V _{CC} max2	V _{CC} 1	V _{CC} 2
STK400-450	0.4	STK400-650	0.08	C ch 30 W	—	±39.0	±26.0	±22.0
				L, R ch 15 W	—	±29.0	±20.0	±16.0
STK400-460		STK400-660		C ch 35 W	—	±41.0	±28.0	±23.0
				L, R ch 15 W	—	±29.0	±20.0	±16.0
STK400-470		STK400-670		C ch 40 W	—	±44.0	±30.0	±24.0
				L, R ch 20 W	—	±34.0	±23.0	±19.0
STK400-480		STK400-680		C ch 45 W	—	±45.0	±31.0	±25.0
				L, R ch 20 W	—	±34.0	±23.0	±19.0
STK400-490		STK400-690		C ch 50 W	—	±47.0	±32.0	±26.0
				L, R ch 25 W	—	±36.0	±25.0	±21.0
STK400-500		STK400-700		C ch 60 W	—	±51.0	±35.0	±27.0
	L, R ch 30 W		—	±39.0	±26.0	±22.0		
STK400-510	STK400-710	C ch 70 W	±56.0	—	±38.0	—		
		L, R ch 35 W	—	±41.0	±28.0	±23.0		
STK400-520	STK400-720	C ch 80 W	±61.0	—	±42.0	—		
		L, R ch 40 W	—	±44.0	±30.0	±24.0		
STK400-530	STK400-730	C ch 100 W	±65.0	—	±45.0	—		
		L, R ch 50 W	—	±47.0	±32.0	±26.0		

V_{CC} max1 R_L = 6 Ω
 V_{CC} max2 R_L = 3 Ω to 6 Ω operation
 V_{CC}1 R_L = 6 Ω operation
 V_{CC}2 R_L = 3 Ω operation

Example of Set Design for Common PCB

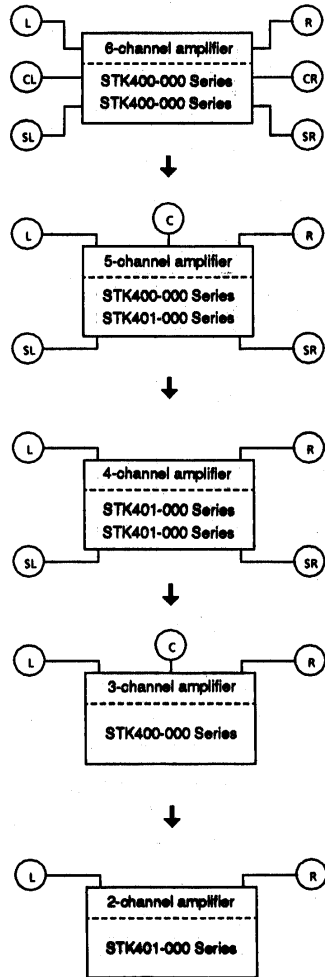

External Circuit Diagram

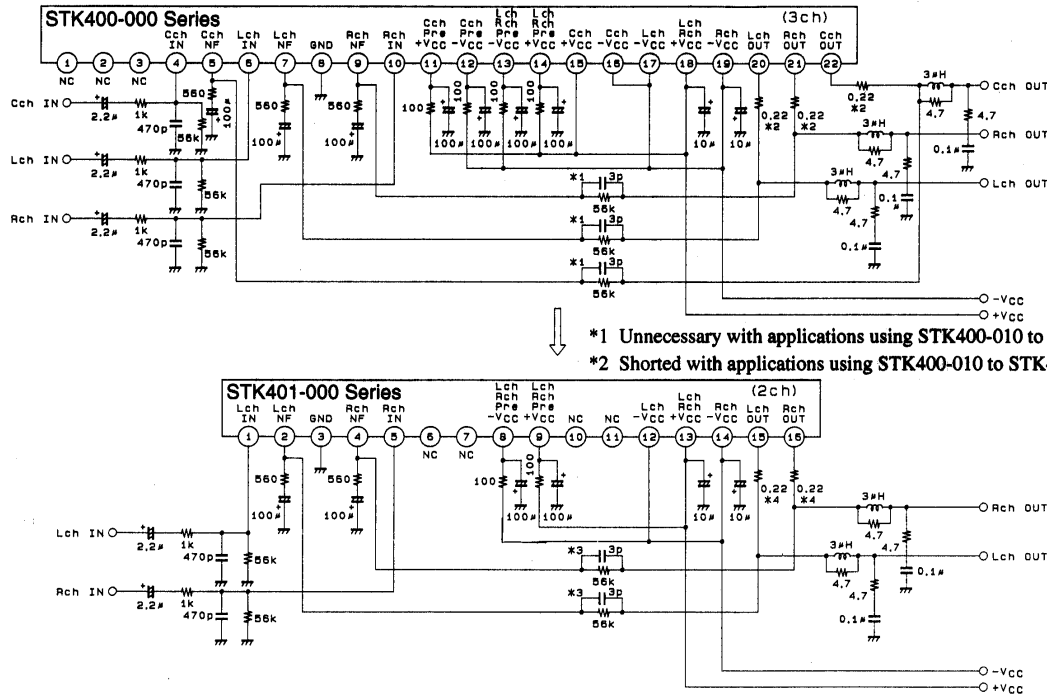

*1 Unnecessary with applications using STK400-010 to STK400-090.
 *2 Shorted with applications using STK400-010 to STK400-090.

*3 Unnecessary with applications using STK401-010 to STK401-090.
 *4 Shorted with applications using STK401-010 to STK401-090.

Unit (resistance:Ω, capacitance:F)

Heat Radiation Design Considerations

The radiator thermal resistance θ_{c-a} required for total substrate power dissipation P_d in the STK400-290 is determined as:

Condition 1: IC substrate temperature T_c not to exceed 125°C.

$$P_d \times \theta_{c-a} + T_a < 125^\circ\text{C} \dots\dots\dots (1)$$

where T_a is the assured ambient temperature.

Condition 2: Power transistor junction temperature T_j not to exceed 150°C.

$$P_d \times \theta_{c-a} + P_d/N \times \theta_{j-c} + T_a < 150^\circ\text{C} \dots\dots(2)$$

where N is the number of power transistors and θ_{j-c} the thermal resistance per power transistor chip. However, power transistor power consumption is P_d equally divided by N units.

Expressions (1) and (2) can be rewritten based on θ_{c-a} to yield:

$$\theta_{c-a} < (125 - T_a) / P_d \dots\dots\dots(1')$$

$$\theta_{c-a} < (150 - T_a) / P_d - \theta_{j-c} / N \dots\dots\dots(2')$$

The required radiator thermal resistance will satisfy both of these expressions.

From expressions (1)' and (2)', the required radiator thermal resistance can be determined once the following specifications are known:

- Supply voltage V_{CC}
- Load resistance R_L
- Assured ambient temperature T_a

The total substrate power consumption when STK400-290 V_{CC} is ± 32 V and R_L is 6 Ω, for a continuous sine wave signal, is a maximum of 105 W (Figure. 1). In general, when this sort of continuous signal is used for estimation of power consumption, the P_d used is 1/10th of P_o max (slight variation depending on safety standard).

$$P_d = 66.5 \text{ W (1/10 } P_o \text{ max=during 5 W)}$$

The STK400-290 has six power transistors, so the thermal resistance per transistor θ_{j-c} is $1.7^{\circ}\text{C} / \text{W}$. With an assured ambient temperature T_a of 50°C , the required radiator thermal resistance θ_{c-a} would be:

$$\begin{aligned} \text{From expression (1)'} \quad \theta_{c-a} &< (125-50)/66.5 \\ &< 1.12 \\ \text{From expression (2)'} \quad \theta_{c-a} &< (150-50)/66.5 - 1.7/6 \\ &< 1.22 \end{aligned}$$

To satisfy both, $1.12^{\circ}\text{C}/\text{W}$ is the required radiator thermal resistance.

Figure 2 illustrates $P_d - P_o$ when the V_{CC} of STK400-290 is $\pm 26 \text{ V}$ and R_L is functioning at 3Ω .

$$\begin{aligned} P_d &= 76 \text{ W} \text{ (1/10 } P_o \text{ max = during 5 W)} \\ \text{From expression (1)'} \quad \theta_{c-a} &< (125-50)/76 \\ &< 0.98 \\ \text{From expression (2)'} \quad \theta_{c-a} &< (150-50)/76 - 1.7/6 \\ &< 1.03 \end{aligned}$$

To satisfy both, $0.98^{\circ}\text{C} / \text{W}$ is the required radiator thermal resistance. This design example is based on a fixed voltage supply, and will require verification within your specific set environment.

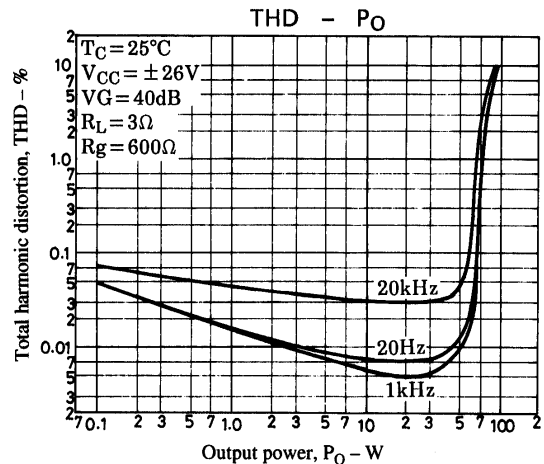
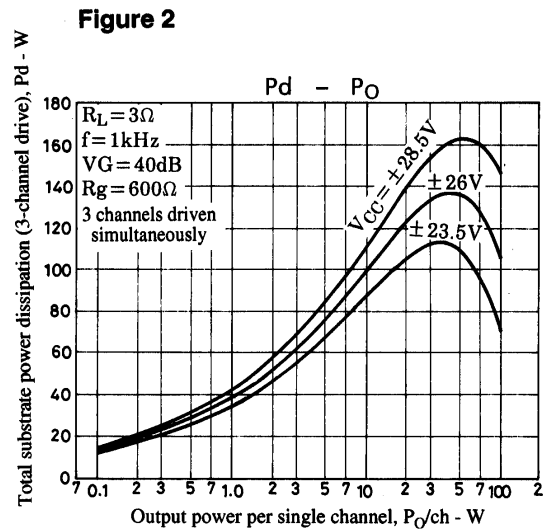
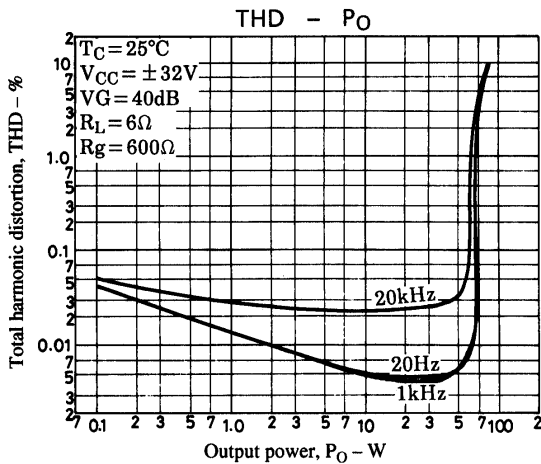
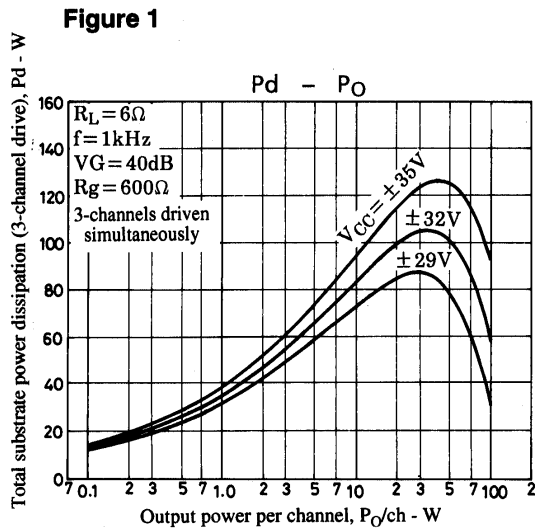

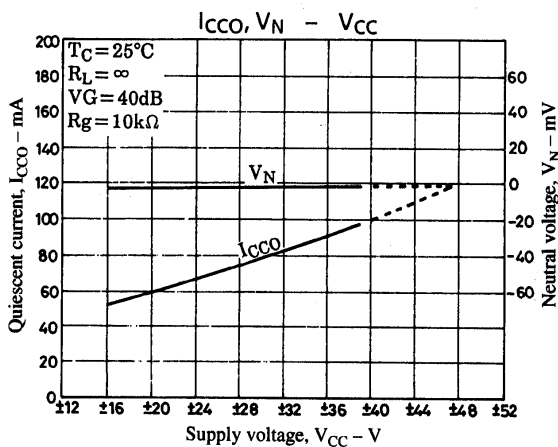
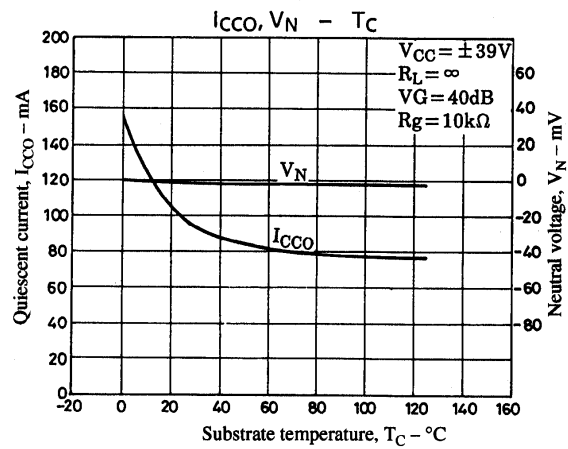
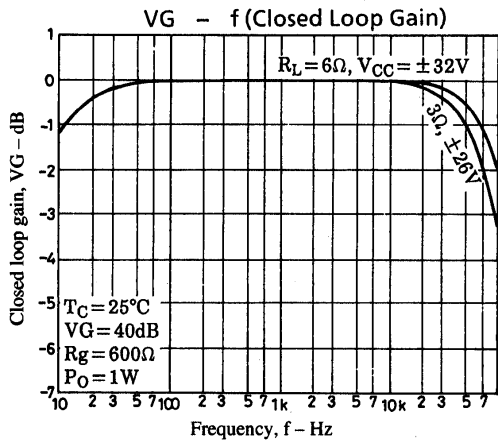
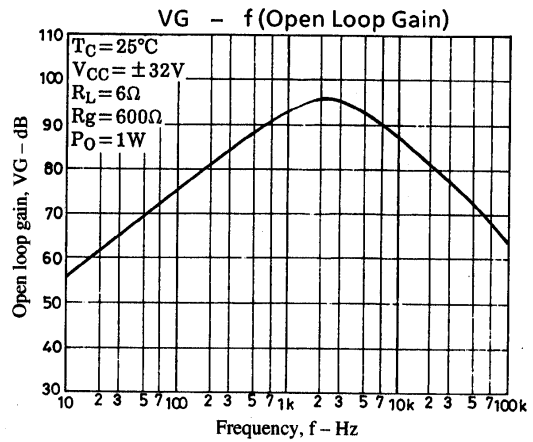
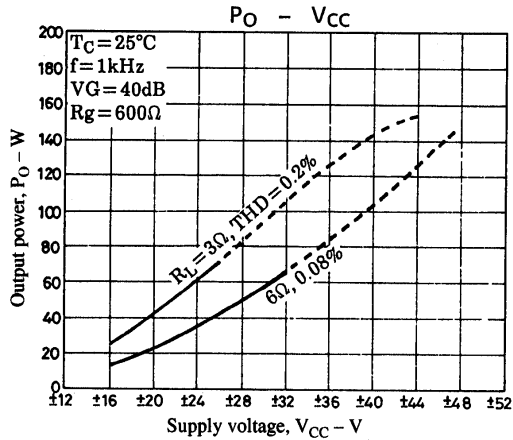
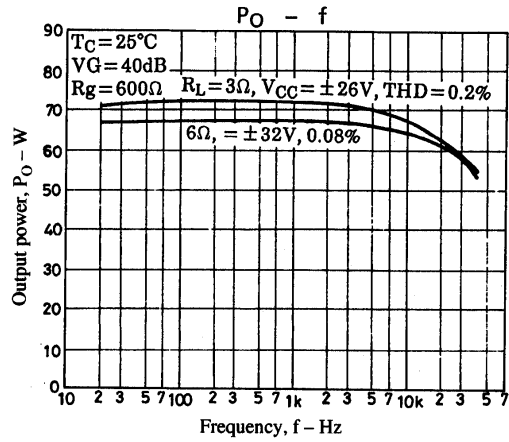
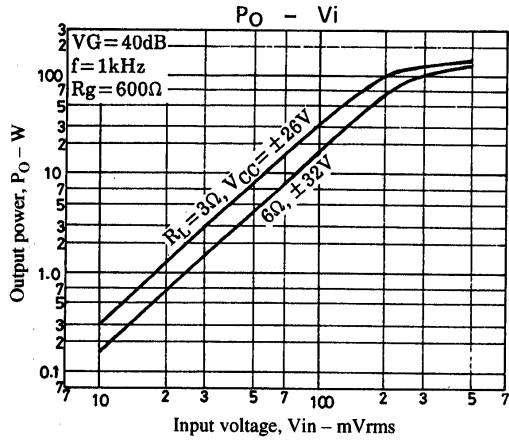

- No products described or contained herein are intended for use in surgical implants, life-support systems, aerospace equipment, nuclear power control systems, vehicles, disaster/crime-prevention equipment and the like, the failure of which may directly or indirectly cause injury, death or property loss.
- Anyone purchasing any products described or contained herein for an above-mentioned use shall:
 - ① Accept full responsibility and indemnify and defend SANYO ELECTRIC CO., LTD., its affiliates, subsidiaries and distributors and all their officers and employees, jointly and severally, against any and all claims and litigation and all damages, cost and expenses associated with such use:
 - ② Not impose any responsibility for any fault or negligence which may be cited in any such claim or litigation on SANYO ELECTRIC CO., LTD., its affiliates, subsidiaries and distributors or any of their officers and employees jointly or severally.
- Information (including circuit diagrams and circuit parameters) herein is for example only; it is not guaranteed for volume production. SANYO believes information herein is accurate and reliable, but no guarantees are made or implied regarding its use or any infringements of intellectual property rights or other rights of third parties.

This catalog provides information as of July, 1997. Specifications and information herein are subject to change without notice.