

Overview

The STK311-120 is an RDS demodulator hybrid IC for the Radio Data System (RDS), or multiplexed FM broadcasting of various kinds of data, introduced within the European Broadcasting Union (EBU). It demodulates the multiplexed data modulating signal to recover the RDS signal. In combination with an LC7070 series LSI (for sync handling, error detection and correction), a low-cost high-performance RDS data decode system can be constructed. Further, low-profile packaging is realized using Sanyo's insulated metal substrate technology (IMST) for the base, SC system and photoresist technologies and folded board construction.

Applications

- Car stereos
- Home stereos

Features

- Smaller width package dimension (35mm max.) than the STK311-110
- 57kHz BPF built-in for adjustment-free operation
- Few external components required for a complete RDS data demodulation system
- ARI-SK/DK decoder built-in

Package Dimensions

unit: mm

4156

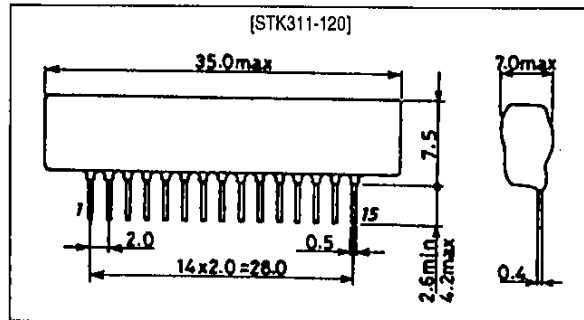

Specifications

Maximum Ratings at Ta = 25°C

Parameter	Symbol	Ratings	Unit
Maximum supply voltage	V _{CC max}	6.3	V
Operating temperature	T _{opr}	-30 to +85	°C
Storage temperature	T _{stg}	-40 to +100	°C

Recommended Operating Voltages at Ta = 25°C

Parameter	Symbol	Ratings	Unit
Supply voltage	V _{CC}	5	V
Operating supply voltage range	V _{CCOP}	4.7 to 5.5	V

Operating Characteristics at Ta = 25°C, V_{CC} = 5V

Parameter	Symbol	Conditions	min	typ	max	Unit
Quiescent current	I _{CCO}		-	22	30	mA
Band-pass filter gain	V _{G_{BPF}}	f = 57kHz	9	12.5	17	dB
Center frequency			55.8	57	58.2	kHz
Q			-	9	-	
Band-pass filter selectivity		f = 90kHz (57kHz = 0dB)	-50	-38	-20	dB
		f = 60kHz (57kHz = 0dB)	-4	-2.5	0	dB
		f = 54kHz (57kHz = 0dB)	-5	-3.5	0	dB
		f = 38kHz (57kHz = 0dB)	-50	-39	-35	dB
PLL capture range	CR	5mVrms, CW input	-	-0.5 +1.1	-	%
RDS detector sensitivity		Pin 10 low, input on pin 15	0.15	0.4	1.0	mVrms
SK detector sensitivity		Pin 11 low, input on pin 15	0.3	1.0	2.0	mVrms
DK detector sensitivity		Pin 12 low, input on pin 15	0.8	1.5	2.6	mVrms
RDS input dynamic range		Pin 10 low, (ARI + RDS) signal maximum input on pin 15	30	50	-	mVrms
DK input dynamic range		Pin 12 low, ARI signal maximum input on pin 15	75	100	-	mVrms
VCO free-running frequency	f _{osc}		453	456	459	kHz

Equivalent Circuit

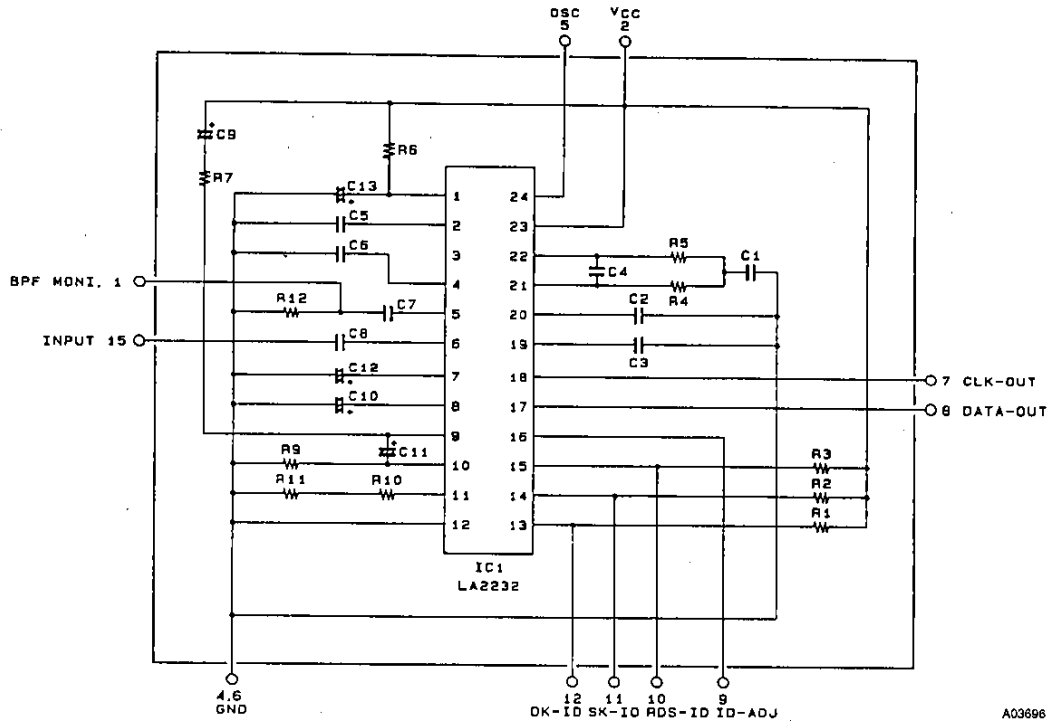

R11 is a function trimming resistor.
Pins 3, 13 and 14 are no connection pins.

A03696

Sample Application Circuit

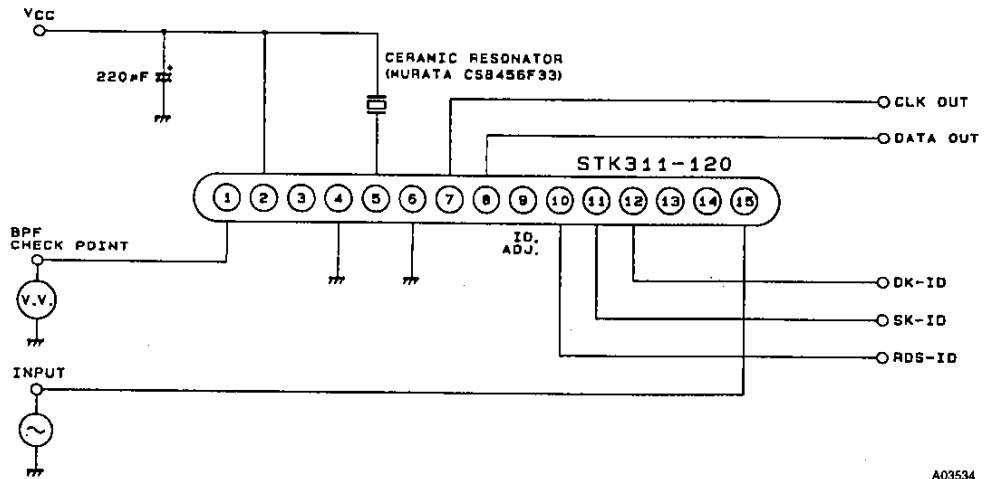

Pins 3, 13 and 14 are left open.

A03534

Sample System Configuration

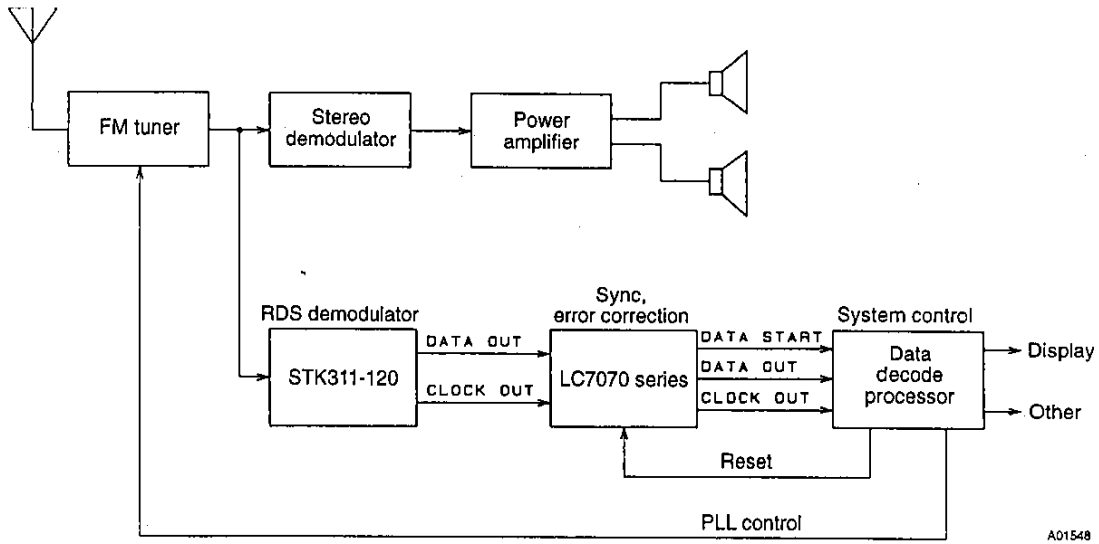

A01548

Pin Functions

Pin No.	Pin name	Function
1	MONI	BPF (for adjustment) monitor output
2	V _{CC}	Supply pin
4, 6	GND	Ground pins
5	OSC	VCO ceramic oscillator pin (456kHz)
7	CLK OUT	Clock output
8	DATA OUT	Data output
9	ID-ADJ	SK detector sensitivity adjustment pin
10	RDS-ID	RDS signal detector indicator output. Low-level output when an RDS signal is detected, and high-level when not detected.
11	SK-ID	SK signal detector indicator output. Low-level output when an SK signal is detected, and high-level when not detected.
12	DK-ID	DK signal detector indicator output. Low-level output when an DK signal is detected, and high-level when not detected.
15	INPUT	Input pin

Sample RDS Data Decoder Circuit

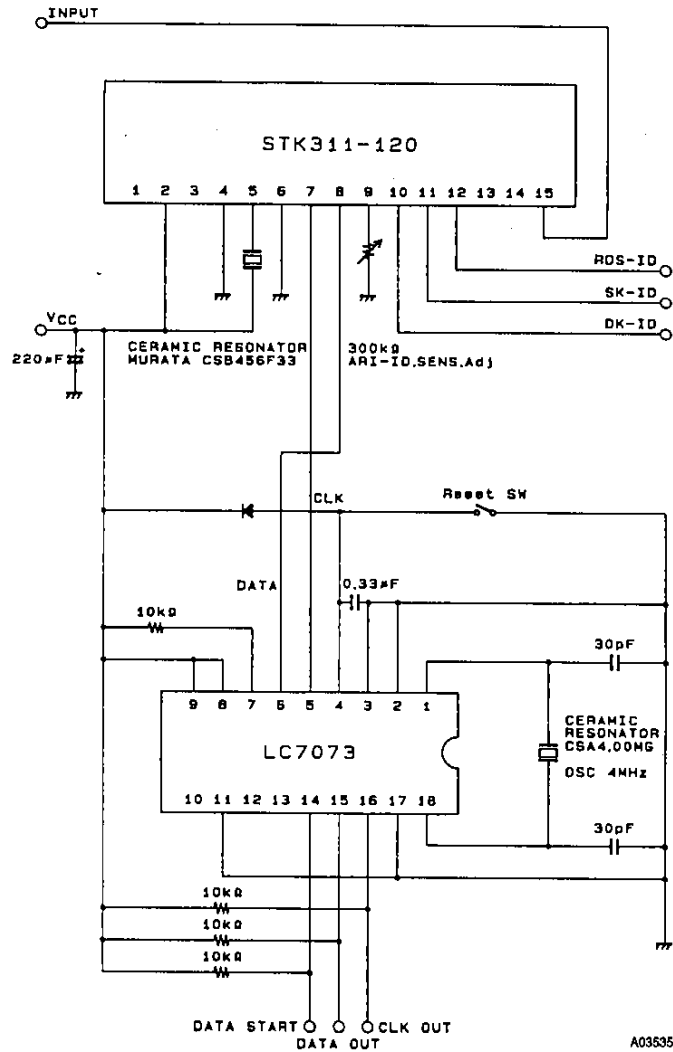

Characteristics Data

57kHz BPF selectivity

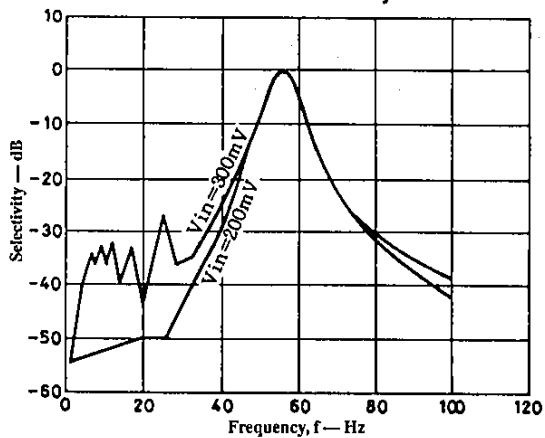

SK detector sensitivity adjustment

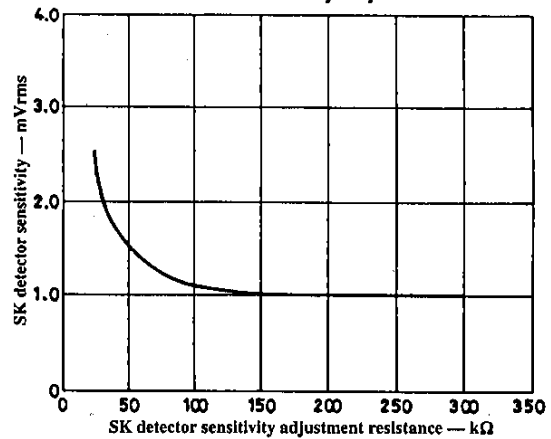

- No products described or contained herein are intended for use in surgical implants, life-support systems, aerospace equipment, nuclear power control systems, vehicles, disaster/crime-prevention equipment and the like, the failure of which may directly or indirectly cause injury, death or property loss.
- Anyone purchasing any products described or contained herein for an above-mentioned use shall:
 - ① Accept full responsibility and indemnify and defend SANYO ELECTRIC CO., LTD., its affiliates, subsidiaries and distributors and all their officers and employees, jointly and severally, against any and all claims and litigation and all damages, cost and expenses associated with such use:
 - ② Not impose any responsibility for any fault or negligence which may be cited in any such claim or litigation on SANYO ELECTRIC CO., LTD., its affiliates, subsidiaries and distributors or any of their officers and employees, jointly or severally.
- Information (including circuit diagrams and circuit parameters) herein is for example only; it is not guaranteed for volume production. SANYO believes information herein is accurate and reliable, but no guarantees are made or implied regarding its use or any infringements of intellectual property rights or other rights of third parties.

This catalog provides information as of June, 1995. Specifications and information herein are subject to change without notice.