

Preliminary

Overview

The STK311-050 is an RDS/RBDS demodulator hybrid IC for the Radio Data System (RDS) and the Radio Broadcast Data System (RBDS), or multiplexed FM broadcasting of various kinds of data, specified by the European Broadcasting Union (EBU) and US National Radio System Committee (NRSC), respectively. It demodulates the multiplexed data modulating signal to recover the RDS/RBDS signal and performs synchronization, error detection and error correction. Further, low-profile packaging is realized using Sanyo's insulated metal substrate technology (IMST) for the base, SC system and photore-sist technologies and folded board construction.

Applications

- Car stereos
- Home stereos

Features

- 57kHz BPF built-in for adjustment-free operation
- 4MHz ceramic oscillator element built-in
- Few external components required for a complete RDS/RBDS data demodulation system
- ARI-SK/DK decoder built-in

Specifications

Maximum Ratings at $T_a = 25^\circ\text{C}$

Parameter	Symbol	Rating	Unit
Maximum supply voltage	$V_{CC \text{ max}}$	6.3	V
Operating temperature	T_{opr}	-30 to +85	$^\circ\text{C}$
Storage temperature	T_{stg}	-40 to +100	$^\circ\text{C}$

Recommended Operating Voltages at $T_a = 25^\circ\text{C}$

Parameter	Symbol	Rating	Unit
Supply voltage	V_{CC}	5	V
Operating supply voltage range	V_{CCOP}	4.7 to 5.5	V

Package Dimensions

unit: mm

4132A

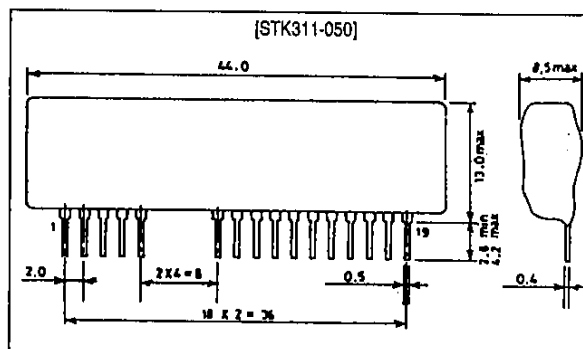

Operating Characteristics at Ta = 25°C, VCC = 5V

Parameter	Symbol	Conditions	min	typ	max	Unit
Quiescent current	I _{CCO}		-	26	38	mA
Band-pass filter gain	V _{G_{BPF}}	f = 57kHz	9	12.5	17	dB
Band-pass filter selectivity		f = 60kHz (57kHz = 0dB)	-6	-2.5	0	dB
		f = 54kHz (57kHz = 0dB)	-6	-3.5	0	dB
		f = 38kHz (57kHz = 0dB)	-	-39	-33	dB
PLL capture range	CR	5mVrms, CW input	-	-0.5 +1.1	-	%
RDS/RBDS detector sensitivity		Pin 12 low, input on pin 4	-	0.4	1.0	mVrms
SK detector sensitivity		Pin 11 low, input on pin 4	-	1.0	2.0	mVrms
DK detector sensitivity		Pin 10 low, input on pin 4	-	1.9	2.9	mVrms
RDS/RBDS input dynamic range		Pin 12 low, (ARI+RDS/RBDS) signal maximum input on pin 4	30	50	-	mVrms
		RDS/RBDS data demodulated correctly, RDS/RBDS signal maximum input on pin 4	250	-	-	mVrms
DK input dynamic range		Pin 10 low, ARI signal maximum input on pin 4	75	100	-	mVrms
VCO free-running frequency	f _{OSC}		453	456	459	kHz
High level output voltage	V _{OH}	I _{OH} = -50μA ^{*1}	V _{CC} - 1.2	-	-	V
		I _{OH} = -10μA ^{*1}	V _{CC} - 0.5	-	-	V
Low level output voltage	V _{OL}	I _{OL} = 10mA ^{*2}	-	-	1.5	V
		I _{OL} = 1.8mA ^{*2}	-	-	0.4	V
Ceramic oscillator stabilization time	t _{CFS}	See Figure 1.	-	-	10	ms
Reset time	t _{RST}		See Figure 2.			

- *1. DATA START, DATA OUT, CLOCK OUT
- *2. RECEIVE, CORRECTION, ERROR, DATA START, DATA OUT, CLOCK OUT

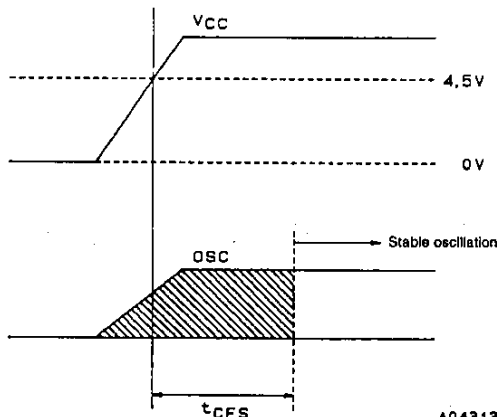

Figure 1. Oscillator stabilization time

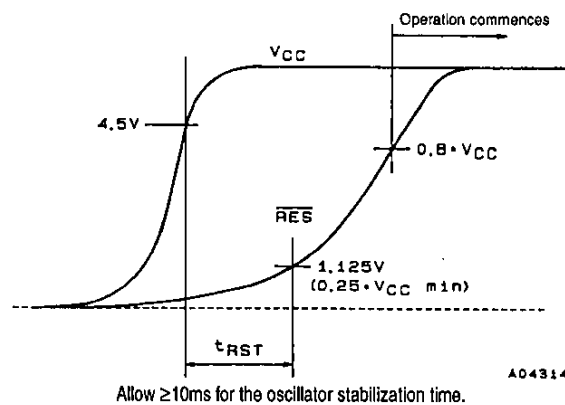

Figure 2. Reset time

Output Signal Settings

CLK OUT and DATA START output signals can be set as shown in the following table.

Setting ^{*1}	CLK OUT polarity	DATA START output
1	Falling edge	Each block
2	Falling edge	Second block only
3	Rising edge	Each block
4	Rising edge	Second block only

*1. Setting 1 is the default setting.

Equivalent Circuit

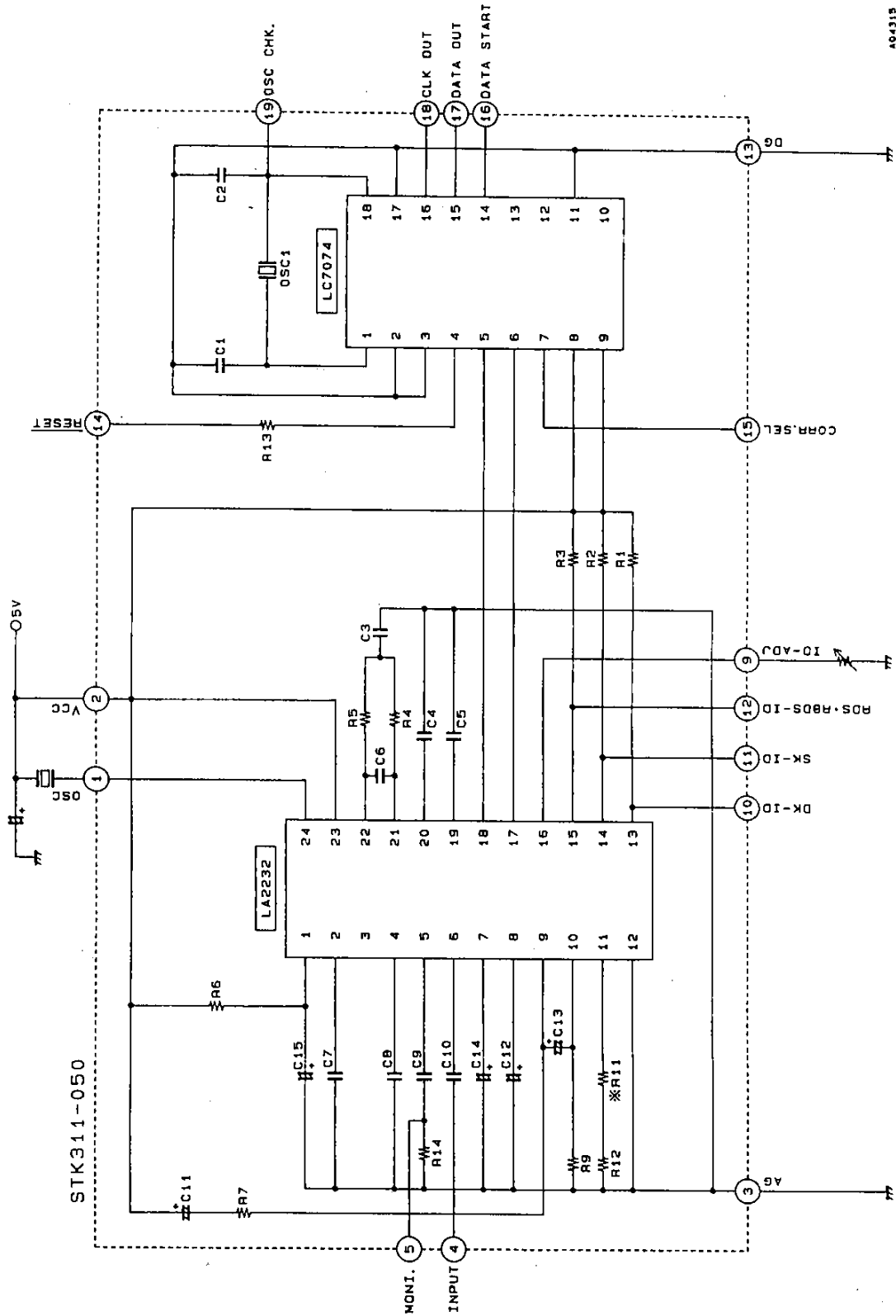

A04315

* R11 is a function trimming resistor.
Pins 6, 7 and 8 are not used.

Sample Application Circuit

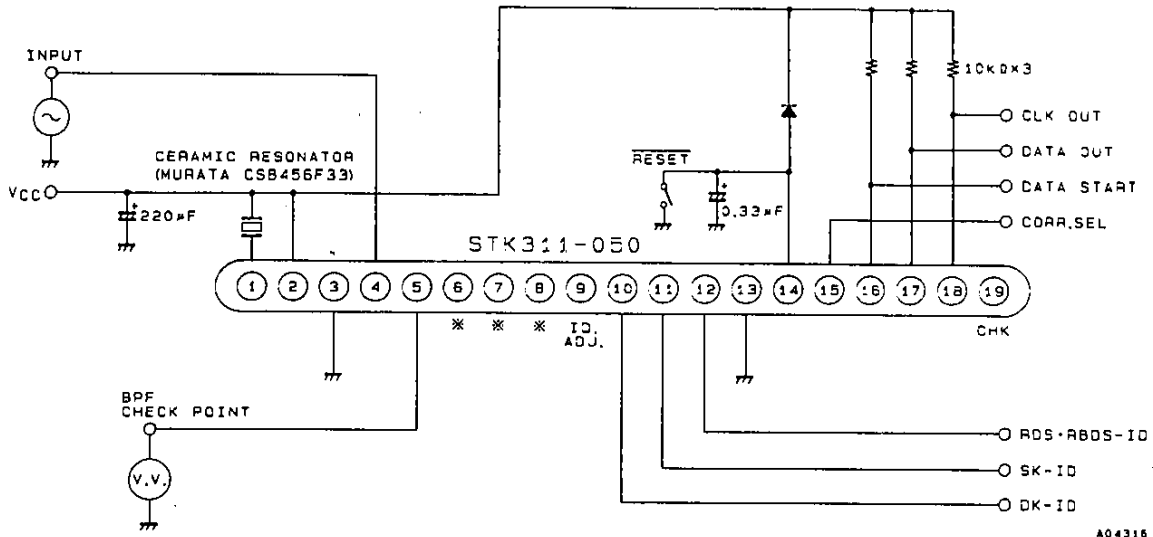

* Pins 6, 7 and 8 are not used.

A04316

Sample System Configuration

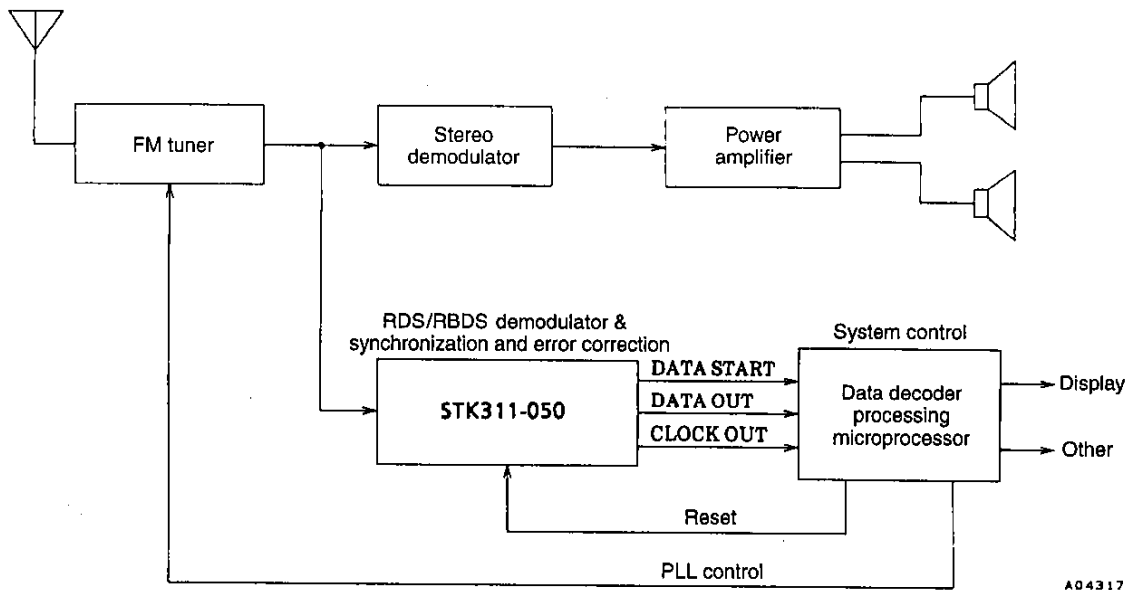

A04317

Pin Functions

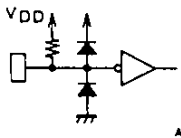
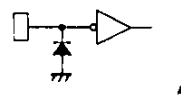
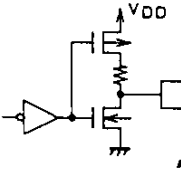
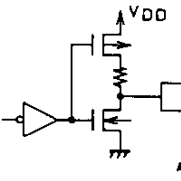
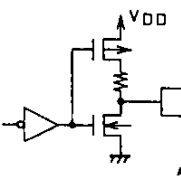
Pin No.	Pin name	Function
1	OSC	VCO ceramic oscillator pin (456kHz)
2	V _{CC}	Supply pin: LA2232 and LC7074 positive supply
3	AG	Ground pin: LA2232 analog ground
4	INPUT	Input pin
5	MONI	BPF (for adjustment) monitor output
9	ID-ADJ	SK detector sensitivity adjustment pin
10	DK-ID	DK signal detector indicator output. Low-level output when an DK signal is detected, and high-level when not detected.
11	SK-ID	SK signal detector indicator output. Low-level output when an SK signal is detected, and high-level when not detected.
12	RDS/RBDS-ID	RDS/RBDS signal detector indicator output. Low-level output when an RDS/RBDS signal is detected, and high-level when not detected.
13	DG	Ground pin: LC7074 digital ground
14	RESET	 <p>Reset input. Reset restart occurs when held low for ≥ 4 cycles. Schmitt-trigger input. Pull-up resistor built-in.</p> <p style="text-align: right;">A04318</p>
15	CORR. SEL.	 <p>Error correction selection input. This pin selects whether the IC corrects errors in the RDS demodulated data. Input = 0: No correction performed. Input = 1: Error correction performed. In modes where error correction is enabled, up to five error bits are corrected for distances of 5 bits or less.</p> <p style="text-align: right;">A04319</p>
16	DATA START	 <p>Serial data output block data start signal (D.S. CONTROL) input to control the output waveform. Pull-up MOS transistor (CMOS) output.</p> <p style="text-align: right;">A04320</p>
17	DATA OUT	 <p>Serial data output. Pull-up MOS transistor (CMOS) output.</p> <p style="text-align: right;">A04320</p>
18	CLK OUT	 <p>Clock output. Pull-up MOS transistor (CMOS) output.</p> <p style="text-align: right;">A04320</p>
19	OSC CHK	OSC1 oscillation frequency check pin

RDS/RBDS Demodulator Data (LA2232 Output) and LC7074 Output Data Relationship

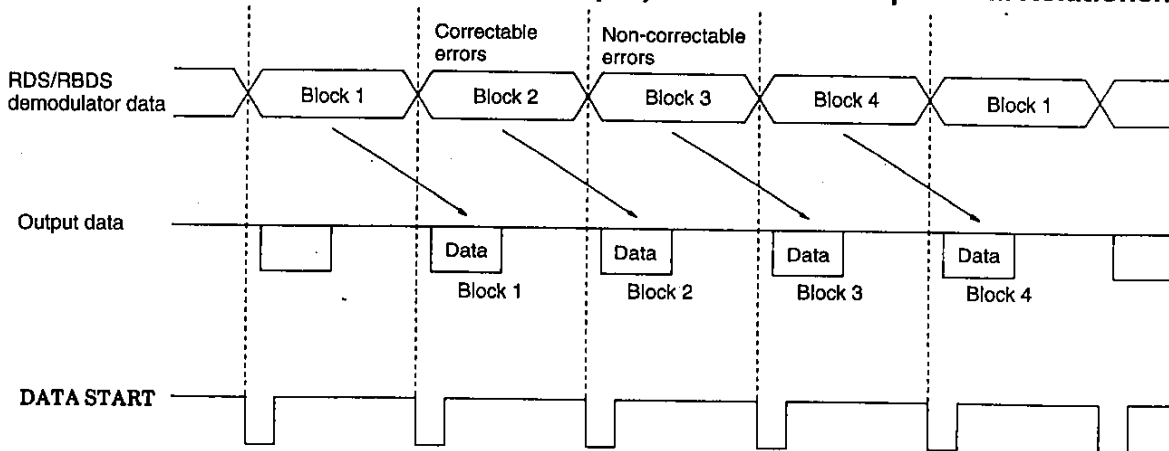

The LC7074 serial data output is delayed by 1 block from the data received from the LA2232.

A04321

Figure 3. Demodulator data and output data relationship

Serial Data Output Format and Timing

Bit	Function													
S	Start bit (normally "0")													
E	Error flag	<table border="1"> <thead> <tr> <th>Parameter</th> <th>E</th> <th>F</th> </tr> </thead> <tbody> <tr> <td>No errors</td> <td>0</td> <td>0</td> </tr> <tr> <td>Errors corrected</td> <td>0</td> <td>1</td> </tr> <tr> <td>Non-correctable errors</td> <td>1</td> <td>1</td> </tr> </tbody> </table>	Parameter	E	F	No errors	0	0	Errors corrected	0	1	Non-correctable errors	1	1
		Parameter	E	F										
No errors	0	0												
Errors corrected	0	1												
Non-correctable errors	1	1												
F	Correction flag	Note: When CORR. SEL is high.												
OE	Offset E													
OF	Offset F (normally "0", for future expansion)													
A/B	Group type version	0: Version A 1: Version B												
B1, B0	Block number	00: Block 1 01: Block 2 10: Block 3 11: Block 4												
D15 to D0	RDS/RBDS data													

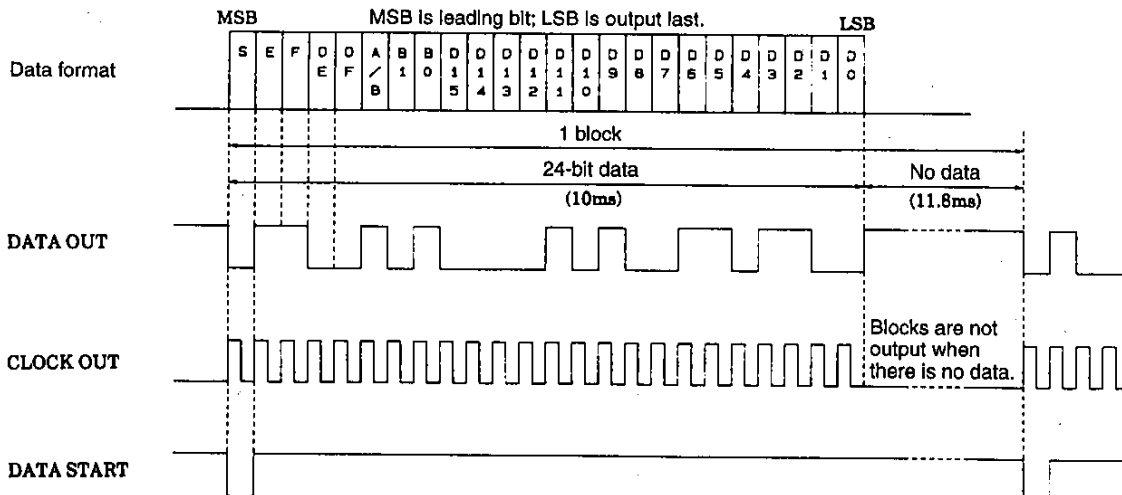

Figure 4. Serial data output format and timing

A04322

Control Input CORR. SEL Read Timing

Normally, this pin is checked for its state. However, error correction can be enabled/disabled at any time.

During Sync Detection

CORR. SEL is read for every bit of demodulator data from the RDS/RBDS demodulator IC (indicated by ↓), and is read into the LSI when 4 consecutive, matching states occur.

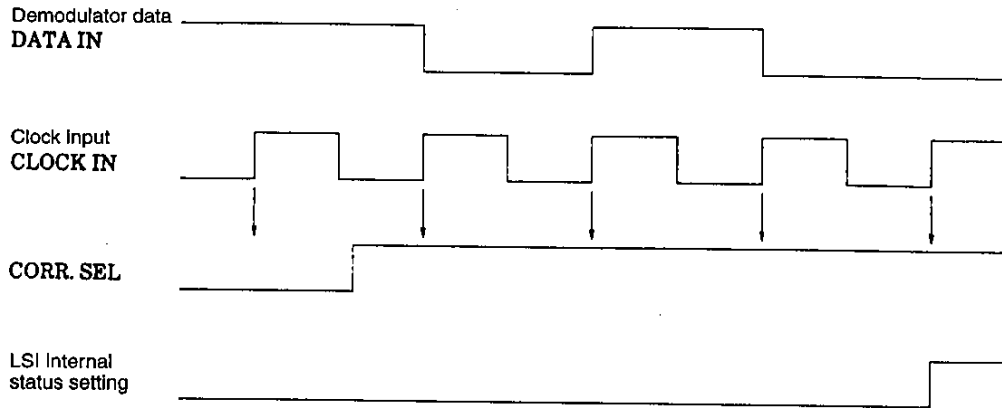

A04323

Figure 5. CORR.SEL read timing during sync detection

After Sync Detection

CORR. SEL is read for the head of each block of demodulator data from the RDS/RBDS demodulator IC (indicated by ↓), and is read into the LSI when 4 consecutive, matching states occur.

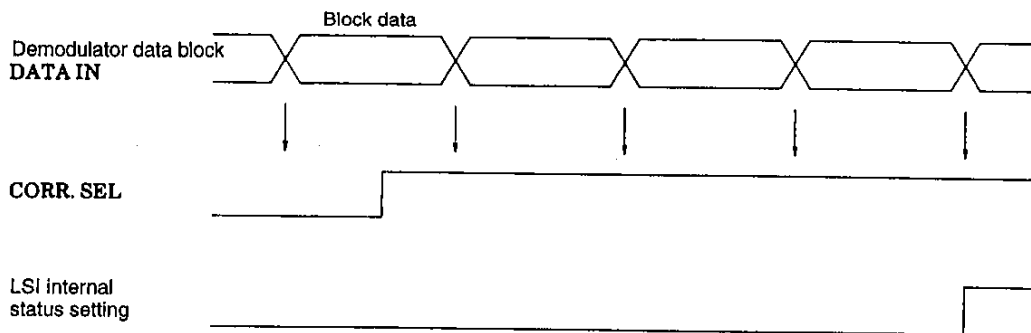

A04324

Figure 6. CORR.SEL read timing after sync detection

Characteristics Data

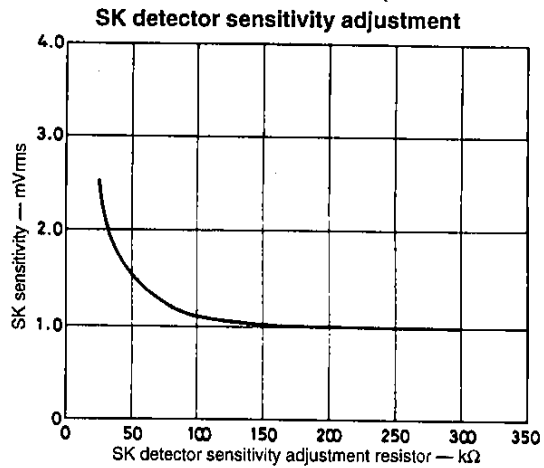
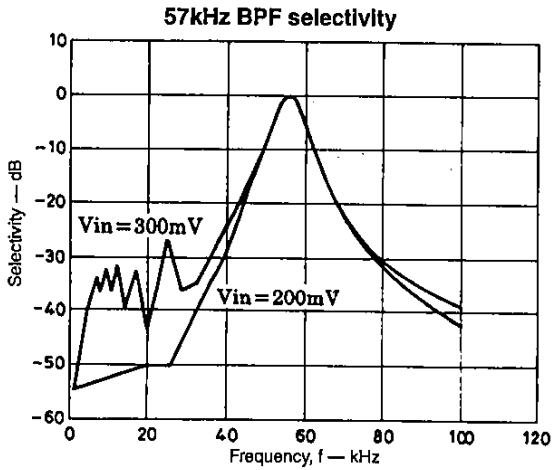

- No products described or contained herein are intended for use in surgical implants, life-support systems, aerospace equipment, nuclear power control systems, vehicles, disaster/crime-prevention equipment and the like, the failure of which may directly or indirectly cause injury, death or property loss.
- Anyone purchasing any products described or contained herein for an above-mentioned use shall:
 - ① Accept full responsibility and indemnify and defend SANYO ELECTRIC CO., LTD., its affiliates, subsidiaries and distributors and all their officers and employees, jointly and severally, against any and all claims and litigation and all damages, cost and expenses associated with such use:
 - ② Not impose any responsibility for any fault or negligence which may be cited in any such claim or litigation on SANYO ELECTRIC CO., LTD., its affiliates, subsidiaries and distributors or any of their officers and employees, jointly or severally.
- Information (including circuit diagrams and circuit parameters) herein is for example only; it is not guaranteed for volume production. SANYO believes information herein is accurate and reliable, but no guarantees are made or implied regarding its use or any infringements of intellectual property rights or other rights of third parties.

This catalog provides information as of January, 1996. Specifications and information herein are subject to change without notice.