

Description

The S3001 is a monolithic integrated circuit, and suitable for 5-ch motor driver which driver focus actuator, tracking actuator, sled motor, spindle motor and tray motor of CDP & V-CD system.

Features

- 1ch(forward-reverse) control DC motor driver
- 4ch BTL(Balanced Transformerless) driver
- Built-in TSD (Thermal shutdown) circuit
- Built-in 5V regulator with an internal NPN TR
- Built-in mute circuit
- Built-in Tray motor speed control circuit
- Wide operating supply voltage range: 6.5V~13.2V

Ordering Information

Type NO.	Marking	Package Code
S3001	S3001	28-SSOPH

BLOCK DIAGRAM

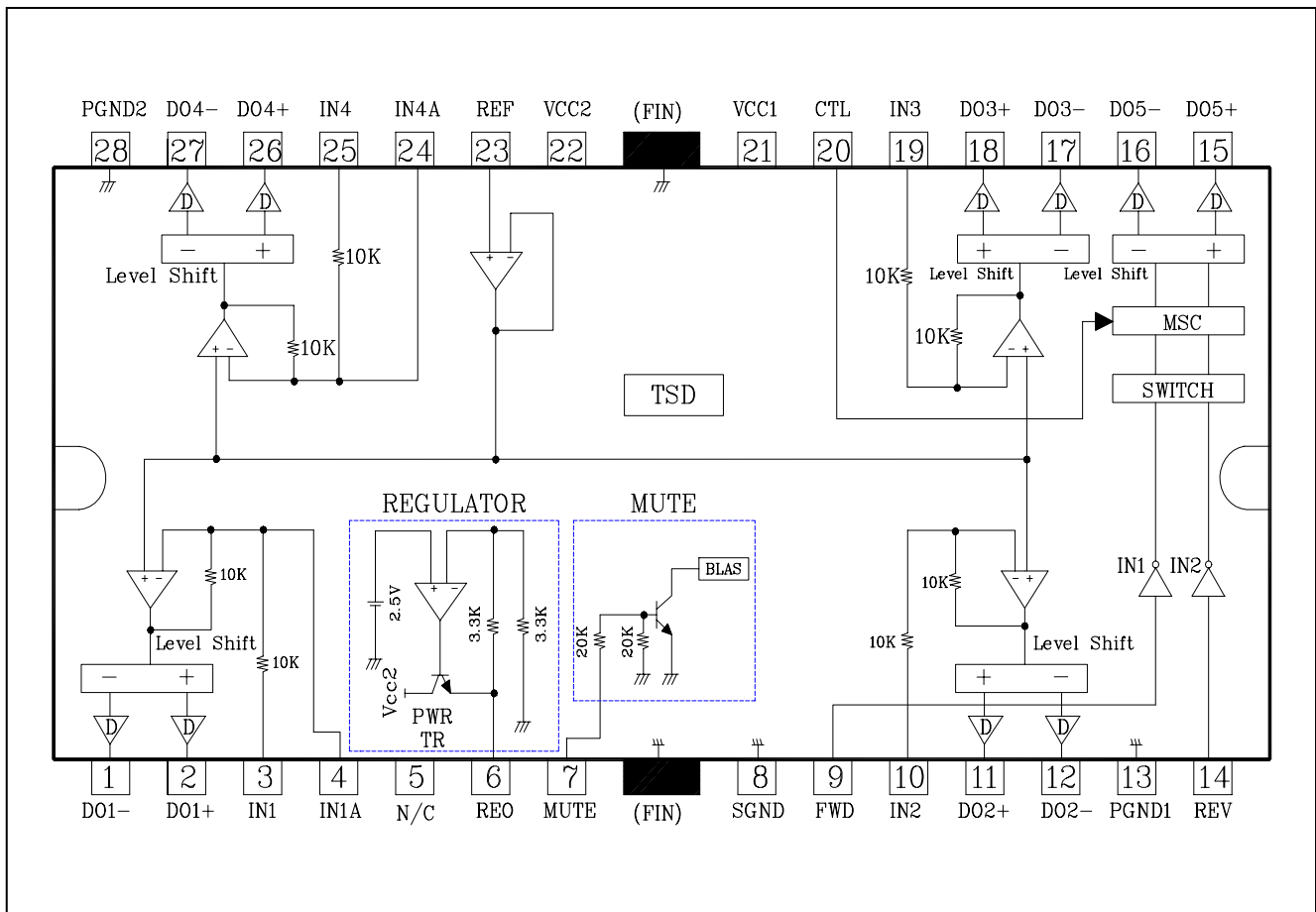

PIN CONNECTIONS

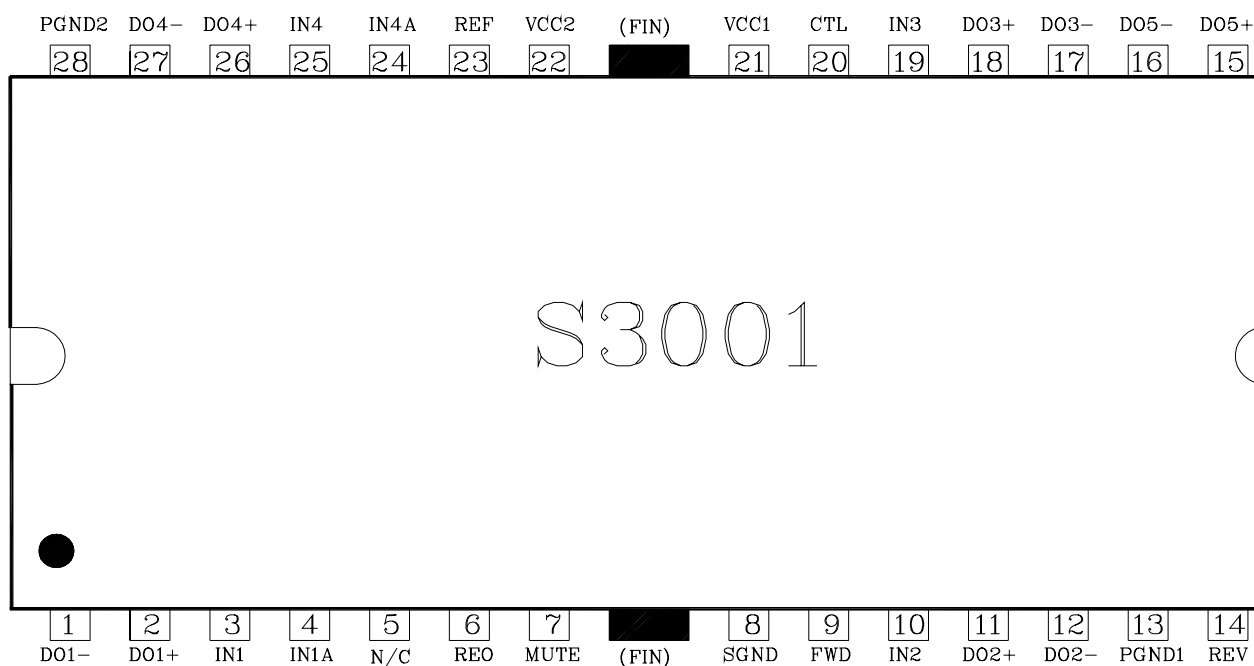

PIN DESCRIPTIONS

NO	SYMBOL	I/O	DESCRIPTION	NO	SYMBOL	I/O	DESCRIPTION
1	DO1-	O	CH1 OUTPUT (-)	15	DO5+	O	CH5 OUTPUT (+)
2	DO1+	O	CH1 OUTPUT(+)	16	DO5-	O	CH5 OUTPUT (-)
3	IN1	I	CH1 INPUT 1	17	DO3-	O	CH3 OUTPUT (-)
4	IN1A	I	CH1 INPUT 2	18	DO3+	O	CH3 OUTPUT (+)
5	N / C	-	NO-CONNECTION	19	IN3	I	CH3 INPUT
6	REO	O	REGULATOR OUTPUT	20	CTL	I	CH5 MOTOR SPEED CONTROL
7	MUTE	I	MUTE INPUT	21	VCC1	I	SUPPLY VOLTAGE 1 (CH2,CH3,CH5)
8	SGND	-	SIGNAL GROUND	22	VCC2	I	SUPPLY VOLTAGE 2 (CH1,CH4,SIGNAL,REG)
9	FWD	I	CH5 INPUT 1	23	REF	I	CH BIAS INPUT
10	IN2	I	CH2 INPUT	24	IN4A	I	CH4 INPUT 1
11	DO2+	O	CH2 OUTPUT (+)	25	IN4	I	CH4 INPUT 2
12	DO2-	O	CH2 OUTPUT (-)	26	DO4+	O	CH4 OUTPUT (+)
13	PGND1	-	POWER GROUND 1	27	DO4-	O	CH4 OUTPUT (-)
14	REV	I	CH5 INPUT 2	28	PGND2	-	POWER GROUND 2

ABSOLUTE MAXIMUM RATINGS

CHARACTERISTICS	SYMBOL	VALUE	UNIT
Maximum supply voltage	Vccmax	15	V
Power dissipation	Pd	2.3 ^(Note)	W
Operating temperature	Topr	-35 ~ +85	
Storage temperature	Tstg	-55 ~ +150	
Maximum output current	Iomax	1	A

Note>

1. When mounted on 50mm × 50mm × 1mm PCB (Phenolic resin material).
2. Power dissipation reduces 18.4 mW/°C for using above Ta=25
3. Do not exceed Pd and SOA.

POWER DISSIPATION CURVE

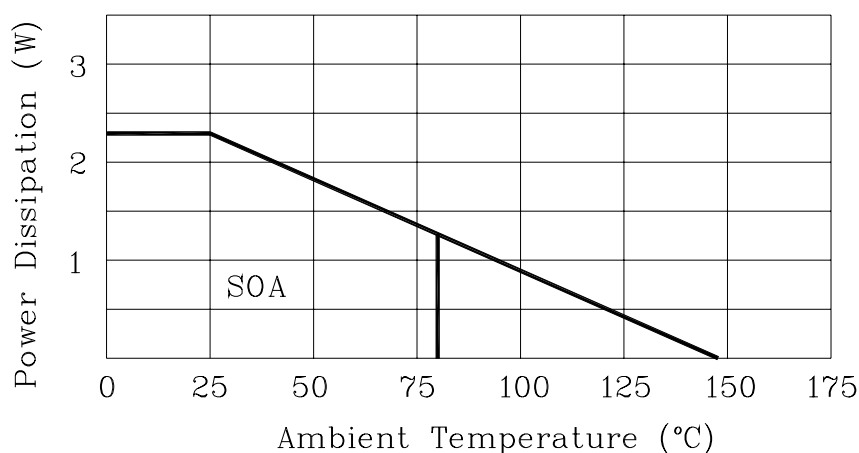

PRECOMMENDED OPERATING CONDITIONS

CHARACTERISTICS	SYMBOL	VALUE	UNIT
Supply voltage 1	Vcc1	6.5~13.2	V
Supply voltage 2	Vcc2	6.5~13.2	V

Electrical Characteristics

($T_a=25^{\circ}\text{C}$, $V_{CC1}=V_{CC2}=8\text{V}$, $R_L=8\text{ohm}$, unless otherwise specified.)

Characteristic	Symbol	Test Condition	Min.	Typ.	Max.	Unit
Quiescent circuit current	I_{CC}	-	-	10	-	mA
Mute on current	I_{mute}	Pin7=GND	-	2.5	5	mA
Mute on voltage	V_{mon}	-	-	-	0.5	V
Mute off voltage	V_{moff}	-	2	-	-	V
[BTL DRIVE PART]						
Output offset voltage	V_{oo}	$V_{in}=2.5\text{V}$	-40	-	+40	mV
Maximum output voltage	V_{om}	$V_{CC1}=V_{CC2}=8\text{V}$, 8ohm	4	5	-	V
Closed-loop voltage gain	A_{vf}	$V_{in}=0.1\text{Vrms}$, $f=1\text{KHz}$	5	6.5	8	dB
Ripple rejection ratio	RR	$V_{in}=0.1\text{Vrms}$, $f=120\text{Hz}$	50	60	-	dB
Slew rate	SR	$V_{out}=4\text{Vp-p}$, square	-	1.5	-	V/us
[REGULATOR PART]						
Output voltage	V_{reg}	$I_L=100\text{mA}$	4.7	5	5.3	V
Load regulation 1	V_{rl1}	$I_L=0\sim 100\text{mA}$	-40	-	10	mV
Load regulation 2	V_{rl2}	$I_L=0\sim 200\text{mA}$	-70	-	10	mV
Line regulation	V_{CC}	$V_{CC}=6.5\text{V}\sim 12.5\text{V}$, $I_L=100\text{mA}$	-20	-	+60	mV
[TRAY DRIVE PART]						
Input high level voltage	V_{ih}	-	2	-	-	V
Input low level voltage	V_{il}	-	-	-	0.5	V
Output voltage	V_o	$V_{CC}=8\text{V}$, $R_L=45\text{ohm}$, Pin20=open	2.5	3.1	3.8	V
Output voltage regulation	V_o	$V_{CC}=8\text{V}$, $R_L=45\text{ohm}$ Pin=20=3.5V ~ 4.5V	0.6	1	1.4	V
Output offset voltage 1	V_{oo1}	Pin9, Pin14=5V	-40	-	+40	mV
Output offset voltage 2	V_{oo2}	Pin9, Pin14=0V	-40	-	+40	mV

APPLICATION SUMMARY

- Reference & all mute

When you want to control output bias current of the S3001, use pin #23 as follows

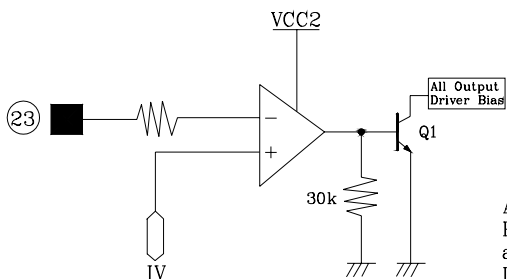

Fig1.Reference & all mute function

Pin#23	Mute
Above 1.0V	off
Below 1.0V	on

As shown in figure 1, Pin#23 is a negative input of the comparator, and the other input is the 1.0V reference. If the voltage of the Pin#23 falls below 1.0V, TR Q1 will be turned on and the output bias current will be shut down

- Mute

When you want to control output bias current of the S3001, you can also use pin#7 as follows

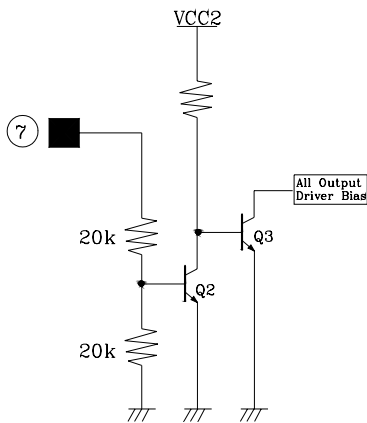

Fig2. Mute function

Pin#7	Mute
High	off
Low	on

As shown in figure 2, Pin#7 is a base input of the TR Q2. If the voltage of the pin#7 is low or open, TR Q2 will be turned off and TR Q3 will be turned on, so the bias current will be shut down by TR Q3. If the voltage of the pin#7 is high, the bias circuit operates normally.

APPLICATION SUMMARY(Continued)

- Thermal Shutdown

The S3001 has a thermal protection against the abnormal operation, and the detailed operation of the TSD circuit is as follows

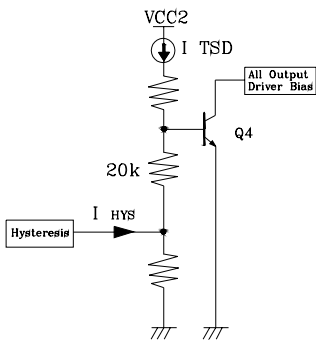

Fig3.Thermal shut down

Temperature	Mute
Above 175 °C	on
Falls below 150°C	off

As shown in figure 3, TSD circuit controls the base of the TR Q4. If the junction temperature rises above 175°C TR Q4 will be turned on, and the bias current of the output drive circuit will be shut down (because of the negative temperature characteristic of the NPN transistor). And then temperature falls below 150°C, TR Q4 will be turned off. (hysteresis temperature is about to 25°C)

- BTL drive part (Focus, Tracking, Spindle, Sled drive park)

BTL drive part is composed of V-I converter, level shifter and output power amp.

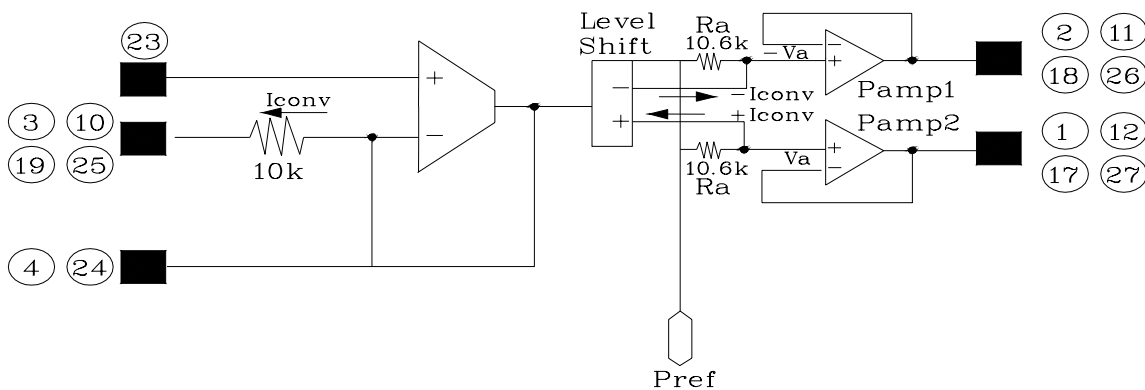

Fig4. BTL drive part

-V-I converter converts voltage of the input pin into current

$$I_{conv} = \frac{V_{in} - V_{ref}}{10k}$$

*Vin=input voltage of the input pin (pin3,10,19,25)

*Vref=reference voltage (pin23)

The level shift changes the direction of the current(I_{conv}) as the same amount, and then supply it to the power AMP.

The resistor $R_a(10.6K)$ converts current into voltage with the DC offset of P_{ref} .

$$V_a = 10.6K \times \frac{V_{in} - V_{ref}}{10k} + P_{ref}$$
$$-V_a = -10.6K \times \frac{V_{in} - V_{ref}}{10k} + P_{ref} \quad \text{When } P_{ref} = \frac{V_{CC1} - V_{be}}{2}$$

The power amp has unity gain.

So the total differential voltage gain of the S3001 is as follows.

$$\text{Gain} = 20 \log \frac{\{[10.6k \times \frac{V_{in} - V_{ref}}{10k} + P_{ref}] - [(-)10.6k \times \frac{V_{in} - V_{ref}}{10k} + P_{ref}]\}}{V_{in} - V_{ref}}$$
$$= 20 \log 2 \times \frac{10.6K}{10K}$$
$$= 6.527 \text{dB}$$

If you want to reduce the total gain of the BTL drive part, use additional series resistor into the input pin(pin#3, 10, 19, 25)

You can also increase or decrease the voltage gain of the CH1, CH4 using adjustable pin(pin#4, pin24) by inserting an external series resistor.

APPLICATION SUMMARY(Continued)

- Tray motor drive part

CH5 is a forward-reverse control DC motor driver and it is composed of logic control part, level shifter, and output power

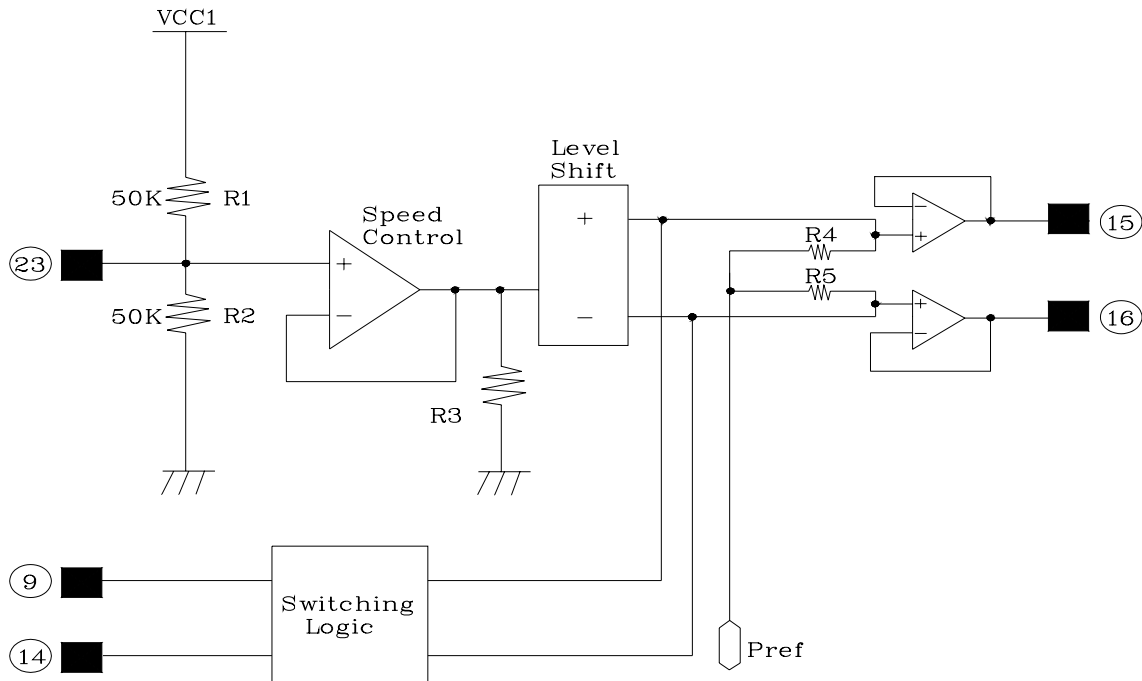

Fig5. Tray drive part

The forward and reverse rotation is controlled by pin9(fwd), pin14(rev) and the amplitude of the output voltage is controlled by pin20(CTL).

The output status due to the input conditions are as follows

INPUT		OUTPUT		
FWD(PIN9)	REV(PIN14)	DO5+(PIN15)	DO5-(PIN16)	STATUS
High	High	Vp	Vp	Brake
High	Low	High	Low	Forward
Low	High	Low	High	Reverse
Low	Low	Vp	Vp	Brake

APPLICATION SUMMARY(Continued)

- Tray motor speed control

The amplitude of the output voltage is controlled by pin20(CTL).

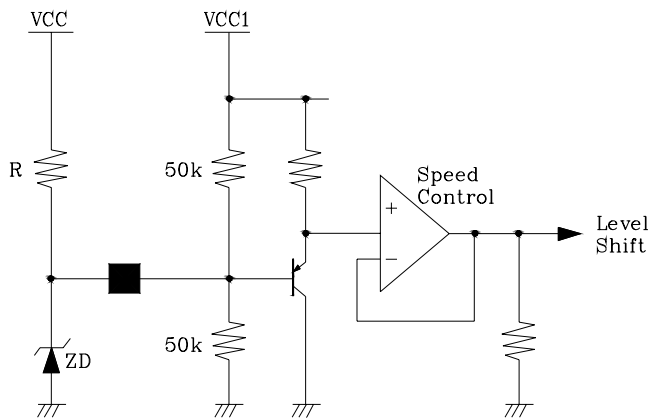

Fig6.Thay motor speed control

Normally, the differential output voltage is 3.1V when the pin20(CTL) is open.

If you want to control differential output voltage of the tray drive part, insert external resistor R and zener diode ZD as shown in figure 6.

Zener diode ZD is only needed when you want to obtain a precision output voltage, In other case you only insert an external resistor R.

- Regulator part

S3001 has a temperature independent voltage source internally.

So in the figure 7, the reference voltage (2.5V) is generated by the internal circuit (bandgab reference),

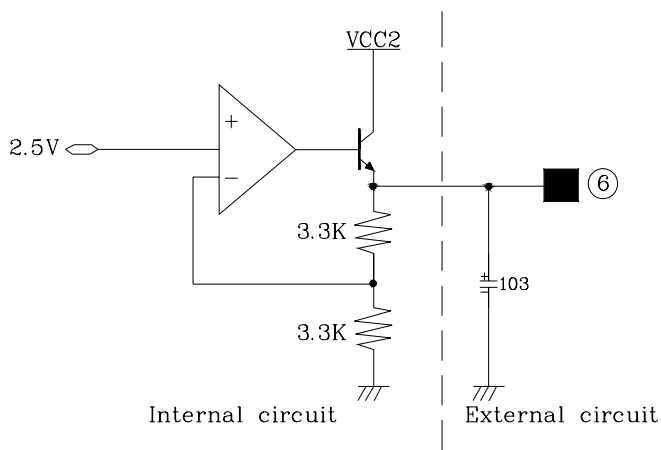

Fig7. Regulator

Because the power NPN TR Q5 is inserted internally, there is no need to attach an external active component.

The output voltage of the regulator is Calculated as follows

$$V_{re0} = (1 + \frac{3.3K}{3.3K}) \times 2.5 = 5V$$

And he capacitor 1uF is used as a ripple & noise eliminator and should have a good Temperature characteristics.

TEST CIRCUIT

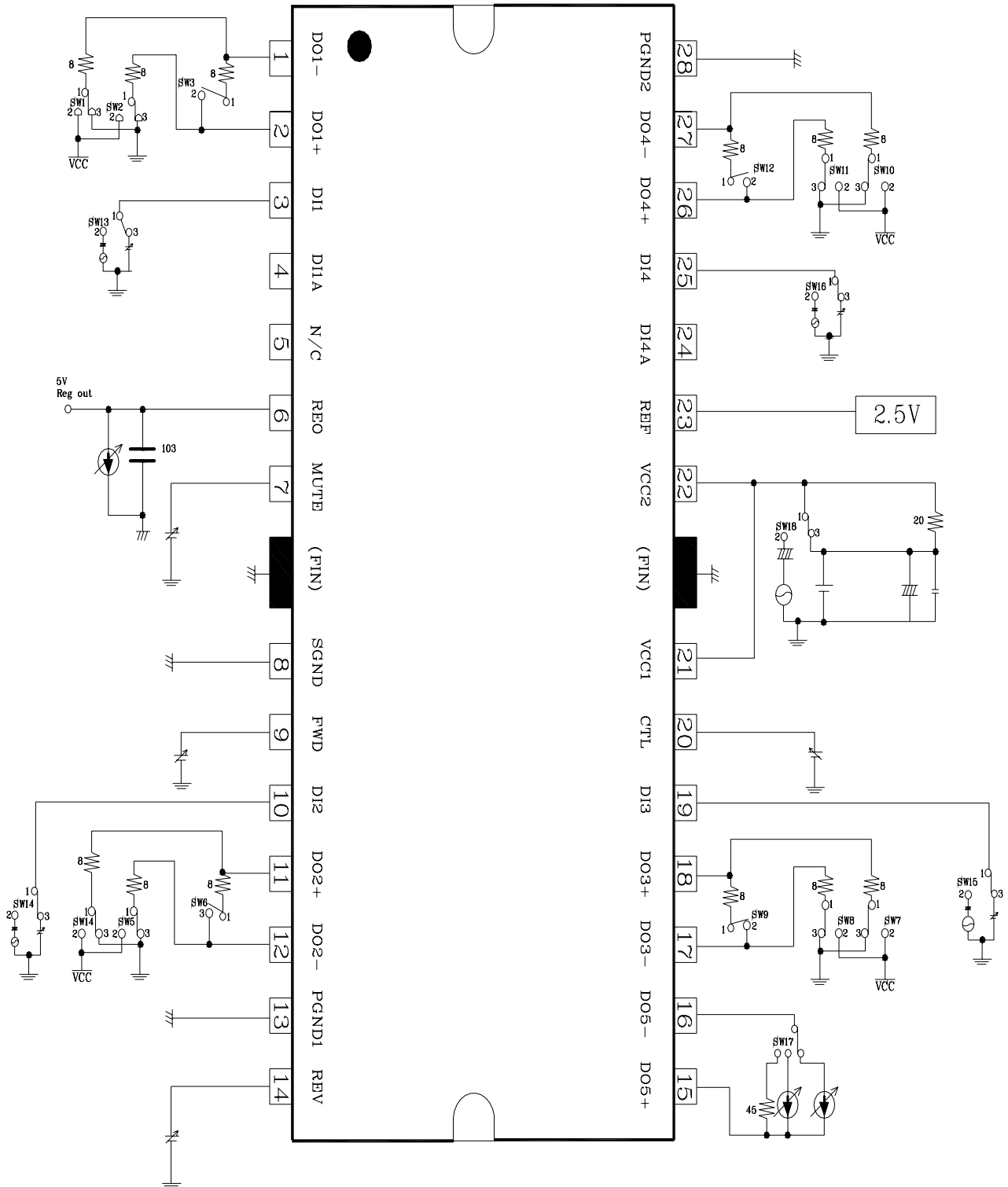

TYPICAL APPLICATION CIRCUIT

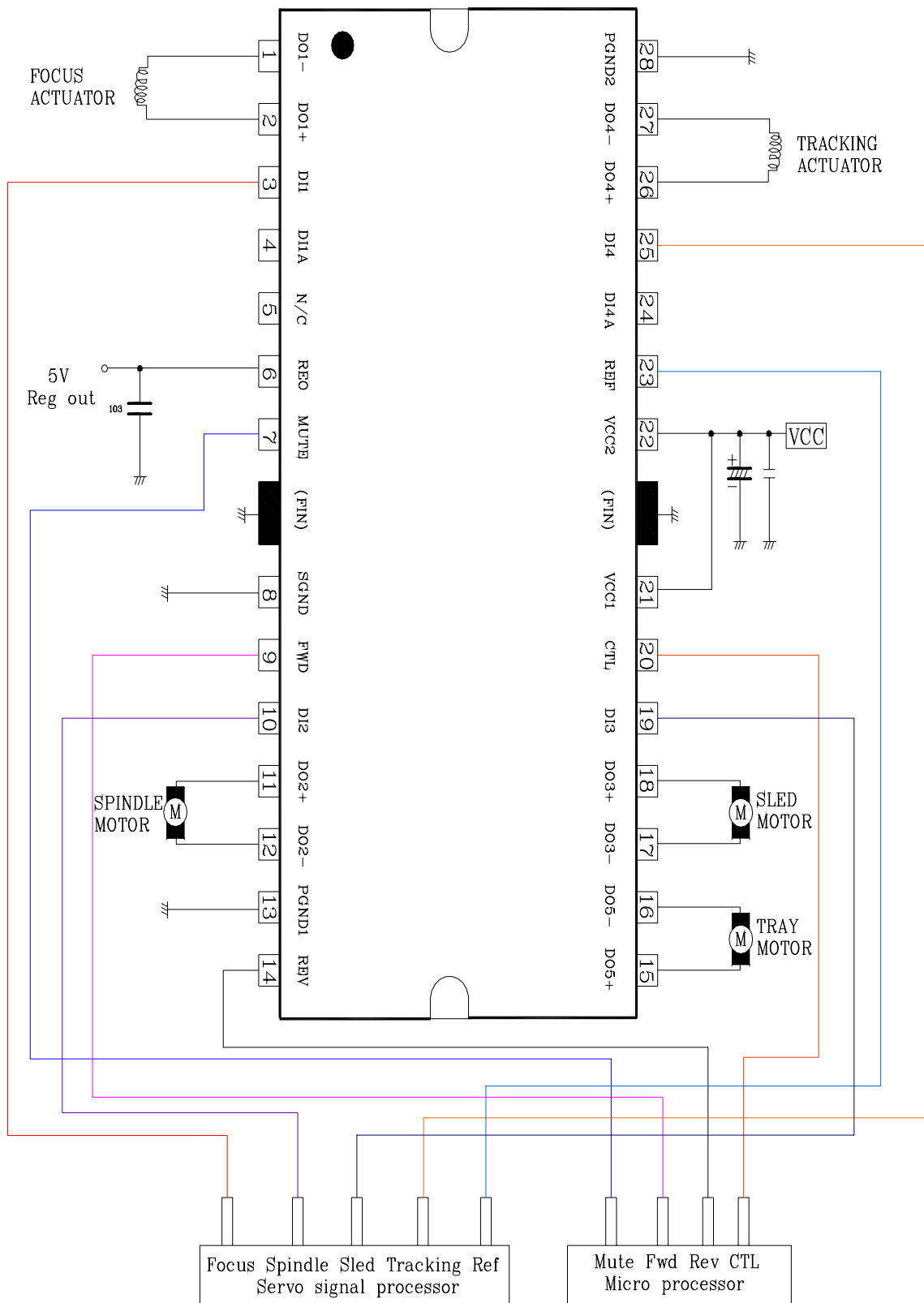

INTERNAL CIRCUIT

Pin no	Pin name	Internal circuit
<p>1,2, 11,12, 15,16 17,18 26,27</p>	<p>DO1- DO1+ DO2+ DO2- DO5+ DO5- DO3- DO3+ DO5+ DO5-</p>	
<p>3, 4, 10, 19, 23, 24, 25,</p>	<p>IN1 IN1A IN2 IN3 REF IN4A IN4</p>	

INTERNAL CIRCUIT(Continued)

Pin no	Pin name	Internal circuit
6	REO	
7	MUTE	
9,14	FWD REV	

INTERNAL CIRCUIT(Continued)

Pin no	Pin name	Internal circuit
20	CTL	

Electrical Characteristic Curves

Fig. 1. VCC vs ICC

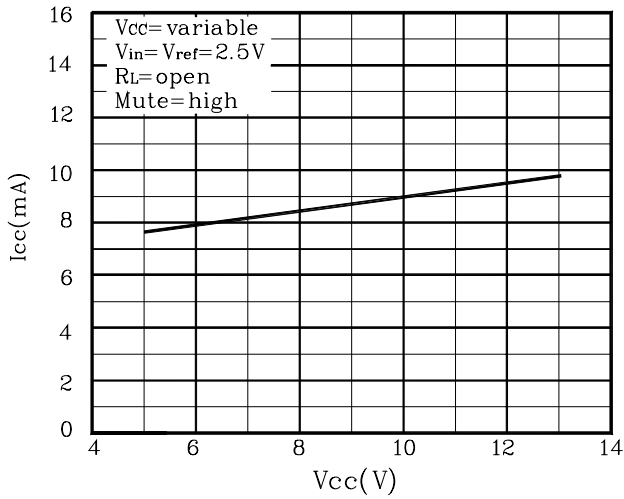

Fig. 2. VCC vs Imute

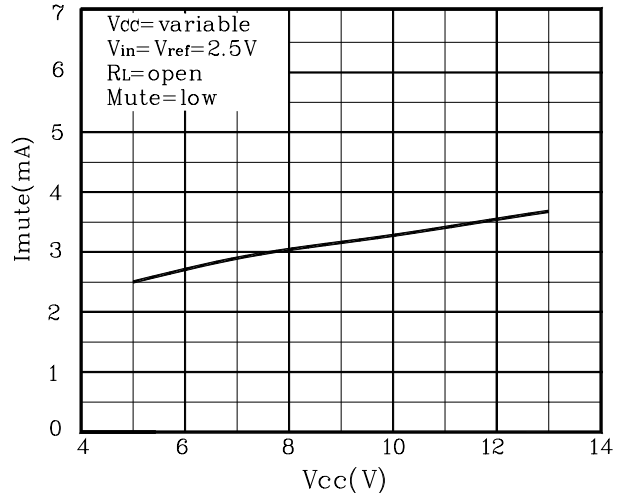

Fig. 3. VCC vs Avf

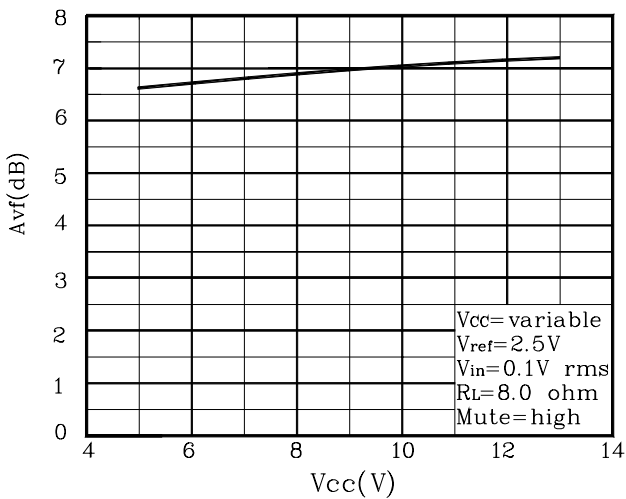

Fig. 4. VCC vs Vom

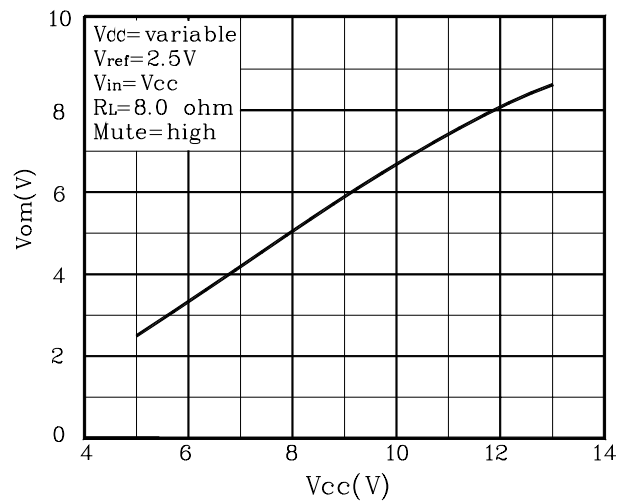

Fig. 5. IL vs Vcesat_upper

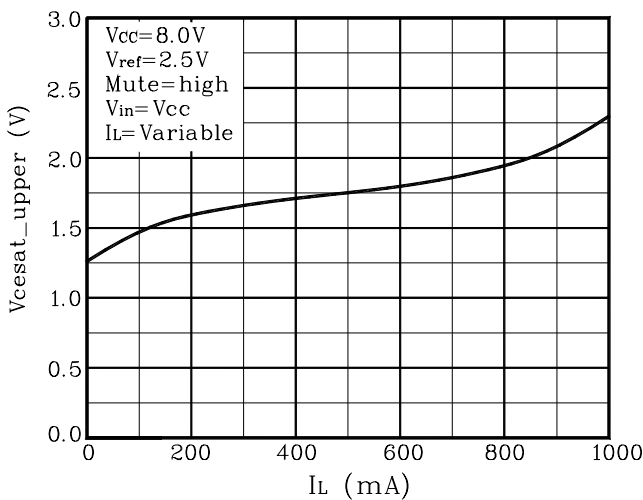
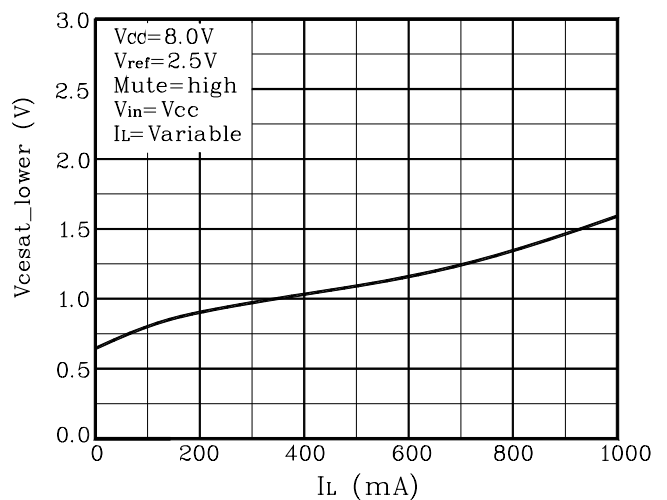

Fig. 6. IL vs Vcesat_lower



Electrical Characteristic Curves (Cont.)

Fig. 7. VCC vs Vreg

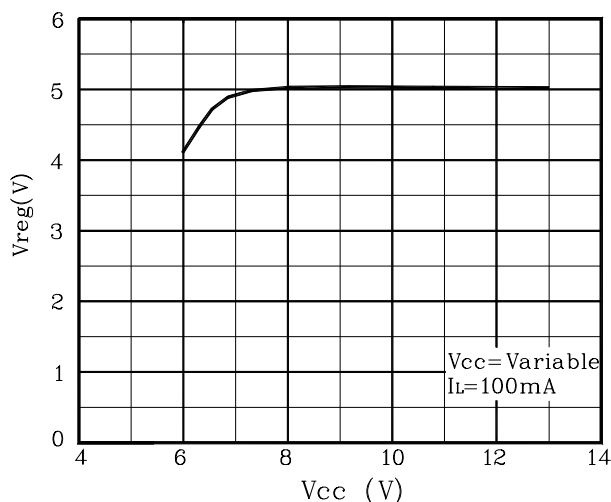

Fig. 8. IL vs Vreg

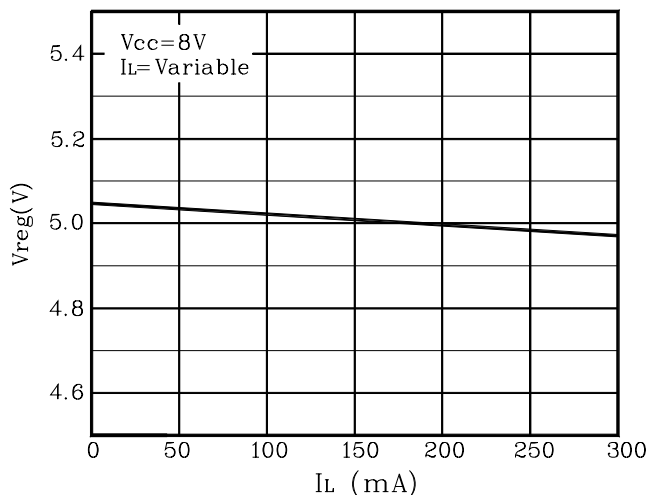

Fig. 9. VCC vs Vo

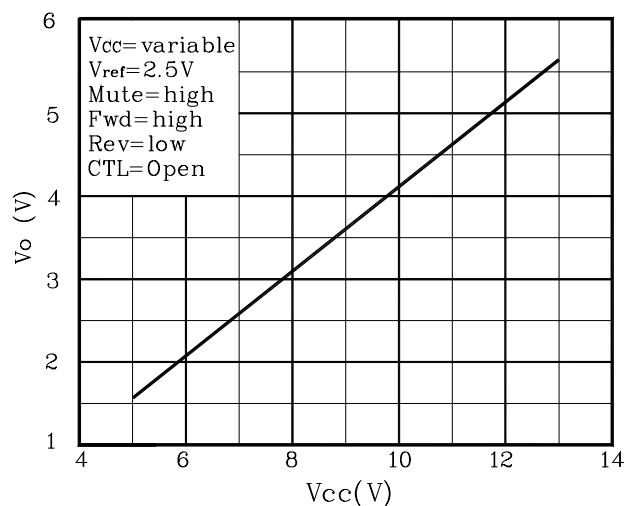

Fig. 10. Vctl vs Vo

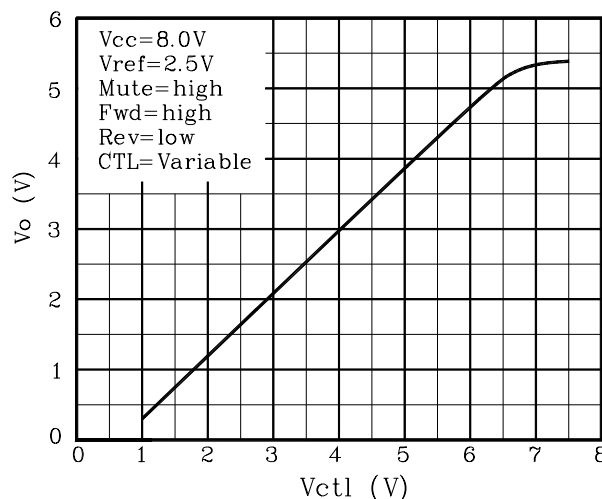

Fig. 11. Temperature vs Icc

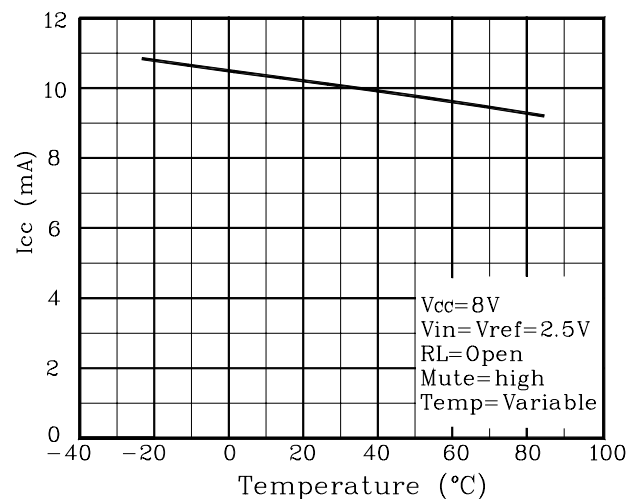
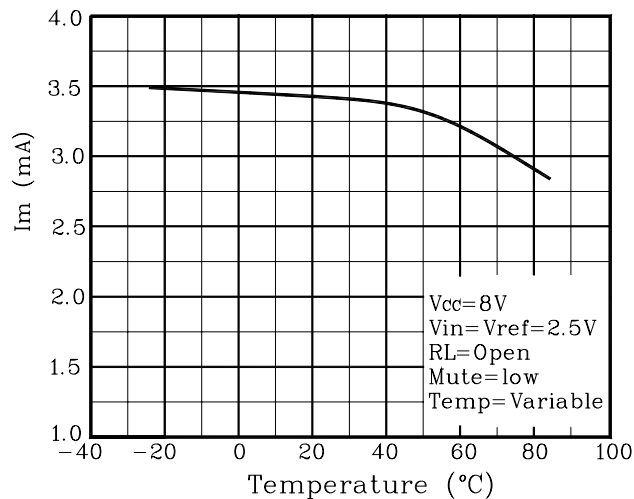

Fig. 12. Temperature vs Im



Electrical Characteristic Curves

Fig. 13. Temperature vs Avf

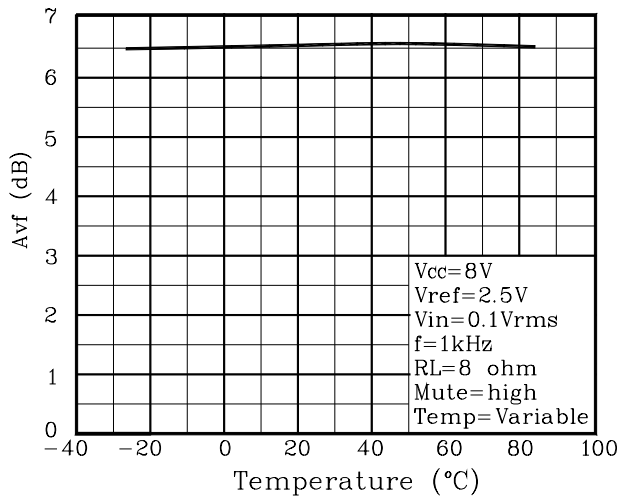

Fig. 14. Temperature vs Vom

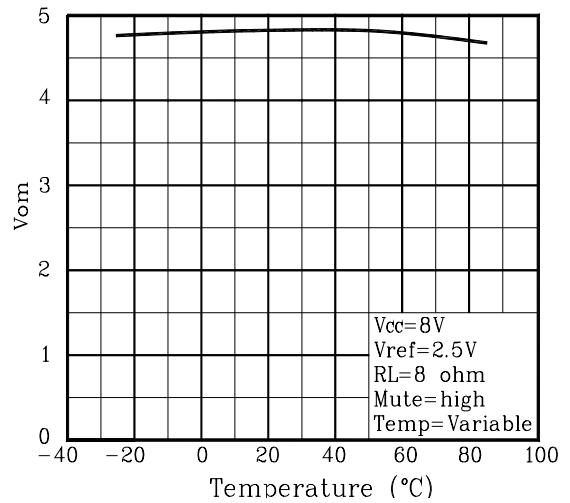

Fig. 15. Temperature vs Vo

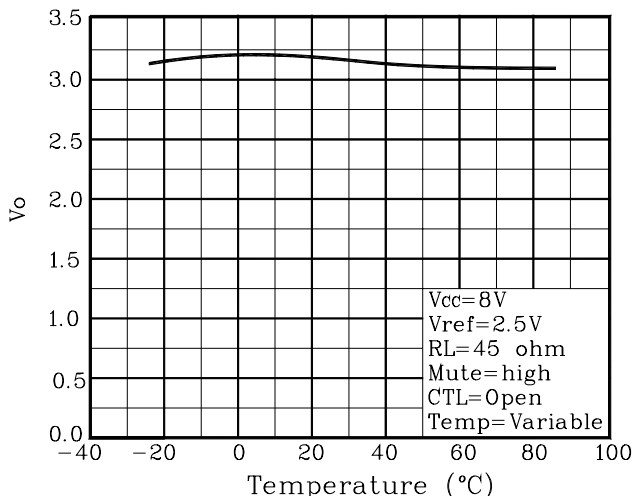
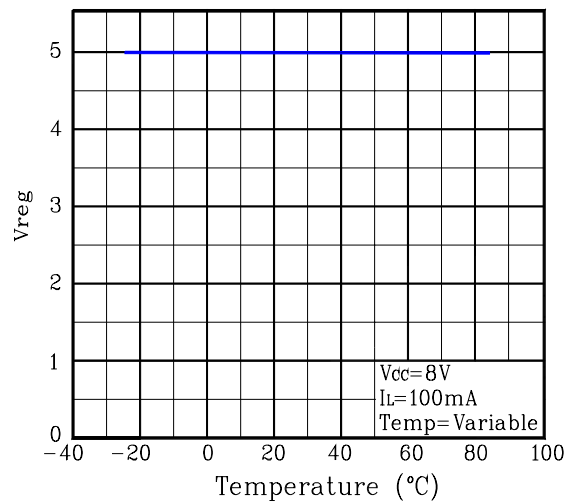
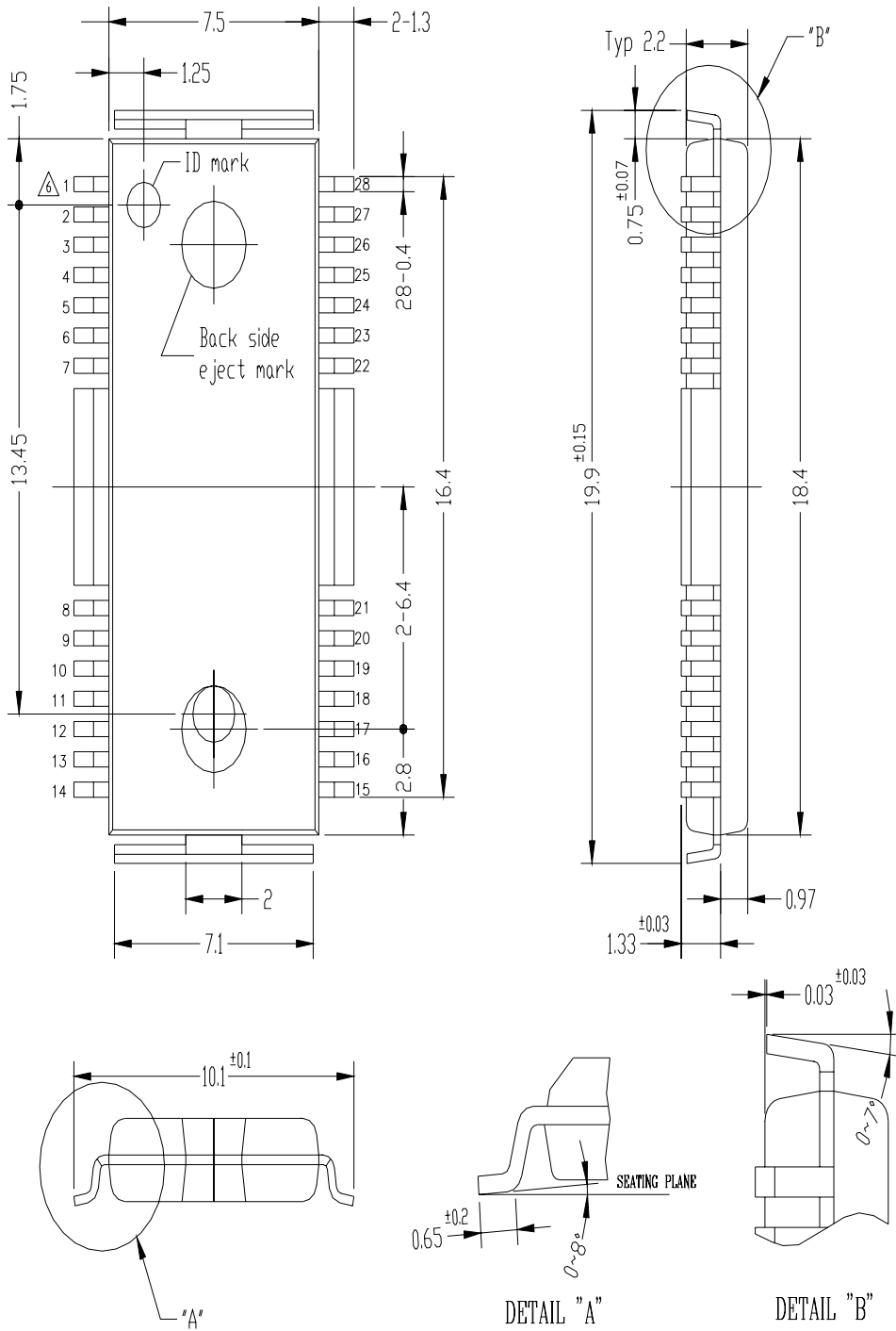

Fig. 16. Temperature vs Vreg



PACKAGE DIMENSION

unit : mm



These AUK products are intended for usage in general electronic equipments(Office and communication equipment, measuring equipment, domestic electrification, etc.).

Please make sure that you consult with us before you use these AUK products in equipments which require high quality and/or reliability, and in equipments which could have major impact to the welfare of human life(atomic energy control, airplane, spaceship, traffic signal, combustion central, all types of safety device, etc.).

AUK cannot accept liability to any damage which may occur in case these AUK products were used in the mentioned equipments without prior consultation with AUK.