

THREE TERMINAL ADJUSTABLE CURRENT SOURCES

- OPERATES from 1V to 40V
- 0.02% V CURRENT REGULATION
- PROGRAMMABLE from 1 μ A to 10mA
- \pm 3% INITIAL ACCURACY

DESCRIPTION

The LM134/LM234/LM334 are 3-terminal adjustable current sources characterized by :

- an operating current range of 10000 : 1
- an excellent current regulation
- a wide dynamic voltage range of 1V to 40V

The current is determined by an external resistor without requiring other external components.

Reverse voltages of up to 20V will only draw a current of several microamperes. This enables the circuit to operate as a rectifier and as a source of current in a.c. applications.

For the LM134/LM234/LM334, the voltage on the control pin is 64mV at +25 $^{\circ}$ C and is directly proportional to the absolute temperature ($^{\circ}$ K). The simplest external resistor connection generates a current with \approx 0.33%/ $^{\circ}$ C temperature dependence. Zero drift can be obtained by adding an additional resistor and a diode to the external circuit.

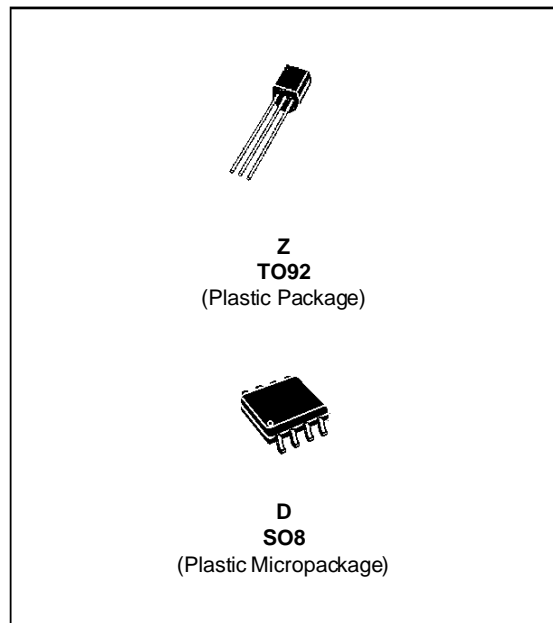

ORDER CODES

Part Number	Temperature Range	Package	
		Z	D
LM134	-55 $^{\circ}$ C, +125 $^{\circ}$ C	•	•
LM234	-25 $^{\circ}$ C, +100 $^{\circ}$ C	•	•
LM334	0 $^{\circ}$ C, +70 $^{\circ}$ C	•	•

Example : LM134Z

PIN CONNECTIONS

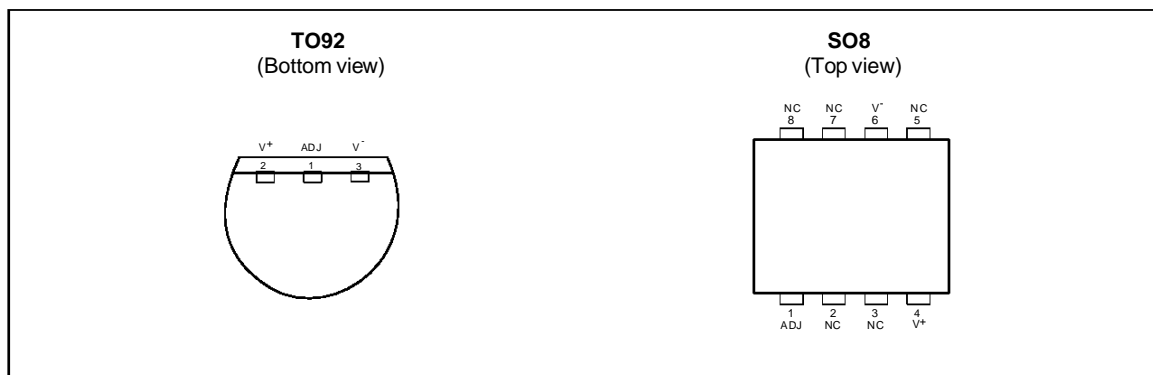

SCHEMATIC DIAGRAM

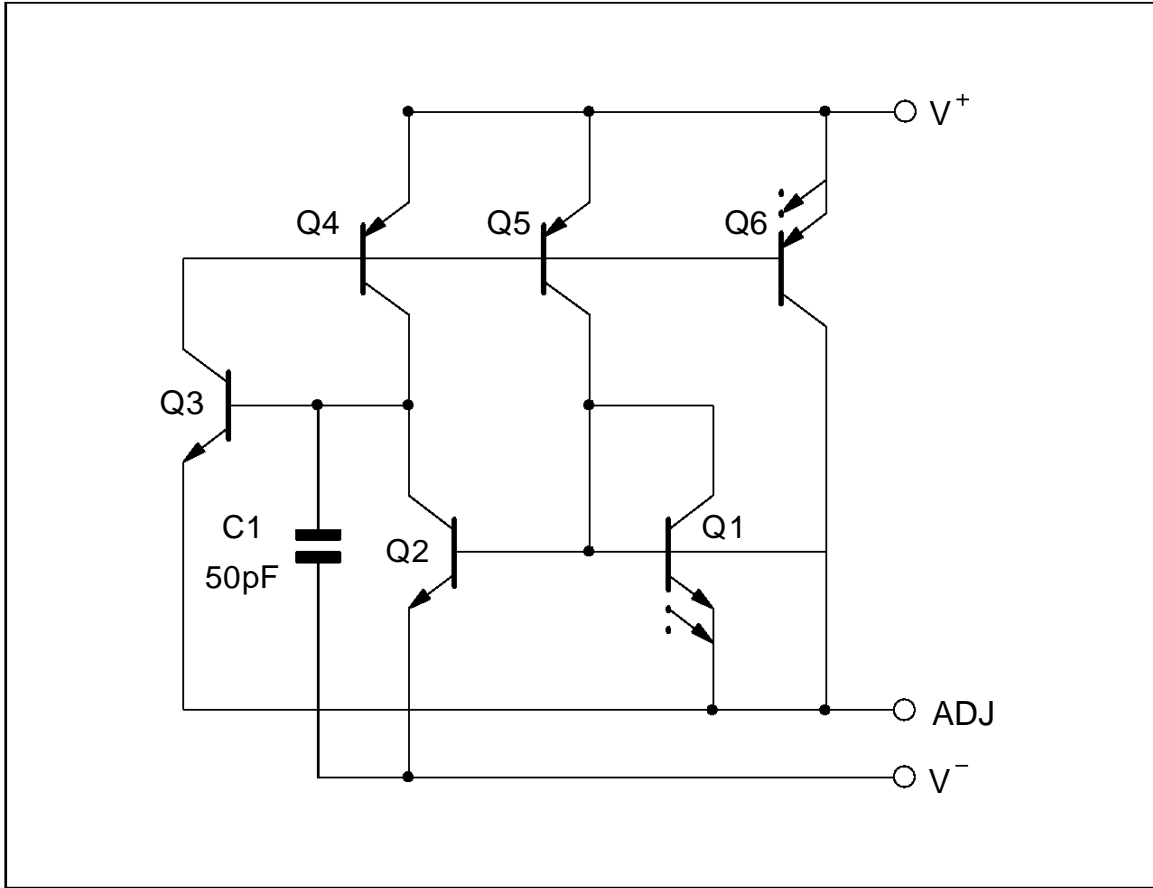

ABSOLUTE MAXIMUM RATING

Symbol	Parameter	LM134 - LM234	LM334	Unit
	Voltage V^+ to V^- Forward Reverse	40 20	30 20	V
V_{ADJ}	ADJ Pin to V^- Voltage	5	5	V
I_{SET}	Set Current	10	10	mA
P_{tot}	Power Dissipation	400	400	mW
T_{stg}	Storage Temperature Range	-65 to +150		°C
T_{oper}	Operating Free-air Temperature Range	LM134 LM234 LM334	-55 to +125 -25 to +100 0 to +70	°C

ELECTRICAL CHARACTERISTICS

T_j = +25°C with pulse testing so that junction temperature does not change during testing (unless otherwise specified)

Parameter	LM134 - LM234			LM334			Unit
	Min.	Typ.	Max.	Min.	Typ.	Max.	
Set Current Error (V ⁺ = +2.5V) - (note 1) 10µA ≤ I _{SET} ≤ 1mA 1mA ≤ I _{SET} ≤ 5mA 2µA ≤ I _{SET} ≤ 10µA			3 5 8			6 8 12	%
Ratio of Set Current to V ⁻ Current 10µA ≤ I _{SET} ≤ 1mA 1mA ≤ I _{SET} ≤ 5mA 2µA ≤ I _{SET} ≤ 10µA	14	18 14 14	23	14	18 14 14	26	
Minimum Operating Voltage 2µA ≤ I _{SET} ≤ 100µA 100µA ≤ I _{SET} ≤ 1mA 1mA ≤ I _{SET} ≤ 5mA		0.8 0.9 1			0.8 0.9 1		V
Average change in set current with input voltage 2µA ≤ I _{SET} ≤ 1mA +1.5V ≤ V ⁺ ≤ +5V +5V ≤ V ⁺ ≤ +40V 1mA ≤ I _{SET} ≤ 5mA +1.5V ≤ V ⁺ ≤ +5V +5V ≤ V ⁺ ≤ +40V		0.02 0.01	0.05 0.03		0.02 0.01	0.1 0.05	% / V
Temperature Dependence of set current - (note 2) 25µA ≤ I _{SET} ≤ 1mA	0.96 T	T	1.04 T	0.96 T	T	1.04 T	
Effective Shunt Capacitance		15			15		pF

- Notes :**
- Set current is the current flowing into the V⁺ pin. It is determined by the following formula I_{set} = 67.7mV/R_{set} (T_j = +25°C). Set current error is expressed as a percent deviation from this amount.
 - I_{set} is directly proportional to absolute temperature (°K). I_{set} at any temperature can be calculated from I_{set} = I_o (T/T_o) where I_o is I_{set} measured at T_o (°K).

OUTPUT IMPEDANCE

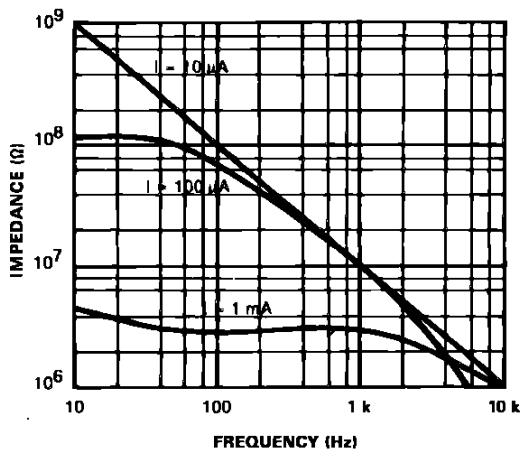

MAXIMUM SLEW RATE FOR LINEAR OPERATION

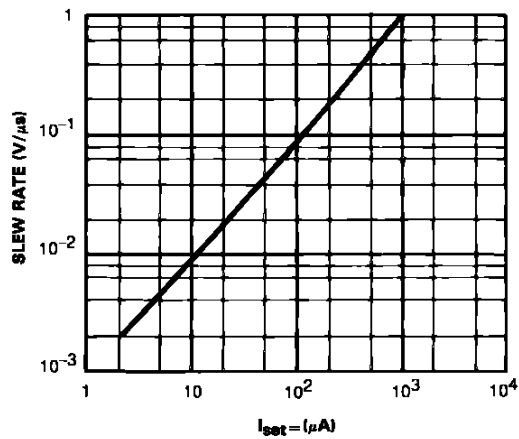

START UP

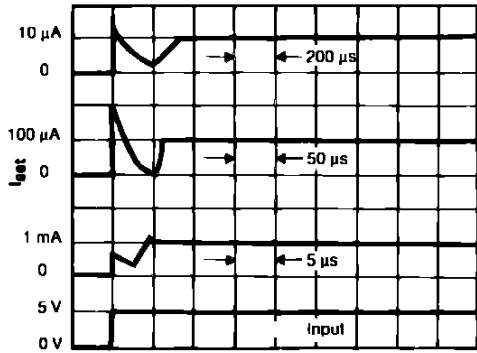

TIME (SCALE CHANGES AT EACH CURRENT LEVEL).

TRANSIENT RESPONSE

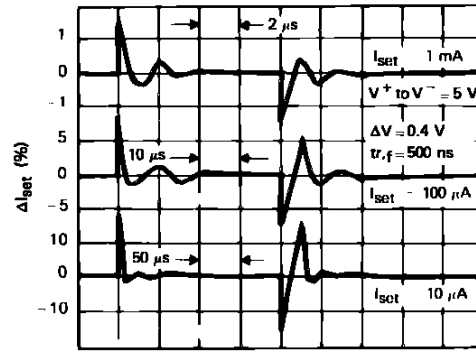

TIME (SCALE CHANGES AT EACH CURRENT LEVEL).

VOLTAGE ACROSS R_{set}

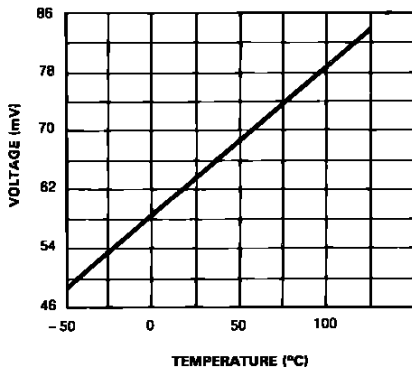

CURRENT NOISE

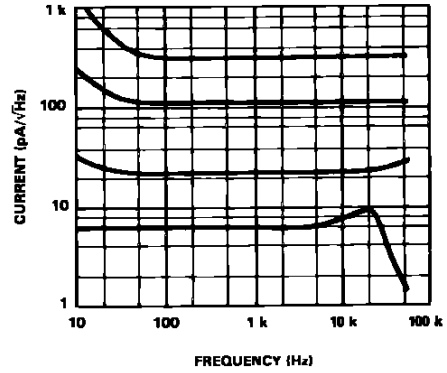

TURN-ON VOLTAGE

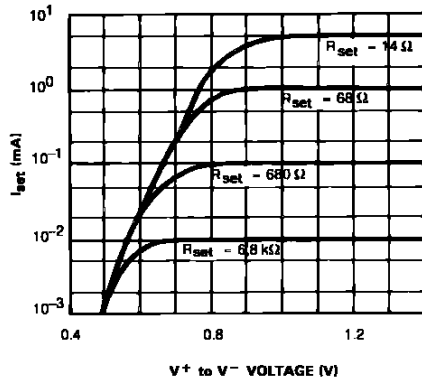

RATIO OF I_{set} to V^- CURRENT

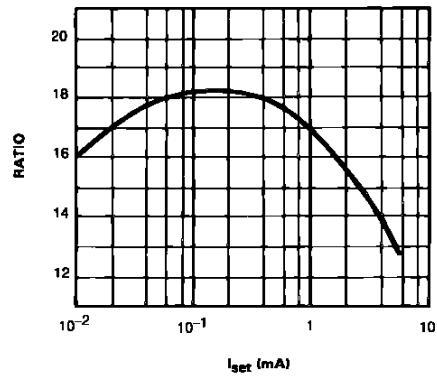

APPLICATION HINT

SLEW RATE

At slew rates above a threshold (see curve) the LM134, LM234, LM334 can have a non-linear current characteristic. The slew rate at which this takes place is directly proportional to I_{set} . At $I_{set} = 10\mu\text{A}$, $dv/dt \text{ max.} = 0.01\text{V}/\mu\text{S}$; at $I_{set} = 1\text{mA}$, $dv/dt \text{ max.} = 1\text{V}/\mu\text{S}$. Slew rates of more than $1\text{V}/\mu\text{S}$ do not damage the circuit nor do they produce high currents.

THERMAL EFFECTS

Internal heating can have a significant effect on current regulation for an I_{set} above $100\mu\text{A}$. For example, each increase of 1V in the voltage across the LM134 at $I_{set} = 1\text{mA}$ will increase the junction temperature by $\approx 0.4^\circ\text{C}$ (in still air). The output current (I_{set}) has a temperature coefficient of about $0.33\%/^\circ\text{C}$. Thus the change in current due to the increase in temperature will be $(0.4)(0.33) = 0.132\%$. This is a degradation of $10:1$ in regulation versus the true electrical effects. Thermal effects should be taken into account when d.c. regulation is critical and I_{set} is higher than $100\mu\text{A}$. The dissipation of the connections of CB-97 package can reduce this thermal effect by a coefficient of more than 3.

SHUNT CAPACITANCE

In certain applications, the 15pF value for the shunt capacitance should be reduced:

- because of loading problems,
- because of limitation of the output impedance of the current source in a.c. applications. This reduction of the capacitance can be easily carried out by adding a FET as indicated in the typical applications. The value of this capacitance can be reduced by at least 3pF and regulation can be improved by an order of magnitude without any modification of the d.c. characteristics (except for the minimum input voltage).

NOISE

The current noise produced by LM134, LM234, LM334 is about 4 times that of a transistor. If the LM134, LM234, LM334 is utilized as an active load for a transistor amplifier, the noise at the input will increase by about 12dB . In most cases this is acceptable, and a single amplifier can be built with a voltage gain higher than 2000.

LEAD RESISTANCE

The sense voltage which determines the current of the LM134, LM234, LM334, is less than 100mV . At this level, the effects of the thermocouple and the

connection resistance should be reduced by locating the current setting resistor close to the device. Do not use sockets for the ICs. A contact resistance of 0.7Ω is sufficient to decrease the output current by 1% at the 1mA level.

SENSING TEMPERATURE

The LM134, LM234, LM334 are excellent remote controlled temperature sensors because their operation as sources of current preserves their accuracy even in the case of long connecting wires. The output current is directly proportional to the absolute temperature in degrees Kelvin according to the following equation.

$$I_{set} = \frac{(227\mu\text{V}/^\circ\text{K})(T)}{R_{set}}$$

The calibration of the LM134, LM234, LM334 is simplified by the fact that most of the initial accuracy is due to gain limitation (slope error) and not an offset. Gain adjustment is a one point trim because the output of the device extrapolates to zero at 0°K .

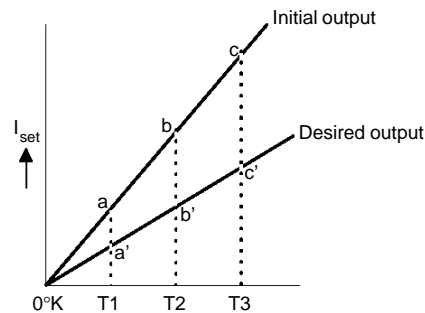

This particularity of the LM134, LM234, LM334 is illustrated in the above diagram. Line abc represents the sensor current before adjustment and line a'b'c' represents the desired output. An adjustment of the gain provided at T_2 will move the output from b to b' and will correct the slope at the same time so that the output at T_1 and T_3 will be correct. This gain adjustment can be carried out by means of R_{set} or the load resistor utilized in the circuit. After adjustment, the slope error should be less than 1% . A low temperature coefficient for R_{set} is necessary to keep this accuracy. A $33\text{ppm}/^\circ\text{C}$ temperature drift of R_{set} will give an error of 1% on the slope because the resistance follows the same temperature variations as the LM134, LM234, LM334. Three wires are required to isolate R_{set} from the LM134, LM234, LM334. Since this solution is not recommended. Metal-film resistors with a drift less than $20\text{ppm}/^\circ\text{C}$ are now available. Wirewound resistors can be utilized when very high stability is required.

TYPICAL APPLICATIONS

Figure 1 : Basic 2-terminal Current Source

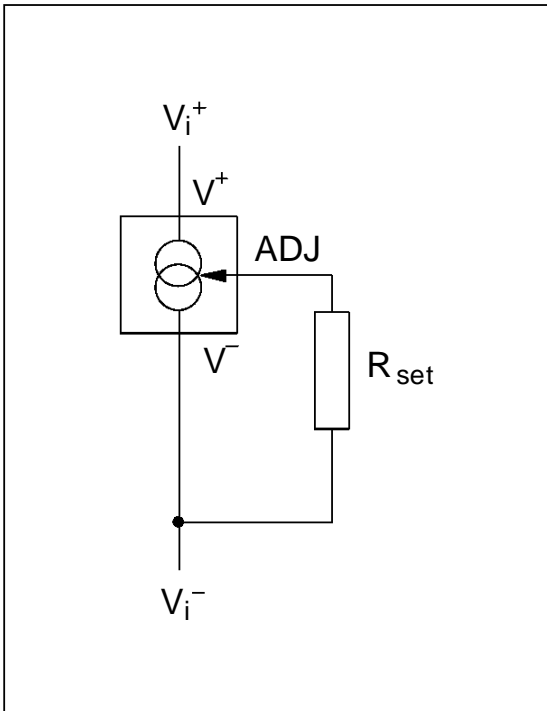

Figure 3 : Terminating Remote Sensor for Voltage Output

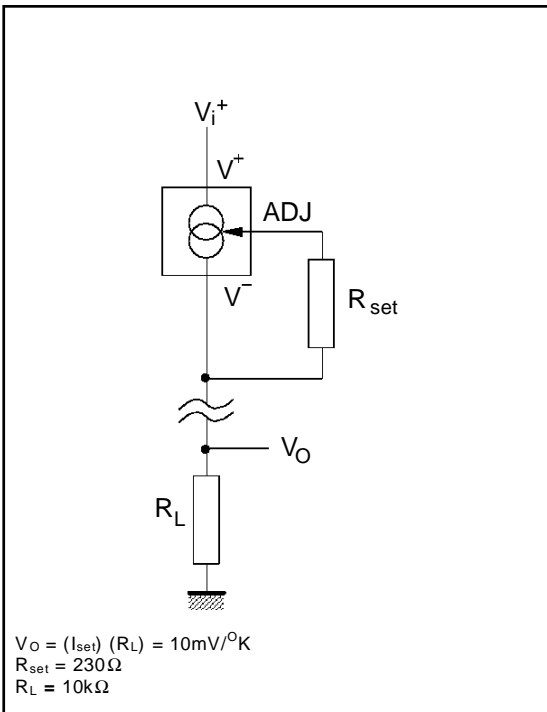

Figure 2 : Alternate Trimming Technique

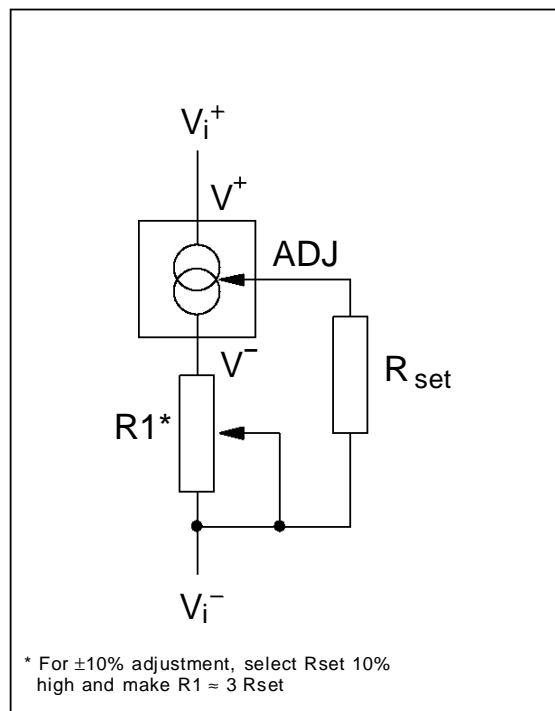

Figure 4 : Zero Temperature Coefficient Current Source

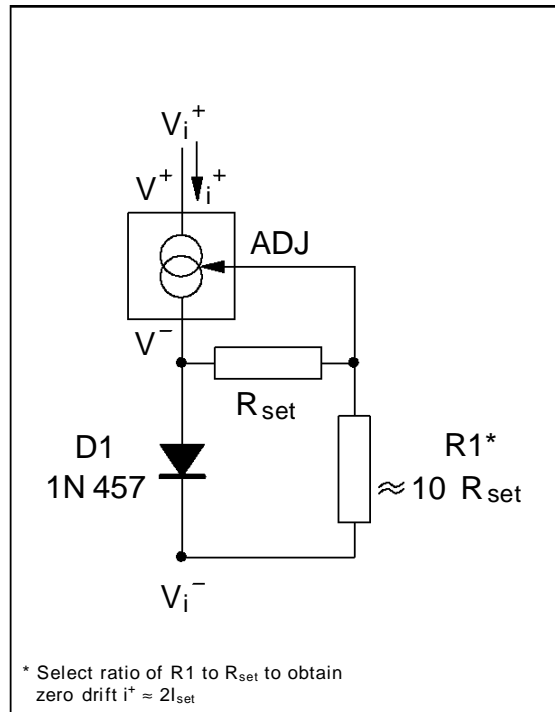

Figure 5 : Low Output Impedance Thermometer

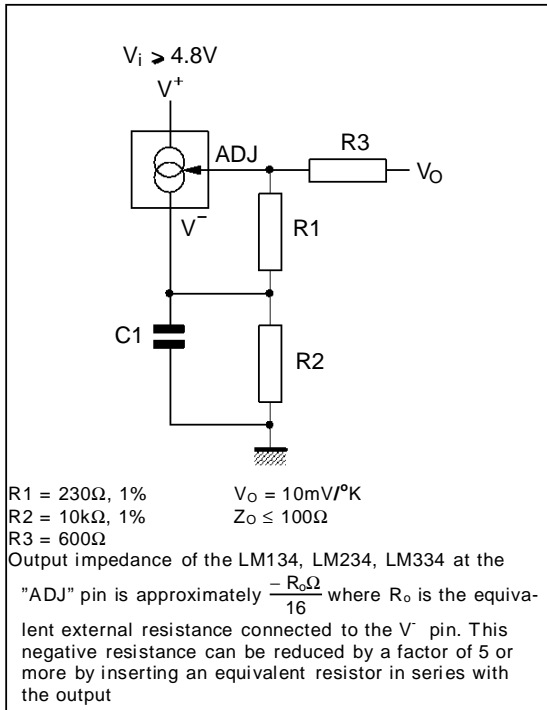

Figure 6 : Low Output Impedance Thermometer

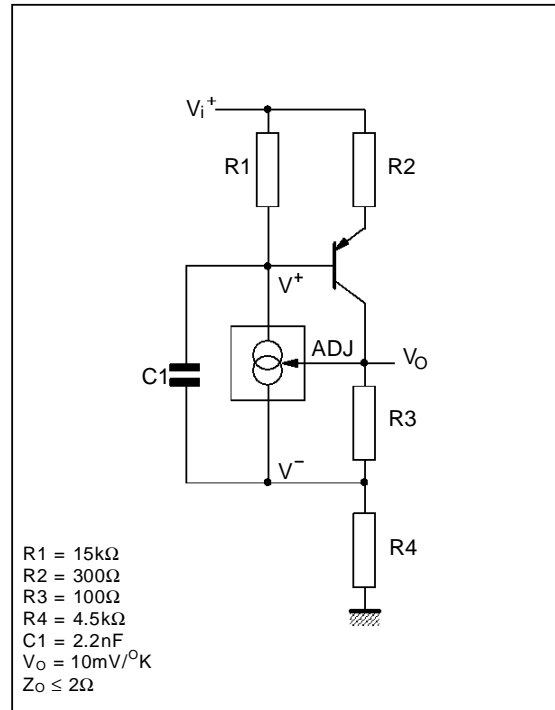

Figure 7 : Micropower Bias

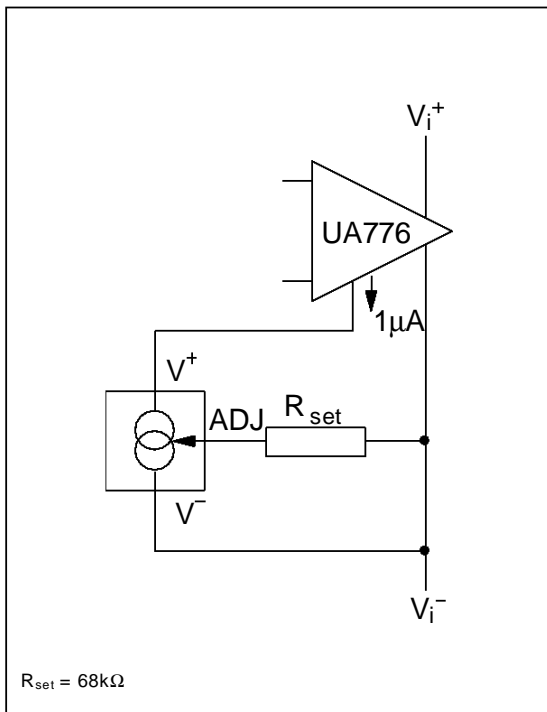

Figure 8 : Low Input Voltage Reference Driver

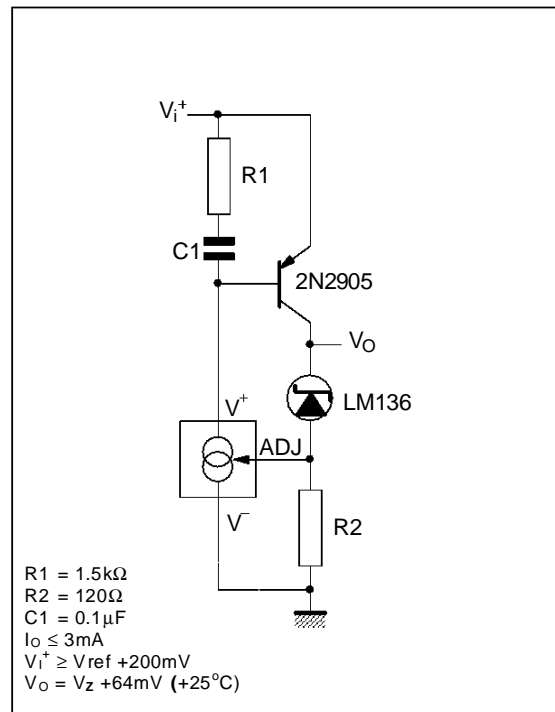

Figure 9 : In-line Current Limiter

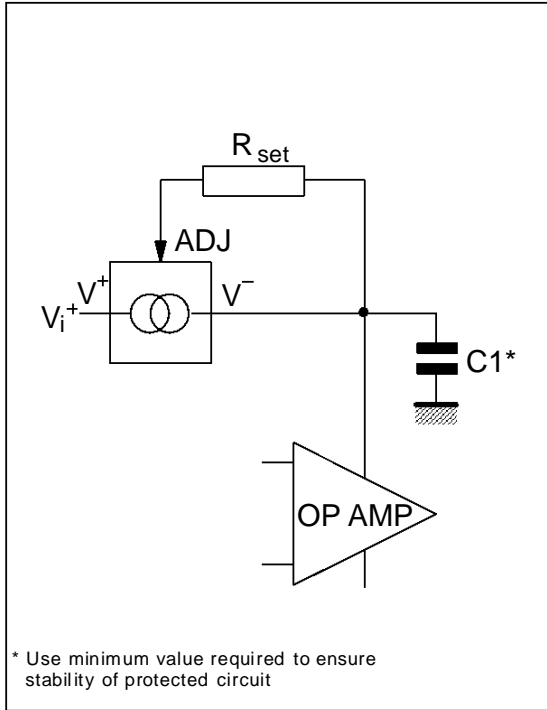
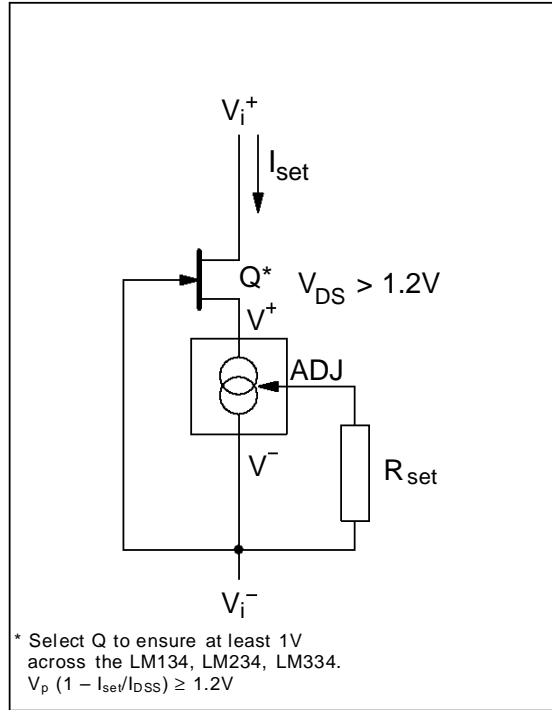
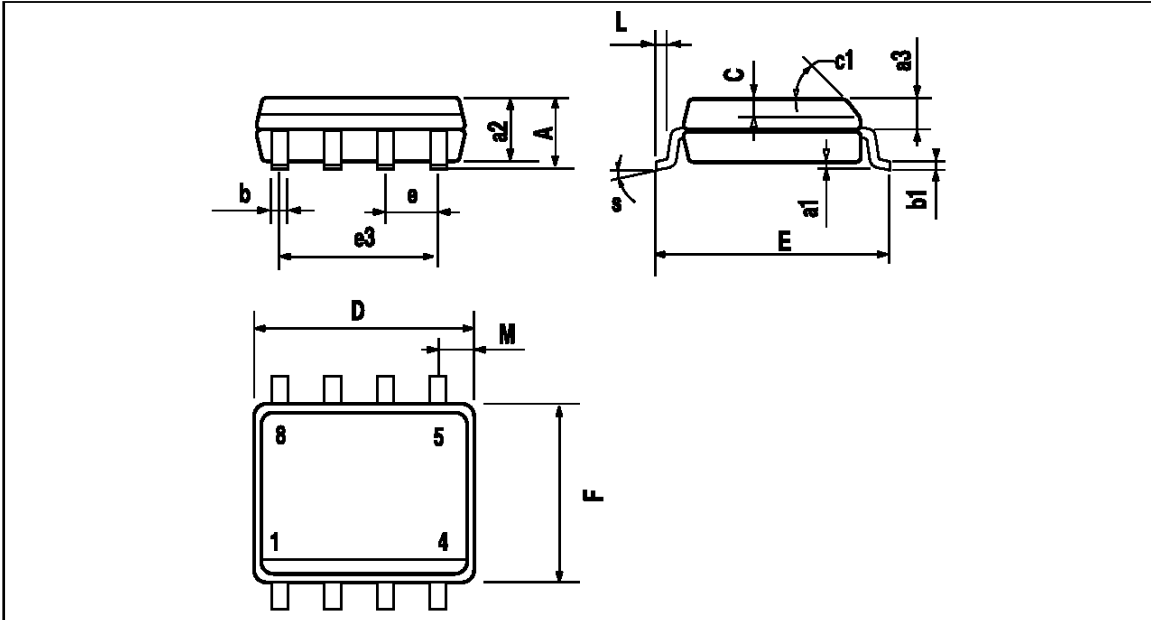

Figure 10 : Fet Cascading for Low Capacitance



PACKAGE MECHANICAL DATA
8 PINS - PLASTIC MICROPACKAGE (SO)



PM-S08.EPS

Dimensions	Millimeters			Inches		
	Min.	Typ.	Max.	Min.	Typ.	Max.
A			1.75			0.069
a1	0.1		0.25	0.004		0.010
a2			1.65			0.065
a3	0.65		0.85	0.026		0.033
b	0.35		0.48	0.014		0.019
b1	0.19		0.25	0.007		0.010
C	0.25		0.5	0.010		0.020
c1	45° (typ.)					
D	4.8		5.0	0.189		0.197
E	5.8		6.2	0.228		0.244
e		1.27			0.050	
e3		3.81			0.150	
F	3.8		4.0	0.150		0.157
L	0.4		1.27	0.016		0.050
M			0.6			0.024
S	8° (max.)					

SO8.TBL

PACKAGE MECHANICAL DATA
3 PINS - PLASTIC PACKAGE TO92

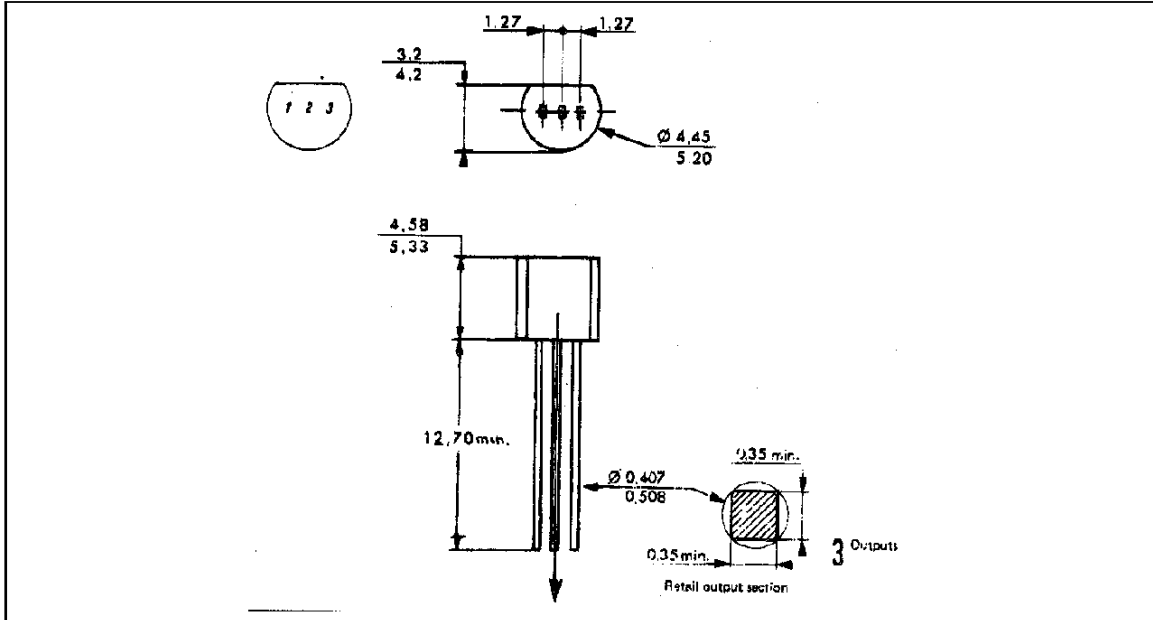

Dimensions	Millimeters			Inches		
	Min.	Typ.	Max.	Min.	Typ.	Max.
L		1.27			0.05	
B	3.2	3.7	4.2	0.126	0.1457	0.1654
O1	4.45	5.00	5.2	0.1752	0.1969	0.2047
C	4.58	5.03	5.33	0.1803	0.198	0.2098
K	12.7			0.5		
O2	0.407	0.5	0.508	0.016	0.0197	0.02
a	0.35			0.0138		

Information furnished is believed to be accurate and reliable. However, SGS-THOMSON Microelectronics assumes no responsibility for the consequences of use of such information nor for any infringement of patents or other rights of third parties which may result from its use. No license is granted by implication or otherwise under any patent or patent rights of SGS-THOMSON Microelectronics. Specification mentioned in this publication are subject to change without notice. This publication supersedes and replaces all information previously supplied. SGS-THOMSON Microelectronics products are not authorized for use as critical components in life support devices or systems without express written approval of SGS-THOMSON Microelectronics.

© 1997 SGS-THOMSON Microelectronics – Printed in Italy – All Rights Reserved

SGS-THOMSON Microelectronics GROUP OF COMPANIES
Australia - Brazil - Canada - China - France - Germany - Hong Kong - Italy - Japan - Korea - Malaysia - Malta - Morocco
The Netherlands - Singapore - Spain - Sweden - Switzerland - Taiwan - Thailand - United Kingdom - U.S.A.