

LOW POWER QUAD OPERATIONAL AMPLIFIERS

- WIDE GAIN BANDWIDTH / 1.3MHz
- LARGE VOLTAGE GAIN : 100dB
- VERY LOW SUPPLY CURRENT/AMPLI : 375 μ A
- LOW INPUT BIAS CURRENT : 20nA
- LOW INPUT OFFSET VOLTAGE : 3mV max.
- LOW INPUT OFFSET CURRENT : 2nA
- WIDE POWER SUPPLY RANGE :
 SINGLE SUPPLY : +3V TO +30V
 DUAL SUPPLIES : ± 1.5 V TO ± 15 V
- INPUT COMMON-MODE VOLTAGE RANGE INCLUDES GROUND
- ESD INTERNAL PROTECTION : 2kV

DESCRIPTION

These circuits consist of four independent, high gain, internally frequency compensated operational amplifiers. They operate from a single power supply over a wide range of voltages. Operation from split power supplies is also possible and the low power supply current drain is independent of the magnitude of the power supply voltage.

All the pins are protected against electrostatic discharges up to 2000V (as a consequence, the input voltages must not exceed the magnitude of V_{CC}^+ or V_{CC}^- .)

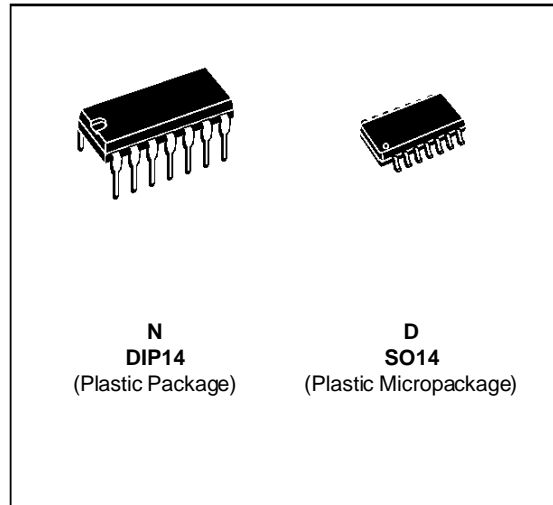

ORDER CODES

Part Number	Temperature Range	Package	
		N	D
LM124A	-55°C, +125°C	•	•
LM224A	-40°C, +105°C	•	•
LM324A	0°C, +70°C	•	•

Example : LM224AN

PIN CONNECTIONS (top view)

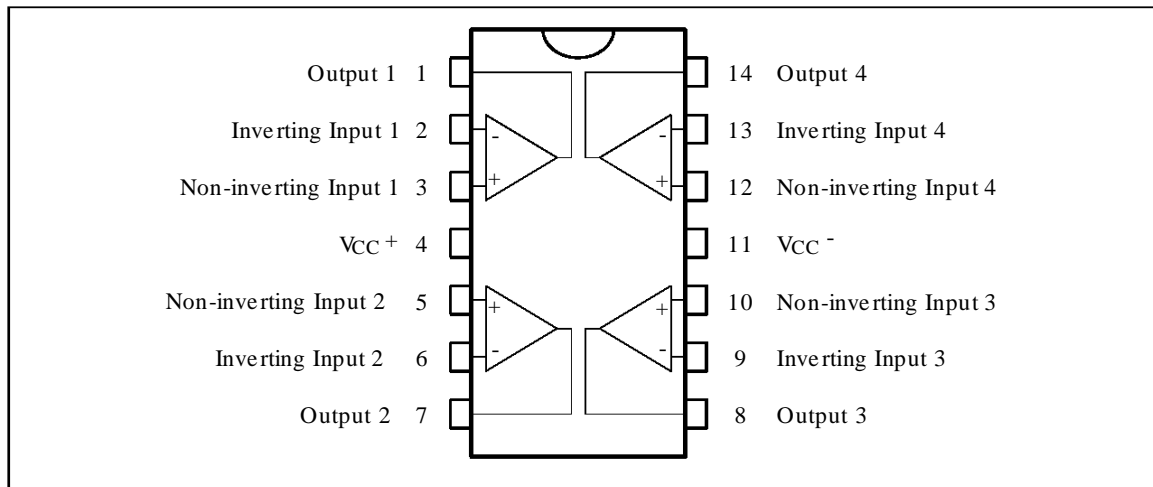

LM124A - LM224A - LM324A

SCHEMATIC DIAGRAM (1/4 LM124A)

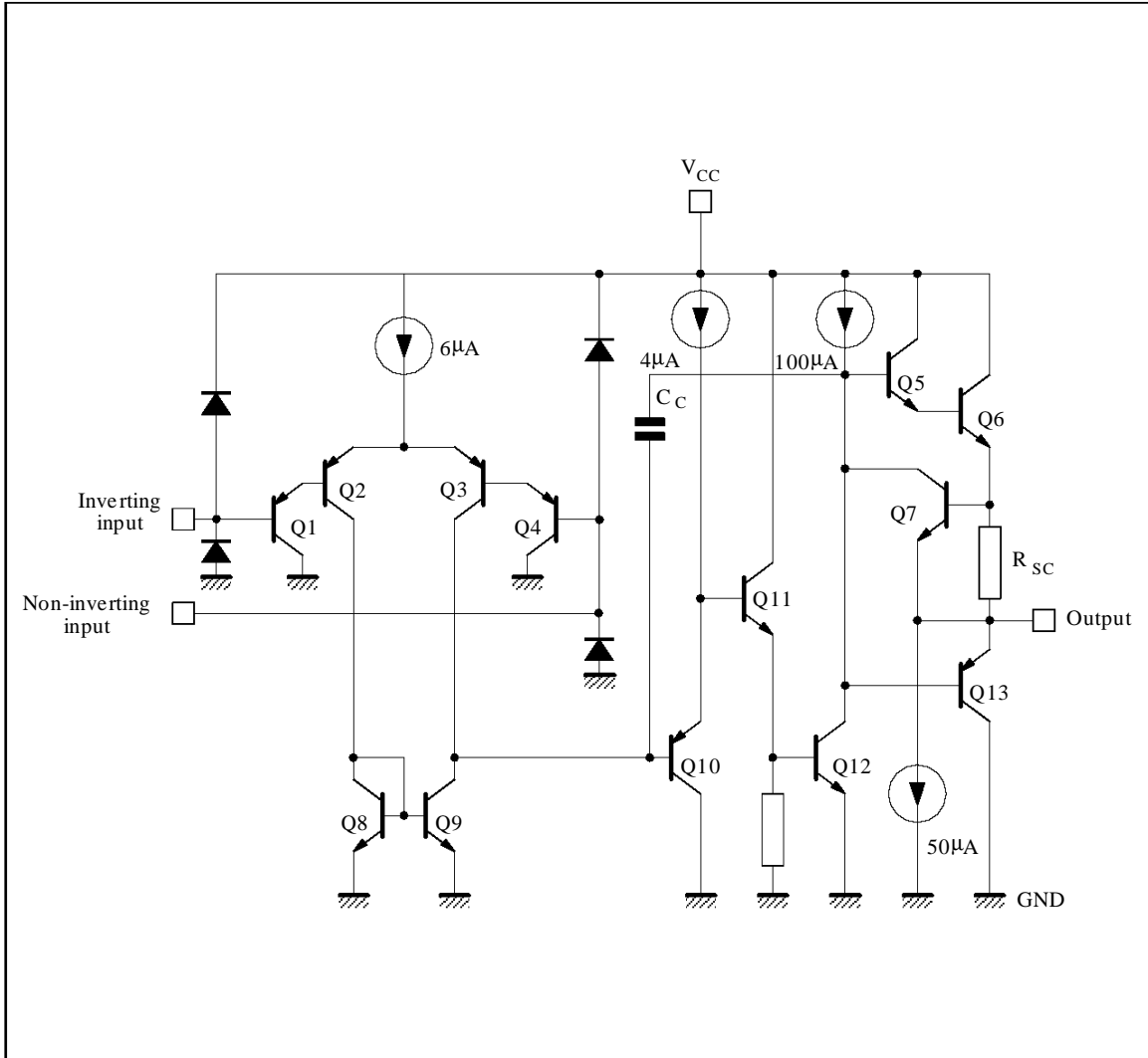

ABSOLUTE MAXIMUM RATINGS

Symbol	Parameter	LM124A	LM224A	LM324A	Unit
V_{cc}	Supply Voltage	±16 or 32			V
V_i	Input Voltage	-0.3 to +32			V
V_{id}	Differential Input Voltage - (*)	+32	+32	+32	V
P_{tot}	Power Dissipation	500	500	500	mW
		-	400	400	mW
-	Output Short-circuit Duration - (note 1)	Infinite			
I_{in}	Input Current - (note 6)	50	50	50	mA
T_{oper}	Operating Free Air Temperature Range	-55 to +125	-40 to +105	0 to +70	°C
T_{stg}	Storage Temperature Range	-65 to +150	-65 to +150	-65 to +150	°C

(*) - Either or both input voltages must not exceed the magnitude of V_{cc}^+ or V_{cc}^- .

ELECTRICAL CHARACTERISTICS

$V_{CC}^+ = +5V$, $V_{CC}^- = \text{Ground}$, $V_O = 1.4V$, $T_{amb} = +25^\circ C$ (unless otherwise specified)

Symbol	Parameter	LM124A - LM224A - LM324A			Unit
		Min.	Typ.	Max.	
V_{io}	Input Offset Voltage (note 3) $T_{amb} = +25^\circ C$ $T_{min.} \leq T_{amb} \leq T_{max.}$		2	3 5	mV
I_{io}	Input Offset Current $T_{amb} = +25^\circ C$ $T_{min.} \leq T_{amb} \leq T_{max.}$		2	20 40	nA
I_{ib}	Input Bias Current (note 2) $T_{amb} = +25^\circ C$ $T_{min.} \leq T_{amb} \leq T_{max.}$		20	100 200	nA
A_{vd}	Large Signal Voltage Gain ($V_{CC}^+ = +15V$, $R_L = 2k\Omega$, $V_O = 1.4V$ to $11.4V$) $T_{amb} = +25^\circ C$ $T_{min.} \leq T_{amb} \leq T_{max.}$	50 25	100		V/mV
SVR	Supply Voltage Rejection Ratio ($R_S \leq 10k\Omega$) ($V_{CC}^+ = 5V$ to $30V$) $T_{amb} = +25^\circ C$ $T_{min.} \leq T_{amb} \leq T_{max.}$	65 65	110		dB
I_{CC}	Supply Current, all Amp, no load $T_{amb} = +25^\circ C$ $T_{min.} \leq T_{amb} \leq T_{max.}$		$V_{CC} = +5V$ 0.7 $V_{CC} = +30V$ 1.5 $V_{CC} = +5V$ 0.8 $V_{CC} = +30V$ 1.5	1.2 3 1.2 3	mA
V_{icm}	Input Common Mode Voltage Range ($V_{CC} = +30V$) - (note 4) $T_{amb} = +25^\circ C$ $T_{min.} \leq T_{amb} \leq T_{max.}$	0 0		$V_{CC} - 1.5$ $V_{CC} - 2$	V
CMR	Common-mode Rejection Ratio ($R_S \leq 10k\Omega$) $T_{amb} = +25^\circ C$ $T_{min.} \leq T_{amb} \leq T_{max.}$	70 60	80		dB
I_{source}	Output Current Source ($V_{id} = +1V$) $V_{CC} = +15V$, $V_o = +2V$	20	40	70	mA
I_{sink}	Output Sink Current ($V_{id} = -1V$) $V_{CC} = +15V$, $V_o = +2V$ $V_{CC} = +15V$, $V_o = +0.2V$	10 12	20 50		mA μA

ELECTRICAL CHARACTERISTICS (continued)

Symbol	Parameter	LM124A - LM224A - LM324A			Unit
		Min.	Typ.	Max.	
V _{OH}	High Level Output Voltage (V _{CC} = +30V) T _{amb} = +25°C T _{min.} ≤ T _{amb} ≤ T _{max.} R _L = 2kΩ	26	27		V
	T _{amb} = +25°C T _{min.} ≤ T _{amb} ≤ T _{max.} R _L = 10kΩ	26	28		
	(V _{CC} = +5V, R _L = 2kΩ) T _{amb} = +25°C T _{min.} ≤ T _{amb} ≤ T _{max.}	27			
		3.5			
		3			
V _{OL}	Low Level Output Voltage (R _L = 10kΩ) T _{amb} = +25°C T _{min.} ≤ T _{amb} ≤ T _{max.}		5	20 20	mV
SR	Slew Rate (V _{CC} = 15V, V _I = 0.5 to 3V, R _L = 2kΩ, C _L = 100pF, unity gain)		0.4		V/μs
GBP	Gain Bandwidth Product (V _{CC} = 30V f = 100kHz, V _{in} = 10mV R _L = 2kΩ, C _L = 100pF)		1.3		MHz
THD	Total Harmonic Distortion (f = 1kHz, A _V = 20dB, R _L = 2kΩ, V _O = 2V _{pp} C _L = 100pF, V _{CC} = 30V)		0.015		%
e _n	Equivalent Input Noise Voltage (f = 1kHz, R _s = 100Ω, V _{CC} = 30V)		40		$\frac{nV}{\sqrt{Hz}}$
DV _{io}	Input Offset Voltage Drift		7	30	μV/°C
DI _{io}	Input Offset Current Drift		10	200	pA/°C
V _{O1} /V _{O2}	Channel Separation (note 5) 1kHz ≤ f ≤ 20kHz		120		dB

- Notes :**
- Short-circuits from the output to V_{CC} can cause excessive heating if V_{CC} > 15V. The maximum output current is approximately 40mA independent of the magnitude of V_{CC}. Destructive dissipation can result from simultaneous short-circuit on all amplifiers.
 - The direction of the input current is out of the IC. This current is essentially constant, independent of the state of the output so no loading change exists on the input lines.
 - V_o = 1.4V, R_s = 0Ω, 5V < V_{CC}⁺ < 30V, 0 < V_{ic} < V_{CC}⁺ - 1.5V
 - The input common-mode voltage of either input signal voltage should not be allowed to go negative by more than 0.3V. The upper end of the common-mode voltage range is V_{CC}⁺ - 1.5V, but either or both inputs can go to +32V without damage.
 - Due to the proximity of external components insure that coupling is not originating via stray capacitance between these external parts. This typically can be detected as this type of capacitance increases at higher frequencies.
 - This input current only exists when the voltage at any of the input leads is driven negative. It is due to the collector-base junction of the input PNP transistor becoming forward biased and thereby acting as input diodes clamps. In addition to this diode action, there is also NPN parasitic action on the IC chip. this transistor action can cause the output voltages of the Op-amps to go to the V_{CC} voltage level (or to ground for a large overdrive) for the time duration than an input is driven negative. This is not destructive and normal output will set up again for input voltage higher than -0.3V.

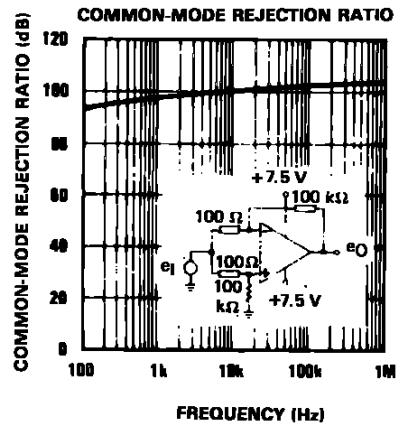
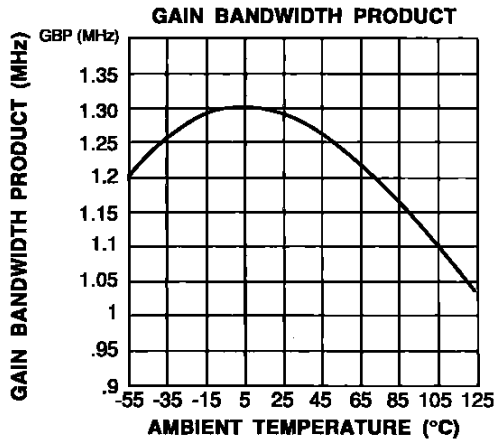
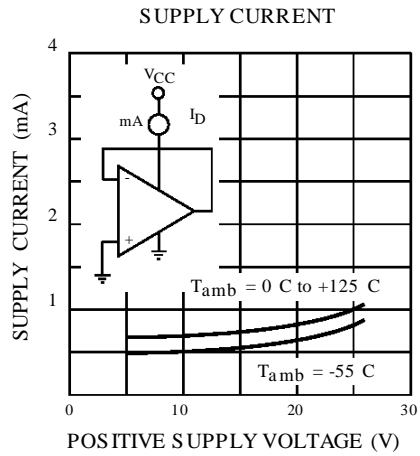
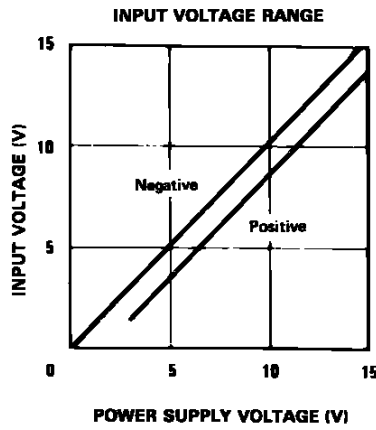
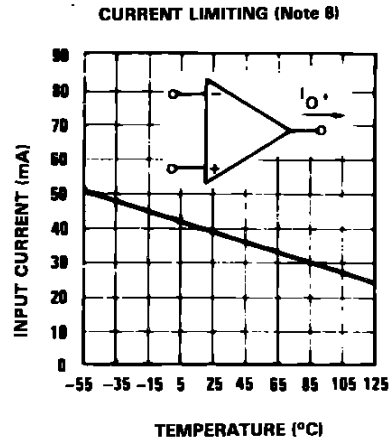
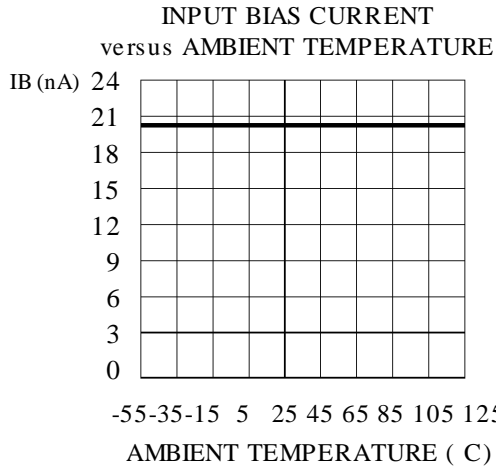

OPEN LOOP FREQUENCY RESPONSE

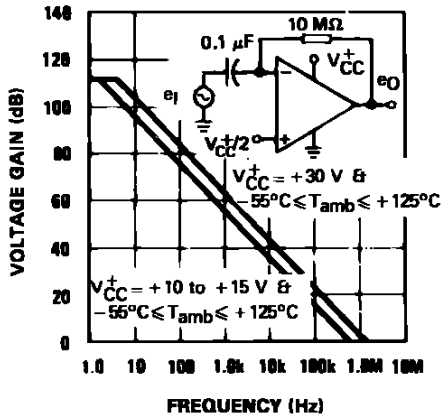

LARGE SIGNAL FREQUENCY RESPONSE

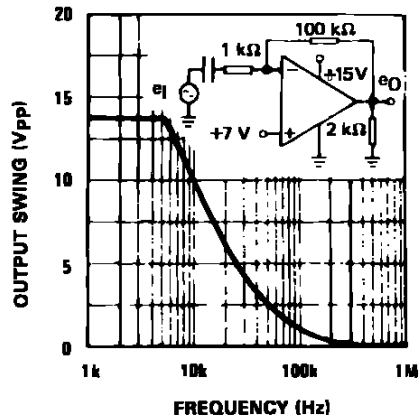

VOLTAGE FOLLOWER PULSE RESPONSE

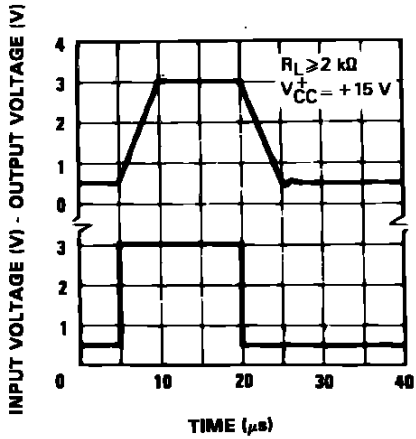

OUTPUT CHARACTERISTICS (CURRENT SINKING)

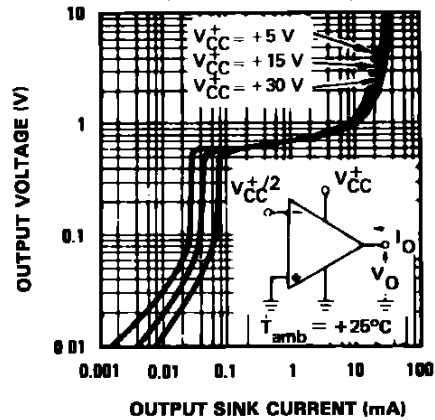

VOLTAGE FOLLOWER PULSE RESPONSE (SMALL SIGNAL)

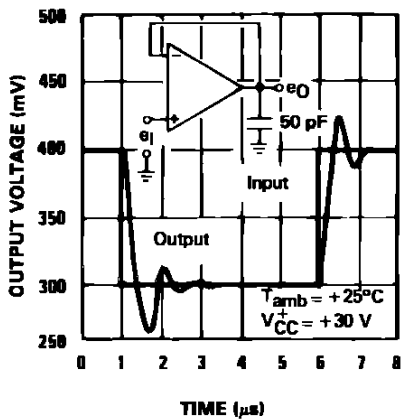

OUTPUT CHARACTERISTICS (CURRENT SOURCING)

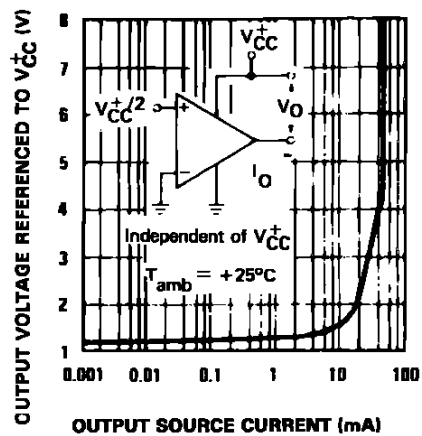

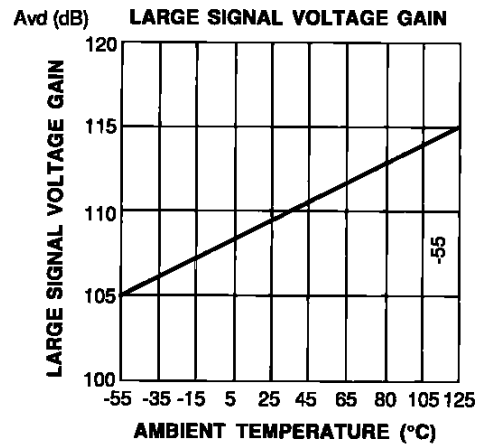
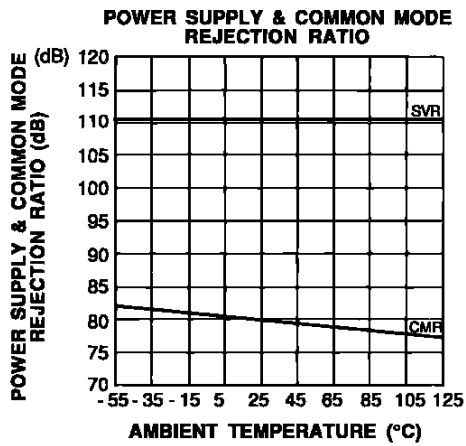
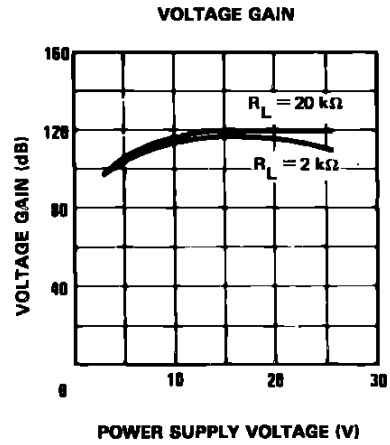
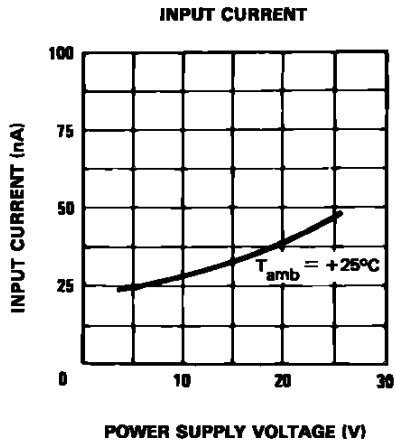

TYPICAL SINGLE - SUPPLY APPLICATIONS

AC COUPLED INVERTING AMPLIFIER

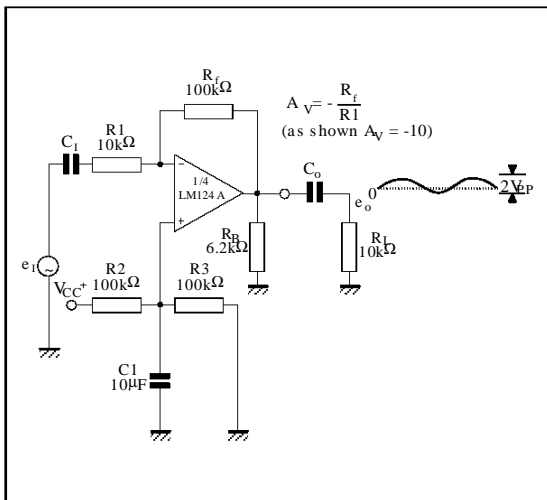

AC COUPLED NON-INVERTING AMPLIFIER

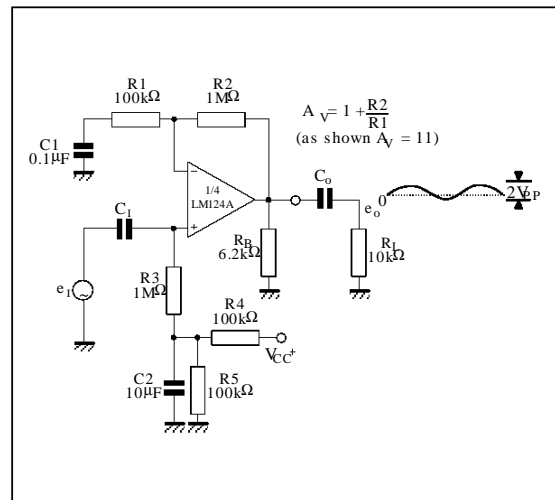

TYPICAL SINGLE - SUPPLY APPLICATIONS

NON-INVERTING DC GAIN

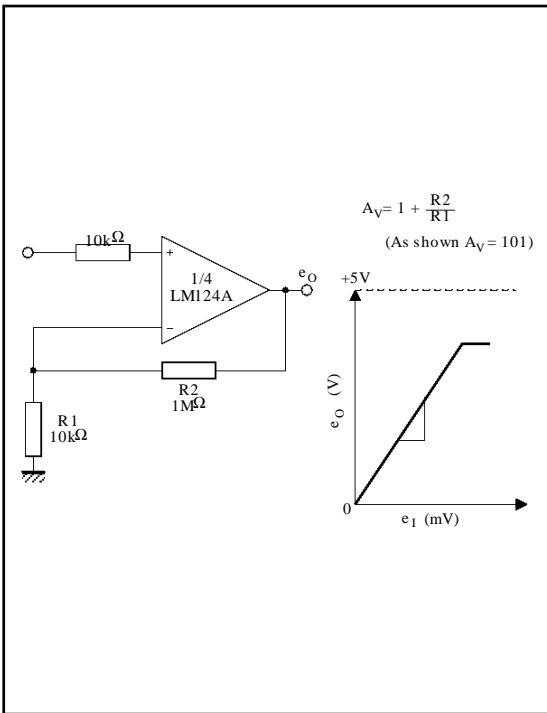

DC SUMMING AMPLIFIER

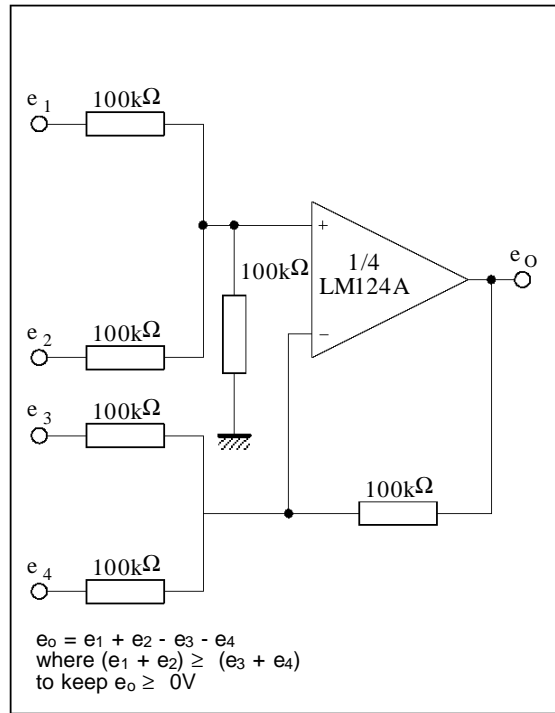

HIGH INPUT Z ADJUSTABLE GAIN DC INSTRUMENTATION AMPLIFIER

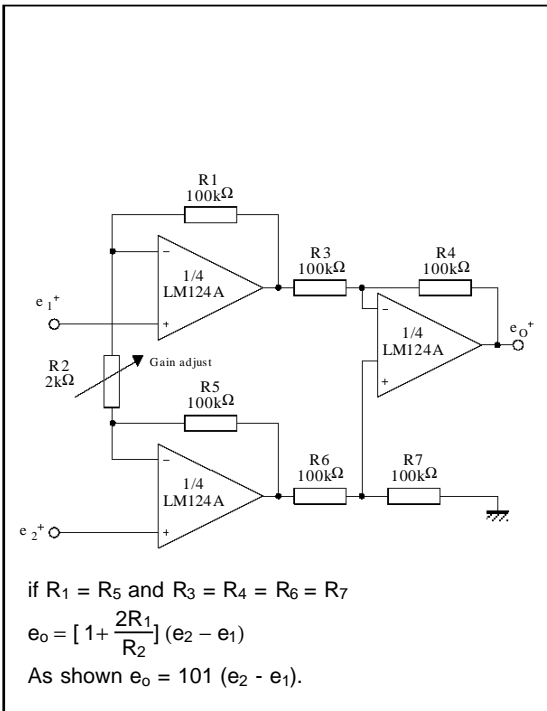

LOW DRIFT PEAK DETECTOR

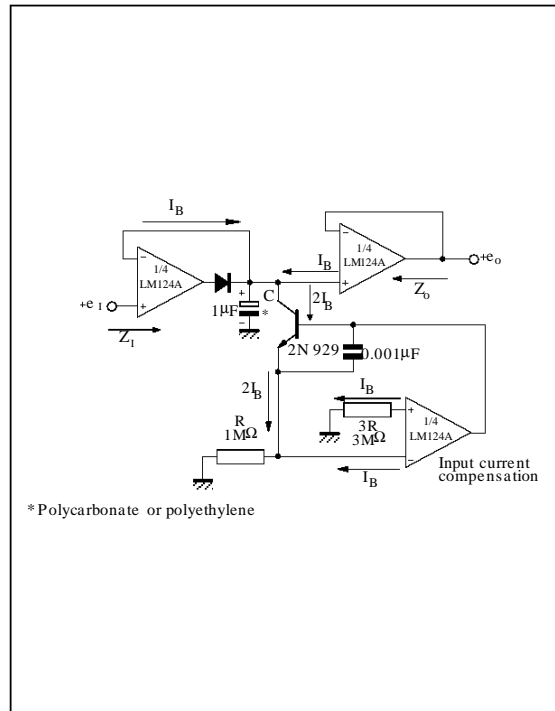

TYPICAL SINGLE - SUPPLY APPLICATIONS

ACTIVER BANDPASS FILTER

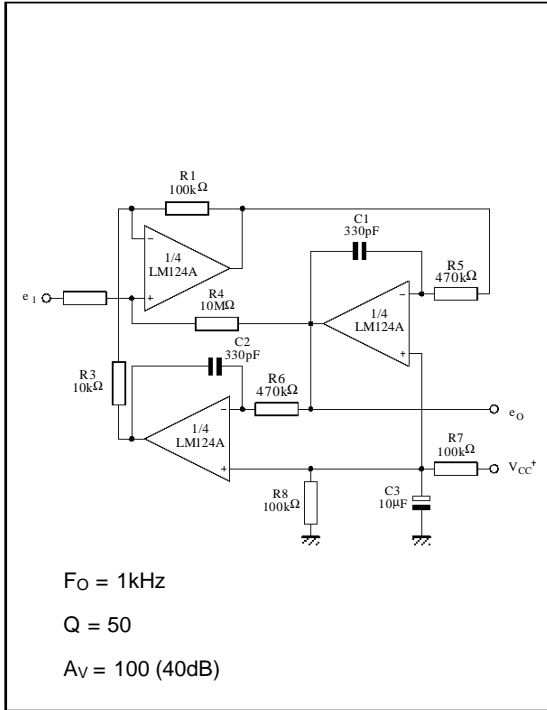

HIGH INPUT Z, DC DIFFERENTIAL AMPLIFIER

For $\frac{R_1}{R_2} = \frac{R_4}{R_3}$
 (CMRR depends on this resistor ratio match)

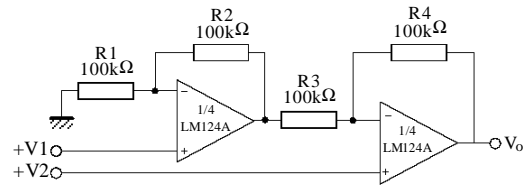

$e_o (1 + \frac{R_4}{R_3}) (e_2 - e_1)$
 As shown $e_o = (e_2 - e_1)$

USING SYMMETRICAL AMPLIFIERS TO REDUCE INPUT CURRENT (GENERAL CONCEPT)

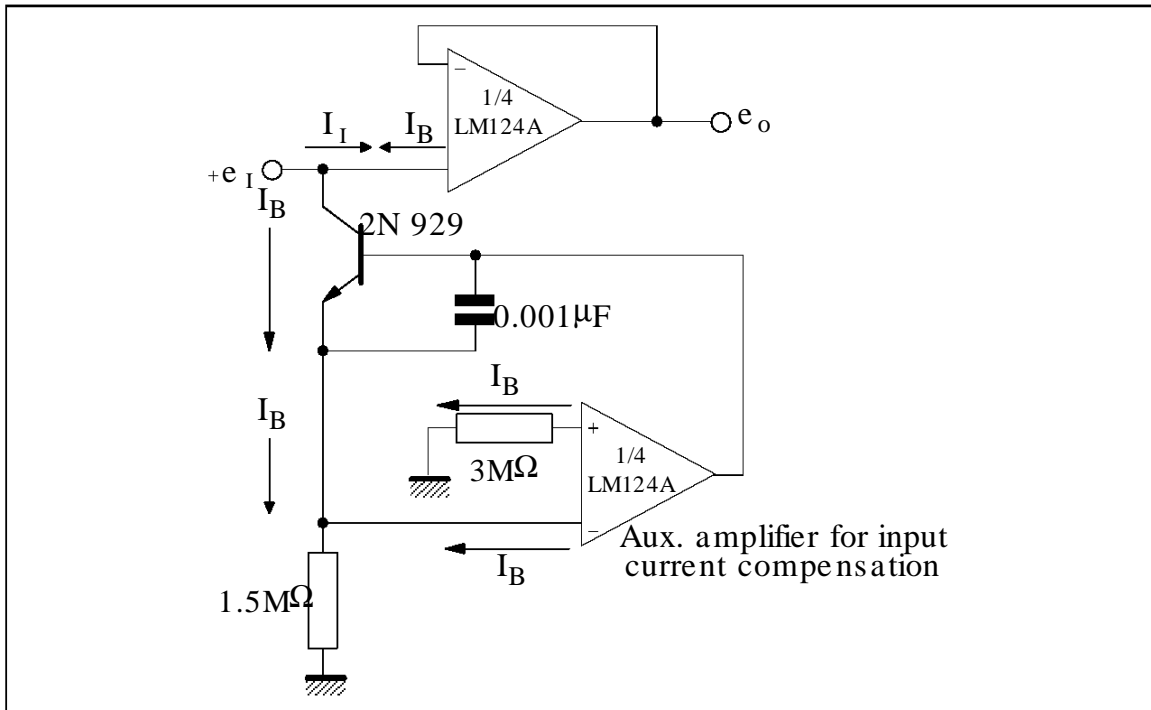

LM124A - LM224A - LM324A

- LARGE VOLTAGE GAIN : 100dB
- VERY LOW SUPPLY CURRENT/AMPLI : 375µA
- LOW INPUT BIAS CURRENT : 20nA
- LOW INPUT OFFSET VOLTAGE : 2mV
- LOW INPUT OFFSET CURRENT : 2nA
- WIDE POWER SUPPLY RANGE :
SINGLE SUPPLY : +3V to +30V
DUAL SUPPLIES : ±1.5V to ±15V

Applies to : LM124A-LM224A-LM324A

** Standard Linear Ics Macromodels, 1993.

** CONNECTIONS :

* 1 INVERTING INPUT

* 2 NON-INVERTING INPUT

* 3 OUTPUT

* 4 POSITIVE POWER SUPPLY

* 5 NEGATIVE POWER SUPPLY

.SUBCKT LM124 1 3 2 4 5 (analog)

.MODEL MDTH D IS=1E-8 KF=3.104131E-15
CJO=10F

* INPUT STAGE

CIP 2 5 1.000000E-12

CIN 1 5 1.000000E-12

EIP 10 5 2 5 1

EIN 16 5 1 5 1

RIP 10 11 2.600000E+01

RIN 15 16 2.600000E+01

RIS 11 15 2.003862E+02

DIP 11 12 MDTH 400E-12

DIN 15 14 MDTH 400E-12

VOFP 12 13 DC 0

VOFN 13 14 DC 0

IPOL 13 5 1.000000E-05

CPS 11 15 3.783376E-09

DINN 17 13 MDTH 400E-12

VIN 17 5 0.000000E+00

DINR 15 18 MDTH 400E-12

VIP 4 18 2.000000E+00

FCP 4 5 VOFP 3.400000E+01

FCN 5 4 VOFN 3.400000E+01

FIBP 2 5 VOFN 2.000000E-03

FIBN 5 1 VOFP 2.000000E-03

* AMPLIFYING STAGE

FIP 5 19 VOFP 3.600000E+02

FIN 5 19 VOFN 3.600000E+02

RG1 19 5 3.652997E+06

RG2 19 4 3.652997E+06

CC 19 5 6.000000E-09

DOPM 19 22 MDTH 400E-12

DONM 21 19 MDTH 400E-12

HOPM 22 28 VOUT 7.500000E+03

VIPM 28 4 1.500000E+02

HONM 21 27 VOUT 7.500000E+03

VINM 5 27 1.500000E+02

EOUT 26 23 19 5 1

VOUT 23 5 0

ROUT 26 3 20

COUT 3 5 1.000000E-12

DOP 19 25 MDTH 400E-12

VOP 4 25 2.242230E+00

DON 24 19 MDTH 400E-12

VON 24 5 7.922301E-01

.ENDS

ELECTRICAL CHARACTERISTICS $V_{CC}^+ = +5V$, $V_{CC}^- = 0V$, $T_{amb} = 25^{\circ}C$ (unless otherwise specified)

Symbol	Conditions	Value	Unit
V_{io}		0	mV
A_{vd}	$R_L = 2k\Omega$	100	V/mV
I_{CC}	No load, per operator	350	μA
V_{icm}		-15 to +13.5	V
V_{OH}	$R_L = 2k\Omega$ ($V_{CC}^+ = 15V$)	+13.5	V
V_{OL}	$R_L = 10k\Omega$	5	mV
I_{OS}	$V_O = +2V$, $V_{CC} = +15V$	+40	mA
GBP	$R_L = 2k\Omega$, $C_L = 100pF$	1.3	MHz
SR	$R_L = 2k\Omega$, $C_L = 100pF$	0.4	V/ μs

LM124A - LM224A - LM324A

PACKAGE MECHANICAL DATA 14 PINS - PLASTIC DIP

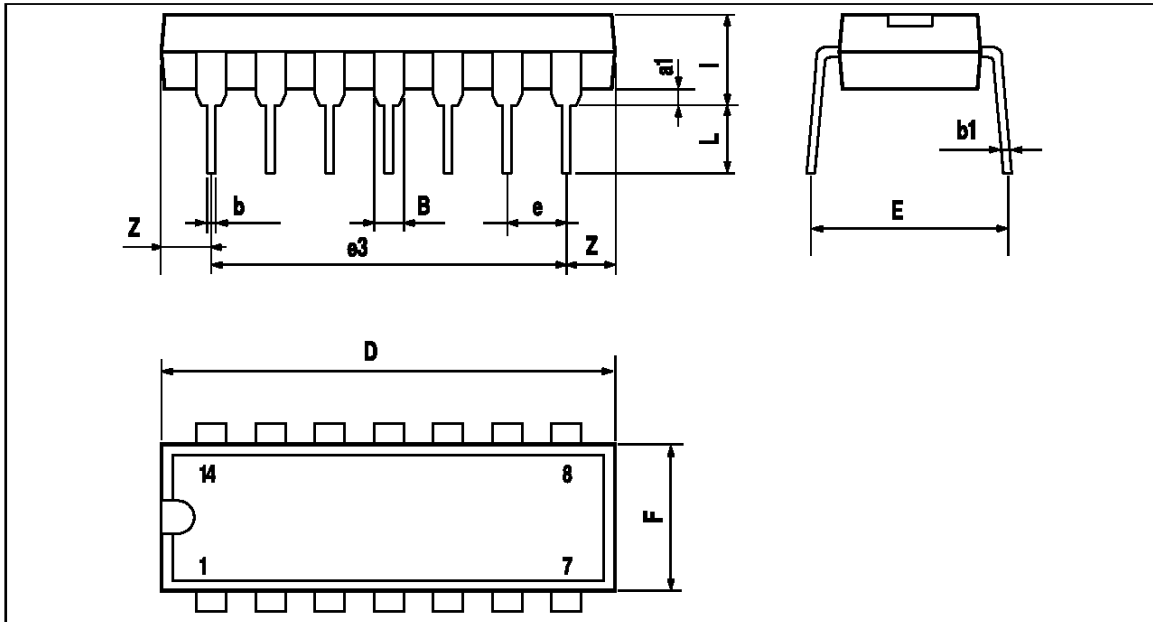

PM-DIP14.EPS

Dimensions	Millimeters			Inches		
	Min.	Typ.	Max.	Min.	Typ.	Max.
a1	0.51			0.020		
B	1.39		1.65	0.055		0.065
b		0.5			0.020	
b1		0.25			0.010	
D			20			0.787
E		8.5			0.335	
e		2.54			0.100	
e3		15.24			0.600	
F			7.1			0.280
i			5.1			0.201
L		3.3			0.130	
Z	1.27		2.54	0.050		0.100

DIP14.TBL

PACKAGE MECHANICAL DATA
14 PINS - PLASTIC MICROPACKAGE (SO)

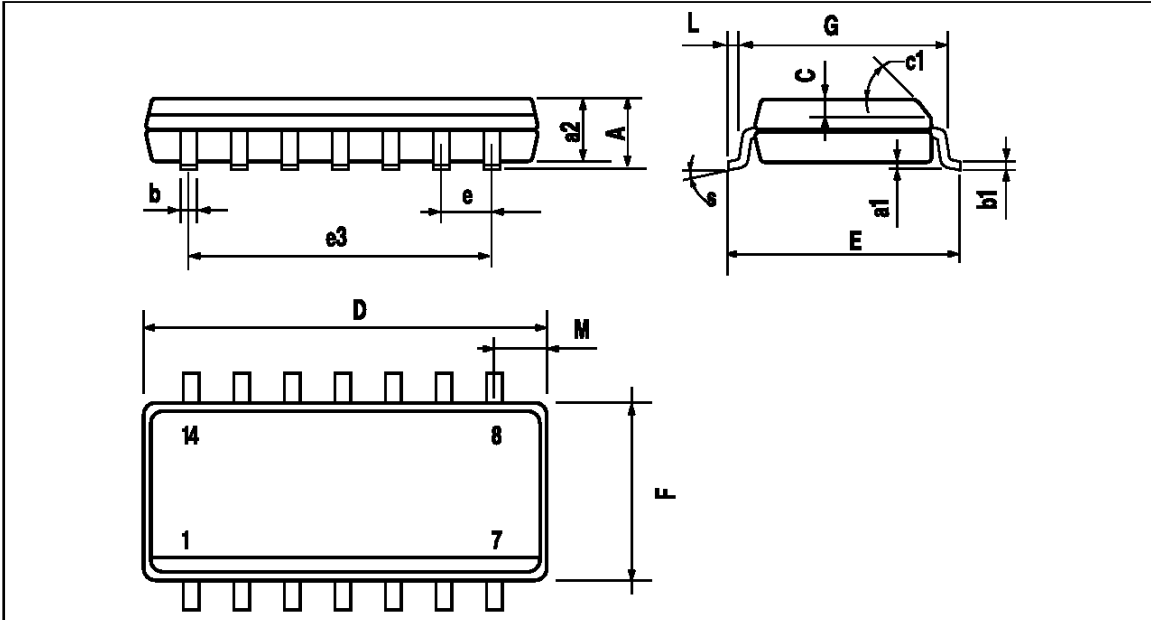

PM-SO14.EPS

Dimensions	Millimeters			Inches		
	Min.	Typ.	Max.	Min.	Typ.	Max.
A			1.75			0.069
a1	0.1		0.2	0.004		0.008
a2			1.6			0.063
b	0.35		0.46	0.014		0.018
b1	0.19		0.25	0.007		0.010
C		0.5			0.020	
c1	45° (typ.)					
D	8.55		8.75	0.336		0.334
E	5.8		6.2	0.228		0.244
e		1.27			0.050	
e3		7.62			0.300	
F	3.8		4.0	0.150		0.157
G	4.6		5.3	0.181		0.208
L	0.5		1.27	0.020		0.050
M			0.68			0.027
S	8° (max.)					

SO14.TBL

Information furnished is believed to be accurate and reliable. However, SGS-THOMSON Microelectronics assumes no responsibility for the consequences of use of such information nor for any infringement of patents or other rights of third parties which may result from its use. No license is granted by implication or otherwise under any patent or patent rights of SGS-THOMSON Microelectronics. Specifications mentioned in this publication are subject to change without notice. This publication supersedes and replaces all information previously supplied. SGS-THOMSON Microelectronics products are not authorized for use as critical components in life support devices or systems without express written approval of SGS-THOMSON Microelectronics.

© 1997 SGS-THOMSON Microelectronics – Printed in Italy – All Rights Reserved

SGS-THOMSON Microelectronics GROUP OF COMPANIES
Australia - Brazil - Canada - China - France - Germany - Hong Kong - Italy - Japan - Korea - Malaysia - Malta - Morocco
The Netherlands - Singapore - Spain - Sweden - Switzerland - Taiwan - Thailand - United Kingdom - U.S.A.

ORDER CODE :