

HANDSFREE CONTROLLER

PRELIMINARY DATA

- NOISE/SPEECH DISCRIMINATION IN EMISSION AND RECEPTION
- INTEGRATED SIGNAL GAIN COMPRESSOR IN BOTH MODES
- PROGRAMMABLE ATTENUATORS IN BOTH MODES
- ADAPTED TO ACOUSTIC PARAMETERS OF ALL CABINETS
- LOW OPERATING VOLTAGE 2.5V
- LOW OPERATING CURRENT 2.1mA
- CHIP SELECT BETWEEN HANDSFREE AND MONITORING MODES

DESCRIPTION

This 28 pins IC is an innovative approach to quality handsfree telephone sets. It results from an extensive research on speech signal.

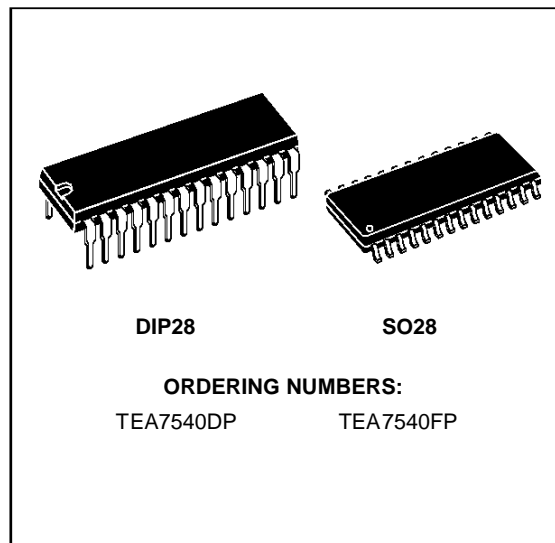

PIN CONNECTION (top view)

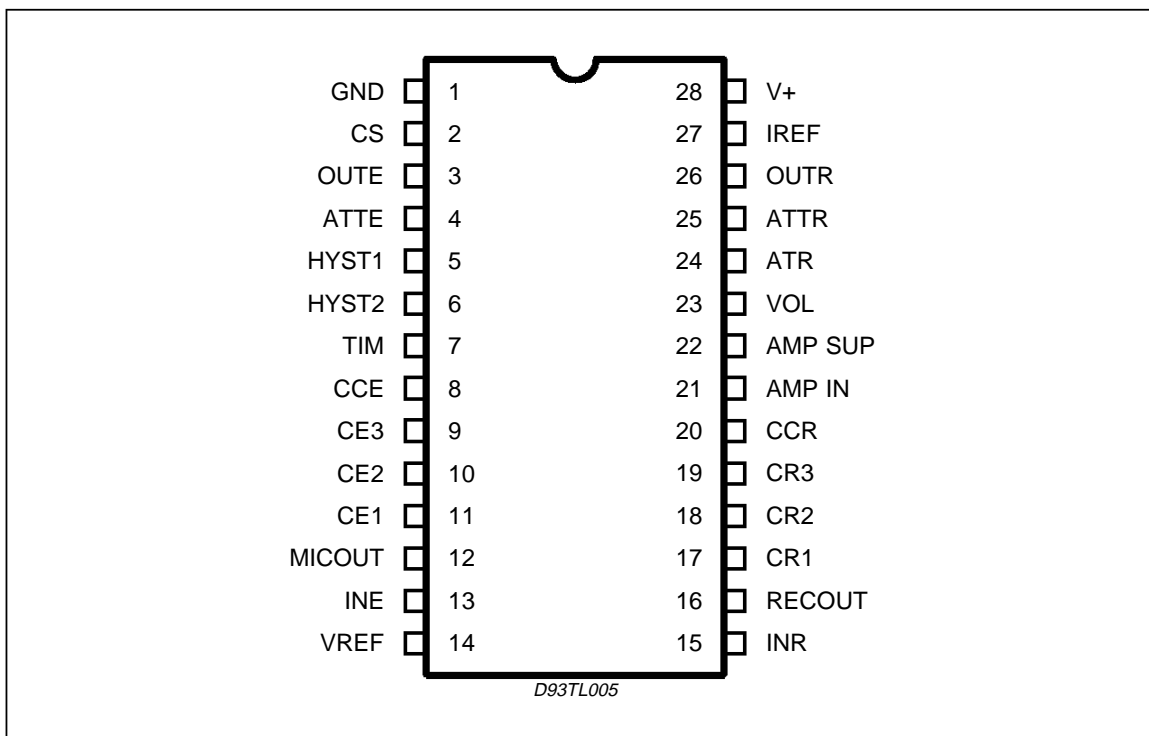

BLOCK DIAGRAM

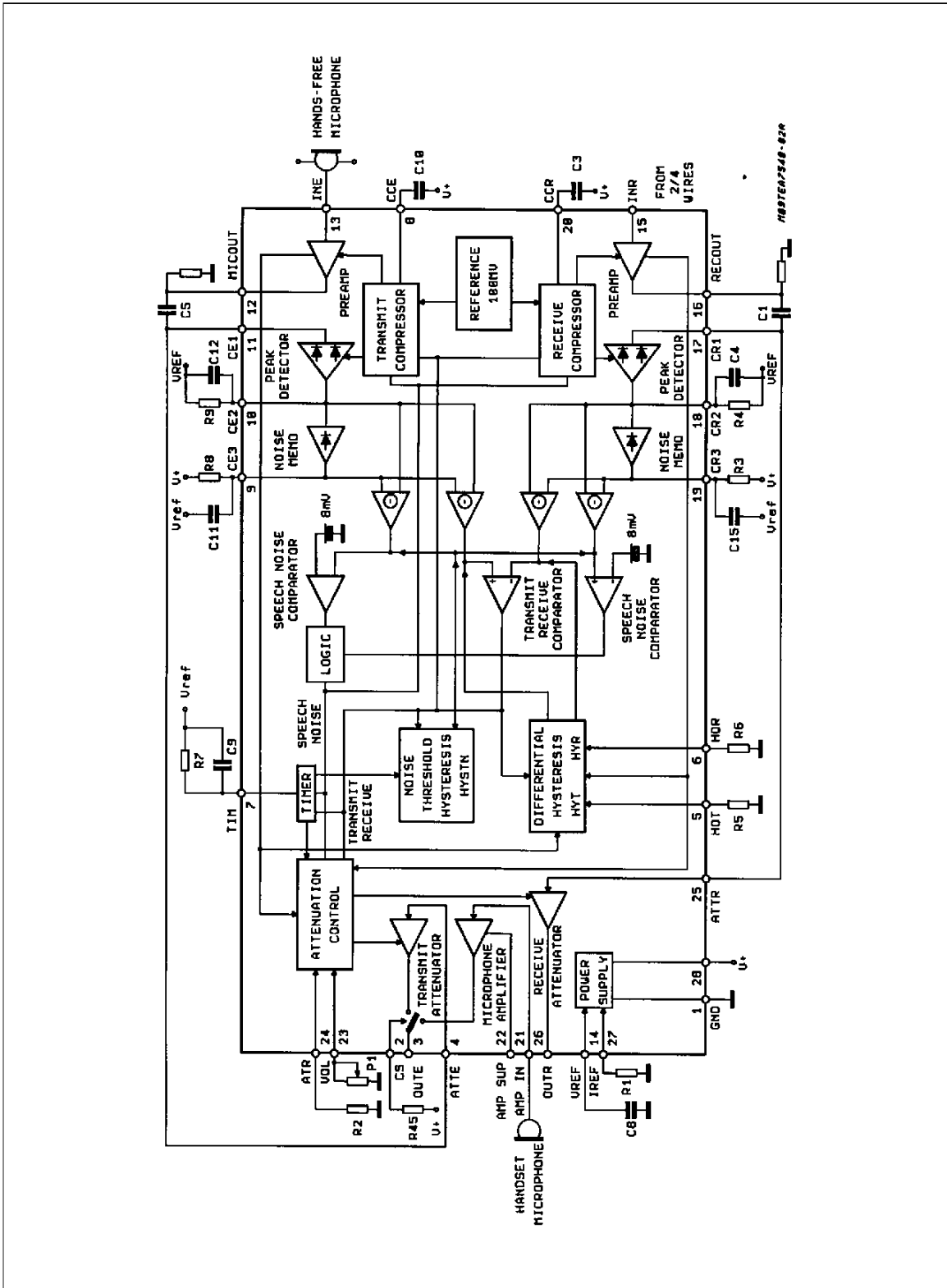

PIN FUNCTION

N°	Name	Function
1	GND	Ground
2	CS	Chip Select
3	OUTE	Transmit Attenuator Output
4	ATTE	Transmit Attenuator Input
5	HYST1	Transmit Channel Hysteresis
6	HYST2	Receive Channel Hysteresis
7	TIM	RC Timer
8	CCE	Time Constant of the Transmit Signal Compressor
9	CE3	Transmit Background Noise Memorization Output
10	CE2	Transmit Peak Detector Output
11	CE1	Transmit Rectifier Input
12	MICOUT	Transmit Signal Compressor Output
13	INE	Transmit Signal Compressor Input
14	V _{ref}	V+/2 - Reference Voltage
15	INR	Receive Signal Compressor Input
16	RECOU	Receive Signal Compressor Output
17	CR1	Receive Rectifier Input
18	CR2	Receive Peak Detector Output
19	CR3	Receive Background Noise Memorization Output
20	CCR	Time Constant of the Receive Signal Compressor
21	AMP IN	Handset Preamplifier Input
22	AMP SUP	Handset Preamplifier Power Supply
23	VOL	Volume Control
24	ATR	Attenuation Value
25	ATTR	Receive Attenuator Input
26	OUTR	Receive Attenuator Output
27	I _{ref}	Reference Current Source
28	V+	

FUNCTIONAL DESCRIPTION**SWITCHED ATTENUATORS**

Fig.A represents a block diagram of a handsfree subset with attenuators in signal mode. To prevent the system from howling, the total loop gain, including acoustic feedback through the housing and sidetone coupling, must be less than 0dB. For this purpose, two switched attenuators are inserted in each mode (emission and reception). The attenuation is shifted from one mode to the other, resulting from the speech level comparison between each way.

To prevent the circuit to switch continuously in one way, the operation of the IC must be fully symmetrical in both ways. This involves signal comparison, attenuation value.

GAIN COMPRESSOR

In TEA7540, two signal compressors are inserted in each mode before the signal comparison, so

the signal coming from each end has the same level (100mV peak), the losses in each way (for instance losses resulting from the line length in receiving mode) are compensated and the signal comparison is fully symmetrical. The time constant of each signal compressor decreases 80 times more quickly than it increases to prevent from noise increasing between words. The compressing depth is 38dB.

BACKGROUND NOISE DISCRIMINATION

An additional feature provided in TEA7540 is background noise level discrimination in each way. The IC stores the background sound level with a long time constant (3 to 5 seconds depending on an external RC) and compares it with the incoming signal in order to distinguish a useful signal (speech) from the background noise. This background noise memorization is also used to compensate the noise in each mode before signal comparison: the noise level in each mode is sub-

TEA7540

strated from the incoming signal before the comparison. So very high noise level in one mode cannot trouble the comparison between the useful signals.

The result of the comparison manages the attenuators in the following way:

- The maximum attenuation is switched on the mode where the speech signal is the lowest. The maximum attenuation is fixed by two external resistor (maximum 52dB).

The time constant of the switch is fixed by the timer via an external capacitor.

- When neither party is talking both attenuators are set to a medium attenuation. Thus each mode is in idle mode. The time constant of the switch from active mode to idle mode must be long enough to prevent from switching to idle mode between two words (see fig.B). This time constant is fixed by an external RC.

Figure A

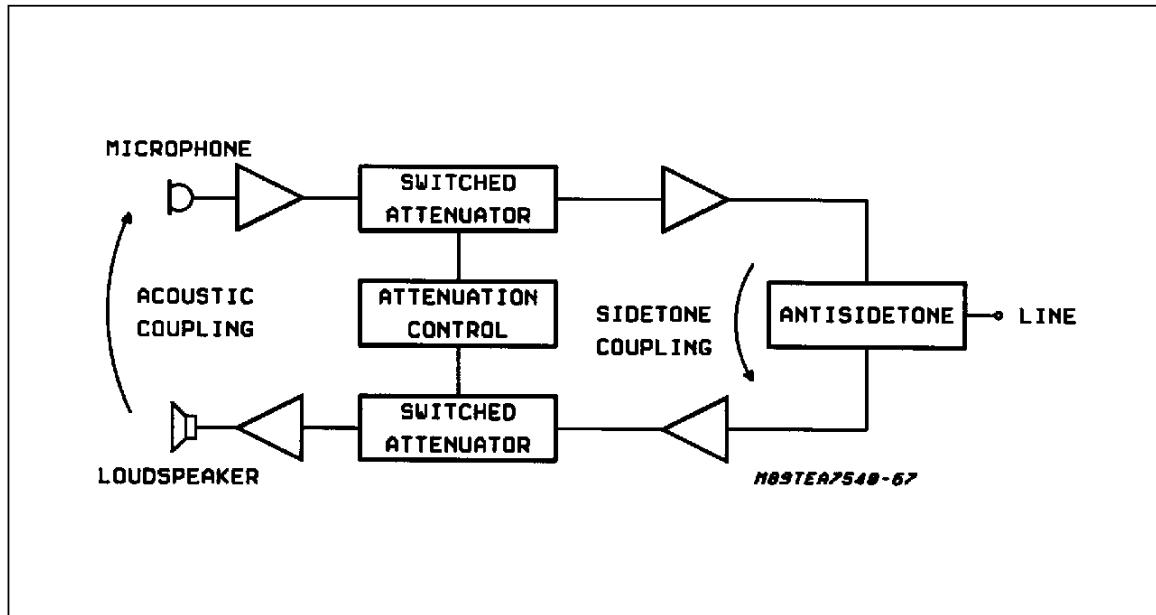
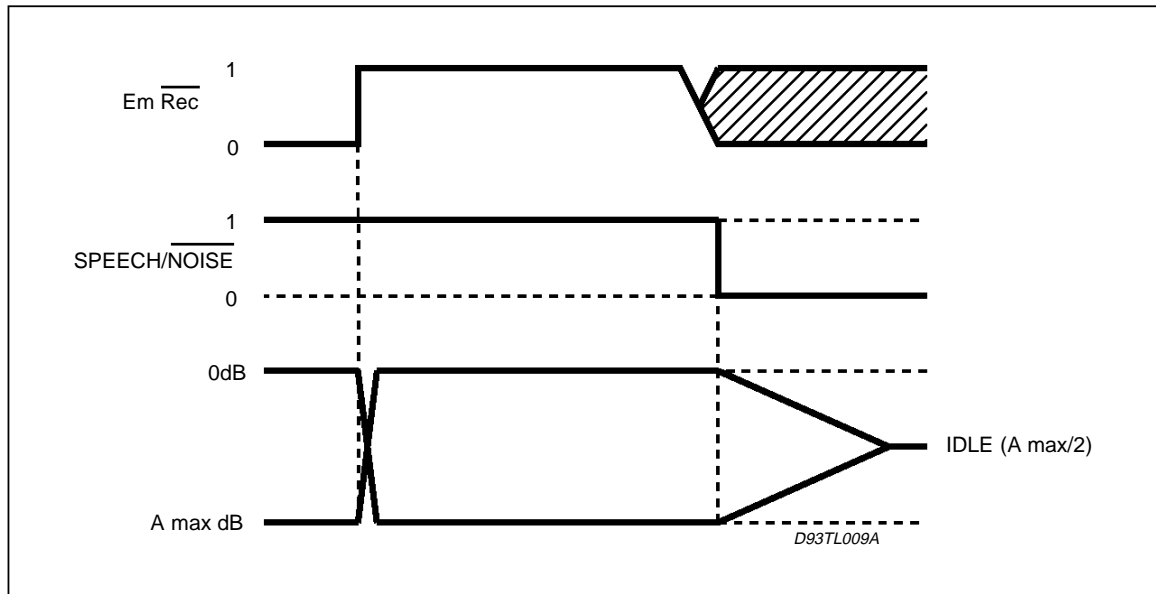

Figure B



TEA7540 OPERATION

TEA7540 is powered through an external shunt regulator (for instance the shunt regulator of the monitor amplifier TEA7532) or an external zener diode.

It can work at a very low voltage (2.5V) over the circuit and it has a low current consumption (2.1mA).

It's also possible via the chip select pin (CS) to

put the handsfree function in standby to use the circuit in monitoring mode with the handset microphone.

TEA7540 is designed to work with all kind of microphone, including Electret.

TEA7540 also handles the handset microphone signal (AMP IN) when the system is set to normal conversation mode.

Figure C: Application Diagram (Example of high range telephone set using TEA7540).

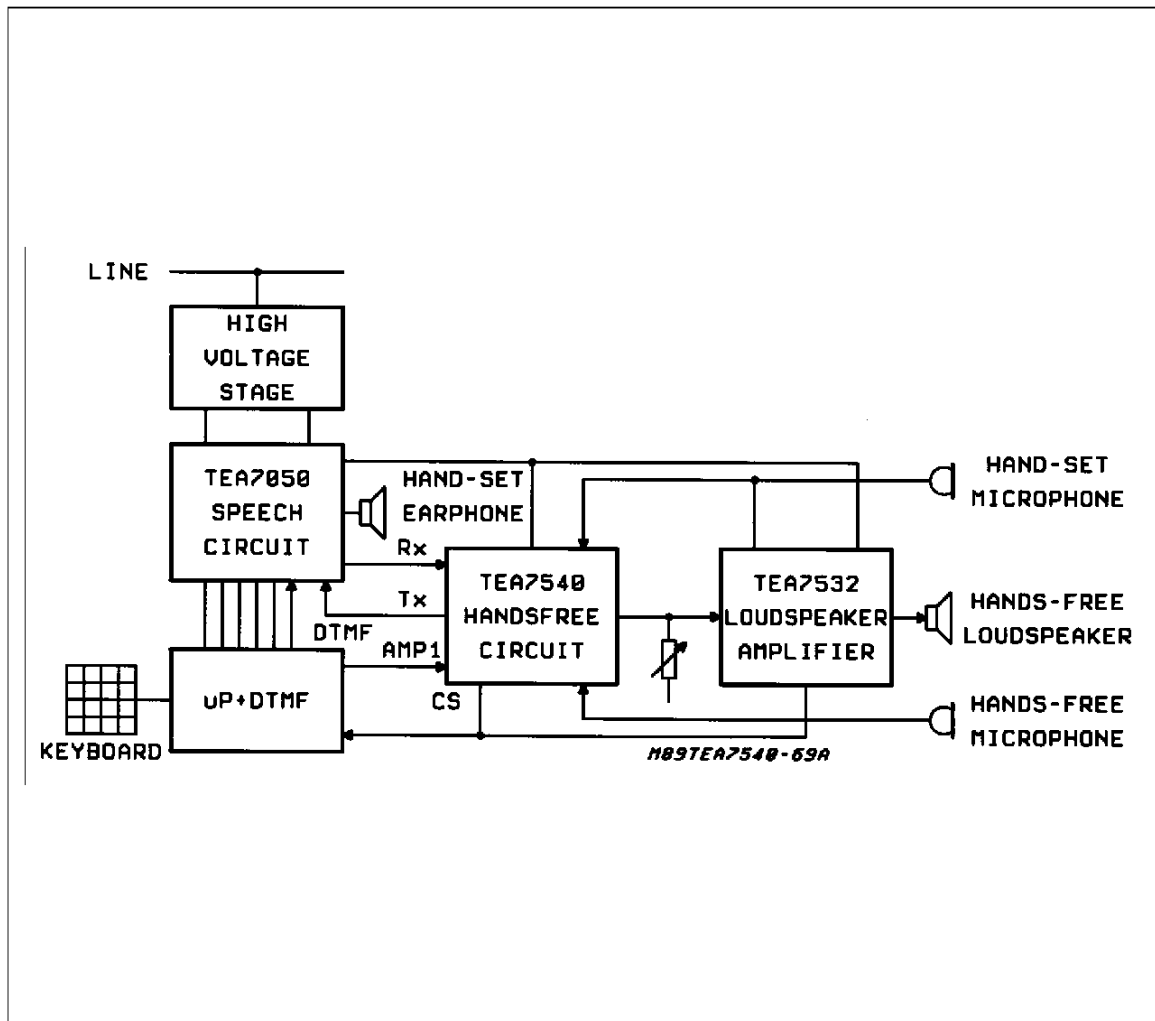
**ABSOLUTE MAXIMUM RATINGS**

Symbol	Parameter	Value	Unit
V ⁺	Supply Voltage	12	V
T _{op}	Operating Temperature	-20 to 70	°C
T _{stg}	Storage Temperature Range	-65 to 125	°C

TEA7540

ELECTRICAL CHARACTERISTICS (Refer to test circuits, $T_{amb} = 25^{\circ}\text{C}$; $V^{\dagger} = 3\text{V}$; $f = 1\text{KHz}$ unless otherwise specified).

Symbol	Parameter	Test Condition	Min.	Typ.	Max.	Unit	Fig.
--------	-----------	----------------	------	------	------	------	------

SUPPLY SECTION

V^{\dagger}	Supply Voltage		2.5		7.0	V	1
I_C	Current Consumption	$V_{cs} = 0$ Handsfree mode $V_{cs} = \text{N.C.}$ Monitoring mode		2.1	3.0	mA	1
				1.1	1.5	mA	

TRANSMIT SECTION

COMPRESSOR

R_{ine}	Compressor input impedance	PIN13	7.5	10.0	14.5	K Ω	1
C_R	Compressor Range			16.5		dB	
G_{1max}	Maximum Gain		40.5	41.5	42.5	dB	2
G_{1min}	Minimum Gain		24.0	25.0	26.0	dB	3
V_O	Output Voltage	PIN12 compressing range	160	200	240	mVpp	4
T_{dh}	Transmit Distortion				3.0	%	4
I_{cce1}	Compressor decay time current	Increasing gain	1.0	1.25	1.5	μA	5
I_{cce2}	Compressor rise time current	Decreasing gain	65	85	105	μA	6
V_{cce1}	Voltage drop PIN8	G_{1max}		0	20	mV	2
V_{cce2}	$V_{cce} = V_{ref} - V_{pin8}$	G_{1min}	175	225	275	mV	3

PEAK DETECTOR

$R_{inp d}$	Input impedance PIN11		7.5	10.0	14.5	K Ω	1
I_{ce2}	Rise time current		16	20	24	μA	7

NOISE MEMORIZATION

V_1	Max voltage drop on pin 9		33	36	45	mV	8
-------	---------------------------	--	----	----	----	----	---

ATTENUATOR

R_{ina}	Input impedance PIN4		7.5	10	14.5	K Ω	1
ATE-	Attenuation= $20\log(V_{oute}/V_{atte})$ Mode: Inactive Tx, Rx Comp. Max Gain	$R_{pin24} = 11\text{K}\Omega$ $R_{pin24} = 15\text{K}\Omega$		46 58		dB dB	9
ATE-active	Mode: Active	$R_{pin24} = 11\text{K}\Omega$	0	1.5	3	dB	10
ATE-IDLE	Mode: Noise Tx, Rx Comp. Max Gain	$R_{pin24} = 11\text{K}\Omega$		23		dB	11

RECEIVE SECTION

COMPRESSOR

R_{inr}	Input impedance	PIN15	7.5	10.0	14.5	K Ω	1
C_R	Compressor Range			20.5		dB	
G_{2max}	Maximum Gain		35.5	36.5	37.5	dB	2
G_{2min}	Minimum Gain		15.0	16.0	17.0	dB	3
V_{micout}	Compressor output voltage	PIN16 compressing range	160	200	240	mVpp	4
R_{dh}	Receive Distortion				3.0	%	4
I_{ccr1}	Compressor decay time current	Increasing gain	1.0	1.25	1.5	μA	5
I_{ccr2}	Compressor rise time current	Decreasing gain	65	85	105	μA	6
V_{ccr1}	Voltage drop PIN20	G_{2max}		0	20	mV	2
V_{ccr2}	$V_{ccr} = V_{ref} - V_{pin20}$	G_{2min}	175	225	275	mV	3
Symbol	Parameter	Test Condition	Min.	Typ.	Max.	Unit	Fig.

ELECTRICAL CHARACTERISTICS (continued)

PEAK DETECTOR

R_{inpd}	Input impedance	PIN17	7.5	10	14.5	K Ω	1
I_{cr2}	Rise time current		16	20	24	μ A	7

NOISE MEMORIZATION

V1	Max voltage drop on PIN 19		33	36	45	mV	8
----	----------------------------	--	----	----	----	----	---

ATTENUATOR

Rina	Input impedance	PIN25	7.5	10	14.5	K Ω	1
ATR-	Attenuation= $20\lg(V_{outr}/V_{atte})$ Mode: Inactive RX, TX Comp. Max Gain	Rpin24 = 11K Ω Rpin24 = 15K Ω		46 58		dB dB	9
ATR-active	Mode: Active	Rpin24 = 11K Ω	0	1.5	3	dB	10
ATR-IDLE	Mode: Noise RX, TX Comp. Max Gain	Rpin24 = 11K Ω		23		dB	11

ATTENUATION CONTROL SECTION

V_{TIME}	Tx Mode Att.Voltage		190	250	325	mV	12
I_{TIME}	TX Mode Att.Current		40	50	70	μ A	12
V_{TIMR}	RX Mode Att.Voltage		-325	-250	-190	mV	13
I_{TIMR}	RX Mode Att.Current		40	50	70	μ A	13
ATRVOL	Volume Control		29	32	35	dB	14

MICROPHONE PREAMPLIFIER

R_{amp}	Imput impedance	PIN21	35	50	70	K Ω	
G_{mic}	$V_{mic} = V_{oute} - V_{amp\ in}$	V_{cs} open	19	20	21	dB	
G_{2off}	Compressor Gain Monitoring Mode $G2 = V_{recout}/V_{inr}$	Rext between PINs 2 - 28 Rext = open Rext = 40K Ω		36.5 16		dB dB	

Figure 1: Basic Configuration

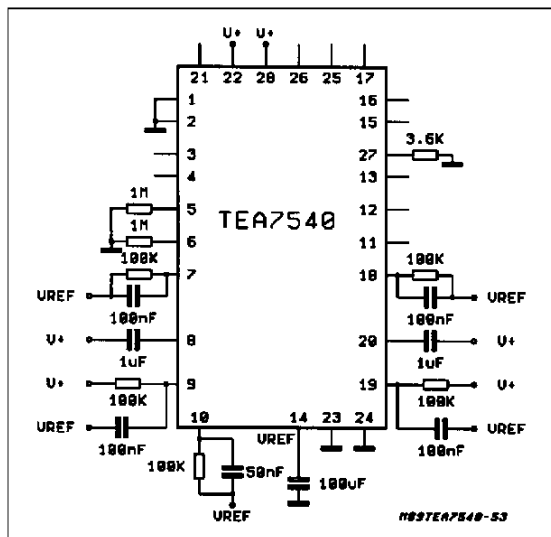
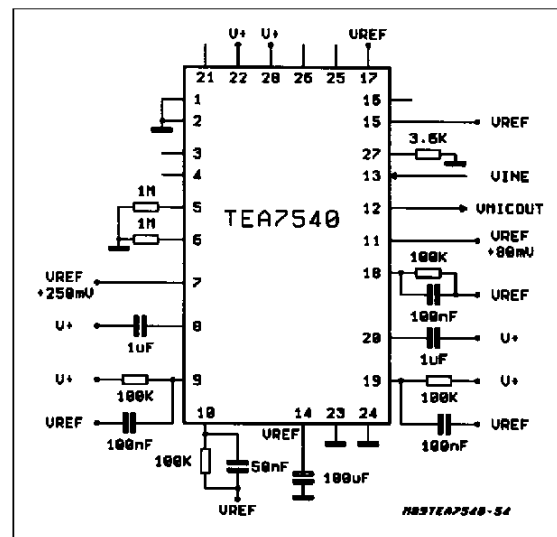

Figure 2: Test Configuration

V⁺ = 3V

pin 7 is forced to transmit mode

pin 11 is forced to max gain

Input signal on pin 13 V_{INE} = 1.5mV_{pp}output voltage V_{MICOUT} measured on pin 12 $G1_{max} = 20\lg(V_{MICOUT} / V_{INE})$

TEA7540

Figure 3: Test Configuration

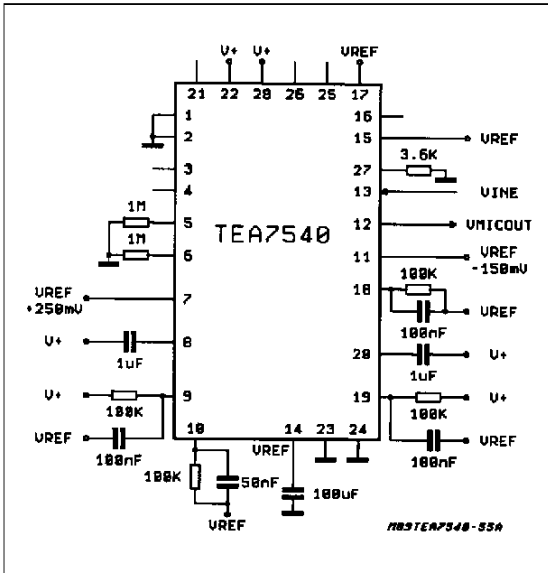

$V^+ = 3V$
 pin 7 is forced to transmit mode
 pin 11 is forced to minimum gain
 Input signal on pin 13 VINE = 1.5mVpp
 output voltage VMICOUT measured on pin 12

$$G1min = 20\log (VMICOUT / VINE)$$

Figure 4: Test Configuration

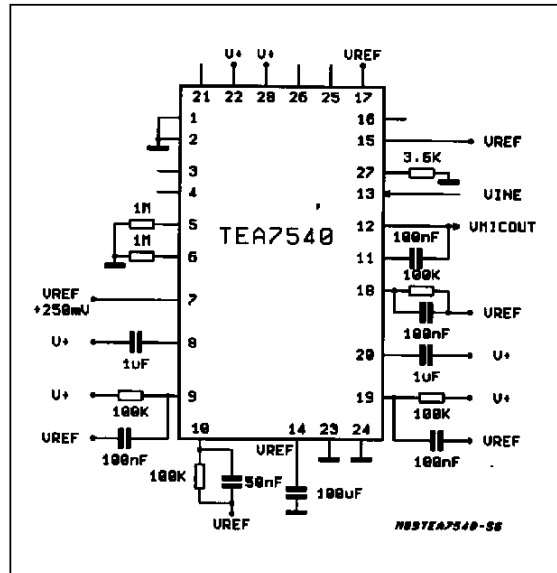

$V^+ = 3V$
 pin 7 is forced to transmit mode
 Input signal on pin 13 VINE in the compressing range (5mVpp for example)
 output voltage VMICOUT measured on pin 12

Figure 5: Test Configuration

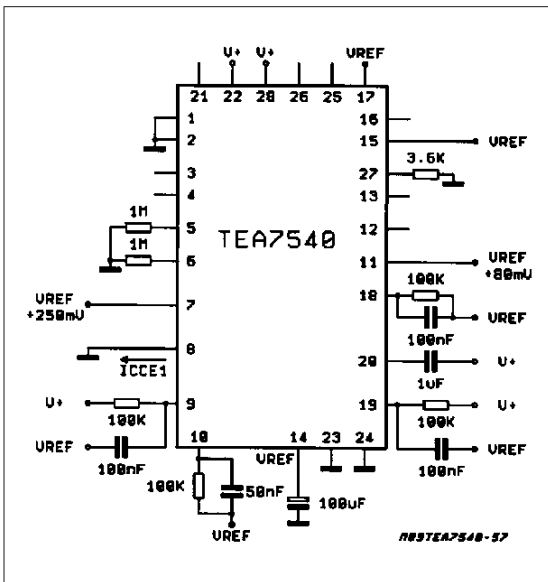

$V^+ = 3V$
 pin 7 is forced to transmit mode
 pin 11 is forced to maximum gain

Figure 6: Test Configuration

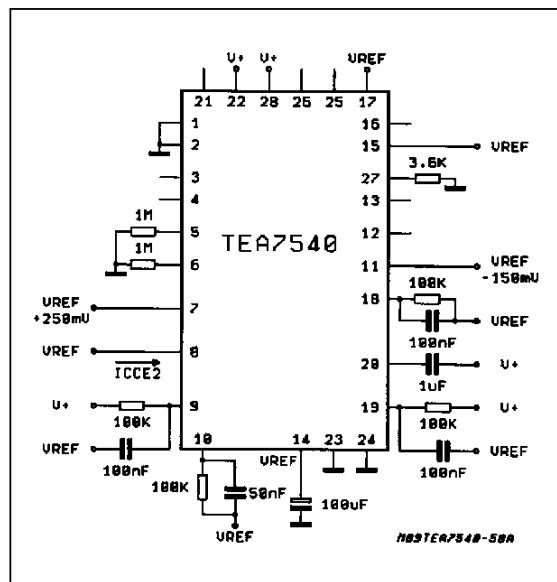

$V^+ = 3V$
 pin 7 is forced to transmit mode
 pin 11 is forced to minimum gain

Figure 7: Test Configuration

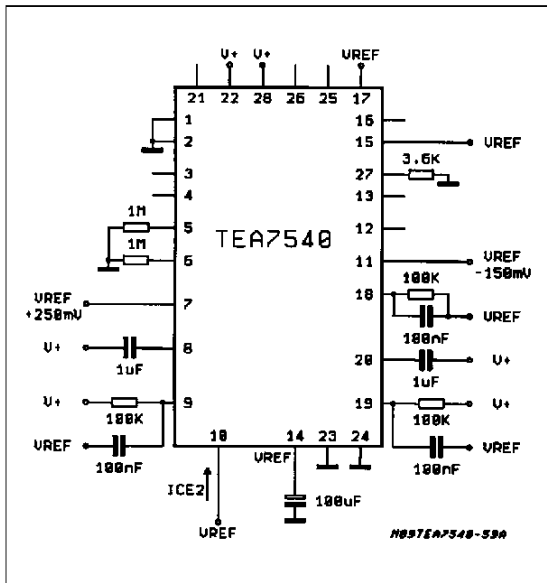

$V^+ = 3V$
pin 7 is forced to transmit mode
pin 11 is forced to minimum gain

Figure 8: Test Configuration

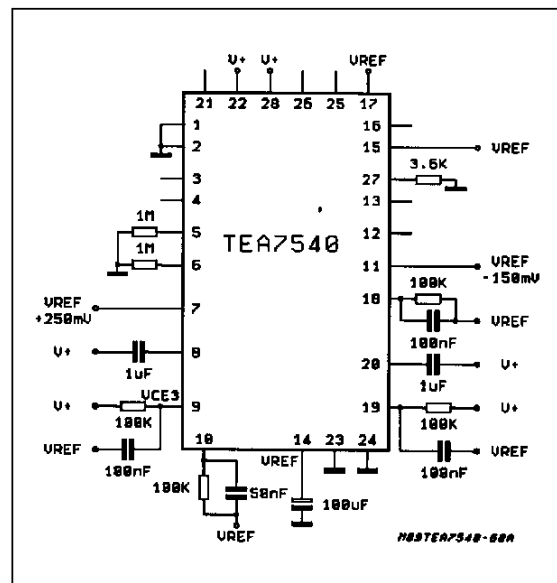

$V^+ = 3V$
pin 7 is forced to transmit mode
pin 11 is forced to minimum gain

Figure 9: Test Configuration

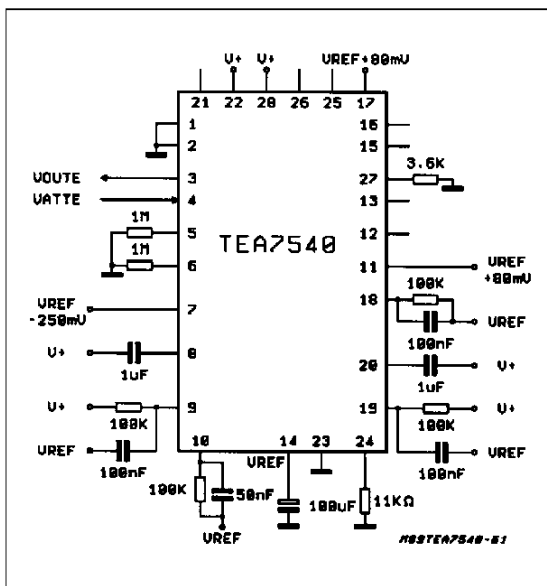

$V^+ = 3V$
pin 7 is forced to receive mode
pin 11 and pin 17 are forced to maximum gain
Input signal on pin 4 VATTE = 200mVpp
 $ATE2 = 20\log(V_{OUTE} / V_{ATTE})$ with $R_{pin24} = 11K\Omega$

Figure 10: Test Configuration

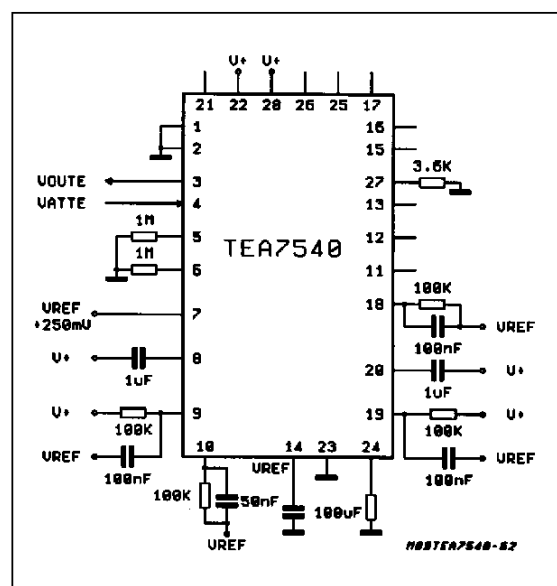

$V^+ = 3V$
pin 7 is forced to transmit mode
Input signal on pin 4 VATTE = 200mVpp
 $ATE = 20\log(V_{OUTE} / V_{ATTE})$

TEA7540

Figure 11: Test Configuration

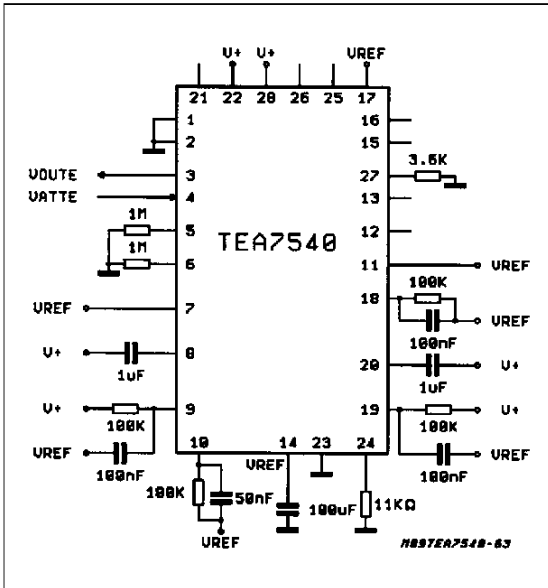

V+ = 3V
 pin 7 is forced to idle mode after that the two compressor have been forced at maximum gain by V11 and V17
 Input signal on pin 4 VATTE = 200mVpp
 Rpin24 = 11KΩ

$$ATE6 = 20\log(VOUTE / VATTE)$$

Figure 12: Test Configuration

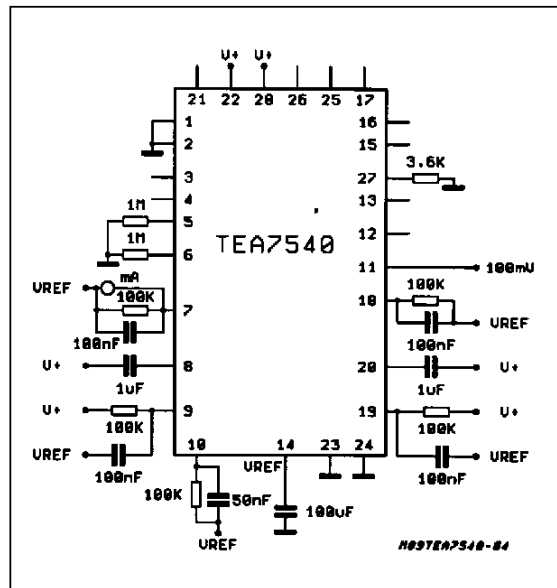

V+ = 3V
 pin 11 is forced to 100mV to force the transmit mode

VTIM_E voltage on pin 7
 ITIM_E current through the mA

Figure 13: Test Configuration

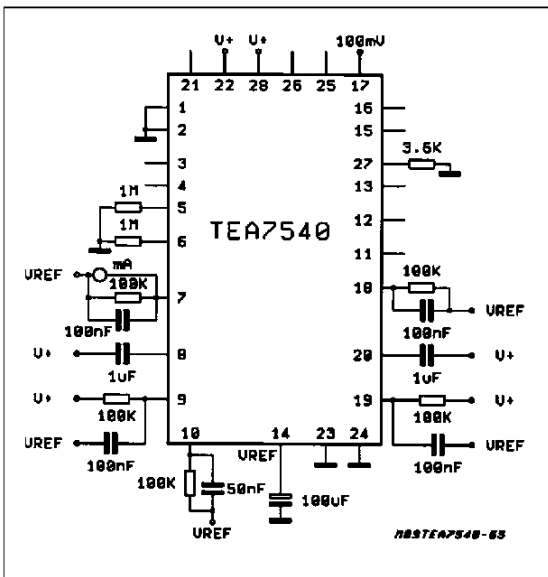

V+ = 3V
 pin 17 is forced to 100mV to force the receive mode

VTIM_R voltage on pin 7
 ITIM_R current through the mA

Figure 14: Test Configuration

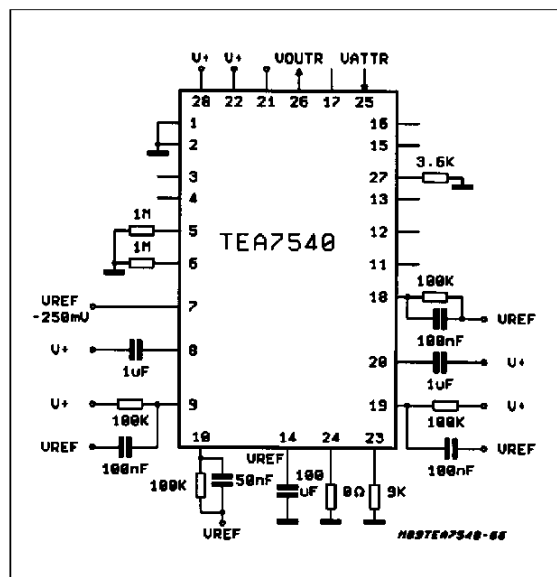

V+ = 3V
 pin 7 is forced to receive mode
 Input signal pin 25: VATTR = 200mVpp
 Rpin23 = 9KΩ

$$ATRVOL = 20\log(VOUTR / VATTR)$$

SO28 PACKAGE MECHANICAL DATA

DIM.	mm			inch		
	MIN.	TYP.	MAX.	MIN.	TYP.	MAX.
A			2.65			0.104
a1	0.1		0.3	0.004		0.012
b	0.35		0.49	0.014		0.019
b1	0.23		0.32	0.009		0.013
C		0.5			0.020	
c1	45° (typ.)					
D	17.7		18.1	0.697		0.713
E	10		10.65	0.394		0.419
e		1.27			0.050	
e3		16.51			0.65	
F	7.4		7.6	0.291		0.299
L	0.4		1.27	0.016		0.050
S	8° (max.)					

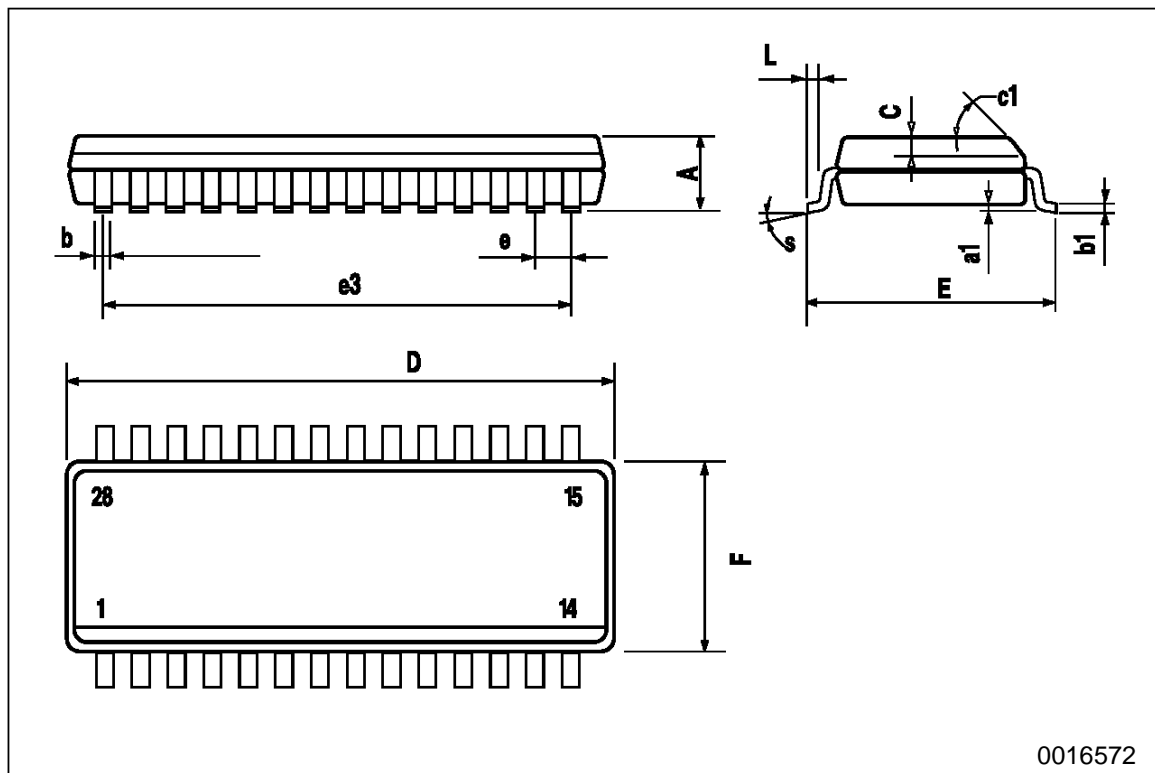

TEA7540

DIP28 PACKAGE MECHANICAL DATA

DIM.	mm			inch		
	MIN.	TYP.	MAX.	MIN.	TYP.	MAX.
a1		0.63			0.025	
b		0.45			0.018	
b1	0.23		0.31	0.009		0.012
b2		1.27			0.050	
D			37.34			1.470
E	15.2		16.68	0.598		0.657
e		2.54			0.100	
e3		33.02			1.300	
F			14.1			0.555
l		4.445			0.175	
L		3.3			0.130	

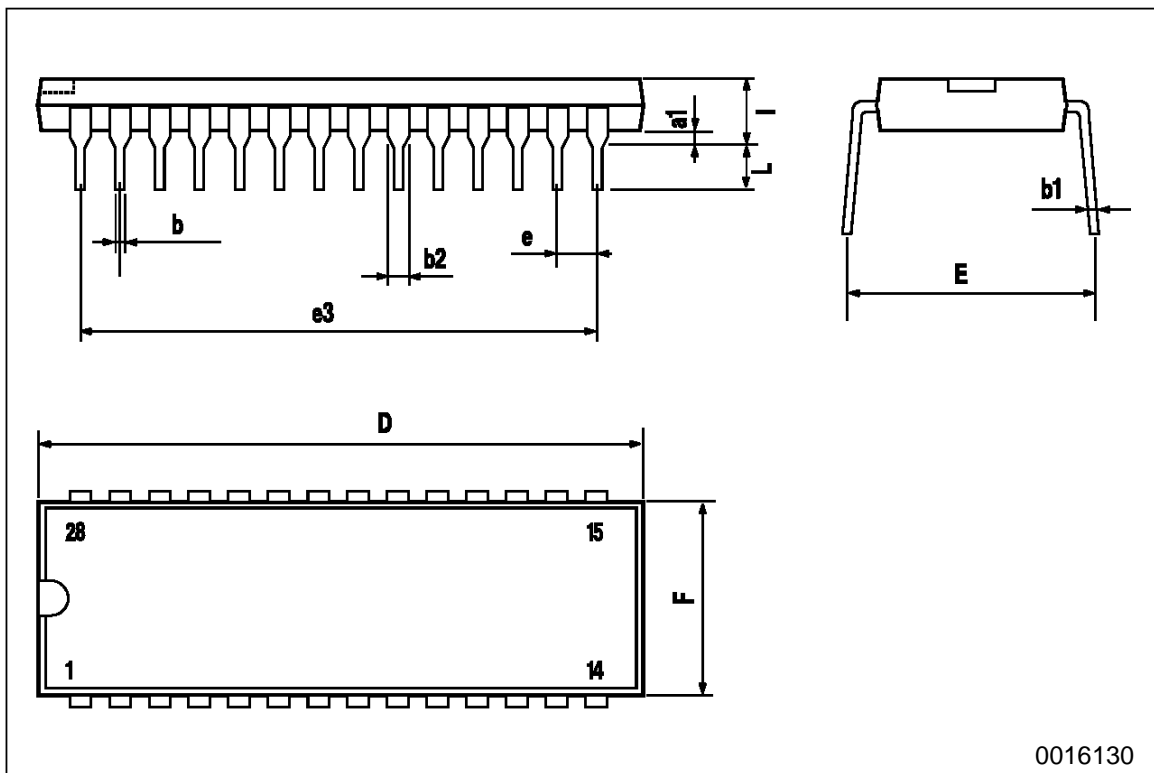

0016130

Information furnished is believed to be accurate and reliable. However, SGS-THOMSON Microelectronics assumes no responsibility for the consequences of use of such information nor for any infringement of patents or other rights of third parties which may result from its use. No license is granted by implication or otherwise under any patent or patent rights of SGS-THOMSON Microelectronics. Specifications mentioned in this publication are subject to change without notice. This publication supersedes and replaces all information previously supplied. SGS-THOMSON Microelectronics products are not authorized for use as critical components in life support devices or systems without express written approval of SGS-THOMSON Microelectronics.

© 1996 SGS-THOMSON Microelectronics All Rights Reserved

SGS-THOMSON Microelectronics GROUP OF COMPANIES

Australia - Brazil - Canada - France - Germany - Hong Kong - Italy - Japan - Korea - Malaysia - Malta - Morocco - The Netherlands
Singapore - Spain - Sweden - Switzerland - Taiwan - Thailand - United Kingdom - U.S.A.