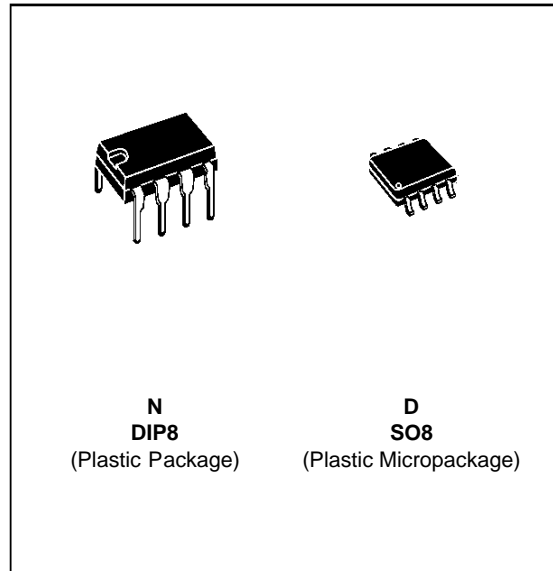

VOLTAGE COMPARATORS

- MAXIMUM INPUT CURRENT : 150nA
- MAXIMUM OFFSET CURRENT : 20nA
- DIFFERENTIAL INPUT VOLTAGE RANGE : $\pm 30V$
- POWER CONSUMPTION : 135mW AT $\pm 15V$
- SUPPLY VOLTAGE : +5V TO $\pm 15V$
- OUTPUT CURRENT : 50mA

DESCRIPTION

The LM111, LM211 and LM311 are voltage comparators that have low input currents.

They are also designed to operate over a wide range of supply voltages : from standard $\pm 15V$ operational amplifier supplies down to the single +5V supply used for IC logic.

Their output is compatible with RTL-DTL and TTL as well as MOS circuits and can switch voltages up to +50V at output currents as high as 50mA.

ORDER CODES

Part Number	Temperature Range	Package	
		N	D
LM111	-55, 125°C	•	•
LM211	-40, 105°C	•	•
LM311	0, 70°C	•	•

Example : LM311D

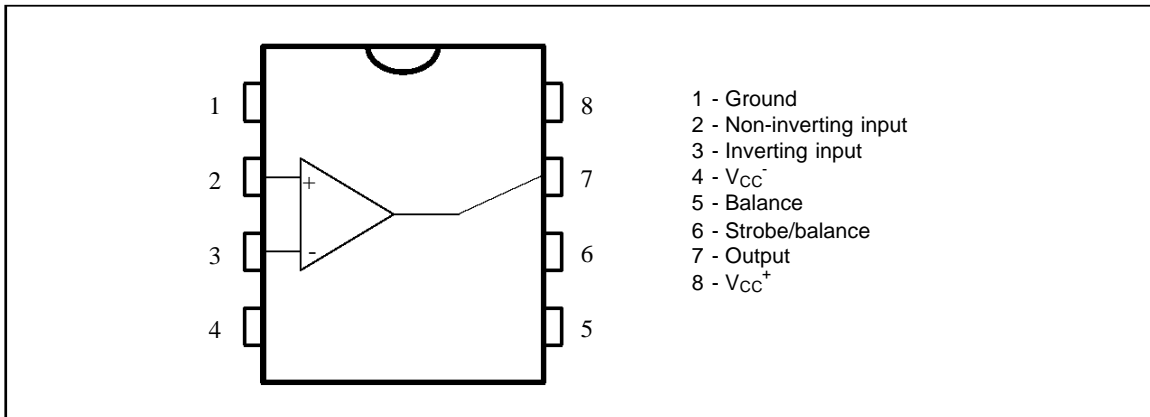
PIN CONNECTIONS (top view)

SCHEMATIC DIAGRAM

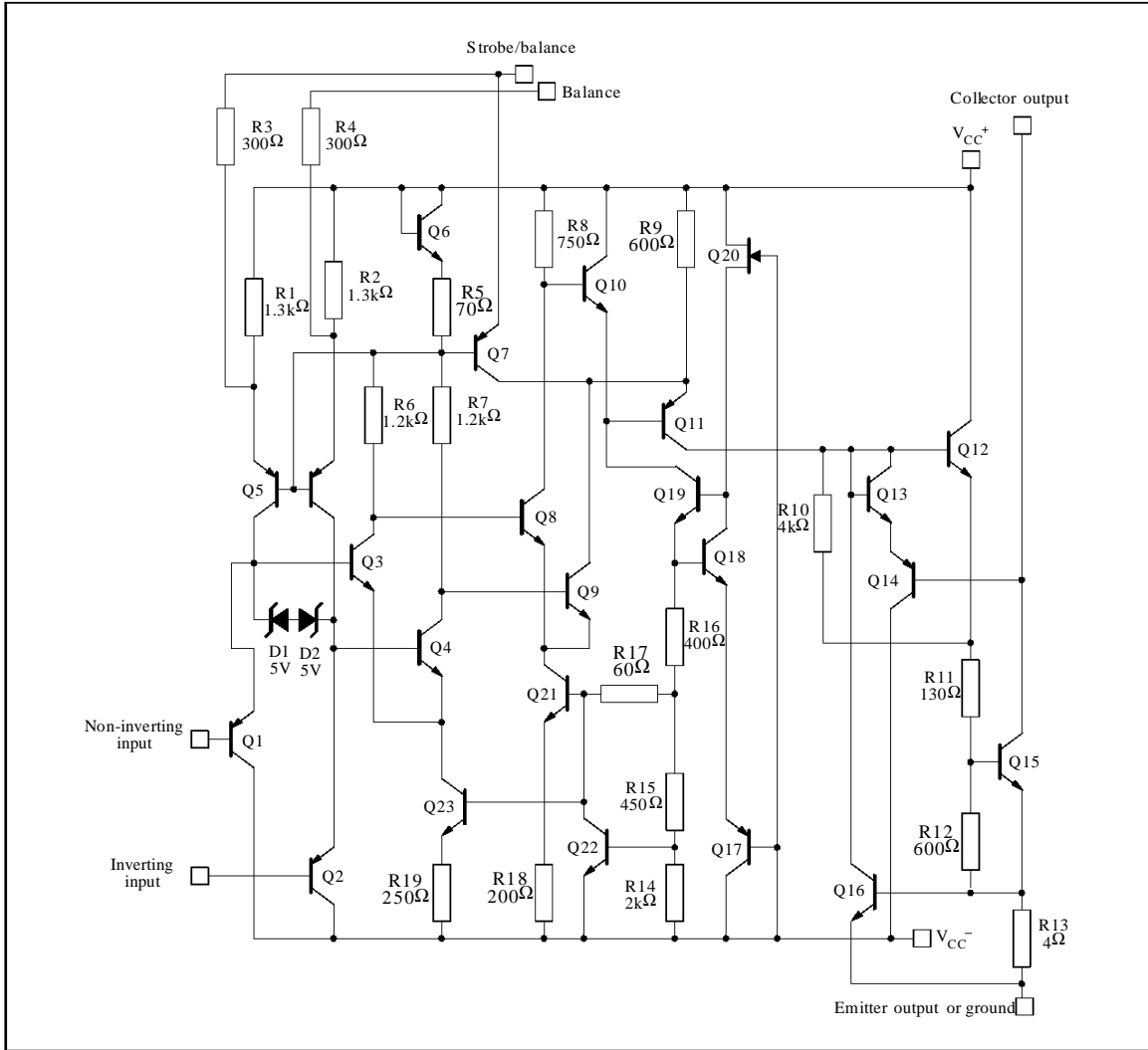

ABSOLUTE MAXIMUM RATINGS

Symbol	Parameter	LM111	LM211	LM311	Unit
V _{CC}	Supply Voltage	36	36	36	V
V _{id}	Differential Input Voltage	±30	±30	±30	V
V _i	Input Voltage – (note 1)	±15	±15	±15	V
P _{tot}	Power Dissipation	500			mW
T _{oper}	Operating Free-air Temperature Range	-55 to +125	-40 to +105	0 to +70	°C
T _{stg}	Storage Temperature Range	-65 to +150	-65 to +150	-65 to +150	°C
V ₍₁₋₄₎	Ground to Negative Supply Voltage	30	30	30	V
V ₍₇₋₄₎	Output to Negative Supply Voltage	50	50	40	V

Output short-circuit duration : 10s
 Voltage at strobe pin : V_{CC}⁺ - 5V

Maximum junction temperature

LM111 : +150°C
 LM211 : +150°C
 LM311 : +150°C

Note : 1. This rating applies for ±15V supplies. The positive input voltage limit is 30V above the negative. The negative input voltage limit is equal to the negative supply voltage or 30V below the positive supply, whichever is less.

ELECTRICAL CHARACTERISTICS

V_{CC} = ±15V, T_{amb} = 25°C (unless otherwise specified)

Symbol	Parameter	LM111 - LM211			LM311			Unit
		Min.	Typ.	Max.	Min.	Typ.	Max.	
V _{io}	Input Offset Voltage (R _S ≤ 50kΩ) – (note 1) T _{amb} = +25°C T _{min.} ≤ T _{amb} ≤ T _{max.}		0.7	3 4		2	7.5 10	mV
I _{io}	Input Offset Current – (note 1) T _{amb} = +25°C T _{min.} ≤ T _{amb} ≤ T _{max.}		4	10 20		6	50 70	nA
I _{ib}	Input Bias Current – (note 1) T _{amb} = +25°C T _{min.} ≤ T _{amb} ≤ T _{max.}		60	100 150		100	250 300	nA
A _{vd}	Large Signal Voltage Gain	40	200		40	200		V/mV
I _{CC+} I _{CC-}	Supply Currents Positive Negative		5.1 4.1	6 5		5.1 4.1	7.5 5	mA
V _{icm}	Input Common Mode Voltage Range T _{min.} ≤ T _{amb} ≤ T _{max.}	-14.5	+13.8 -14.7	+13	-14.5	+13.8 -14.7	+13	V
V _{OL}	Low Level Output Voltage T _{amb} = +25°C, I _O = 50mA V _i ≤ -5mV V _i ≤ -10mV T _{min.} ≤ T _{amb} ≤ T _{max.} V _{CC+} ≥ +4.5 V, V _{CC-} = 0 I _O = 8mA V _i ≤ -6mV V _i ≤ -10mV		0.75	1.5		0.75	1.5	V
I _{OH}	High Level Output Current T _{amb} = +25°C V _i ≥ +5mV, V _O = +35V V _i ≥ +10mV, V _O = +5V T _{min.} ≤ T _{amb} ≤ T _{max.} V _i ≥ +5mV, V _O = +35V		0.2	10		0.2	50	nA nA μA
I _{strobe}	Strobe Current		3			3		mA
t _{re}	Response Time – (note 2)		200			200		ns

Notes : 1. The offset voltage, offset current and bias current specifications apply for any supply voltage from a single +5V supply up to ±15V supplies.

- The offset voltages and offset currents given are the maximum values required to drive the output down to +1V or up to +14V with a 1mA load current. Thus, these parameters define an error band and take into account the worst-case of voltage gain and input impedance.
2. The response time specified (see definitions) is for a 100mV input step with 5mV overdrive.

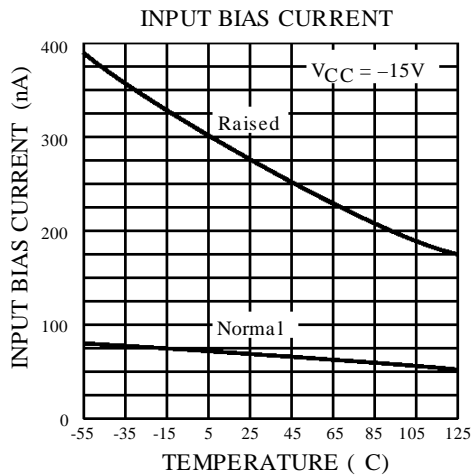
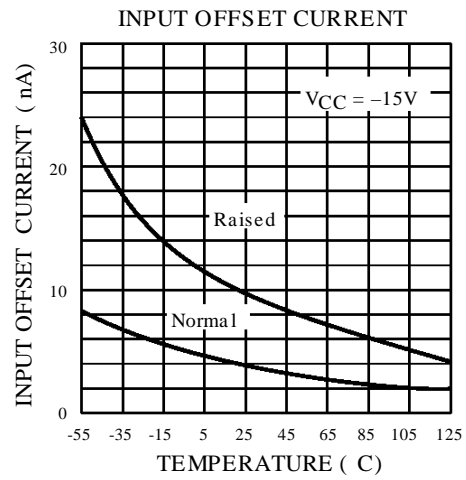
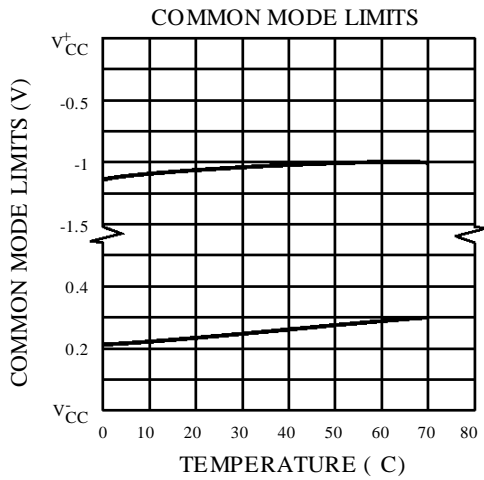
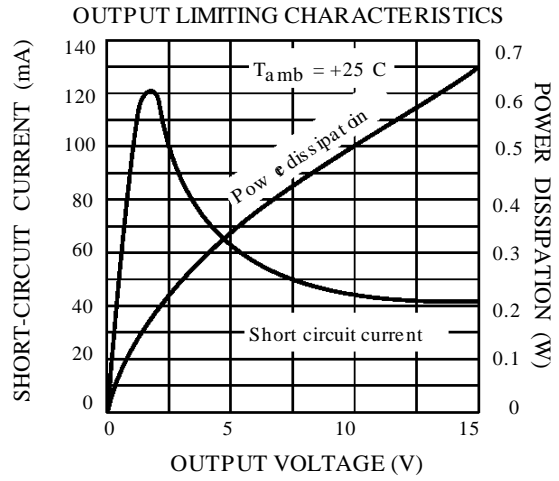
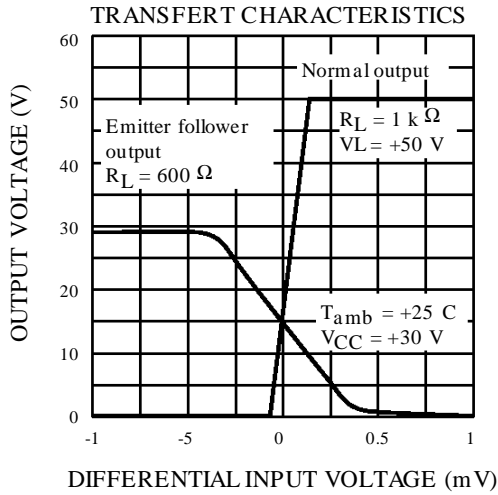

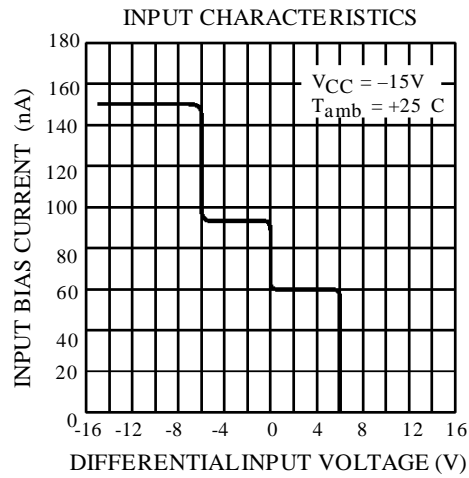
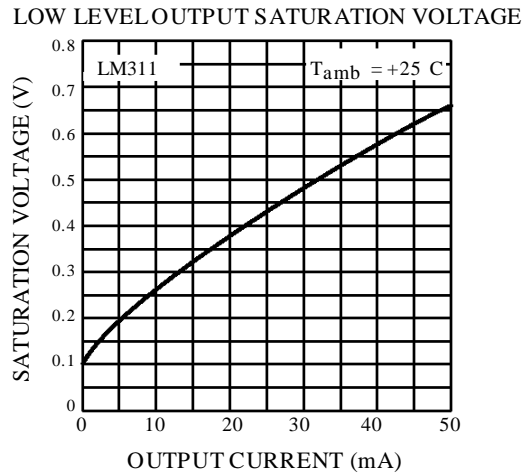
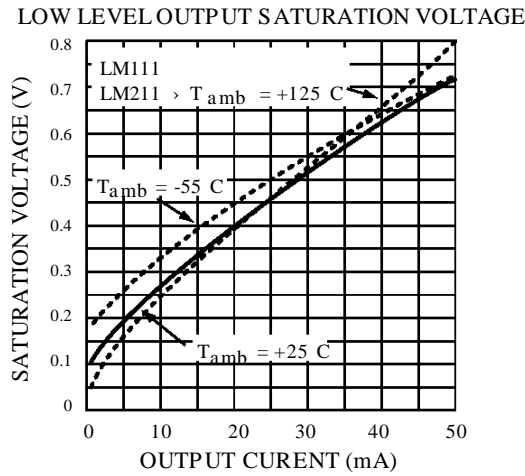
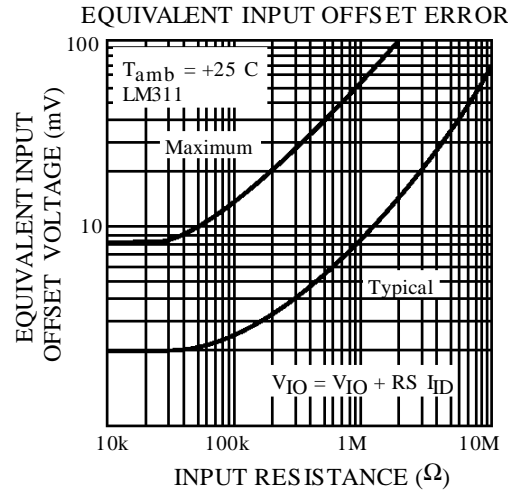
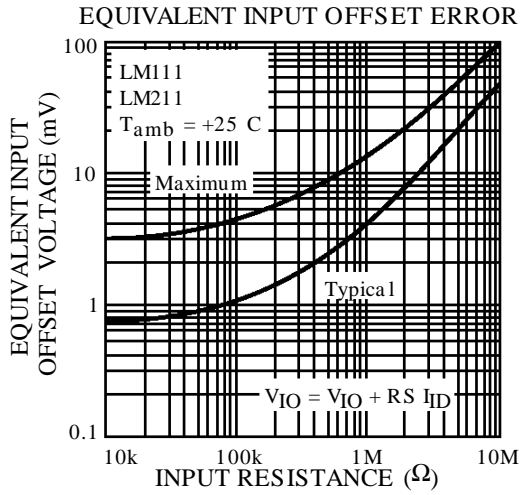

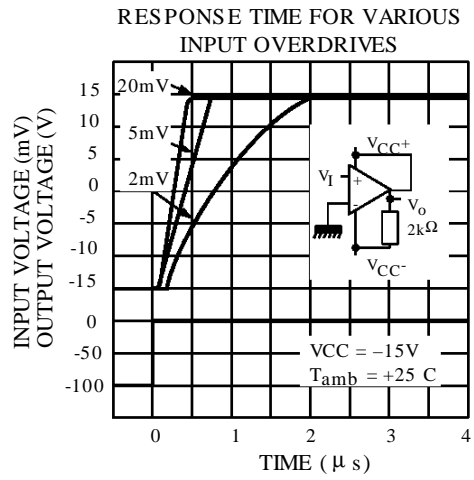
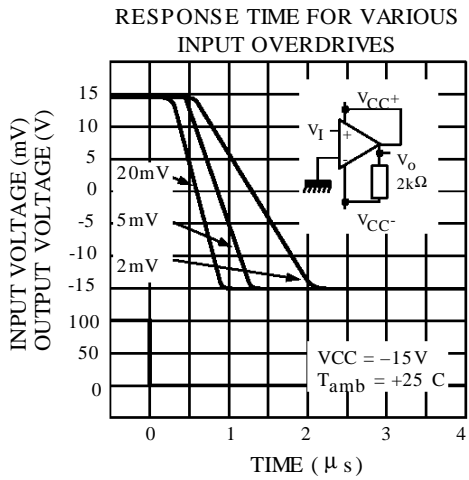
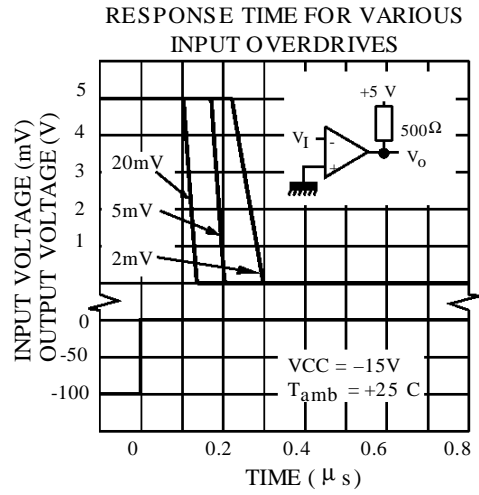
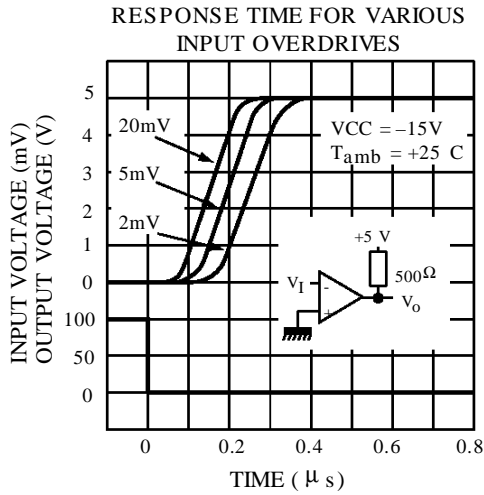

TYPICAL APPLICATIONS

CRYSTAL OSCILLATOR

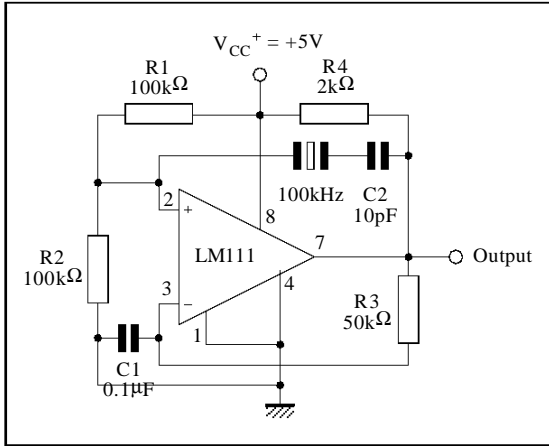

LOW VOLTAGE ADJUSTABLE REFERENCE SUPPLY

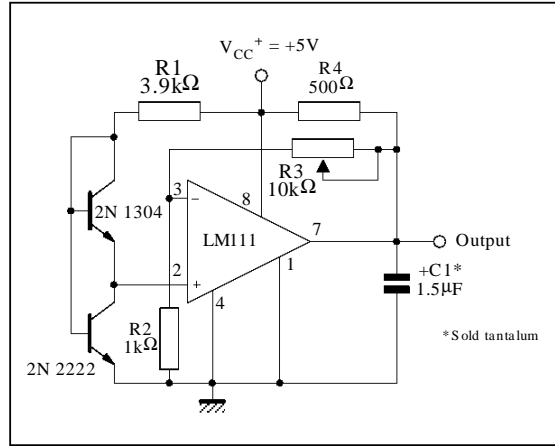

100KHz FREE RUNNING MULTIVIBRATOR

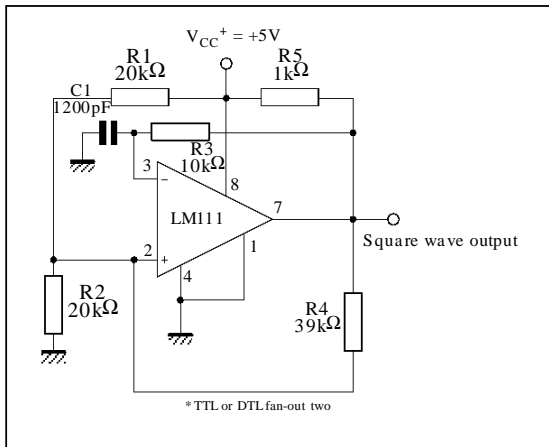

TTL INTERFACE WITH HIGH LEVEL LOGIC

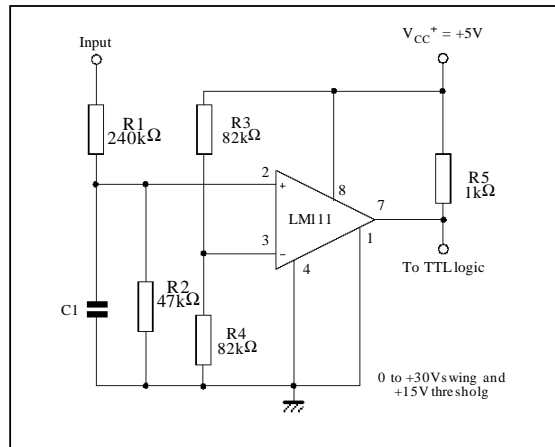

AUXILIARY CIRCUITS

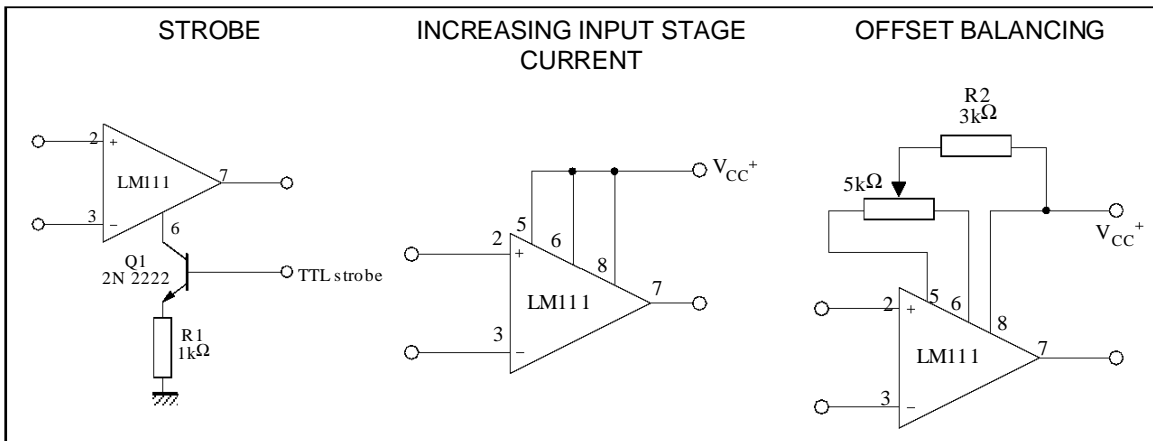

LM111 - LM211 - LM311

PACKAGE MECHANICAL DATA
8 PINS - PLASTIC DIP

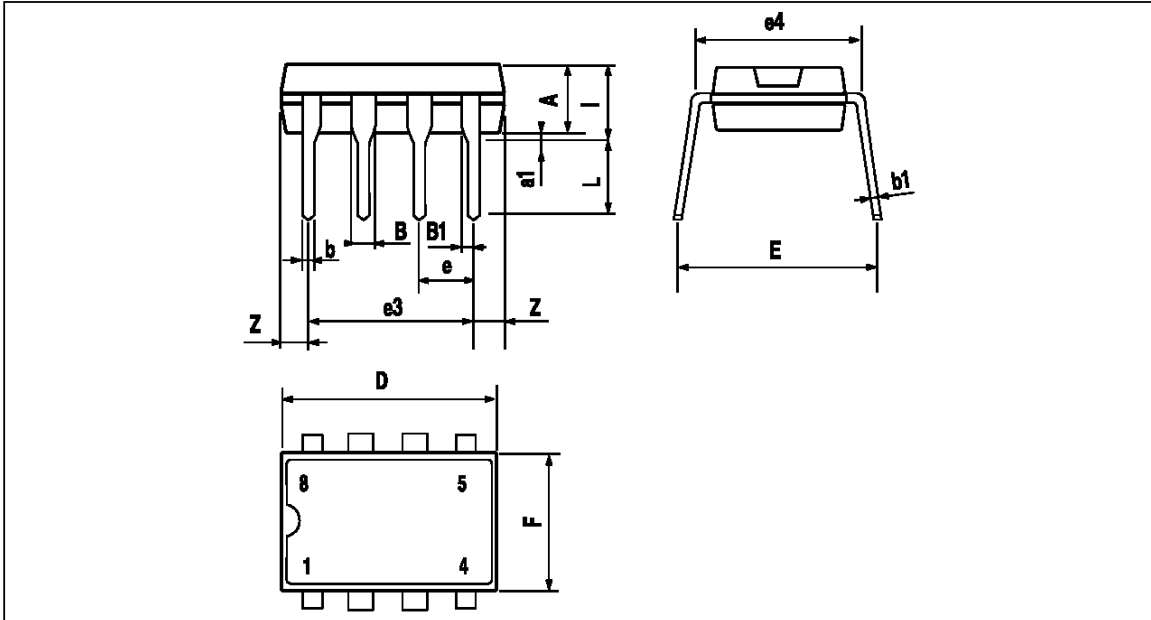

PM4DIP8.EPS

Dim.	Millimeters			Inches		
	Min.	Typ.	Max.	Min.	Typ.	Max.
A		3.32			0.131	
a1	0.51			0.020		
B	1.15		1.65	0.045		0.065
b	0.356		0.55	0.014		0.022
b1	0.204		0.304	0.008		0.012
D			10.92			0.430
E	7.95		9.75	0.313		0.384
e		2.54			0.100	
e3		7.62			0.300	
e4		7.62			0.300	
F			6.6			0.260
i			5.08			0.200
L	3.18		3.81	0.125		0.150
Z			1.52			0.060

DIP8.TBL

PACKAGE MECHANICAL DATA
8 PINS - PLASTIC MICROPACKAGE (SO)

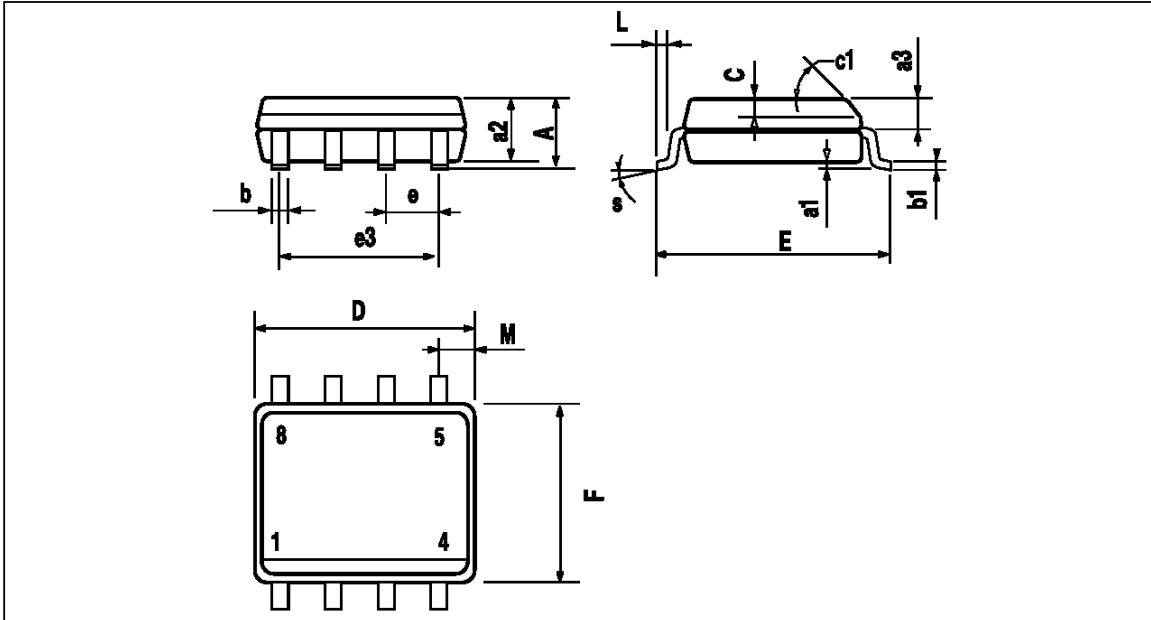

Dim.	Millimeters			Inches		
	Min.	Typ.	Max.	Min.	Typ.	Max.
A			1.75			0.069
a1	0.1		0.25	0.004		0.010
a2			1.65			0.065
a3	0.65		0.85	0.026		0.033
b	0.35		0.48	0.014		0.019
b1	0.19		0.25	0.007		0.010
C	0.25		0.5	0.010		0.020
c1	45° (typ.)					
D	4.8		5.0	0.189		0.197
E	5.8		6.2	0.228		0.244
e		1.27			0.050	
e3		3.81			0.150	
F	3.8		4.0	0.150		0.157
L	0.4		1.27	0.016		0.050
M			0.6			0.024
S	8° (max.)					

Information furnished is believed to be accurate and reliable. However, SGS-THOMSON Microelectronics assumes no responsibility for the consequences of use of such information nor for any infringement of patents or other rights of third parties which may result from its use. No license is granted by implication or otherwise under any patent or patent rights of SGS-THOMSON Microelectronics. Specifications mentioned in this publication are subject to change without notice. This publication supersedes and replaces all information previously supplied. SGS-THOMSON Microelectronics products are not authorized for use as critical components in life support devices or systems without express written approval of SGS-THOMSON Microelectronics.

© 1997 SGS-THOMSON Microelectronics – Printed in Italy – All Rights Reserved

SGS-THOMSON Microelectronics GROUP OF COMPANIES
Australia - Brazil - Canada - China - France - Germany - Hong Kong - Italy - Japan - Korea - Malaysia - Malta - Morocco
The Netherlands - Singapore - Spain - Sweden - Switzerland - Taiwan - Thailand - United Kingdom - U.S.A.