

Hi-Speed USB Host, Device or OTG PHY with ULPI Low Pin Interface

PRODUCT FEATURES

Datasheet

- USB-IF Hi-Speed certified to the Universal Serial Bus Specification Rev 2.0
- Interface compliant with the ULPI Specification revision 1.1 in 8-bit mode
- Industry standard UTMI+ Low Pin Interface (ULPI) Converts 54 UTMI+ signals into a standard 12 pin Link controller interface
- 54.7mA Unconfigured Current (typical) - ideal for bus powered applications
- 83uA suspend current (typical) - ideal for battery powered applications
- Latch-Up performance exceeds 150 mA per EIA/JESD 78, Class II
- ESD protection levels of ± 8 kV HBM without external protection devices
- Integrated protection to withstand IEC61000-4-2 ESD tests (± 8 kV contact and ± 15 kV air) per 3rd party test facility
- Supports FS pre-amble for FS hubs with a LS device attached (UTMI+ Level 3)
- Supports HS SOF and LS keep-alive pulse
- Includes full support for the optional On-The-Go (OTG) protocol detailed in the On-The-Go Supplement Revision 1.0a specification
- Supports the OTG Host Negotiation Protocol (HNP) and Session Request Protocol (SRP)
- Allows host to turn VBUS off to conserve battery power in OTG applications
- Supports OTG monitoring of VBUS levels with internal comparators. Includes support for an external VBUS or fault monitor.
- Low Latency Hi-Speed Receiver (43 Hi-Speed clocks Max) allows use of legacy UTMI Links with a ULPI wrapper
- Integrated Pull-up resistor on STP for interface protection allows a reliable Link/PHY start-up with slow Links (software configured for low power)
- Internal 1.8 volt regulators allow operation from a single 3.3 volt supply
- Internal short circuit protection of ID, DP and DM lines to VBUS or ground
- Integrated 24MHz Crystal Oscillator supports either crystal operation or 24MHz external clock input
- Internal PLL for 480MHz Hi-Speed USB operation
- Industrial Operating Temperature -40°C to $+85^{\circ}\text{C}$
- 32 pin QFN package; green, lead-free (5 x 5 x 0.90 mm height)

APPLICATIONS

The USB3300 is the ideal companion to any ASIC, SoC or FPGA solution designed with a ULPI Hi-Speed USB host, peripheral or OTG core.

The USB3300 is well suited for:

- Cell Phones
- PDAs
- MP3 Players
- Scanners
- External Hard Drives
- Digital Still and Video Cameras
- Portable Media Players
- Printers

ORDER NUMBER:**USB3300-EZK FOR 32 PIN, QFN PACKAGE (GREEN, LEAD-FREE)**

80 ARKAY DRIVE, HAUPPAUGE, NY 11788 (631) 435-6000, FAX (631) 273-3123

Copyright © 2006 SMSC or its subsidiaries. All rights reserved.

Circuit diagrams and other information relating to SMSC products are included as a means of illustrating typical applications. Consequently, complete information sufficient for construction purposes is not necessarily given. Although the information has been checked and is believed to be accurate, no responsibility is assumed for inaccuracies. SMSC reserves the right to make changes to specifications and product descriptions at any time without notice. Contact your local SMSC sales office to obtain the latest specifications before placing your product order. The provision of this information does not convey to the purchaser of the described semiconductor devices any licenses under any patent rights or other intellectual property rights of SMSC or others. All sales are expressly conditional on your agreement to the terms and conditions of the most recently dated version of SMSC's standard Terms of Sale Agreement dated before the date of your order (the "Terms of Sale Agreement"). The product may contain design defects or errors known as anomalies which may cause the product's functions to deviate from published specifications. Anomaly sheets are available upon request. SMSC products are not designed, intended, authorized or warranted for use in any life support or other application where product failure could cause or contribute to personal injury or severe property damage. Any and all such uses without prior written approval of an Officer of SMSC and further testing and/or modification will be fully at the risk of the customer. Copies of this document or other SMSC literature, as well as the Terms of Sale Agreement, may be obtained by visiting SMSC's website at <http://www.smsc.com>. SMSC is a registered trademark of Standard Microsystems Corporation ("SMSC"). Product names and company names are the trademarks of their respective holders.

SMSC DISCLAIMS AND EXCLUDES ANY AND ALL WARRANTIES, INCLUDING WITHOUT LIMITATION ANY AND ALL IMPLIED WARRANTIES OF MERCHANTABILITY, FITNESS FOR A PARTICULAR PURPOSE, TITLE, AND AGAINST INFRINGEMENT AND THE LIKE, AND ANY AND ALL WARRANTIES ARISING FROM ANY COURSE OF DEALING OR USAGE OF TRADE. IN NO EVENT SHALL SMSC BE LIABLE FOR ANY DIRECT, INCIDENTAL, INDIRECT, SPECIAL, PUNITIVE, OR CONSEQUENTIAL DAMAGES; OR FOR LOST DATA, PROFITS, SAVINGS OR REVENUES OF ANY KIND; REGARDLESS OF THE FORM OF ACTION, WHETHER BASED ON CONTRACT; TORT; NEGLIGENCE OF SMSC OR OTHERS; STRICT LIABILITY; BREACH OF WARRANTY; OR OTHERWISE; WHETHER OR NOT ANY REMEDY OF BUYER IS HELD TO HAVE FAILED OF ITS ESSENTIAL PURPOSE, AND WHETHER OR NOT SMSC HAS BEEN ADVISED OF THE POSSIBILITY OF SUCH DAMAGES.



Datasheet

0.1 Reference Documents

- Universal Serial Bus Specification, Revision 2.0, April 27, 2000
- On-The-Go Supplement to the USB 2.0 Specification, Revision 1.0a, June 24, 2003
- USB 2.0 Transceiver Macrocell Interface (UTMI) Specification, Version 1.02, May 27, 2000
- UTMI+ Specification, Revision 1.0, February 2, 2004
- UTMI+ Low Pin Interface (ULPI) Specification, Revision 1.1

Table of Contents

0.1 Reference Documents	3
Chapter 1 General Description	7
Chapter 2 Functional Overview	9
Chapter 3 Pin Layout	10
3.1 USB3300 Pin Diagram	10
3.2 Pin Function.	10
Chapter 4 Operational Description.	14
Chapter 5 Electrical Characteristics.	15
Chapter 6 Architecture Overview	19
6.1 ULPI Digital	19
6.1.1 Overview	19
6.1.2 ULPI Interface Signals	21
6.1.3 ULPI Interface Timing	22
6.1.4 ULPI Register Array.	22
6.1.5 ULPI Register Access	28
6.1.6 ULPI RXD CMD.	30
6.1.7 USB3300 Transmitter	31
6.1.8 USB3300 Receiver	33
6.1.9 Low Power Mode	34
6.1.10 Full Speed/Low Speed Serial Modes.	37
6.1.11 Reset Pin	38
6.2 Hi-Speed USB Transceiver	38
6.2.1 High Speed and Full Speed Transceivers	38
6.2.2 Termination Resistors	38
6.2.3 Bias Generator.	40
6.3 Crystal Oscillator and PLL	40
6.4 Internal Regulators and POR	40
6.4.1 Internal Regulators	41
6.4.2 Power On Reset (POR)	41
6.5 USB On-The-Go (OTG) Module	41
6.5.1 ID Detection	42
6.5.2 VBUS Control	43
6.5.3 Driving External Vbus	44
6.5.4 External Vbus Indicator	44
Chapter 7 Application Notes	46
7.1 Application Diagram	46
7.2 Multi-port Applications	46
7.3 Evaluation Board	47
7.4 ESD Performance	47
7.4.1 Human Body Model (HBM) Performance	47
7.4.2 IEC61000-4-2 Performance.	48
Chapter 8 Package Outline	49

Datasheet**List of Figures**

Figure 1.1	Basic ULPI USB Device Block Diagram.	7
Figure 1.2	ULPI Interface Features as Related to UTMI+.	8
Figure 2.1	USB3300 Block Diagram	9
Figure 3.1	USB3300 Pin Diagram - Top View.	10
Figure 6.1	Simplified USB3300 Architecture.	19
Figure 6.2	ULPI Digital Block Diagram	20
Figure 6.3	ULPI Timing Diagram.	22
Figure 6.4	ULPI Register Write	29
Figure 6.5	ULPI Register Read	30
Figure 6.6	ULPI Transmit	33
Figure 6.7	ULPI Receive	34
Figure 6.8	Entering Low Power Mode	35
Figure 6.9	Exiting Low Power Mode	36
Figure 6.10	USB3300 On-the-Go Module	42
Figure 7.1	USB3300 Application Diagram.	46
Figure 7.2	Expanding Downstream Ports for USB3300 Host Applications	47
Figure 8.1	USB3300-EZK 32 Pin QFN Package Outline, 5 x 5 x 0.9 mm Body (Lead-Free)	49

List of Tables

Table 3.1	USB3300 Pin Definitions 32-Pin QFN Package	10
Table 4.1	Maximum Guaranteed Ratings	14
Table 4.2	Recommended Operating Conditions	14
Table 5.1	Electrical Characteristics: Supply Pins	15
Table 5.2	Electrical Characteristics: CLKOUT Start-Up	15
Table 5.3	DC Electrical Characteristics: Logic Pins	16
Table 5.4	DC Electrical Characteristics: Analog I/O Pins (DP/DM)	16
Table 5.5	Dynamic Characteristics: Analog I/O Pins (DP/DM)	17
Table 5.6	OTG Electrical Characteristics	18
Table 5.7	Regulator Output Voltages	18
Table 6.1	ULPI Interface Signals	21
Table 6.2	ULPI Interface Timing	22
Table 6.3	ULPI Register Map	23
Table 6.4	ULPI TXD CMD Byte Encoding	28
Table 6.5	ULPI RX CMD Encoding	31
Table 6.6	Interface Signal Mapping During Low Power Mode	35
Table 6.7	Pin Definitions in 3 pin Serial Mode	38
Table 6.8	DP/DM termination vs. Signaling Mode	39
Table 6.9	IdGnd vs. USB Cable Type	42
Table 6.10	External Vbus Indicator Logic	44
Table 8.1	32 Terminal QFN Package Parameters	49

Chapter 1 General Description

The USB3300 is an industrial temperature Hi-Speed USB Physical Layer Transceiver (PHY). The USB3300 uses a low pin count interface (ULPI) to connect to a ULPI compliant Link layer. The ULPI interface reduces the UTMI+ interface from 54 pins to 12 pins using a method of in-band signaling and status byte transfers between the Link and PHY.

This PHY was designed from the start with the ULPI interface. No UTMI to ULPI wrappers are used in this design which provides a seamless ULPI to Link interface. The result is a PHY with a low latency transmit and receive time. SMSC's low latency high speed and full speed receiver provide the option of re-using existing UTMI Links with a simple wrapper to convert UTMI to ULPI.

The ULPI interface allows the USB3300 PHY to operate as a device, host, or an On-The-Go (OTG) device. Designs using the USB3300 PHY as a device, can add host and OTG capability at a later date with no additional pins.

The ULPI interface, combined with SMSC's proprietary technology, makes the USB3300 the ideal method of adding Hi-Speed USB to new designs. The USB3300 features an industry leading small footprint package (5mm by 5mm) with sub 1mm height. In addition the USB3300 integrates all DP and DM termination resistances and requires a minimal number of external components.

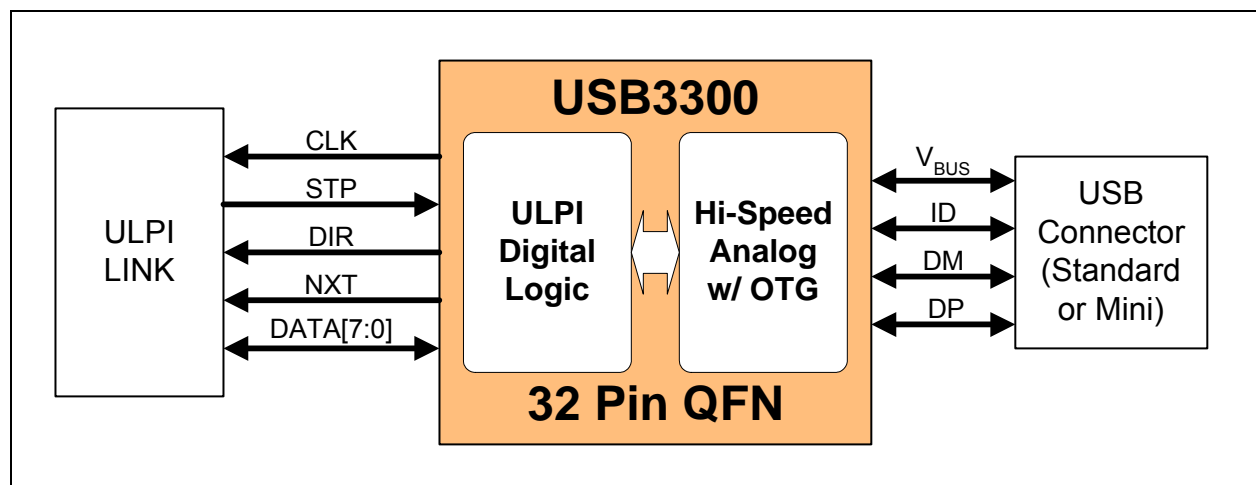

Figure 1.1 Basic ULPI USB Device Block Diagram

The ULPI interface consists of 12 interface pins; 8 bi-directional data pins, 3 control pins, and a 60 MHz clock. By using the 12 pin ULPI interface the USB3300 is able to provide support for the full range of UTMI+ Level 3 through Level 0, as shown in Figure 1.2. This allows USB3300 to work as a HS and FS peripheral and as a HS, FS, and LS Host.

The USB3300 can also, as an option, fully support the On-the-Go (OTG) protocol defined in the On-The-Go Supplement to the USB 2.0 Specification. On-the-Go allows the USB3300 to function like a host, or peripheral configured dynamically by software. For example, a cell phone may connect to a computer as a peripheral to exchange address information or connect to a printer as a host to print pictures. Finally the OTG enabled device can connect to another OTG enabled device to exchange information. All this is supported using a single low profile Mini-AB USB connector.

Designs not needing OTG can ignore the OTG feature set.

In addition to the advantages of the leading edge ULPI interface, the use of SMSC's advanced analog technology enables the USB3300 to consume a minimum amount of power which results in maximized battery life for portable applications.

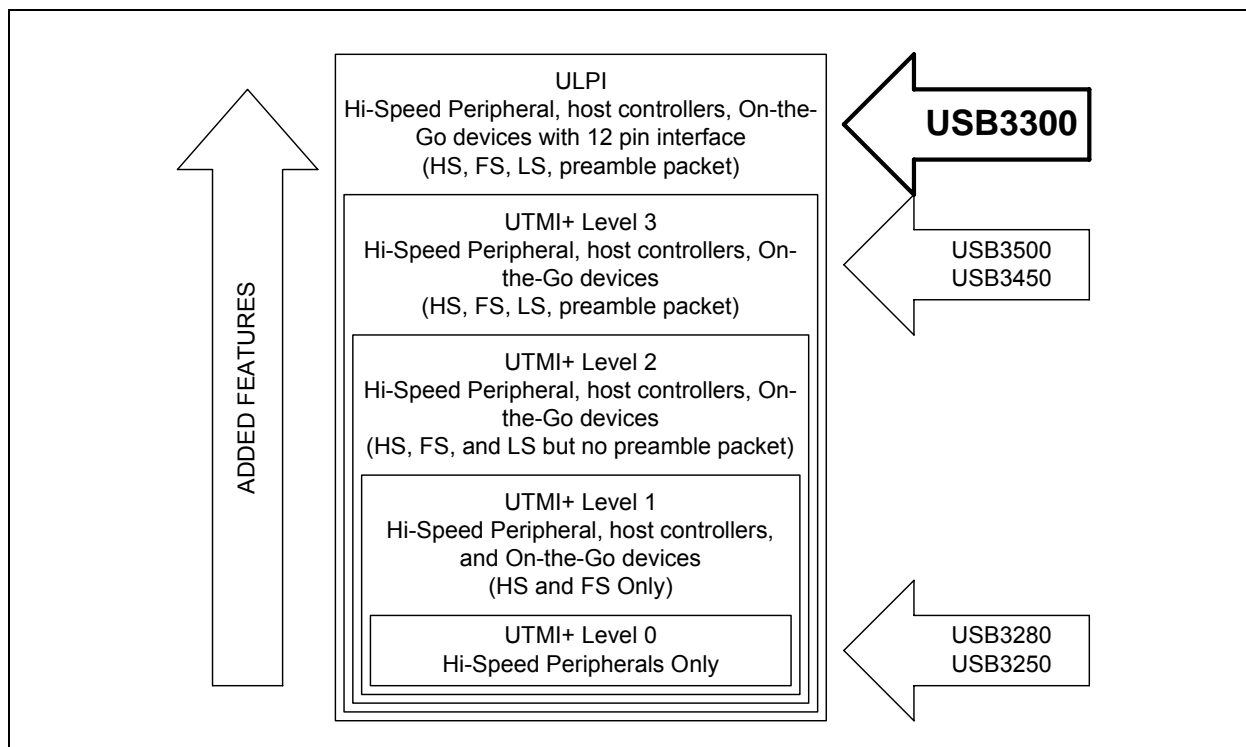

Figure 1.2 ULPI Interface Features as Related to UTMI+

Chapter 2 Functional Overview

The USB3300 is a highly integrated USB PHY. It contains a complete Hi-Speed USB2.0 PHY with the ULPI industry standard interface to support fast time to market for a USB product. The USB3300 is composed of the functional blocks shown in [Figure 2.1](#) below. Details of these individual blocks are described in [Chapter 6, "Architecture Overview,"](#) on page 19.

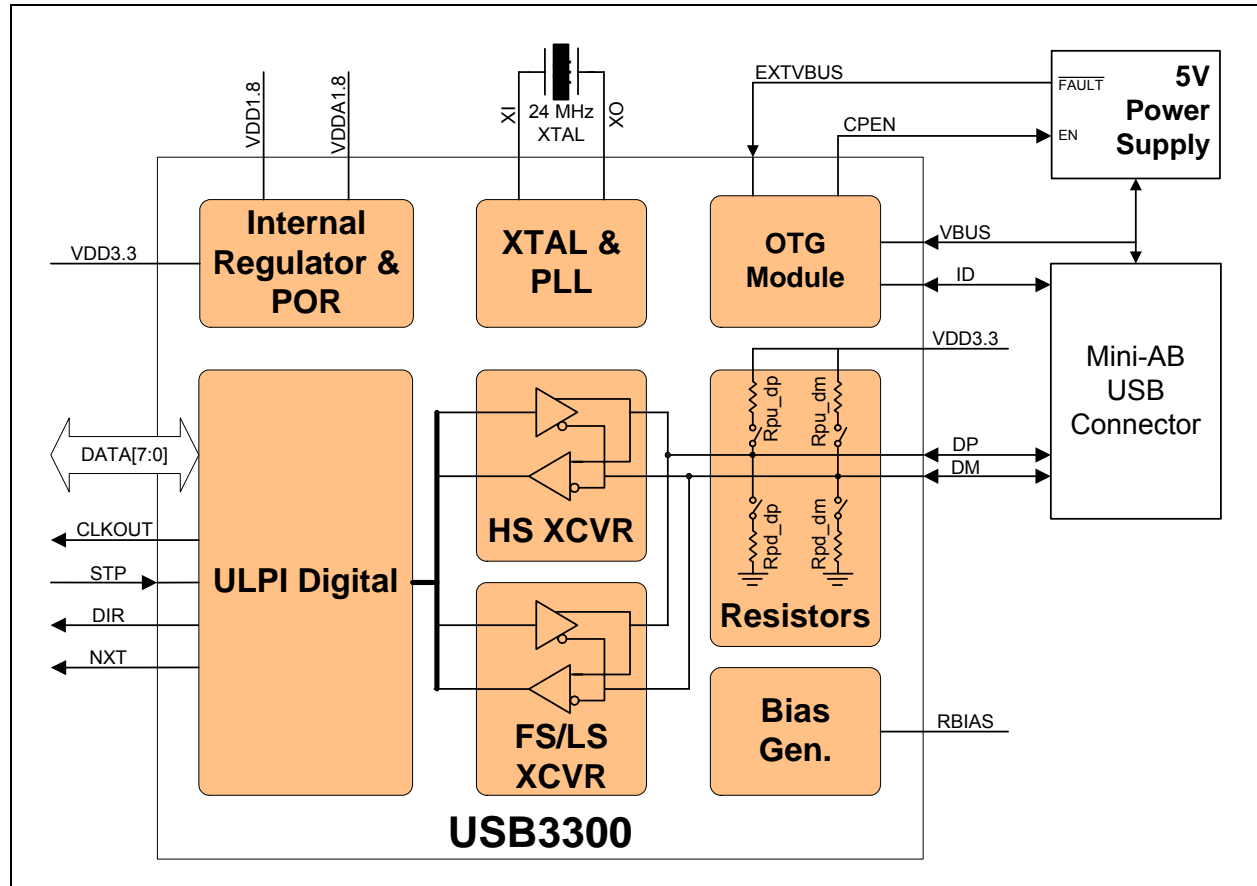

Figure 2.1 USB3300 Block Diagram

Chapter 3 Pin Layout

The USB3300 is offered in a 32 pin QFN package (5 x 5 x 0.9mm). The pin definitions and locations are documented below.

3.1 USB3300 Pin Diagram

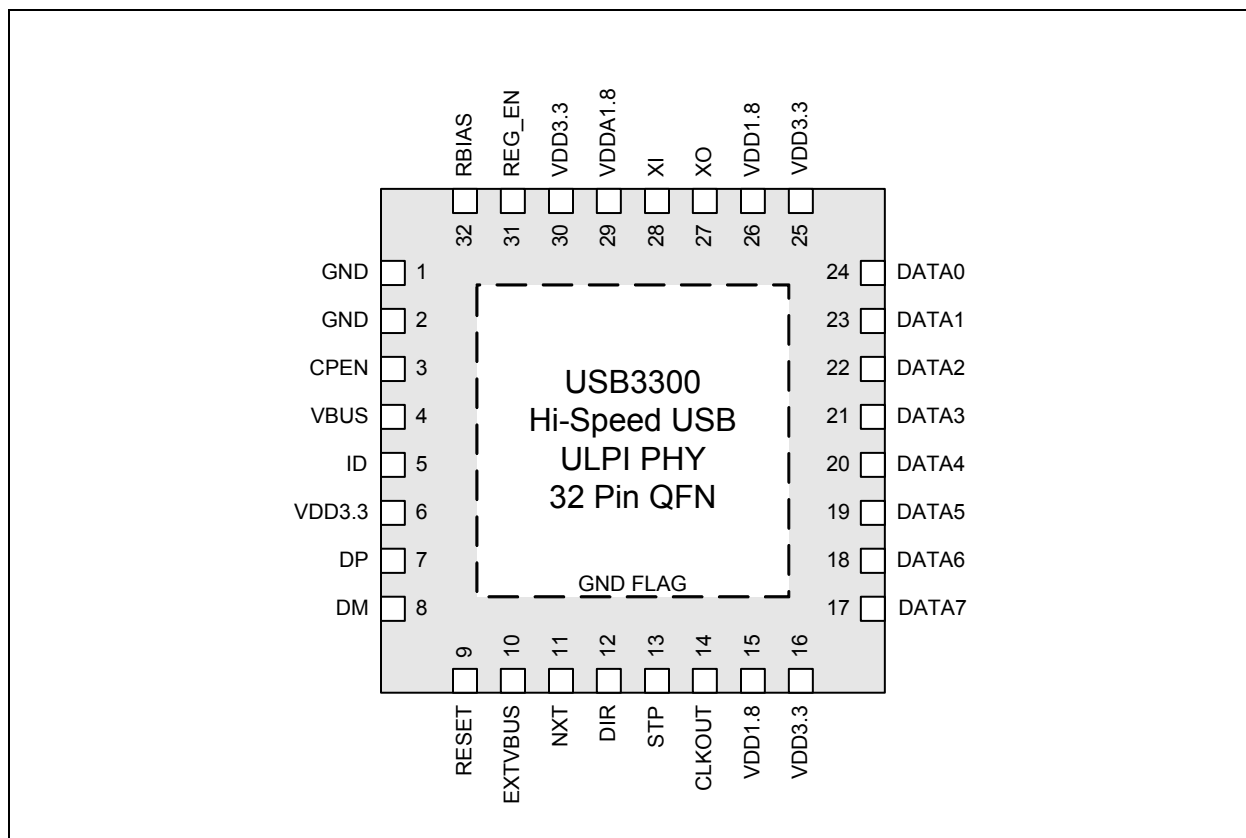

Figure 3.1 USB3300 Pin Diagram - Top View

The exposed flag of the QFN package must be connected to ground with a via array to the ground plane. This is the main ground connection for the USB3300.

3.2 Pin Function

Table 3.1 USB3300 Pin Definitions 32-Pin QFN Package

PIN	NAME	DIRECTION, TYPE	ACTIVE LEVEL	DESCRIPTION
1	GND	Ground	N/A	Ground
2	GND	Ground	N/A	Ground
3	CPEN	Output, CMOS	High	External 5 volt supply enable. This pin is used to enable the external Vbus power supply. The CPEN pin is low on POR.

Table 3.1 USB3300 Pin Definitions 32-Pin QFN Package (continued)

PIN	NAME	DIRECTION, TYPE	ACTIVE LEVEL	DESCRIPTION
4	VBUS	I/O, Analog	N/A	VBUS pin of the USB cable. The USB3300 uses this pin for the Vbus comparator inputs and for Vbus pulsing during session request protocol.
5	ID	Input, Analog	N/A	ID pin of the USB cable. For non-OTG applications this pin can be floated. For an A-Device ID = 0. For a B-Device ID = 1.
6	VDD3.3	Power	N/A	3.3V Supply. A 0.1uF bypass capacitor should be connected between this pin and the ground plane on the PCB.
7	DP	I/O, Analog	N/A	D+ pin of the USB cable.
8	DM	I/O, Analog	N/A	D- pin of the USB cable.
9	RESET	Input, CMOS	High	Optional active high transceiver reset. This is the same as a write to the ULPI <i>Reset</i> , address 04h, bit 5. This does not reset the ULPI register set. This signal must be de-asserted synchronous to CLKOUT. This pin includes an integrated pull-down resistor to ground. If not used this pin can be floated or connected to ground (recommended).
10	EXTVBUS	Input, CMOS	High	External Vbus Detect. Connect to fault output of an external USB power switch or an external Vbus Valid comparator. See Section 6.5.4, "External Vbus Indicator," on page 44 for details. This pin has a pull down resistor to prevent it from floating when the ULPI bit <i>UseExternalVbusIndicator</i> is set to 0.
11	NXT	Output, CMOS	High	The PHY asserts NXT to throttle the data. When the Link is sending data to the PHY, NXT indicates when the current byte has been accepted by the PHY. The Link places the next byte on the data bus in the following clock cycle.
12	DIR	Output, CMOS	N/A	Controls the direction of the data bus. When the PHY has data to transfer to the Link, it drives DIR high to take ownership of the bus. When the PHY has no data to transfer it drives DIR low and monitors the bus for commands from the Link. The PHY will pull DIR high whenever the interface cannot accept data from the Link, such as during PLL start-up.
13	STP	Input, CMOS	High	The Link asserts STP for one clock cycle to stop the data stream currently on the bus. If the Link is sending data to the PHY, STP indicates the last byte of data was on the bus in the previous cycle. The STP pin also includes the interface protection detailed in Section 6.1.9.3, "Interface Protection," on page 36 .
14	CLKOUT	Output, CMOS	N/A	60MHz reference clock output. All ULPI signals are driven synchronous to the rising edge of this clock.
15	VDD1.8	Power	N/A	1.8V regulator output for digital circuitry on chip. Place a 0.1uF capacitor near this pin and connect the capacitor from this pin to ground. Connect pin 15 to pin 26.
16	VDD3.3	Power	N/A	A 0.1uF bypass capacitor should be connected between this pin and the ground plane on the PCB.

Table 3.1 USB3300 Pin Definitions 32-Pin QFN Package (continued)

PIN	NAME	DIRECTION, TYPE	ACTIVE LEVEL	DESCRIPTION
17	DATA[7]	I/O, CMOS, Pull-low	N/A	8-bit bi-directional data bus. Bus ownership is determined by DIR. The Link and PHY initiate data transfers by driving a non-zero pattern onto the data bus. ULPI defines interface timing for a single-edge data transfers with respect to rising edge of CLKOUT. DATA[7] is the MSB and DATA[0] is the LSB.
18	DATA[6]	I/O, CMOS, Pull-low	N/A	
19	DATA[5]	I/O, CMOS, Pull-low	N/A	
20	DATA[4]	I/O, CMOS, Pull-low	N/A	
21	DATA[3]	I/O, CMOS, Pull-low	N/A	
22	DATA[2]	I/O, CMOS, Pull-low	N/A	
23	DATA[1]	I/O, CMOS, Pull-low	N/A	
24	DATA[0]	I/O, CMOS, Pull-low	N/A	
25	VDD3.3	Power	N/A	A 0.1uF bypass capacitor should be connected between this pin and the ground plane on the PCB.
26	VDD1.8	Power	N/A	1.8V regulator output for digital circuitry on chip. Place a 4.7uF low ESR capacitor near this pin and connect the capacitor from this pin to ground. Connect pin 26 to pin 15. See Section 6.4.1, "Internal Regulators" for more information.
27	XO	Output, Analog	N/A	Crystal pin. If using an external clock on XI this pin should be floated.
28	XI	Input, Analog	N/A	Crystal pin. A 24MHz crystal is supported. The crystal is placed across XI and XO. An external 24MHz clock source may be driven into XI in place of a crystal.
29	VDDA1.8	Power	N/A	1.8V regulator output for analog circuitry on chip. Place a 0.1uF capacitor near this pin and connect the capacitor from this pin to ground. In parallel, place a 4.7uF low ESR capacitor near this pin and connect the capacitor from this pin to ground. See Section 6.4.1, "Internal Regulators" for more information.
30	VDD3.3	Power	N/A	Analog 3.3 volt supply. A 0.1uF low ESR bypass capacitor connected to the ground plane of the PCB is recommended.

Table 3.1 USB3300 Pin Definitions 32-Pin QFN Package (continued)

PIN	NAME	DIRECTION, TYPE	ACTIVE LEVEL	DESCRIPTION
31	REG_EN	I/O, CMOS, Pull-low	N/A	On chip 1.8V regulator enable. Should be connected directly to pin 30 to enable regulators. Connect to ground to disable on chip VDDA1.8V and VDD1.8V regulators. If regulators are disabled, external 1.8V must be supplied to VDDA1.8 and VDD1.8 pins.
32	RBIAS	Analog, CMOS	N/A	External 12K Ω +/- 1% bias resistor to ground.
	GND FLAG	Ground	N/A	Ground. The flag must be connected to the ground plane with a via array under the exposed flag. This is the main ground for the IC.

Chapter 4 Operational Description

Table 4.1 Maximum Guaranteed Ratings

PARAMETER	SYMBOL	CONDITIONS	MIN	TYP	MAX	UNITS
Maximum VBUS, ID, EXTVBUS, DP, and DM voltage to GND	V_{MAX_5V}		-0.5		+5.5	V
Maximum VDD1.8 and VDDA1.8 voltage to Ground	$V_{MAX_1.8V}$		-0.5		2.5	V
Maximum 3.3V supply voltage to Ground	$V_{MAX_3.3V}$		-0.5		4.0	V
Maximum I/O voltage to Ground	V_{MAX_IN}		-0.5		4.0	V
Operating Temperature	T_{MAX_OP}		-40		85	°C
Storage Temperature	T_{MAX_STG}		-55		150	°C
ESD PERFORMANCE						
All Pins	V_{HBM}	Human Body Model	±8			kV
LATCH-UP PERFORMANCE						
All Pins	I_{LTCH_UP}	EIA/JESD 78, Class II	150			mA

Note: Stresses beyond those listed under “Absolute Maximum Ratings” may cause permanent damage to the device. Exposure to absolute maximum rating conditions for extended periods may affect device reliability.

Table 4.2 Recommended Operating Conditions

PARAMETER	SYMBOL	CONDITIONS	MIN	TYP	MAX	UNITS
VDD3.3 to GND	$V_{DD3.3}$		3.0	3.3	3.6	V
Input Voltage on Digital Pins	V_I		0.0		$V_{DD3.3}$	V
Voltage on Analog I/O Pins (DP, DM, ID)	$V_{I(I/O)}$		0.0		$V_{DD3.3}$	V
VBUS to GND	V_{VBUS}		0.0		5.25	
Ambient Temperature	T_A		-40		85	C

Chapter 5 Electrical Characteristics

Table 5.1 Electrical Characteristics: Supply Pins

PARAMETER	SYMBOL	CONDITIONS	TYP	MAX	UNITS
Unconfigured Current	$I_{AVG(UCFG)}$	Device Unconfigured	Same as Idle		mA
FS Idle 3.3V Current	$I_{AVG(FS33)}$	FS idle not data transfer	18.8	21.9	mA
FS Idle 1.8V Current	$I_{AVG(FS18)}$	FS idle not data transfer	36.4	43.2	mA
FS Transmit 3.3V Current	$I_{AVG(FSTX33)}$	FS current during data transmit	36.0	41.6	mA
FS Transmit 1.8V Current	$I_{AVG(FSTX18)}$	FS current during data transmit	36.8	43.2	mA
FS Receive 3.3V Current	$I_{AVG(FSRX33)}$	FS current during data receive	22.5	27.0	mA
FS Receive 1.8V Current	$I_{AVG(FSRX18)}$	FS current during data receive	36.7	43.4	mA
HS Idle 3.3V Current	$I_{AVG(HS33)}$	HS idle not data transfer	22.1	25.4	mA
HS Idle 1.8V Current	$I_{AVG(HS18)}$	HS idle not data transfer	38.7	45.6	mA
HS Transmit 3.3V Current	$I_{AVG(HSTX33)}$	HS current during data transmit	25.4	29.0	mA
HS Transmit 1.8V Current	$I_{AVG(HSTX18)}$	HS current during data transmit	39.1	46.2	mA
HS Receive 3.3V Current	$I_{AVG(HSRX33)}$	HS current during data receive	23.0	26.6	mA
HS Receive 1.8V Current	$I_{AVG(HSRX18)}$	HS current during data receive	39.6	46.8	mA
Low Power Mode 3.3V Current	$I_{DD(LPM33)}$	VBUS 15k Ω pull-down and 1.5k Ω pull-up resistor currents not included.	59.4		μ A
Low Power Mode 1.8V Current	$I_{DD(LPM18)}$	VBUS 15k Ω pull-down and 1.5k Ω pull-up resistor currents not included.	25.5		μ A

Notes:

- $V_{DD3.3} = 3.0$ to $3.6V$; $V_{SS} = 0V$; $T_A = -40C$ to $+85C$; unless otherwise specified.
- SessEnd and VbusVld comparators disabled. Interface protection disabled.
- Maximum current numbers are worst case over supply voltage, temperature and process.

Table 5.2 Electrical Characteristics: CLKOUT Start-Up

PARAMETER	SYMBOL	CONDITIONS	MIN	TYP	MAX	UNITS
Suspend Recovery Time	T_{START}			2.25	3.5	ms

Note: The USB330 uses the *AutoResume* feature, [Section 6.3](#), for host start-up of less than 1ms

Table 5.3 DC Electrical Characteristics: Logic Pins

PARAMETER	SYMBOL	CONDITIONS	MIN	TYP	MAX	UNITS
Low-Level Input Voltage	V_{IL}		V_{SS}		0.8	V
High-Level Input Voltage	V_{IH}		2.0		$V_{DD3.3}$	V
Low-Level Output Voltage	V_{OL}	$I_{OL} = 8\text{mA}$			0.4	V
High-Level Output Voltage	V_{OH}	$I_{OH} = -8\text{mA}$	$V_{DD3.3} - 0.4$			V
Input Leakage Current	I_{LI}				±10	uA
Pin Capacitance	C_{pin}				4	pF

Note: $V_{DD3.3} = 3.0$ to 3.6V ; $V_{SS} = 0\text{V}$; $T_A = -40\text{C}$ to $+85\text{C}$; unless otherwise specified.

Table 5.4 DC Electrical Characteristics: Analog I/O Pins (DP/DM)

PARAMETER	SYMBOL	CONDITIONS	MIN	TYP	MAX	UNITS
FS FUNCTIONALITY						
Input levels						
Differential Receiver Input Sensitivity	V_{DIFS}	$ V(DP) - V(DM) $	0.2			V
Differential Receiver Common-Mode Voltage	V_{CMFS}		0.8		2.5	V
Single-Ended Receiver Low Level Input Voltage	V_{ILSE}				0.8	V
Single-Ended Receiver High Level Input Voltage	V_{IHSE}		2.0			V
Single-Ended Receiver Hysteresis	V_{HYSSE}		0.050		0.150	V
Output Levels						
Low Level Output Voltage	V_{FSOL}	Pull-up resistor on DP; $R_L = 1.5\text{k}\Omega$ to $V_{DD3.3}$			0.3	V
High Level Output Voltage	V_{FSOH}	Pull-down resistor on DP, DM; $R_L = 15\text{k}\Omega$ to GND	2.8		3.6	V
Termination						
Driver Output Impedance for HS and FS	Z_{HSDRV}	Steady state drive	40.5	45	49.5	Ω
Input Impedance	Z_{INP}	TX, RPU disabled	1.0			MΩ
Pull-up Resistor Impedance	Z_{PU}	Bus Idle	0.900	1.24	1.575	kΩ
Pull-up Resistor Impedance	Z_{PURX}	Device Receiving	1.425	2.26	3.09	kΩ
Pull-dn Resistor Impedance	Z_{PD}		14.25	15.0	15.75	kΩ

Table 5.4 DC Electrical Characteristics: Analog I/O Pins (DP/DM) (continued)

PARAMETER	SYMBOL	CONDITIONS	MIN	TYP	MAX	UNITS
HS FUNCTIONALITY						
Input levels						
HS Differential Input Sensitivity	V_{DIHS}	$ V(DP) - V(DM) $	100			mV
HS Data Signaling Common Mode Voltage Range	V_{CMHS}		-50		500	mV
HS Squelch Detection Threshold (Differential)	V_{HSSQ}	Squelch Threshold			100	mV
		Un-squelch Threshold	150			mV
Output Levels						
Hi-Speed Low Level Output Voltage (DP/DM referenced to GND)	V_{HSOL}	45 Ω load	-10		10	mV
Hi-Speed High Level Output Voltage (DP/DM referenced to GND)	V_{HSOH}	45 Ω load	360		440	mV
Hi-Speed IDLE Level Output Voltage (DP/DM referenced to GND)	V_{OLHS}	45 Ω load	-10		10	mV
Chirp-J Output Voltage (Differential)	V_{CHIRPJ}	HS termination resistor disabled, pull-up resistor connected. 45 Ω load.	700		1100	mV
Chirp-K Output Voltage (Differential)	V_{CHIRPK}	HS termination resistor disabled, pull-up resistor connected. 45 Ω load.	-900		-500	mV
Leakage Current						
OFF-State Leakage Current	I_{LZ}				± 10	μA
Port Capacitance						
Transceiver Input Capacitance	C_{IN}	Pin to GND		5	10	pF

Note: $V_{DD3.3} = 3.0$ to $3.6V$; $V_{SS} = 0V$; $T_A = -40C$ to $+85C$; unless otherwise specified.

Table 5.5 Dynamic Characteristics: Analog I/O Pins (DP/DM)

PARAMETER	SYMBOL	CONDITIONS	MIN	TYP	MAX	UNITS
FS Output Driver Timing						
Rise Time	T_{FSR}	$C_L = 50pF$; 10 to 90% of $ V_{OH} - V_{OL} $	4		20	ns
Fall Time	T_{FFF}	$C_L = 50pF$; 10 to 90% of $ V_{OH} - V_{OL} $	4		20	ns
Output Signal Crossover Voltage	V_{CRS}	Excluding the first transition from IDLE state	1.3		2.0	V

Table 5.5 Dynamic Characteristics: Analog I/O Pins (DP/DM) (continued)

PARAMETER	SYMBOL	CONDITIONS	MIN	TYP	MAX	UNITS
Differential Rise/Fall Time Matching	FRFM	Excluding the first transition from IDLE state	90		111.1	%
HS Output Driver Timing						
Differential Rise Time	T _{HSR}		500			ps
Differential Fall Time	T _{HSF}		500			ps
Driver Waveform Requirements		Eye pattern of Template 1 in USB 2.0 specification				
Hi-Speed Mode Timing						
Receiver Waveform Requirements		Eye pattern of Template 4 in USB 2.0 specification				
Data Source Jitter and Receiver Jitter Tolerance		Eye pattern of Template 4 in USB 2.0 specification				

Note: V_{DD3.3} = 3.0 to 3.6V; V_{SS} = 0V; T_A = -40C to +85C; unless otherwise specified.

Table 5.6 OTG Electrical Characteristics

PARAMETER	SYMBOL	CONDITIONS	MIN	TYP	MAX	UNITS
SessEnd trip point	V _{SessEnd}		0.2	0.5	0.8	V
SessVld trip point	V _{SessVld}		0.8	1.4	2.0	V
VBUSVld trip point	V _{VbusVld}		4.4	4.58	4.75	V
Vbus Pull-Up	R _{VbusPu}	Vbus to VDD3.3 (ChargeVbus = 1)	281	340		Ω
Vbus Pull-down	R _{VbusPd}	Vbus to GND (DisChargeVbus = 1)	656	850		Ω
Vbus Impedance	R _{Vbus}	Vbus to GND	40	75	100	kΩ
ID pull-up resistance	R _{IdPullUp}	IdPullup = 1	80	100	120	kΩ
ID pull-up resistance	R _{Id}	IdPullup = 0	1			MΩ
STP pull-up resistance	R _{STP}	InterfaceProtectDisable = 0	240	330	600	kΩ

Note: V_{DD3.3} = 3.0 to 3.6V; V_{SS} = 0V; T_A = -40C to +85C; unless otherwise specified

Table 5.7 Regulator Output Voltages

PARAMETER	SYMBOL	CONDITIONS	MIN	TYP	MAX	UNITS
V _{DDA1.8}	V _{DDA1.8}	Normal Operation (SuspendM = 1)	1.6	1.8	2.0	V
V _{DDA1.8}	V _{DDA1.8}	Low Power Mode (SuspendM = 0)		0		V
V _{DD1.8}	V _{DD1.8}		1.6	1.8	2.0	V

Note: V_{DD3.3} = 3.0 to 3.6V; V_{SS} = 0V; T_A = -40C to +85C; unless otherwise specified

Chapter 6 Architecture Overview

The USB3300 architecture can be broken down into the following blocks shown in [Figure 6.1](#) below.

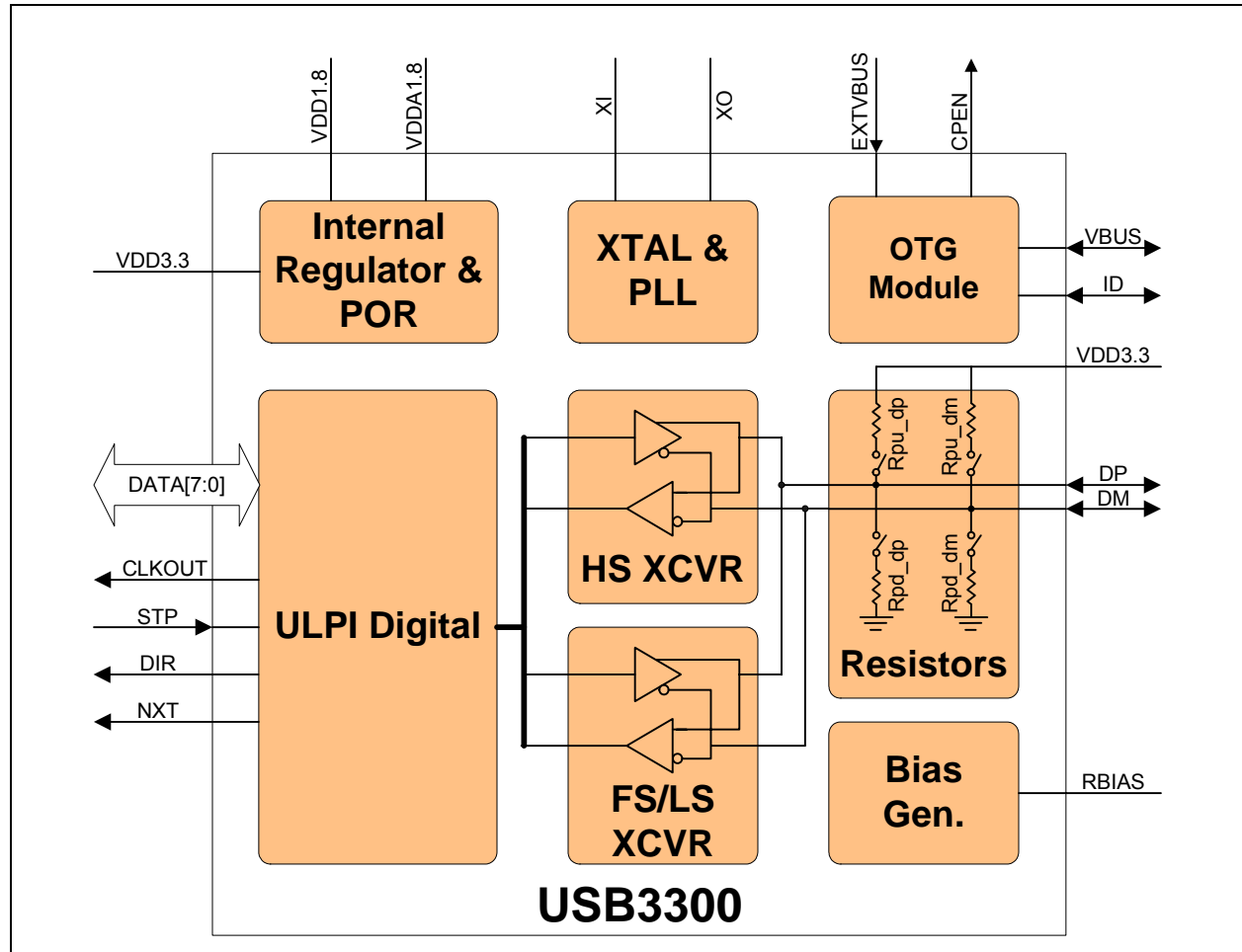

Figure 6.1 Simplified USB3300 Architecture

6.1 ULPI Digital

The USB3300 uses the industry standard ULPI digital interface to facilitate communication between the PHY and Link (device controller). The ULPI interface is designed to reduce the number of pins required to connect a discrete USB PHY to an ASIC or digital controller. For example, a full UTMI+ Level 3 OTG interface requires 54 signals while a ULPI interface requires only 12 signals.

The ULPI interface is documented completely in the “UTMI+ Low Pin Interface (ULPI) Specification” document (www.ulpi.org). The following sections highlight the key operating modes of the USB3300 digital interface.

6.1.1 Overview

[Figure 6.2](#) illustrates the block diagram of the ULPI digital functions. It should be noted that this PHY does not use a “ULPI wrapper” around a UTMI+ PHY core as the ULPI specification implies.

The advantage of a “wrapper less” architecture is that the PHY has a lower USB latency than a design which must first register signals into the PHY’s wrapper before the transfer to the PHY core. A low latency PHY allows a Link to use a wrapper around a UTMI Link and still make the required USB turn-around timing given in the USB 2.0 specification.

RxEndDelay maximum allowed by the UTMI+/ULPI for 8-bit data is 63 high speed clocks. USB3300 uses a low latency high speed receiver path to lower the RxEndDelay to 43 high speed clocks. This low latency design gives the Link more cycles to make decisions and reduces the Link complexity. This is the result of the “wrapper less” architecture of the USB3300. This low RxEndDelay should allow legacy UTMI Links to use a “wrapper” to convert the UTMI+ interface to a ULPI interface.

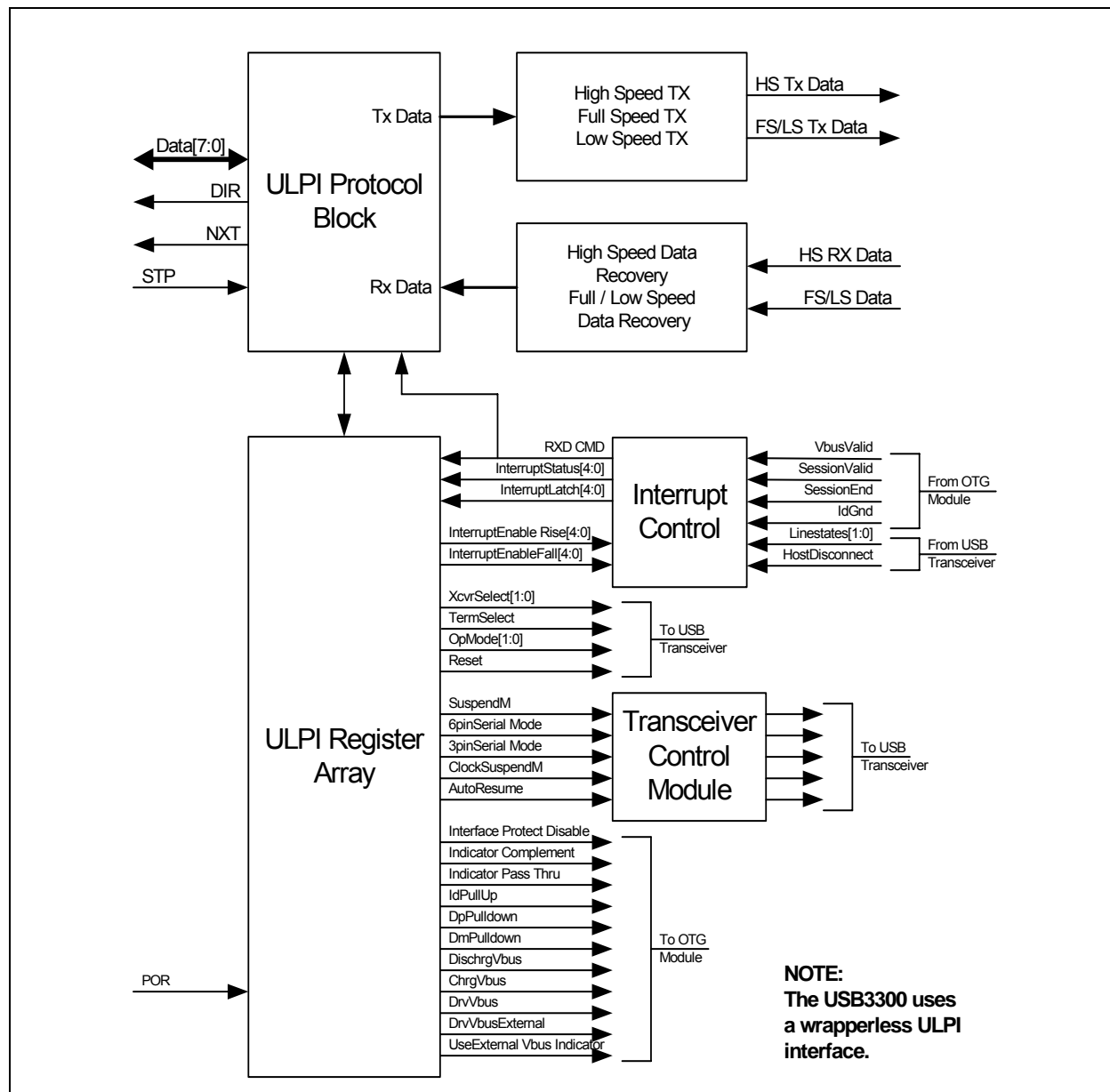

Figure 6.2 ULPI Digital Block Diagram

In Figure 6.2, a single ULPI Protocol Block decodes the ULPI 8-bit bi-directional bus when the Link addresses the PHY. The Link must use the DIR output to determine direction of the ULPI data bus. The USB3300 is the “bus arbitrator”. The ULPI Protocol Block will route data/commands to the transmitter or the ULPI register array.

6.1.2 ULPI Interface Signals

UTMI+ Low Pin Interface (ULPI) uses 12-pins to connect a full OTG Host / Device PHY to an SOC. A reduction of external pins on the PHY is accomplished by realizing that many of the relatively static configuration pins (xvcrselect[1:0], termselect, opmode[1:0], and DpPullDown DmPullDown to list a few,) can be implemented by having a internal static register array.

An 8-bit bi-directional data bus clocked at 60Mhz allows the Link to access this internal register array and transfer USB packets to and from the PHY. The remaining 3 pins function to control the data flow and arbitrate the data bus.

Direction of the 8-bit data bus is control by the DIR output from the PHY. Another output NXT is used to control data flow into and out of the device. Finally, STP, which is in input to the PHY, terminates transfers and is used to start up and resume from a suspend state.

The 12 signals are described below in [Table 6.1](#).

Table 6.1 ULPI Interface Signals

SIGNAL	DIRECTION	DESCRIPTION
CLKOUT	OUT	60MHz reference clock output. All ULPI signals are driven synchronous to the rising edge of this clock.
DATA[7:0]	I/O	8-bit bi-directional data bus. Bus ownership is determined by DIR. The Link and PHY initiate data transfers by driving a non-zero pattern onto the data bus. ULPI defines interface timing for a single-edge data transfers with respect to rising edge of CLKOUT.
DIR	OUT	Controls the direction of the data bus. When the PHY has data to transfer to the Link, it drives DIR high to take ownership of the bus. When the PHY has no data to transfer it drives DIR low and monitors the bus for commands from the Link. The PHY will pull DIR high whenever the interface cannot accept data from the Link, such as during PLL start-up.
STP	IN	The Link asserts STP for one clock cycle to stop the data stream currently on the bus. If the Link is sending data to the PHY, STP indicates the last byte of data was on the bus in the previous cycle.
NXT	OUT	The PHY asserts NXT to throttle the data. When the Link is sending data to the PHY, NXT indicates when the current byte has been accepted by the PHY. The Link places the next byte on the data bus in the following clock cycle.

USB3300 implements a Single Data Rate (SDR) ULPI interface with all data transfers happening on the rising edge of the CLKOUT. CLKOUT is supplied by the PHY.

The ULPI interface supports the two basic modes of operation, Synchronous Mode and Low Power Mode. Synchronous Mode with the signals all changing relative to the 60MHz clockout. Low Power Mode where the clock is off in a suspended state and the lower two bits of the data bus contain the linestate[1:0] signals. ULPI adds to Low Power Mode, an interrupt output which permits the Link to receive an asynchronous interrupt when the OTG comparators, or ID pin change state.

In Synchronous Mode operation, data is transferred on the rising edge of CLKOUT. Direction of the data bus is determined by the state of DIR. When DIR is high, the PHY is driving DATA[7:0]. When DIR is low, the Link is driving DATA[7:0].

Each time DIR changes, a “turn-around” cycle occurs where neither the Link nor PHY drive the data bus for one clock cycle. During the “turn-around” cycle, the state of DATA[7:0] is unknown and the PHY will not read the data bus.

Because USB uses a bit-stuffing encoding, some means of allowing the PHY to throttle the USB transmit data is needed. The ULPI signal NXT is used to request the next byte to be placed on the databus by the Link layer.

6.1.3 ULPI Interface Timing

The control and data timing relationships are given in [Figure 6.3](#) and [Table 6.2](#). The USB300 PHY provides CLKOUT and all timing is relative to the rising clock edge. The timing relationships detailed below apply to Synchronous Mode only.

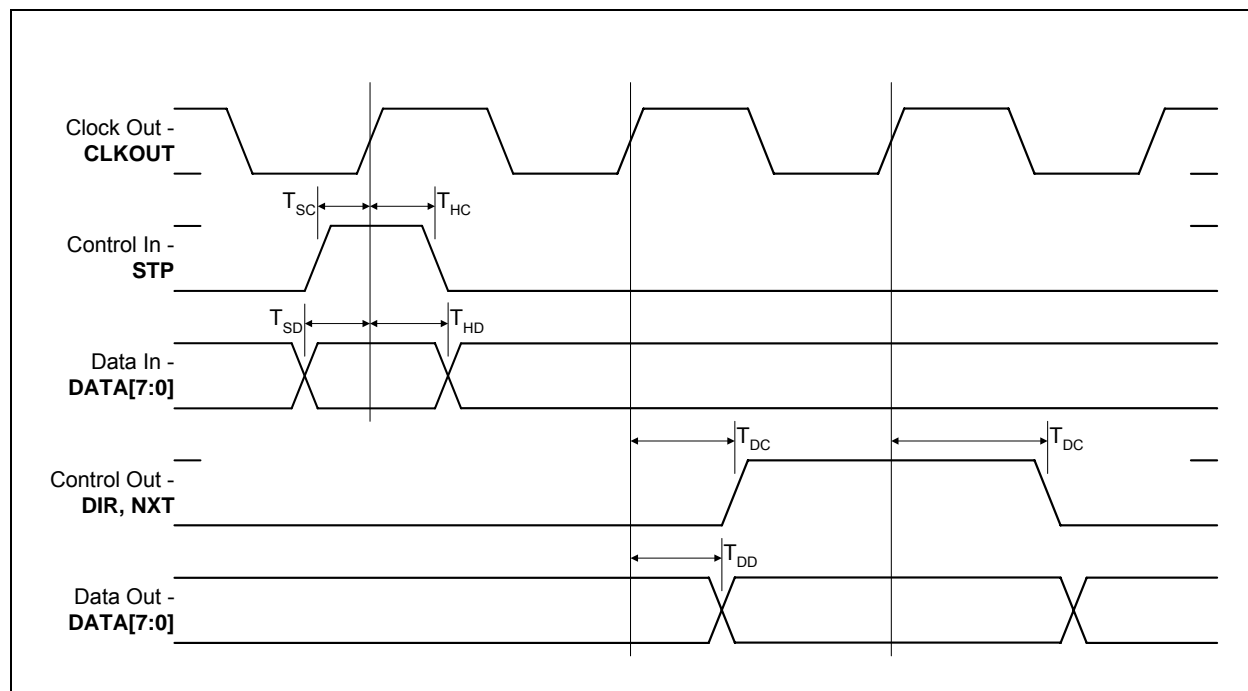

Figure 6.3 ULPI Timing Diagram

Table 6.2 ULPI Interface Timing

PARAMETER	SYMBOL	MIN	MAX	UNITS
Setup time (control in, 8-bit data in)	T_{SC}, T_{SD}	5.0		ns
Hold time (control in, 8-bit data in)	T_{HC}, T_{HD}	0		ns
Output delay (control out, 8-bit data out)	T_{DC}, T_{DD}	2.0	5.0	ns

Note: $V_{DD3.3} = 3.0$ to $3.6V$; $V_{SS} = 0V$; $T_A = -40C$ to $85C$; unless otherwise specified.

6.1.4 ULPI Register Array

The USB3300 PHY implements all of the ULPI registers detailed in the ULPI revision 1.1 specification. The complete USB3300 ULPI register set is shown in [Table 6.3](#). All registers are 8 bits. This table also includes the default states of the register upon POR. The RESET bit in the Function Control Register does not reset the bits of the ULPI register array. The Link should not read or write to any registers not listed in this table.

Table 6.3 ULPI Register Map

REGISTER NAME	DEFAULT STATE	ADDRESS (6BIT)			
		READ	WRITE	SET	CLEAR
Vendor ID Low	24h	00h	-	-	-
Vendor ID High	04h	01h	-	-	-
Product ID Low	04h	02h	-	-	-
Product ID High	00h	03h	-	-	-
Function Control	41h	04-06h	04h	05h	06h
Interface Control	00h	07-09h	07h	08h	09h
OTG Control	06h	0A-0Ch	0Ah	0Bh	0Ch
USB Interrupt Enable Rising	1Fh	0D-0Fh	0Dh	0Eh	0Fh
USB Interrupt Enable Falling	1Fh	10-12h	10h	11h	12h
USB Interrupt Status	00h	13h	-	-	-
USB Interrupt Latch	00h	14h	-	-	-
Debug	00h	15h	-	-	-
Scratch Register	00h	16-18h	16h	17h	18h

6.1.4.1 Vendor ID Low: Address = 00h (read only)

FIELD NAME	BIT	DEFAULT	DESCRIPTION
Vendor ID Low	7:0	24h	SMSC Vendor ID

6.1.4.2 Vendor ID High: Address = 01h (read only)

FIELD NAME	BIT	DEFAULT	DESCRIPTION
Vendor ID High	7:0	04h	SMSC Vendor ID

6.1.4.3 Product ID Low: Address = 02h (read only)

FIELD NAME	BIT	DEFAULT	DESCRIPTION
Product ID Low	7:0	04h	SMSC Product ID revision A0

6.1.4.4 Vendor ID Low: Address = 03h (read only)

FIELD NAME	BIT	DEFAULT	DESCRIPTION
Product ID High	7:0	00h	SMSC Product ID revision A0

6.1.4.5 Function Control: Address = 04-06h (read), 04h (write), 05h (set), 06h (clear)

FIELD NAME	BIT	DEFAULT	DESCRIPTION
XcvrSelect[1:0]	1:0	01b	Selects the required transceiver speed. 00b: Enables HS transceiver 01b: Enables FS transceiver 10b: Enables LS transceiver 11b: Enables FS transceiver for LS packets (FS preamble automatically pre-pended)
TermSelect	2	0b	Controls the DP and DM termination depending on XcvrSelect, OpMode, DpPulldown, and DmPulldown. The Dp and DM termination is detailed in Table 6.8 .
OpMode	4:3	00b	Selects the required bit encoding style during transmit. 00b: Normal Operation 01b: Non-Driving 10b: Disable bit-stuff and NRZI encoding 11b: Reserved
Reset	5	0b	Active high transceiver reset. This reset does not reset the ULPI interface or register set. Automatically clears after reset is complete.
SuspendM	6	1b	Active low PHY suspend. When cleared the PHY will enter Low Power Mode as detailed in 6.1.9 . Automatically set when exiting Low Power Mode.
Reserved	7	0b	Driven low.

Datasheet

6.1.4.6 Interface Control: Address = 07-09h (read), 07h (write), 08h (set), 09h (clear)

FIELD NAME	BIT	DEFAULT	DESCRIPTION
6-pin FsLsSerialMode	0	0b	Changes the ULPI interface to a 6-pin Serial Mode. The PHY will automatically clear this bit when exiting serial mode.
3-pin FsLsSerialMode	1	0b	Changes the ULPI interface to a 3-pin Serial Mode. The PHY will automatically clear this bit when exiting serial mode.
Reserved	2	0b	Driven low.
ClockSuspendM	3	0b	Enables Link to turn on 60MHz CLKOUT in serial mode. 0b: Disable clock in serial mode. 1b: Enable clock in serial mode.
AutoResume	4	0b	Only applicable in Host mode. Enables the PHY to automatically transmit resume signaling. This function is detailed in Section 6.1.7.4 .
IndicatorComplement	5	0b	Inverts the EXTVBUS signal. This function is detailed in Section 6.5.4 .
IndicatorPassThru	6	0b	Disables anding the internal VBUS comparator with the EXTVBUS input when asserted. This function is detailed in Section 6.5.4 .
InterfaceProtectDisable	7	0b	Used to disable the integrated STP pull-up resistor used for interface protection. This function is detailed in Section 6.1.9.3 .

6.1.4.7 OTG Control: Address = 0A-0Ch (read), 0Ah (write), 0Bh (set), 0Ch (clear)

FIELD NAME	BIT	DEFAULT	DESCRIPTION
IdPullup	0	0b	Connects a pull-up resistor from the ID pin to VDD3.3 0b: Disables the pull-up resistor 1b: Enables the pull-up resistor
DpPulldown	1	1b	Enables the 15k Ohm pull-down resistor on DP. 0b: Pull-down resistor not connected to DP 1b: Pull-down resistor connected to DP
DmPulldown	2	1b	Enables the 15k Ohm pull-down resistor on DM. 0b: Pull-down resistor not connected to DM 1b: Pull-down resistor connected to DM
DischrgVbus	3	0b	This bit is only used during SRP. Connects a resistor from VBUS to ground to discharge VBUS. 0b: disconnect resistor from VBUS to ground 1b: connect resistor from VBUS to ground
ChrgVbus	4	0b	This bit is only used during SRP. Connects a resistor from VBUS to VDD3.3 to charge VBUS above the SessValid threshold. 0b: disconnect resistor from VBUS to VDD3.3 1b: connect resistor from VBUS to VDD3.3

FIELD NAME	BIT	DEFAULT	DESCRIPTION
DrvVbus	5	0b	Used to enable external 5 volt supply to drive 5 volts on VBUS. This signal is or'ed with DrvVbusExternal. 0b: do not drive VBUS 1b: drive VBUS
DrvVbusExternal	6	0b	Used to enable external 5 volt supply to drive 5 volts on VBUS. This signal is or'ed with DrvVbus. 0b: do not drive VBUS 1b: drive VBUS
UseExternalVbus Indicator	7	0b	Tells the PHY to use an external VBUS over-current or voltage indicator. This function is detailed in Section 6.5.4 . 0b: Use the internal VbusValid comparator 1b: Use the EXTVBUS input as for VbusValid signal.

6.1.4.8 USB Interrupt Enable Rising: Address = 0D-0Fh (read), 0Dh (write), 0Eh (set), 0Fh (clear)

FIELD NAME	BIT	DEFAULT	DESCRIPTION
HostDisconnect Rise	0	1b	Generate an interrupt event notification when Hostdisconnect changes from low to high. Applicable only in host mode.
VbusValid Rise	1	1b	Generate an interrupt event notification when Vbusvalid changes from low to high.
SessValid Rise	2	1b	Generate an interrupt event notification when SessValid changes from low to high.
SessEnd Rise	3	1b	Generate an interrupt event notification when SessEnd changes from low to high.
IdGnd Rise	4	1b	Generate an interrupt event notification when IdGnd changes from low to high.
Reserved	7:5	0h	Driven low.

6.1.4.9 USB Interrupt Enable Falling: Address = 10-12h (read), 10h (write), 11h (set), 12h (clear)

FIELD NAME	BIT	DEFAULT	DESCRIPTION
HostDisconnect Fall	0	1b	Generate an interrupt event notification when Hostdisconnect changes from high to low. Applicable only in host mode.
VbusValid Fall	1	1b	Generate an interrupt event notification when Vbusvalid changes from high to low.
SessValid Fall	2	1b	Generate an interrupt event notification when SessValid changes from high to low.

Datasheet

FIELD NAME	BIT	DEFAULT	DESCRIPTION
SessEnd Fall	3	1b	Generate an interrupt event notification when SessEnd changes from high to low.
IdGnd Fall	4	1b	Generate an interrupt event notification when IdGnd changes from high to low.
Reserved	7:5	0h	Driven low.

6.1.4.10 USB Interrupt Status Register: Address = 13h (read only with auto clear)

FIELD NAME	BIT	DEFAULT	DESCRIPTION
HostDisconnect	0	0b	Current value of the UTMI+ Hostdisconnect output. Applicable only in host mode.
VbusValid	1	0b	Current value of the UTMI+ Vbusvalid output.
SessValid	2	0b	Current value of the UTMI+ SessValid output.
SessEnd	3	0b	Current value of the UTMI+ SessEnd output.
IdGnd	4	0b	Current value of the UTMI+ IdGnd output.
Reserved	7:5	0h	Driven low.

6.1.4.11 USB Interrupt Status: Address = 14h (read only with auto clear)

FIELD NAME	BIT	DEFAULT	DESCRIPTION
HostDisconnect Latch	0	0b	Set to 1b by the PHY when an unmasked event occurs on Hostdisconnect. Cleared when this register is read. Applicable only in host mode.
VbusValid Latch	1	0b	Set to 1b by the PHY when an unmasked event occurs on VbusValid. Cleared when this register is read.
SessValid Latch	2	0b	Set to 1b by the PHY when an unmasked event occurs on SessValid. Cleared when this register is read.
SessEnd Latch	3	0b	Set to 1b by the PHY when an unmasked event occurs on SessEnd. Cleared when this register is read.
IdGnd Latch	4	0b	Set to 1b by the PHY when an unmasked event occurs on IdGnd. Cleared when this register is read.
Reserved	7:5	0h	Driven low.

6.1.4.12 Debug Register: Address = 15h (read only)

FIELD NAME	BIT	DEFAULT	DESCRIPTION
Linestate0	0	0b	Contains the current value of Linestate[0].
Linestate1	1	0b	Contains the current value of Linestate[1].
Reserved	7:2	000000b	Driven low.

6.1.4.13 Scratch Register: Address = 16-18h (read), 16h (write), 17h (set), 18h (clear)

FIELD NAME	BIT	DEFAULT	DESCRIPTION
Scratch	7:0	00h	Empty register byte for testing purposes. Software can read, write, set, and clear this register and the PHY functionality will not be affected.

6.1.4.14 Carkit Register Access

The Carkit registers are reserved for SMSC testing and should not be written to or read by the Link.

6.1.4.15 Extended Register Access

The extended registers are reserved for SMSC testing and should not be written to or read by the Link.

6.1.4.16 Vendor Register Access

The vendor specific registers are reserved for SMSC testing and should not be written to or read by the Link. The vendor specific registers include the range from 30h to 3Fh.

6.1.5 ULPI Register Access

A command from the Link begins a ULPI transfer from the Link to the USB3300. Anytime the Link wants to write or read a ULPI register, the Link will need to wait until DIR is low, and then send a Transmit Command Byte (TXD CMD) to the PHY. The TXD CMD byte informs the PHY of the type of data being sent. The TXD CMD is followed by the a data transfer to or from the PHY. [Table 6.4](#) gives the TXD command byte (TXD CMD) encoding for the USB3300. The upper two bits of the TX CMD instruct the PHY as to what type of packet the Link is transmitting.

Table 6.4 ULPI TXD CMD Byte Encoding

COMMAND NAME	CMD BITS[7:6]	CMD BITS[5:0]	COMMAND DESCRIPTION
Idle	00b	000000b	ULPI Idle
Transmit	01b	000000b	USB Transmit Packet with No Packet Identifier (NOPID)
		00XXXXb	USB Transmit Packet Identifier (PID) where DATA[3:0] is equal to the 4-bit PID. P ₃ P ₂ P ₁ P ₀ where P ₃ is the MSB.

Table 6.4 ULPI TXD CMD Byte Encoding (continued)

COMMAND NAME	CMD BITS[7:6]	CMD BITS[5:0]	COMMAND DESCRIPTION
Register Write	10b	XXXXXXb	Immediate Register Write Command where DATA[5:0] = 6-bit register address
Register Read	11b	XXXXXXb	Immediate Register Read Command where DATA[5:0] = 6-bit register address

6.1.5.1 ULPI Register Write

A ULPI register write operation is given in Figure 6.4. The TXD command with a register write DATA[7:6] = 10b is driven by the Link at T0. The register address is encoded into DATA[5:0] of the TXD CMD byte.

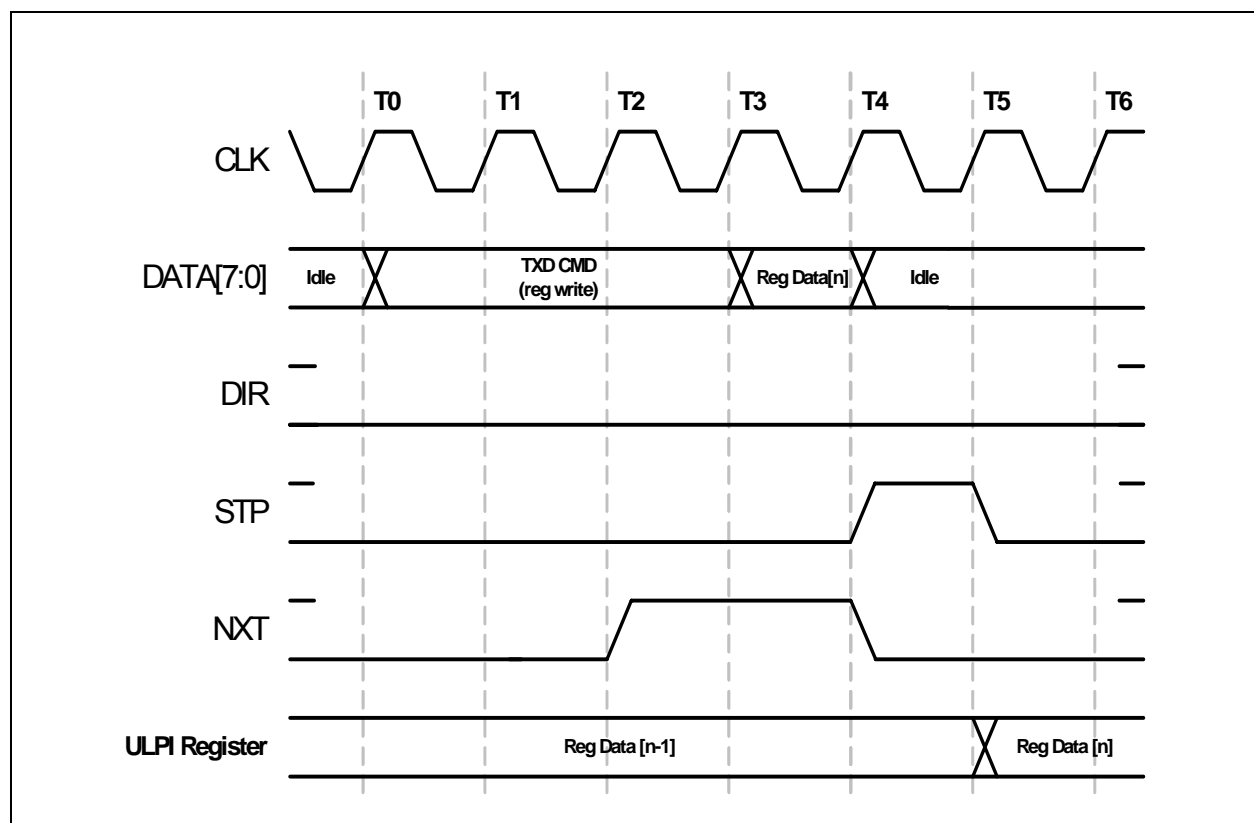
**Figure 6.4 ULPI Register Write**

To write to a register, the Link will wait until DIR is low, and at T0, drive the TXD CMD on the databus. At T2 the PHY will drive NXT high. On the next rising clock edge, T3, the Link will write the register data. At T4 the PHY will accept the register data and the Link will drive an Idle on the bus and drive STP high to signal the end of the data packet. Finally, at T5, the PHY will latch the data into the register and drive NXT low. The Link will pull STP low.

NXT is used to control when the Link drives the register data on the bus. DIR is low throughout this transaction since the PHY is receiving data from the Link. STP is used to end the transaction and data is registered after the de-assertion of STP. After the write operation completes, the Link must drive a ULPI Idle (00h) on the data bus or the USB3300 may decode the bus value as a ULPI command.

6.1.5.2 ULPI Register Read

A ULPI register read operation is given in [Figure 6.5](#). The Link drives a TXD CMD byte with DATA[7:6] = 1h for a register read. DATA[5:0] of the ULPI TXD command byte contain the register address.

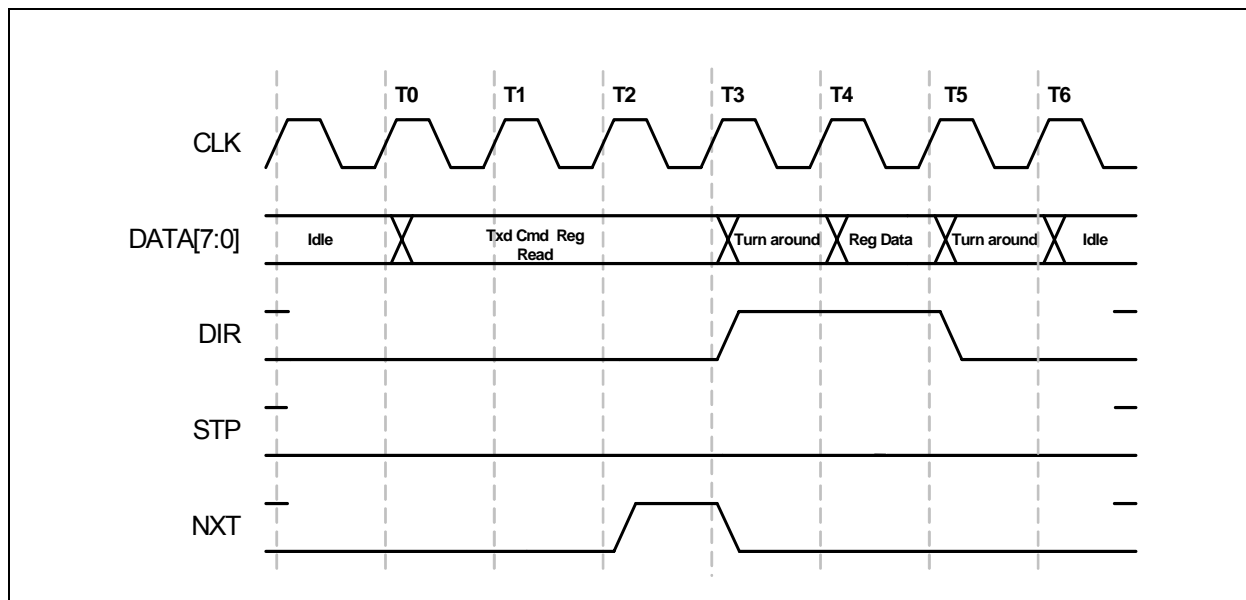

Figure 6.5 ULPI Register Read

At T0, the Link will place the TXD CMD on the databus. At T2, the PHY will bring NXT high, signaling that the Link it is ready to accept the data transfer. At T3, the PHY reads the TXD CMD, determines it is a register read, and asserts DIR to gain control of the bus. The PHY will also de-assert NXT. At T4, the bus ownership has transferred back to the PHY and the PHY drives the requested register onto the databus. At T5, the Link will read the databus and the PHY will drop DIR low returning control of the bus back to the Link. After the turn around cycle, the Link must drive a ULPI Idle command at T6.

6.1.6 ULPI RXD CMD

The Link needs several more important states of information which were provided by the linestate[1:0], rxactive, rxvalid and rxerror. When an implementing the OTG functions the Vbus and ID pin states must also be transferred into the Link.

ULPI defines a Receive Command Byte (RXD CMD) that contains this information. The Encoding of the RXD CMD byte is given in the [Table 6.5](#).

Transfer of the RXD CMD byte occurs when in Synchronous Mode when the PHY has control of the bus. Transfers of the RXD CMD occur after: a transmit cmd has issued STP, a linestate change when not transmitting, a USB receive, or an interrupt event occurs.

In [Figure 6.2](#), the ULPI Protocol Block determines when to send an RXD CMD. When a linestate change occurs the RXD CMD is sent immediately if the DIR output is low.

When a USB Receive is occurring RXD CMDs are sent when ever NXT = 0 and DIR = 1. When a USB Transmit occurs the RXD CMDs are returned to the Link after the STP is asserted ending the Link to USB3300 transfer of the bytes to be sent on the transmit.

To summarize a RXD CMD transfer occurs:

- when DIR is low and a linestate change occurs.
- when Vbus and/or ID comparators change state.

Datasheet

- during a USB receive when NXT is low.
- after STP is asserted during a USB transmit cmd.

Table 6.5 ULPI RX CMD Encoding

DATA[7:0]	NAME	DESCRIPTION AND VALUE				
[1:0]	Linestate	UTMI Linestate Signals DATA[1] = Linestate[1] DATA[0] = Linestate[0]				
[3:2]	Encoded Vbus State	ENCODED VBUS VOLTAGE STATES				
		VALUE	VBUS VOLTAGE	SESEND	SESSVLD	VBUSVLD₂
		00	$V_{VBUS} < V_{SESS_END}$	1	0	0
		01	$V_{SESS_END} < V_{VBUS} < V_{SESS_VLD}$	0	0	0
		10	$V_{SESS_VLD} < V_{VBUS} < V_{VBUS_VLD}$	X	1	0
11	$V_{VBUS_VLD} < V_{VBUS}$	X	X	1		
[5:4]	Rx Event Encoding	ENCODED UTMI EVENT SIGNALS				
		VALUE	RXACTIVE	RXERROR	HOSTDISCONNECT	
		00	0	0	0	
		01	1	0	0	
		11	1	1	0	
10	X	X	1			
[6]	State of ID pin	Set to the logic state of the ID pin. A logic low indicates an A device. A logic high indicates a B device.				
[7]	Reserved	Always				

Notes:

1. An 'X' is a do not care and can be either a logic 0 or 1.
2. The value of VbusValid is defined in [Table 6.10](#).

6.1.7 USB3300 Transmitter

The USB3300 ULPI transmitter fully supports HS, FS, and LS transmit operations. [Figure 6.2](#) shows the high speed, full speed, and low speed transmitter block controlled by ULPI Protocol Block. Encoding of the USB packet follows the bit-stuffing and NRZI outlined in the USB 2.0 specification. Many of these functions are re-used between the high speed and full/low speed transmitters. When using the USB3300, [Table 6.8](#) should always be used as a guideline on how to configure for various modes of operation. The transmitter decodes the inputs of Xcvrselect, Termselect, opmodes, DpPulldown and DmPulldown to determine what operation is expected. Users must strictly adhere to the modes of operation given in [Table 6.8](#).

Several important functions for a device and host are designed in the transmitter blocks.

The USB3300 transmitter will transmit a 32-bit long high speed synch before every high speed packet. In full and low speed modes a 8-bit synch is transmitted.

When the device or host needs to chirp for high speed port negotiation, the Opmode Bits=10 will turn off the bit-stuffing and NRZI encoding in the transmitter. At the end of a chirp, the USB3300 Opmode register bits should be changed only after the RXCMD linestate encoding indicates that the transmitter has completed transmitting. Should the opmode be switched to normal bit-stuffing and NRZI encoding before the transmit pipeline is empty, the remaining data in the pipeline may be transmitted in an bit-stuff encoding format.

Please refer to the ULPI specification for a detailed discussion of USB reset and HS chirp.

6.1.7.1 High Speed Long EOP

When operating as a Hi-Speed host, the USB3300 will automatically generate a 40 bit long End of Packet (EOP) after a SOF PID (A5h). The USB3300 determines when to send the 40-bit long EOP by decoding the ULPI TXD CMD bits [3:0] for the SOF. The 40-bit long EOP is only transmitted when the DpPulldown and DmPulldown bits are asserted. The Hi-Speed 40-bit long EOP is used to detect a disconnect in high speed mode.

In device mode, the USB3300 will not send a long EOP after a SOF PID.

6.1.7.2 Low Speed Keep-Alive

Low speed keep alive is supported by the USB3300. When in Low speed (10b), the USB3300 will send out two Low speed bit times of SE0 when a SOF PID is received.

6.1.7.3 UTMI+ Level 3

Pre-amble is supported for UTMI+ Level 3 compatibility. When Xcvrselect is set to (11b) in host mode, (dpPulldown and dmPulldown both asserted) the USB3300 will pre-pend a full speed pre-amble before the low speed packet. Full speed rise and fall times are used in this mode. The pre-amble consists of the following: Full speed sync, the encoded pre-PID (C3h) and then full speed idle (DP=1 and DM = 0). A low speed packet follows with a sync, data and a LS EOP.

6.1.7.4 Host Resume K

Resume K generation is supported by the USB3300. When the USB3300 exits the suspended low power state, the USB3300, when operating as a host, will transmit a K on DP/DM. The transmitters will end the K with SE0 for two Low Speed bit times. If the USB3300 was operating in high speed mode before the suspend, the host must change to high speed mode before the SE0 ends. SE0 is two low speed bit times which is about 1.2 us.

The ULPI specification has an explicit discussion of the resume sequence and the order of operations required.

In device mode, the resume K will not append a SE0 but release the DP/ DM lines to allow the pull up to return the bus to the correct idle state, depending upon the operational mode of the USB3300. Refer to [Table 6.8](#).

6.1.7.5 No SYNC and EOP Generation (Opmode 11) (optional)

UTMI+ defines an opmode 11 where no sync and EOP generation occurs in Hi-Speed operation. This is an option to the ULPI specification and not implemented in the USB3300.

6.1.7.6 Typical USB Transmit with ULPI

[Figure 6.6](#) shows a typical USB transmit sequence. A transmit sequence starts by the Link sending a TXD CMD where DATA[7:6] = 01b, DATA[5:4] = 00b, and Data[3:0] = PID. The TX CMD with the PID is followed by transmit data. From the time the data is clocked into the transmitter it will appear at DP and DM 11 high speed bit times later. This time is the HS_TX_START_DELAY.

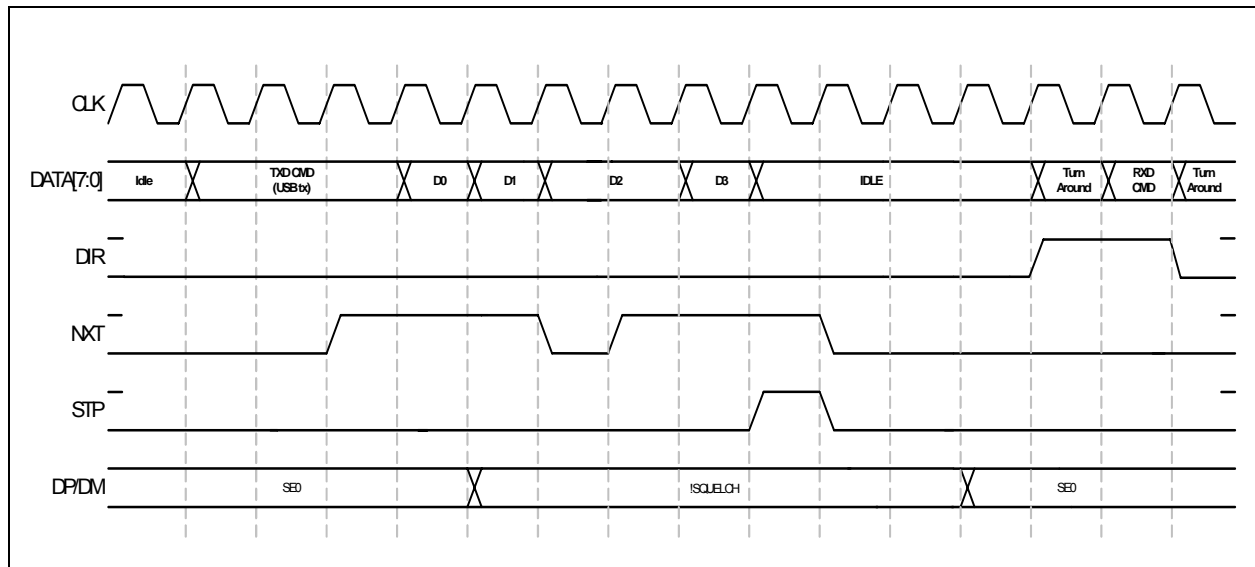

Figure 6.6 ULPI Transmit

During transmit the PHY will use NXT to control the rate of data flow into the PHY. If the USB3300 pipeline is full or bit-stuffing causes the data pipeline to overflow NXT is de-asserted and the Link will hold the value on Data until NXT is asserted. The USB Transmit ends when the Link asserts STP while NXT is asserted. (Note that the Link cannot assert STP with NXT de-asserted since the USB3300 is expecting to fetch another byte from the Link in this state).

Once, the USB3300 completes transmitting, the DP/DM lines return to idle and an RXD CMD is returned to the Link so the inter-packet timers may be updated by linestate.

In the case of Full Speed or Low Speed, once STP is asserted each FS/LS bit transition will generate a RXD CMD since the bit times are relatively slow.

6.1.8 USB3300 Receiver

The USB3300 ULPI receiver fully supports HS, FS, and LS transmit operations. In all three modes the receiver detects the start of packet and synchronizes to the incoming data packet. In the ULPI protocol, a received packet has the priority and will immediately follow register reads and RXD CMD transfers. [Figure 6.7](#) shows a basic USB packet received by the USB3300 over the ULPI interface.

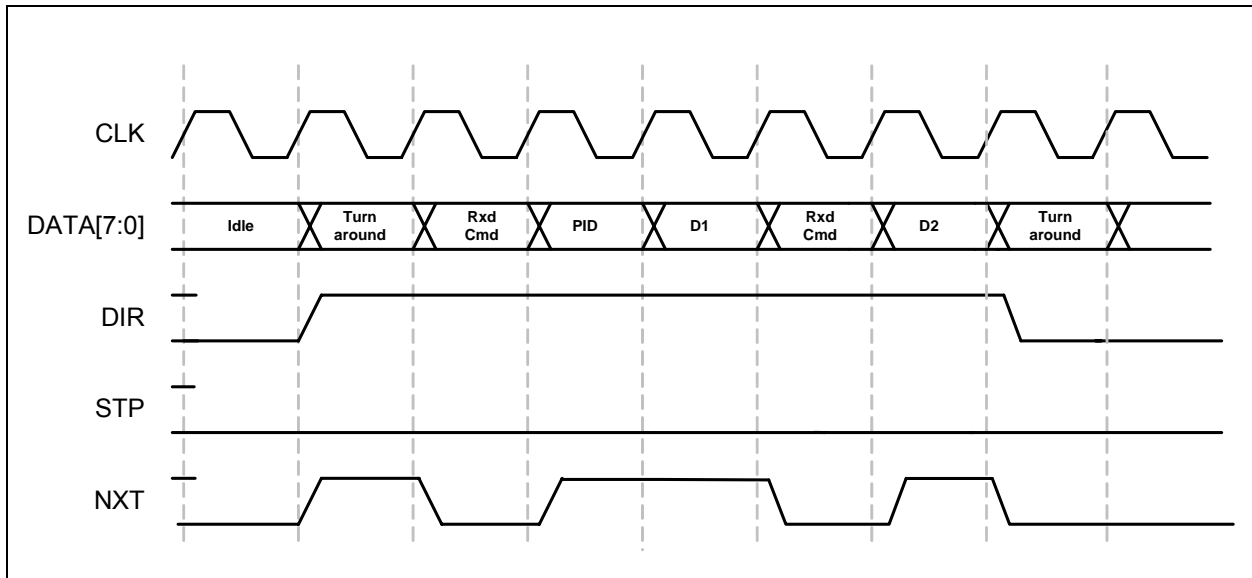
Figure 6.7 ULPI Receive

In [Figure 6.7](#) the PHY asserts DIR to take control of the data bus from the Link. The assertion of DIR and NXT in the same cycle contains additional information that Ractive has been asserted. When NXT is de-asserted and DIR is asserted, the RXD CMD data is transferred to the Link. After the last byte of the USB receive packet is transferred to the PHY, the linestate will return to idle.

The ULPI full speed receiver operates according to the UTMI/ULPI specification. In the full speed case, the NXT signal will assert only when the Data bus has a valid received data byte. When NXT is low with DIR high, the RXD CMD is driven on the data bus.

In full speed, the USB3300 will not issue a Ractive de-assertion in the RXD CMD until the DP/DM linestate transition to idle. This prevents the Link from violating the two full speed bit times minimum turn around time.

6.1.8.1 Disconnect Detection

A High Speed host must detect a disconnect by sampling the transmitter outputs during the long EOP transmitted during a SOF packet. The USB3300 only looks for a high speed disconnect during the long EOP where the period is long enough for the disconnect reflection to return to the host PHY. When a high speed disconnect occurs the USB3300 will return a RXD CMD and set the host disconnect bit in the ULPI interrupt status register (address 13h).

When in FS or LS modes, the Link is expected to handle all disconnect detection.

6.1.9 Low Power Mode

Low Power Mode is a power down state to save current when the USB session is suspended. The Link controls when the PHY is placed into or out of Low Power Mode. In Low Power Mode all of the circuits are powered down except the interface pins, full speed receiver, VBUS comparators, and ID comparator.

6.1.9.1 Entering Low Power/Suspend Mode

To enter Low Power Mode, the Link will write a 0 or clear the *SuspendM* bit in the Function Control Register. Once this write is complete, the PHY will assert DIR high and after five rising edges of CLKOUT, drive the clock low. Once the clock is stopped, the PHY will enter a low power state to conserve current.

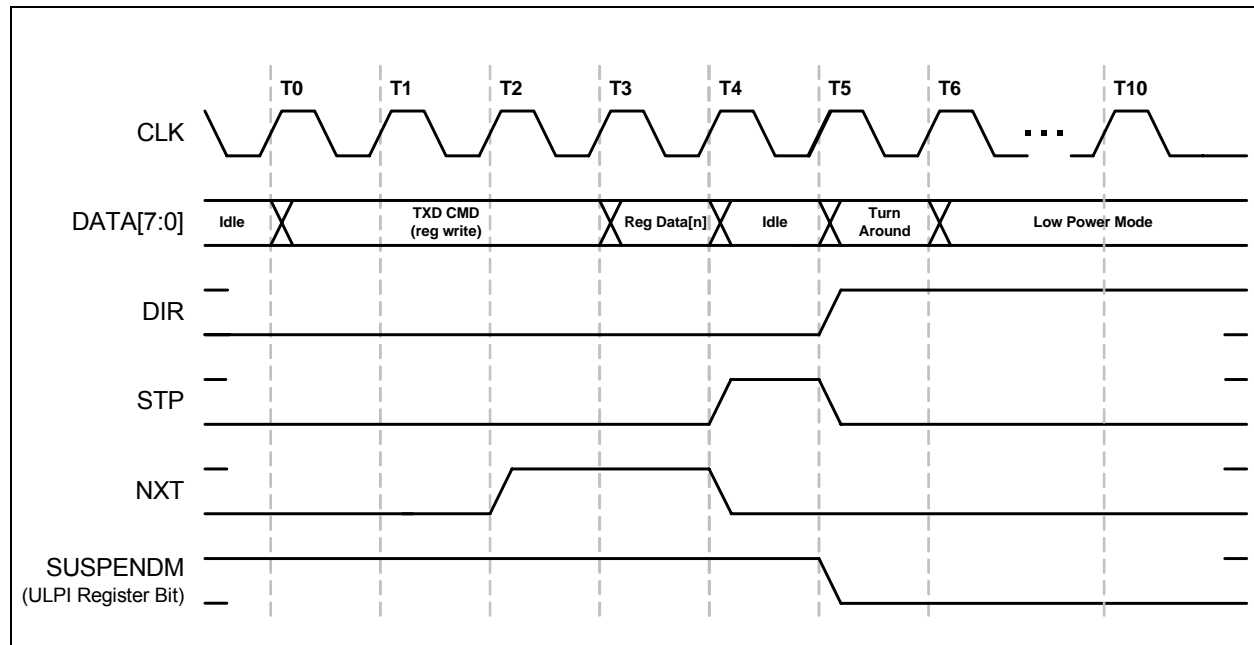

Figure 6.8 Entering Low Power Mode

While in Low Power Mode, the Data interface is redefined so that the Link can monitor Linestate and the Vbus voltage. In Low Power Mode DATA[3:0] are redefined as shown in Table 6.6. Linestate[1:0] is the combinational output of the full speed receivers. The “int” or interrupt signal indicates an unmasked interrupt has occurred. When an unmasked interrupt or linestate change has occurred, the Link is notified and can determine if it should wake-up the PHY.

Table 6.6 Interface Signal Mapping During Low Power Mode

SIGNAL	MAPS TO	DIRECTION	DESCRIPTION
linestate[0]	DATA[0]	OUT	Combinatorial linestate[0] driven directly by FS analog receiver.
linestate[1]	DATA[1]	OUT	Combinatorial linestate[1] driven directly by FS analog receiver.
reserved	DATA[2]	OUT	Driven Low
int	DATA[3]	OUT	Active high interrupt indication. Must be asserted whenever any unmasked interrupt occurs.
reserved	DATA[7:4]	OUT	Driven Low

An unmasked interrupt can be caused by the following comparators changing state, VbusVld, SessVld, SessEnd, and IdGnd. If any of these signals change state during Low Power Mode and either their rising or falling edge interrupt is enabled, DATA[3] will assert. During Low Power Mode, the VbusVld and SessEnd comparators can have their interrupts masked to lower the suspend current. Refer to Section 6.1.9.4.

While in Low Power Mode, the Data bus is driven asynchronously because all of the PHY clocks are stopped during Low Power Mode.

6.1.9.2 Exiting Low Power Mode

To exit Low Power Mode, the Link will assert STP. Upon the assertion of STP, the USB3300 will begin its start-up procedure. After the PHY start-up is complete, the PHY will start the clock on CLKOUT and de-assert DIR. Once DIR has been de-asserted, the Link can de-assert STP when ready and start

operating in Synchronous Mode. The PHY will automatically set the *SuspendM* bit to a 1 in the Function Control register.

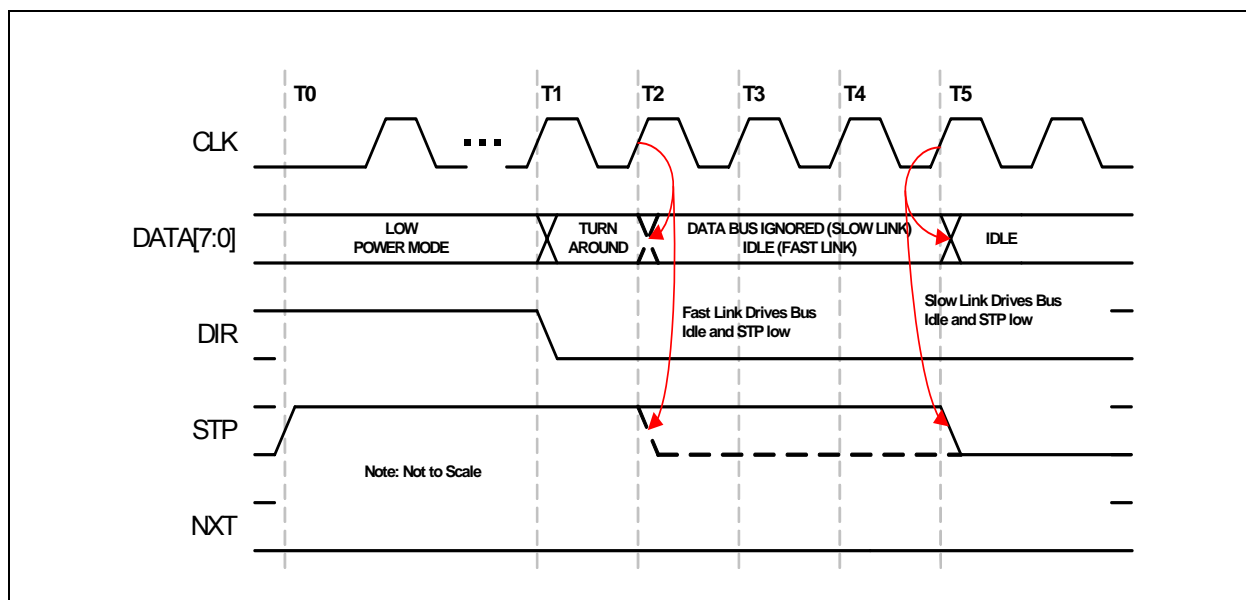

Figure 6.9 Exiting Low Power Mode

The time from T0 to T1 is given in [Table 5.2 on page 15](#).

Should the Link de-assert STP before DIR is de-asserted, the USB3300 will detect this as a false resume request and return to Low Power Mode. This is detailed in section 3.9.4 of the ULPI 1.1 specification.

6.1.9.3 Interface Protection

ULPI protocol assumes that both the Link and PHY will keep the ULPI data bus driven by either the Link when DIR is low or the PHY when DIR is high. The only exception is when DIR has changed state and a turn around cycle occurs for 1 clock period.

In the design of a USB system, there can be cases where the Link may not be driving the ULPI bus to a known state while DIR is low. Two examples where this can happen is because of a slow Link start-up or a hardware reset.

START UP PROTECTION

Upon start-up, when the PHY de-asserts DIR, the Link must be ready to receive commands and drive Idle on the data bus. If the Link is not ready to receive commands or drive Idle, it must assert STP before DIR is de-asserted. The Link can then de-assert STP when it has completed its start-up. If the Link doesn't assert STP before it can receive commands, the PHY may interpret the databus state as a TX CMD and transmit invalid data onto the USB bus, or make invalid register writes.

A Link should be designed to have the default POR state of the STP output high and the data bus tri-stated. The USB3300 has weak pull-downs on the DATA bus to prevent these inputs from floating when not driven.

In some cases, a Link may be software configured and not have control of its STP pin until after the PHY has started. In this case, the USB3300 has an internal pull-up on the STP input pad which will pull STP high while the Link's STP output is tri-stated. The STP pull-up resistor is enabled on POR and can be disabled by setting the *InterfaceProtectDisable* bit 7 of the Interface Control register.

The STP pull-up resistor will pull-up the Link's STP input high until the Link configures and drives STP high. Once the Link completes its start-up, STP can be synchronously driven low.

Datasheet

A Link design which drives STP high during POR can disable the pull-up resistor on STP by setting *InterfaceProtectDisable* bit to 1. A motivation for this is to reduce the suspend current. In Low Power Mode, STP is held low, which would draw current through the pull-up resistor on STP.

WARM RESET

Designers should also consider the case of a warm restart of a Link with a PHY in Low Power Mode. Once the PHY enters Low Power Mode, DIR is asserted and the clock is stopped. The USB3300 looks for STP to be asserted to re-start the clock and then resume normal synchronous operation.

Should the USB3300 be suspended in Low Power Mode, and the Link receives a hardware reset, provision is made to allow the PHY to recover from Low Power Mode and start its clock. If the Link asserts STP on reset, the PHY will exit Low Power Mode and start its clock.

If the Link does not assert STP on reset the interface protection pull-up can be used. When the Link is reset, its STP output will tri-state and the pull-up resistor will pull STP high, signaling the PHY to restart its clock.

6.1.9.4 Minimizing Current in Low Power Mode

In order to minimize the suspend current in Low Power Mode, the OTG comparators can be disabled to reduce suspend current. During suspend, the VbusVId and SessEnd comparators are not needed and can be disabled using the USB Interrupt Enable Rise and USB Interrupt Enable Fall registers. By disabling the interrupt in BOTH the rise and fall registers, the SessEnd and VbusVId comparators are turned off. When exiting suspend, the Link should immediately re-enable the comparators if host or OTG functionality is needed.

In addition to disabling the OTG comparators in suspend, the Link may choose to disable the Interface Protect Circuit. By setting the Interface Control, bit 7, *InterfaceProtectDisable* high, the Link can disable the pull-up resistor on STP.

6.1.10 Full Speed/Low Speed Serial Modes

The USB3300 includes two serial modes to support legacy Links which use either the 3pin or 6pin serial format. To enter either serial mode, the Link will need to write a 1 to the *6-pin FsLsSerialMode* or the *3-pin FsLsSerialMode* bit in the Interface control register. The 6-pin Serial Mode is provided for legacy link designs and is not recommended for new designs.

The serial modes are entered in the same manner as the entry into Low Power Mode. The Link writes the Interface Control register bit for the specific serial mode. The USB3300 will assert DIR and shut off the clock after at least five clock cycles. Then the data bus goes to the format of the serial mode selected.

By default, the PHY will shut off the 60MHz clock to conserve power. Should the Link need the 60Mhz clock to continue during the serial mode of operation, the *ClockSuspendM* bit[3] of the Interface Control Register should be set before entering a serial mode. If set, the 60 Mhz clock will be present during serial modes.

In serial mode, interrupts are possible from unmasked sources. The state of each interrupt source is sampled prior to the assertion of DIR and this is compared against the asynchronous level from interrupt source.

Exiting the serial modes is the same as exiting Low Power Mode. The Link must assert STP to signal the PHY to exit serial mode. Then the PHY can accept a command, DIR is de-asserted and the PHY will wait until the Link de-asserts STP to resume synchronous ULPI operation.

6.1.10.1 3pin FS/LS Serial Mode

Three pin serial mode utilizes the data bus pins for the serial functions shown in [Table 6.7](#).

Table 6.7 Pin Definitions in 3 pin Serial Mode

SIGNAL	CONNECTED TO	DIRECTION	DESCRIPTION
tx_enable	DATA[0]	IN	Active High transmit enable
data	DATA[1]	I/O	Tx differential data on DP/DM when tx_enable is high RX differential data from DP/DM when tx_enable is low
se0	DATA[2]	I/O	Tx SE0 on DP/DM when tx_enable is high RX SE0 from DP/DM when tx_enable is low
interrupt	DATA[3]	OUT	Asserted when any unmasked interrupt occurs. Active high

6.1.11 Reset Pin

The reset input of the USB3300 may be asynchronously asserted and de-asserted so long as it is held in the asserted state continuously for a duration greater than one clkout clock cycle. The reset input may be asserted when the USB3300 clkout signal is not active (i.e. in the suspend state caused by asserting the SuspendM bit) but reset must only be de-asserted when the USB3300 clkout signal is active and the reset has been held asserted for a duration greater than one clkout clock cycle. No other PHY digital input signals may change state for two clkout clock cycles after the de-assertion of the reset signal.

6.2 Hi-Speed USB Transceiver

The SMSC Hi-Speed USB 2.0 Transceiver consists of four blocks in the lower right corner of [Figure 6.1](#). These four blocks are labeled HS XCVR, FS/LS XCVR, Resistors, and Bias Gen.

6.2.1 High Speed and Full Speed Transceivers

The USB3300 transceiver meets all requirements in the USB 2.0 specification.

The receivers connect directly to the USB cable. This block contains a separate differential receiver for HS and FS mode. Depending on the mode, the selected receiver provides the serial data stream through the multiplexer to the RX Logic block. The FS mode section of the FS/HS RX block also consists of a single-ended receiver on each of the data lines to determine the correct FS linestate. For HS mode support, the FS/HS RX block contains a squelch circuit to insure that noise is never interpreted as data.

The transmitters connect directly to the USB cable. The block contains a separate differential FS and HS transmitter which receive encoded, bit stuffed, serialized data from the TX Logic block and transmit it onto the USB cable.

6.2.2 Termination Resistors

The USB3300 transceiver fully integrates all of the USB termination resistors. The USB3300 includes 1.5kΩ pull-up resistors on both DP and DM and a 15kΩ pull-down resistor on both DP and DM. The 45Ω high speed termination resistors are also integrated. These resistors require no tuning or trimming by the Link. The state of the resistors is determined by the operating mode of the PHY. The possible valid resistor combinations are shown in [Table 6.8](#). Operation is guaranteed in the configurations given in the table below.

Datasheet

- RPU_DP_EN activates the 1.5kΩ DP pull-up resistor
- RPU_DM_EN activates the 1.5kΩ DM pull-up resistor
- RPD_DP_EN activates the 15kΩ DP pull-down resistor
- RPD_DM_EN activates the 15kΩ DM pull-down resistor
- HSTERM_EN activates the 45Ω DP and DM high speed termination resistors

Table 6.8 DP/DM termination vs. Signaling Mode

SIGNALING MODE	REGISTER SETTINGS					RESISTOR SETTINGS				
	XCVRSELECT[1:0]	TERMSELECT	OPMODE[1:0]	DPPULLDOWN	DMPULLDOWN	RPU_DP_EN	RPU_DM_EN	RPD_DP_EN	RPD_DM_EN	HSTERM_EN
General Settings										
Tri-State Drivers	XXb	Xb	01b	Xb	Xb	0b	0b	0b	0b	0b
Power-up or $V_{bus} < V_{SESEND}$	01b	0b	00b	1b	1b	0b	0b	1b	1b	0b
Host Settings										
Host Chirp	00b	0b	10b	1b	1b	0b	0b	1b	1b	1b
Host Hi-Speed	00b	0b	00b	1b	1b	0b	0b	1b	1b	1b
Host Full Speed	X1b	1b	00b	1b	1b	0b	0b	1b	1b	0b
Host HS/FS Suspend	01b	1b	00b	1b	1b	0b	0b	1b	1b	0b
Host HS/FS Resume	01b	1b	10b	1b	1b	0b	0b	1b	1b	0b
Host low Speed	10b	1b	00b	1b	1b	0b	0b	1b	1b	0b
Host LS Suspend	10b	1b	00b	1b	1b	0b	0b	1b	1b	0b
Host LS Resume	10b	1b	10b	1b	1b	0b	0b	1b	1b	0b
Host Test J/Test_K	00b	0b	10b	1b	1b	0b	0b	1b	1b	1b
Peripheral Settings										
Peripheral Chirp	00b	1b	10b	0b	0b	1b	0b	0b	0b	0b
Peripheral HS	00b	0b	00b	0b	0b	0b	0b	0b	0b	1b
Peripheral FS	01b	1b	00b	0b	0b	1b	0b	0b	0b	0b
Peripheral HS/FS Suspend	01b	1b	00b	0b	0b	1b	0b	0b	0b	0b
Peripheral HS/FS Resume	01b	1b	10b	0b	0b	1b	0b	0b	0b	0b
Peripheral LS	10b	1b	00b	0b	0b	0b	1b	0b	0b	0b
Peripheral LS Suspend	10b	1b	00b	0b	0b	0b	1b	0b	0b	0b
Peripheral LS Resume	10b	1b	10b	0b	0b	0b	1b	0b	0b	0b
Peripheral Test J/Test K	00b	0b	10b	0b	0b	0b	0b	0b	0b	1b

Table 6.8 DP/DM termination vs. Signaling Mode (continued)

SIGNALING MODE	REGISTER SETTINGS					RESISTOR SETTINGS				
	XCVRSELECT[1:0]	TERMSELECT	OPMODE[1:0]	DPPULLDOWN	DMPULLDOWN	RPU_DP_EN	RPU_DM_EN	RPD_DP_EN	RPD_DM_EN	HSTERM_EN
OTG device, Peripheral Chirp	00b	1b	10b	0b	1b	1b	0b	0b	1b	0b
OTG device, Peripheral HS	00b	0b	00b	0b	1b	0b	0b	0b	1b	1b
OTG device, Peripheral FS	01b	1b	00b	0b	1b	1b	0b	0b	1b	0b
OTG device, Peripheral HS/FS Suspend	01b	1b	00b	0b	1b	1b	0b	0b	1b	0b
OTG device, Peripheral HS/FS Resume	01b	1b	10b	0b	1b	1b	0b	0b	1b	0b
OTG device, Peripheral Test J/Test K	00b	0b	10b	0b	1b	0b	0b	0b	1b	1b

Note: This is the same as Table 40, Section 4.4 of the ULPI 1.1 specification.

6.2.3 Bias Generator

This block consists of an internal bandgap reference circuit used for generating the driver current and the biasing of the analog circuits. This block requires an external 12KΩ, 1% tolerance, external reference resistor connected from RBIAS to ground.

6.3 Crystal Oscillator and PLL

The USB3300 uses an internal crystal driver and PLL sub-system to provide a clean 480MHz reference clock that is used by the PHY during both transmit and receive. The USB3300 requires a clean 24MHz crystal or clock as a frequency reference. If the 24MHz reference is noisy or off frequency the PHY may not operate correctly.

The USB3300 can use either a crystal or an external clock oscillator for the 24MHz reference. The crystal is connected to the XI and XO pins as shown in the application diagram, [Figure 7.1](#). If a clock oscillator is used the clock should be connected to the XI input and the XO pin left floating. When an external clock is used the XI pin is designed to be driven with a 0 to 3.3 volt signal. When using an external clock the user needs to take care to ensure the external clock source is clean enough to not corrupt the high speed eye performance.

Once the 480MHz PLL has locked to the correct frequency it will drive the CLKOUT pin with a 60MHz clock. The USB3300 is guaranteed to start the clock within the time specified in [Table 5.2](#). The USB3300 does not support using an external 60MHz clock input.

For Host Applications the USB3300 implements the ULPI *AutoResume* bit in the Interface Control register. The default *AutoResume* state is 0 and this bit should be enabled for Host applications. For more details please see sections 7.1.77 and 7.9 of the USB specification.

6.4 Internal Regulators and POR

The USB3300 includes an integrated set of built in power management functions, including a POR generator. Internal regulators enable the USB3300 to be powered from a single 3.3 volt power supply, thereby reducing the bill of materials and simplifying product design.

Datasheet

6.4.1 Internal Regulators

The USB3300 has two internal regulators that create two 1.8V outputs (labeled VDD1.8 and VDDA1.8) from the 3.3volt power supply input (VDD3.3). Each regulator requires an external 4.7uF +/-20% low ESR bypass capacitor to ensure stability. X5R or X7R ceramic capacitors are recommended since they exhibit an ESR lower than 0.1ohm at frequencies greater than 10kHz.

Note: The specific capacitor recommendations for each pin are detailed in [Table 3.1](#), and shown in [Figure 7.1 on page 46](#). The USB3300 regulators are designed to generate a 1.8 volt supply for the USB3300 only. Using the regulators to provide current for other circuits is not recommended and SMSC does not guarantee USB performance or regulator stability.

6.4.2 Power On Reset (POR)

The USB3300 provides an internal POR circuit that generates a reset pulse once the PHY supplies are stable. This reset will set all of the ULPI registers to their default values and start the PHY in normal operation. Cycling the 3.3 volt power supply is the only method for the PHY to reset the ULPI registers to their default states. The Link can write the registers to their default states at any time in normal operation.

The RESET pin has the same functionality as the RESET register in the Function Control Register.

6.5 USB On-The-Go (OTG) Module

The USB3300 provides support for USB OTG. OTG allows the USB3300 to be dynamically configured as a host or a device depending on the type of cable inserted into the Mini-AB connector. When the Mini-A plug of a cable is inserted into the Mini-AB connector, the USB device becomes the A-device. When a Mini-B plug is inserted, the device becomes the B-device. The OTG A-device behaves similar to a Host while the B-device behaves similar to a peripheral. The differences are covered in the OTG supplement.

The OTG Module meets all the requirements in the "On-The-Go Supplement to the USB 2.0 Specification". In applications where only Host or Device is required, the OTG Module is unused.

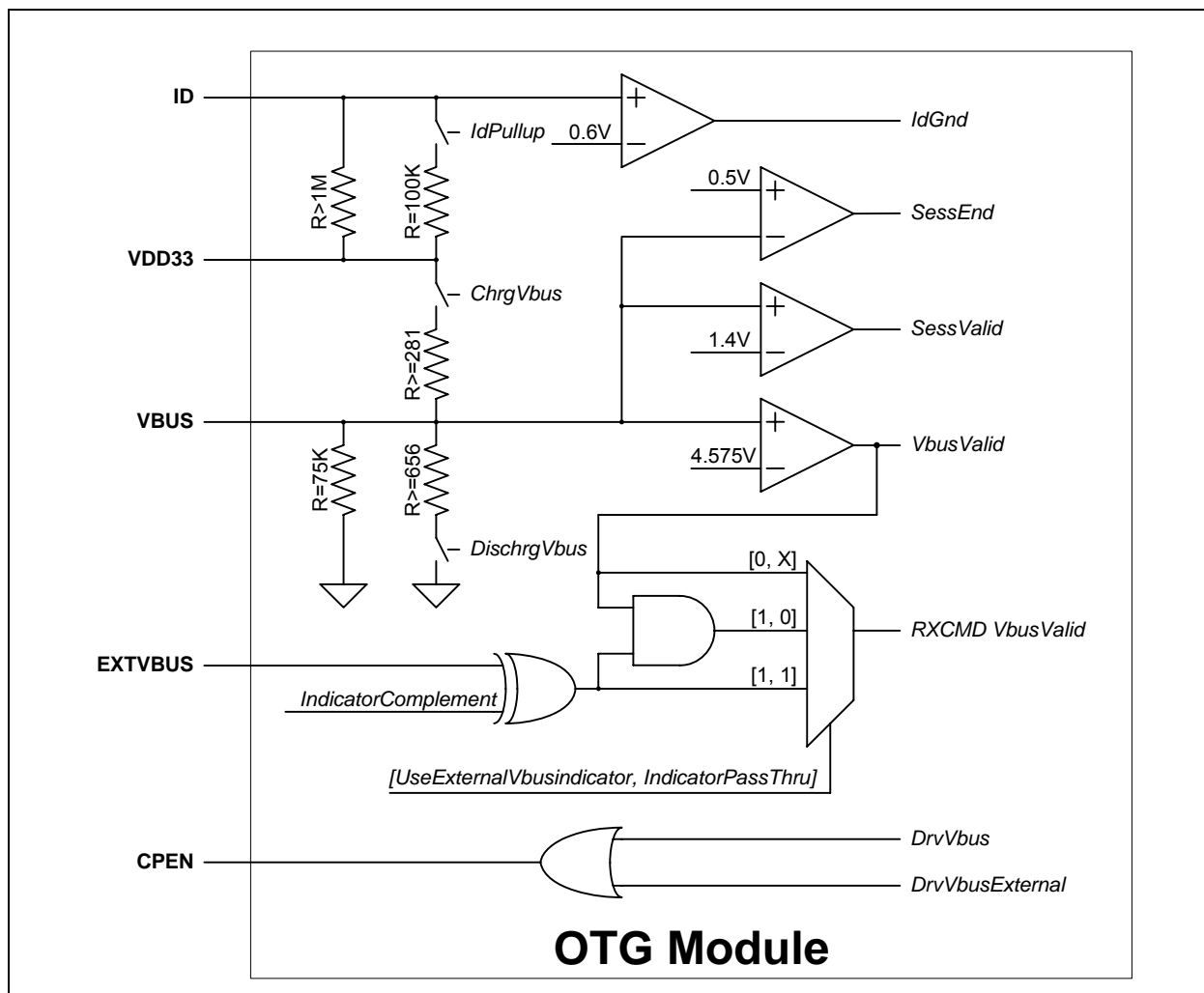
Figure 6.10 USB3300 On-the-Go Module

The OTG Module can be broken into 4 main blocks; ID Detection, VBUS Control, Driving External Vbus, and External Vbus Detection. Each of these blocks is covered in the sections below.

6.5.1 ID Detection

The USB3300 provides an ID pin to determine the type of USB cable connected. When the Mini-A Plug of a USB cable is inserted into the Mini-AB connector, the ID pin is shorted to ground. When the Mini-B Plug is inserted into the Mini-AB connector, the ID pin is allowed to float.

Table 6.9 IdGnd vs. USB Cable Type

USB PLUG	OTG ROLE	ID VOLTAGE	IDGND
A	HOST	0	0
B	PERIPHERAL	3.3	1

The USB3300 provides an integrated pull-up resistor and a comparator to detect if the ID pin is floating or grounded. An integrated pull-up resistor is provided to pull the ID pin high to VDD3.3 when a Mini-B plug is inserted and the cable is floating. When a Mini-A plug is connected, the pull-up resistor will

Datasheet

be overpowered and the ID pin will be brought to ground. To save current when a Mini-A Plug is inserted, the ID pull-up resistor can be disabled by clearing the *IdPullUp* bit in the OTG Control register. To prevent the ID pin from floating to a random value, a weak pull-up resistor is provided at all times. The circuits related to the ID comparator are shown in [Figure 6.10](#) and their related parameters are shown in [Table 5.6](#).

The status of *IdGnd* can be read by reading the ULPI USB Interrupt Status register, bit 4. It can also be set to generate an interrupt, in host mode, when *IdGnd* changes with the ULPI Interrupt Enable registers.

6.5.2 VBUS Control

The USB3300 includes all of the Vbus comparators required for OTG. The *VbusVld*, *SessVld*, and *SessEnd* comparators are fully integrated into the USB3300. These comparators are used to ensure the Vbus voltage is the correct value for proper USB operation.

The *VbusVld* comparator is used by the Link, when configured as an A device, to ensure that the Vbus voltage on the cable is valid. The *SessVld* comparator is used by the Link when configured as both an A or B device to indicate a session is requested or valid. Finally the *SessEnd* comparator is used by the B-device to indicate a USB session has ended.

Also included in the VBUS Control block are the resistors used for Vbus pulsing in SRP. The resistors used for VBUS pulsing include a pull-down to ground and a pull-up to VDD3.3.

6.5.2.1 SessEnd Comparator

The *SessEnd* comparator is designed to trip when Vbus is less than 0.5 volts. When Vbus goes below 0.5 volts the session is considered to be ended and *SessEnd* will transition from 0 to 1. The *SessEnd* comparator can be disabled by clearing this bit in both the rising and falling interrupt enable registers. When disabled the *SessEnd* bit in the interrupt status register will read 0. The *SessEnd* comparator trip points are detailed in [Table 5.6](#).

6.5.2.2 SessVld Comparator

The *SessVld* comparator is used when the PHY is configured as both an A and B device. When configured as an A device, the *SessVld* is used to detect Session Request protocol (SRP). When configured as a B device, *SessVld* is used to detect the presence of Vbus. The *SessVld* interrupts can be disabled by clearing this bit in both the rising and falling interrupt enable registers. When the interrupts are disabled, the *SessVld* comparator is not disabled and its state can be read in the interrupt status register. The *SessVld* comparator trip point is detailed in [Table 5.6](#).

Note: The OTG Supplement specifies a voltage range for A-Device Session Valid and B-Device Session Valid comparator. The USB3300 PHY combines the two comparators into one and uses the narrower threshold range.

6.5.2.3 VbusVld Comparator

The final Vbus comparator is the *VbusVld* comparator. This comparator is only used when configured as an A-device. In the OTG protocol the A-device is responsible to ensure that the Vbus voltage is within a certain range. The *VbusVld* comparator can be disabled by clearing both the rising and falling edge interrupts. When disabled a read of bit 1, in the Interrupt Status Register will return a 0. The *VbusVld* comparator trip points are detailed in [Table 5.6](#).

When the A-device is able to provide 8-100mA it must ensure Vbus doesn't go below 4.4 volts. If the A-device can provide 100-500mA on Vbus it must ensure that Vbus does not go below 4.75 volts.

The internal Vbus comparator is designed to ensure that Vbus remains above 4.4 volts. If the design is required to supply over 100mA the USB3300 provides an input for a more accurate Vbus comparator or fault (over current) detection described in [Section 6.5.4](#).

6.5.2.4 Vbus Pull-up and Pull-down Resistors

In addition to the internal Vbus comparators the USB3300 also includes the integrated Vbus pull-up and pull-down resistors used for Vbus Pulsing. To discharge the Vbus voltage, so that a Session Request can begin, the USB3300 provides a pull-down resistor from Vbus to Ground. This resistor is controlled by the *DischargeVbus* bit 3 of the OTG Control register, defined in the ULPI specifications. The pull-up resistor is connected between Vbus and VDD3.3. This resistor is used to pull Vbus above 2.1 volts so that the A-Device knows that a USB session has been requested. The state of the pull-up resistor is controlled by the bit 4 *ChargeVbus* of the OTG Control register, defined in the ULPI specifications. The Pull-Up and Pull-Down resistor values are detailed in [Table 5.6](#).

6.5.2.5 Vbus Input Impedance

The OTG Supplement requires an A-Device that supports Session request protocol to have an input impedance less than 100kohm and greater the 40kohm to ground. In addition, if configured as a B-Device, the PHY cannot draw more then 150uA from Vbus. The USB3300 provides a 75kΩ nominal resistance to ground which meets the above requirements, see [Table 5.6](#).

6.5.3 Driving External Vbus

When a system is operating as a host, it is required to source 5 volts on VBUS. The USB3300 fully supports VBUS power control using external devices. The USB3300 provides an active high control signal, CPEN, which is dedicated to controlling the Vbus supply when configured as an A-Device. The USB3300 also supports external Vbus fault detection detailed in [Section 6.5.4](#).

CPEN is asserted when the ULPI OTG Control register bit 5 *DrvVbus* or bit 6, *DrvVbusExternal* is set high. To be compatible with Link designs that support both internal and external Vbus supplies the *DrvVbus* and *DrvVbusExternal* bits in the OTG Control Register are or'd together. This enables the Link to set either bit to access the external Vbus enable (CPEN.) This logic is shown in [Figure 6.10](#). *DrvVbus* and *DrvVbusExternal* are set to 0 on POR.

6.5.4 External Vbus Indicator

The USB3300 has fully implemented the External Vbus detection described in the ULPI 1.1 specification. The block diagram of the External Vbus detection is shown in [Figure 6.10](#) and in [Table 6.10](#).

Table 6.10 External Vbus Indicator Logic

TYPICAL APPLICATION	USE EXTERNAL VBUS INDICATOR	INDICATOR PASS THRU	INDICATOR COMPLEMENT	RXCMD VBUS VALID ENCODING SOURCE
OTG Device	0	X	X	Internal VbusVld comparator (Default)
	1	1	0	External active high VbusVld signal
	1	1	1	External active low VbusVld signal
	1	0	0	External active high power fault signal qualified with internal VbusVld comparator. (Note 6.1)
	1	0	1	External active low power fault signal qualified with internal VbusVld comparator. (Note 6.1)

Table 6.10 External Vbus Indicator Logic (continued)

TYPICAL APPLICATION	USE EXTERNAL VBUS INDICATOR	INDICATOR PASS THRU	INDICATOR COMPLEMENT	RXCMD VBUS VALID ENCODING SOURCE
Standard Host	1	1	0	External active high power fault signal
	1	1	1	External active low power fault signal
Standard Peripheral	0	X	X	Internal VbusVld comparator. This should not be used by the Link. (Note 6.2)

Note 6.1 SMSC does not recommend using the ExternalVbus signal qualified with the internal VbusVld comparator.

Note 6.2 A peripheral should not use VbusVld to begin operation. The peripheral should use SessVld because the internal VbusVld threshold can be above the Vbus voltage required for USB peripheral operation.

A host PHY may use an active high or low fault by setting the *IndicatorComplement* bit [5] in the Interface Control register. Also this implementation supports the *IndicatorPassThru* bit [6] in the Interface Control register, which allows a choice of having the External Vbus input qualified (and'ed) with the external vbus comparator output. To use the External Vbus Input the *UseExternalVbusIndicator* bit [7] must be set in the OTG control register. The default is not to use this input.

The EXTVBUS pin has a built in pull down resistor that is controlled by the *UseExternalVbusIndicator* bit [7] of the OTG control register. When *UseExternalVbusIndicator* is set to 0 (default) the pull down resistor is activated to prevent the pin from floating when it is unused. When *UseExternalVbusIndicator* is set to 1 the pull down resistor is disconnected.

Chapter 7 Application Notes

7.1 Application Diagram

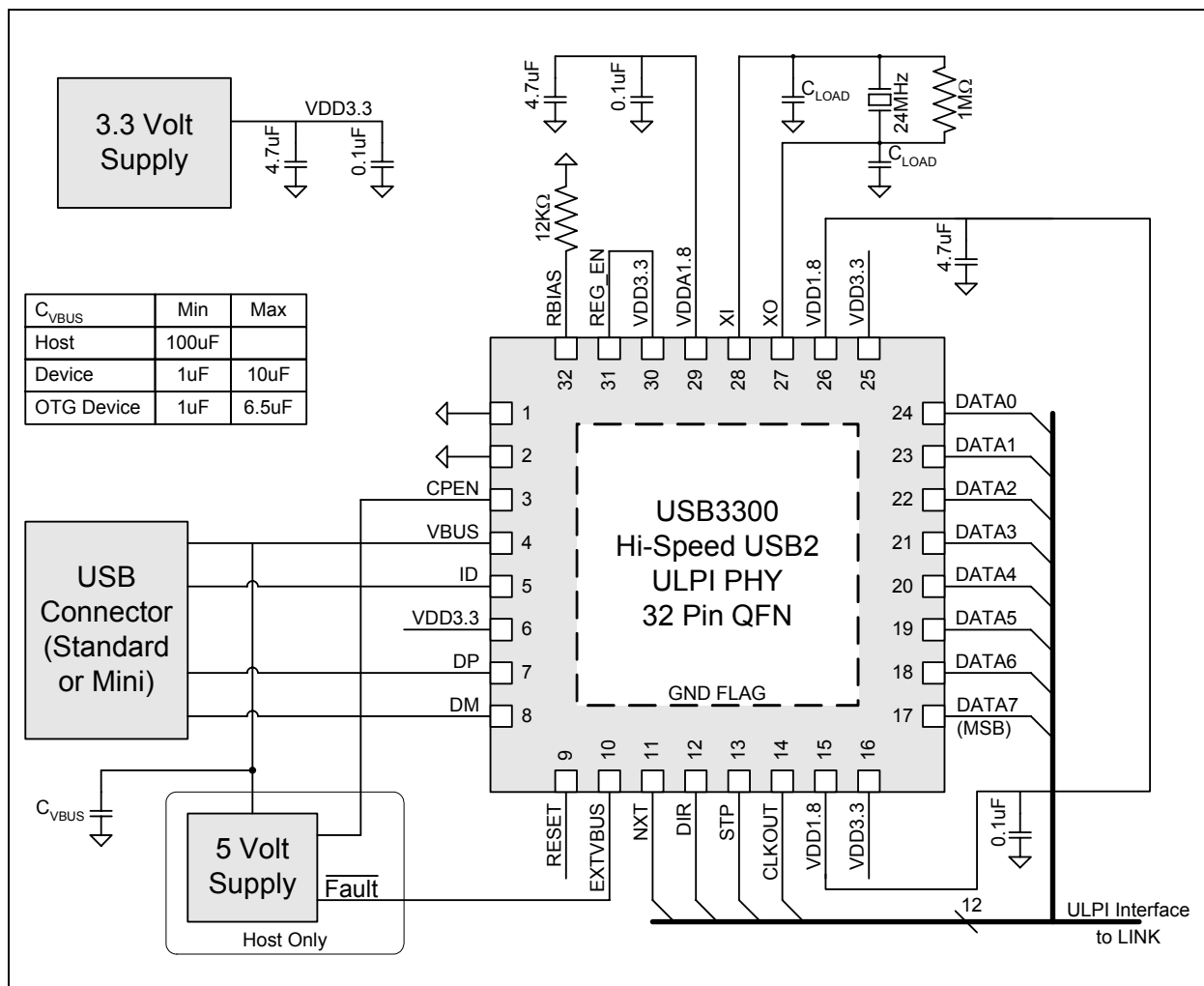

Figure 7.1 USB3300 Application Diagram

In addition to the 4.7uF bypass capacitor for VDD3.3 shown in Figure 7.1, each VDD3.3 pin should have an additional capacitor to ground, of value 0.01 or 0.1 uF (not shown for clarity). Approximately equal numbers of each value should be used.

7.2 Multi-port Applications

To support multiple ports a single USB3300 host can be combined with one of SMSC's many hub products to expand the number of ports. SMSC has 2-port, 3-port, 4-port, and 7-port hub designs which can be used to expand the number of ports in a design.

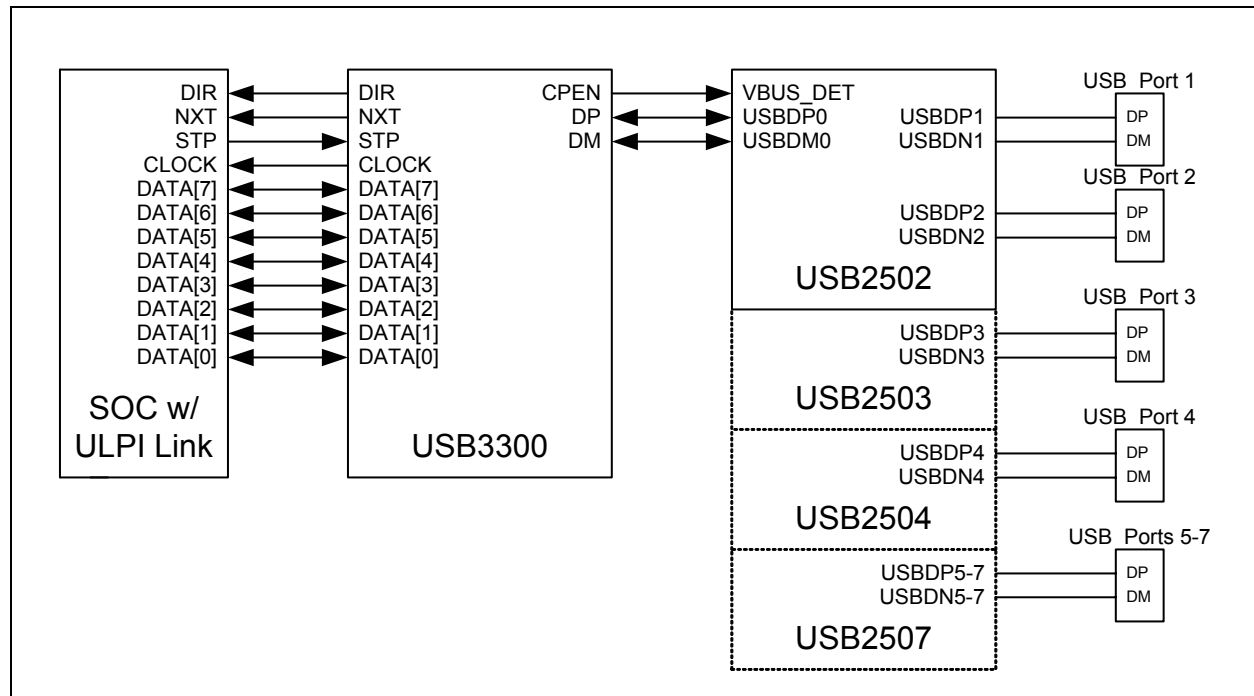

Figure 7.2 Expanding Downstream Ports for USB3300 Host Applications

Using a SMSC hub to expand the number of ports allows a single Link to run several USB devices without a separate Link to support each USB port. Another advantage of using a SMSC hub is on products where the main board is not located near the USB ports. The USB3300 can be placed on the main board with the Link ASIC and the hub can be placed on a separate board next to the USB ports. The only data connection required between the boards is DP and DM.

The CPEN output of the USB3300 is optional and can be used to turn the Hub on or off to lower current when the USB connection isn't needed.

7.3 Evaluation Board

An evaluation board, EVB-USB3300, is available for building a prototype system with the USB3300. The evaluation board provides an industry standard T&MT connector to interface a ULPI Link controller and a Mini-AB connector for the USB cable. A 500mA fault protected 5V Vbus switch that is controlled by the USB3300 is also included.

7.4 ESD Performance

The USB3300 is protected from ESD strikes. By eliminating the requirement for external ESD protection devices, board space is conserved, and the board manufacturer is enabled to reduce cost. The advanced ESD structures integrated into the USB3300 protect the device whether or not it is powered up.

7.4.1 Human Body Model (HBM) Performance

HBM testing verifies the ability to withstand the ESD strikes like those that occur during handling and manufacturing, and is done without power applied to the IC. To pass the test, the device must have no change in operation or performance due to the event. All pins on the USB3300 provide $\pm 8\text{kV}$ HBM protection.

7.4.2 IEC61000-4-2 Performance

The IEC61000-4-2 ESD specification is an international standard that addresses system-level immunity to ESD strikes while the end equipment is operational. In contrast, the HBM ESD tests are performed at the device level with the device powered down.

SMSC contracts with independent laboratories to test the USB3300 to IEC61000-4-2 in a working system. Reports are available upon request. Please contact your SMSC representative, and request information on 3rd party ESD test results. The reports show that systems designed with the USB3300 can safely dissipate $\pm 15\text{kV}$ air discharges and $\pm 8\text{kV}$ contact discharges per the IEC61000-4-2 specification without additional board level protection.

Both air discharge and contact discharge test techniques for applying stress conditions are defined by the IEC61000-4-2 ESD document.

7.4.2.1 AIR DISCHARGE

To perform this test, a charged electrode is moved close to the system being tested until a spark is generated. This test is difficult to reproduce because the discharge is influenced by such factors as humidity, the speed of approach of the electrode, and construction of the test equipment.

7.4.2.2 CONTACT DISCHARGE

The uncharged electrode first contacts the pin to prepare this test, and then the probe tip is energized. This yields more repeatable results, and is the preferred test method. The independent test laboratories contracted by SMSC provide test results for both types of discharge methods.

Chapter 8 Package Outline

The USB3300 is offered in a compact 32 pin lead-free QFN package.

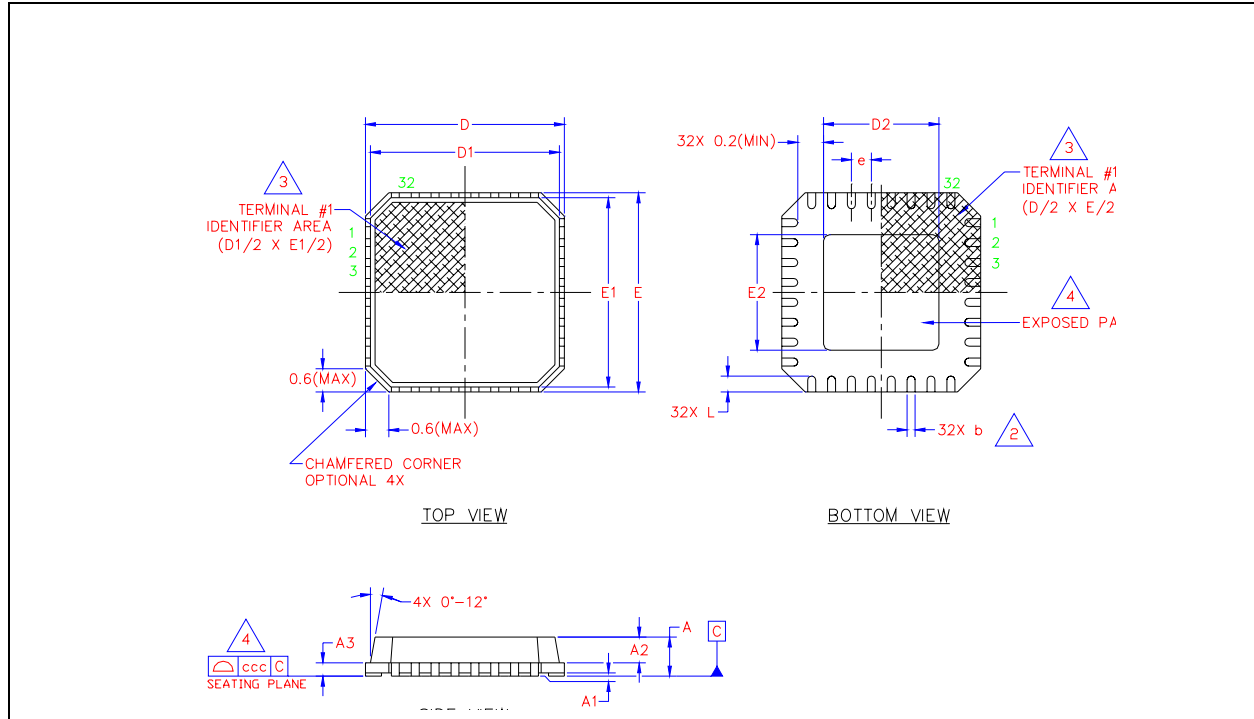

Figure 8.1 USB3300-EZK 32 Pin QFN Package Outline, 5 x 5 x 0.9 mm Body (Lead-Free)

Table 8.1 32 Terminal QFN Package Parameters

	MIN	NOMINAL	MAX	REMARKS
A	0.70	~	1.00	Overall Package Height
A1	0	0.02	0.05	Standoff
A2	~	~	0.90	Mold Thickness
A3	0.20 REF			Copper Lead-frame Substrate
D	4.85	5.0	5.15	X Overall Size
D1	4.55	~	4.95	X Mold Cap Size
D2	3.15	3.3	3.45	X exposed Pad Size
E	4.85	5.0	5.15	Y Overall Size
E1	4.55	~	4.95	Y Mold Cap Size
E2	3.15	3.3	3.45	Y exposed Pad Size
L	0.30	~	0.50	Terminal Length
e	0.50 BSC			Terminal Pitch
b	0.18	0.25	0.30	Terminal Width
ccc	~	~	0.08	Coplanarity

Notes:

1. Controlling Unit: millimeter.
2. Dimension b applies to plated terminals and is measured between 0.15mm and 0.30mm from the terminal tip. Tolerance on the true position of the leads is ± 0.05 mm at maximum material conditions (MMC).
3. Details of terminal #1 identifier are optional but must be located within the zone indicated.
4. Coplanarity zone applies to exposed pad and terminals.