

## Single P-Channel 20-V (D-S) MOSFET With Schottky Diode

<b>MOSFET PRODUCT SUMMARY</b>		
$V_{DS}$ (V)	$r_{DS(on)}$ ( $\Omega$ )	$I_D$ (A)
-20	0.048 @ $V_{GS} = -4.5$ V	-6.3
	0.068 @ $V_{GS} = -2.5$ V	-5.3
	0.090 @ $V_{GS} = -1.8$ V	-4.6

<b>SCHOTTKY PRODUCT SUMMARY</b>		
$V_{KA}$ (V)	$V_f$ (V) Diode Forward Voltage	$I_F$ (A)
20	0.48 V @ 0.5 A	1.0

**FEATURES**

- TrenchFET® Power MOSFETS: 1.8-V Rated
- Ultra-Low Thermal Resistance, PowerPAK® Package with Low 1.07-mm Profile

**APPLICATIONS**

- Charger Switching

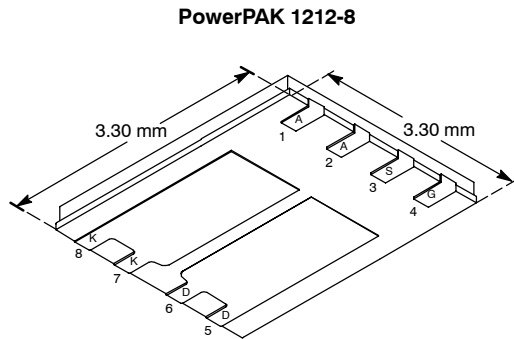

Bottom View

Ordering Information: Si7705DN-T1

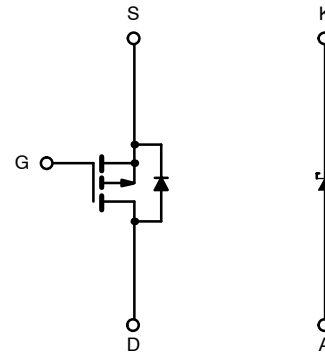

P-Channel MOSFET

<b>ABSOLUTE MAXIMUM RATINGS (<math>T_A = 25^\circ\text{C}</math> UNLESS OTHERWISE NOTED)</b>				
Parameter	Symbol	10 sec	Steady State	Unit
Drain-Source Voltage (MOSFET and Schottky)	$V_{DS}$	-20		V
Reverse Voltage (Schottky)	$V_{KA}$	20		
Gate-Source Voltage (MOSFET)	$V_{GS}$	$\pm 8$		
Continuous Drain Current ( $T_J = 150^\circ\text{C}$ ) (MOSFET) <sup>a</sup>	$T_A = 25^\circ\text{C}$	-6.3	-4.3	A
	$T_A = 85^\circ\text{C}$	-4.5	-3.1	
Pulsed Drain Current (MOSFET)	$I_{DM}$	-20		
Continuous Source Current (MOSFET Diode Conduction) <sup>a</sup>	$I_S$	-2.3	-1.1	
Average Forward Current (Schottky)	$I_F$	1.0		
Pulsed Forward Current (Schottky)	$I_{FM}$	7		
Maximum Power Dissipation (MOSFET) <sup>a</sup>	$T_A = 25^\circ\text{C}$	2.8	1.3	W
	$T_A = 85^\circ\text{C}$	1.5	0.7	
Maximum Power Dissipation (Schottky) <sup>a</sup>	$T_A = 25^\circ\text{C}$	2.0	1.1	
	$T_A = 85^\circ\text{C}$	1.0	0.6	
Operating Junction and Storage Temperature Range	$T_J, T_{stg}$	-55 to 150		$^\circ\text{C}$

Notes

a. Surface Mounted on 1" x 1" FR4 Board.

THERMAL RESISTANCE RATINGS						
Parameter		Device	Symbol	Typical	Maximum	Unit
Junction-to-Ambient <sup>a</sup>	t ≤ 10 sec	MOSFET	R <sub>thJA</sub>	35	44	°C/W
		Schottky		51	64	
	Steady State	MOSFET		75	94	
		Schottky		91	115	
Junction-to-Case (Drain)	Steady State	MOSFET	R <sub>thJC</sub>	4	5	
		Schottky		10	12	

## Notes

a. Surface Mounted on 1" x 1" FR4 Board.

MOSFET SPECIFICATIONS (T <sub>J</sub> = 25°C UNLESS OTHERWISE NOTED)						
Parameter	Symbol	Test Condition	Min	Typ	Max	Unit
<b>Static</b>						
Gate Threshold Voltage	V <sub>GS(th)</sub>	V <sub>DS</sub> = V <sub>GS</sub> , I <sub>D</sub> = -250 μA	-0.45			V
Gate-Body Leakage	I <sub>GSS</sub>	V <sub>DS</sub> = 0 V, V <sub>GS</sub> = ±8 V			±100	nA
Zero Gate Voltage Drain Current	I <sub>DSS</sub>	V <sub>DS</sub> = -16 V, V <sub>GS</sub> = 0 V			-1	μA
		V <sub>DS</sub> = -16 V, V <sub>GS</sub> = 0 V, T <sub>J</sub> = 85°C			-5	
On-State Drain Current <sup>a</sup>	I <sub>D(on)</sub>	V <sub>DS</sub> ≤ -5 V, V <sub>GS</sub> = -4.5 V	-20			A
Drain-Source On-State Resistance <sup>a</sup>	r <sub>DS(on)</sub>	V <sub>GS</sub> = -4.5 V, I <sub>D</sub> = -6.3 A		0.040	0.048	Ω
		V <sub>GS</sub> = -2.5 V, I <sub>D</sub> = -5.3 A		0.054	0.068	
		V <sub>GS</sub> = -1.8 V, I <sub>D</sub> = -1 A		0.070	0.090	
Forward Transconductance <sup>a</sup>	g <sub>fs</sub>	V <sub>DS</sub> = -10 V, I <sub>D</sub> = -6.3 A		14		S
Diode Forward Voltage <sup>a</sup>	V <sub>SD</sub>	I <sub>S</sub> = -2.3 A, V <sub>GS</sub> = 0 V		-0.8	-1.2	V
<b>Dynamic<sup>b</sup></b>						
Total Gate Charge	Q <sub>g</sub>	V <sub>DS</sub> = -10 V, V <sub>GS</sub> = -4.5 V, I <sub>D</sub> = -6.3 A		11	17	nC
Gate-Source Charge	Q <sub>gs</sub>			2.7		
Gate-Drain Charge	Q <sub>gd</sub>			1.9		
Turn-On Delay Time	t <sub>d(on)</sub>	V <sub>DD</sub> = -10 V, R <sub>L</sub> = 10 Ω I <sub>D</sub> ≅ -1 A, V <sub>GEN</sub> = -4.5 V, R <sub>G</sub> = 6 Ω		70	105	ns
Rise Time	t <sub>r</sub>			75	110	
Turn-Off Delay Time	t <sub>d(off)</sub>			20	30	
Fall Time	t <sub>f</sub>			45	70	

## Notes

a. Pulse test; pulse width ≤ 300 μs, duty cycle ≤ 2%.

b. Guaranteed by design, not subject to production testing.

SCHOTTKY SPECIFICATIONS (T <sub>J</sub> = 25°C UNLESS OTHERWISE NOTED)						
Parameter	Symbol	Test Condition	Min	Typ	Max	Unit
Forward Voltage Drop	V <sub>F</sub>	I <sub>F</sub> = 0.5 A		0.42	0.48	V
		I <sub>F</sub> = 0.5 A, T <sub>J</sub> = 125°C		0.33	0.4	
Maximum Reverse Leakage Current	I <sub>rm</sub>	V <sub>r</sub> = 20 V		0.002	0.100	mA
		V <sub>r</sub> = 20 V, T <sub>J</sub> = 85°C		0.10	1	
		V <sub>r</sub> = 20 V, T <sub>J</sub> = 125°C		1.5	10	
Junction Capacitance	C <sub>T</sub>	V <sub>r</sub> = 10 V		31		pF



**TYPICAL CHARACTERISTICS (25°C UNLESS NOTED) MOSFET**

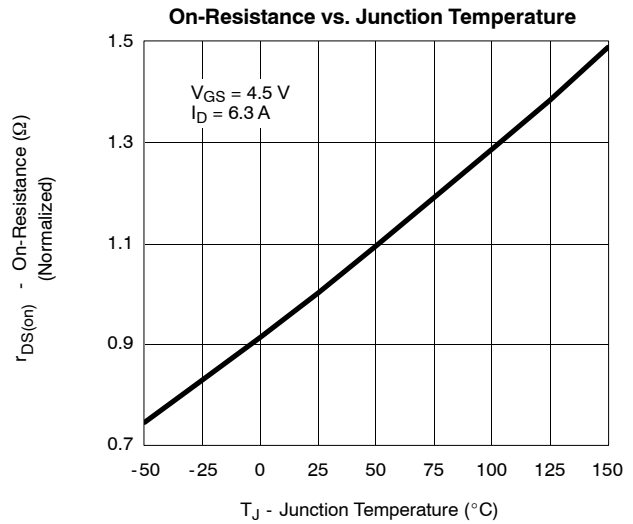
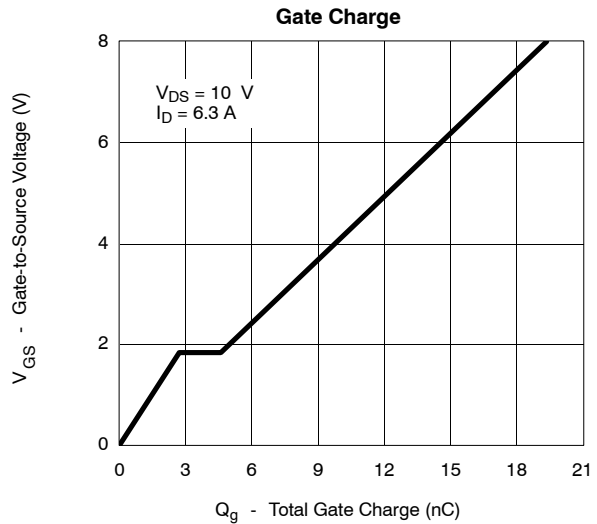
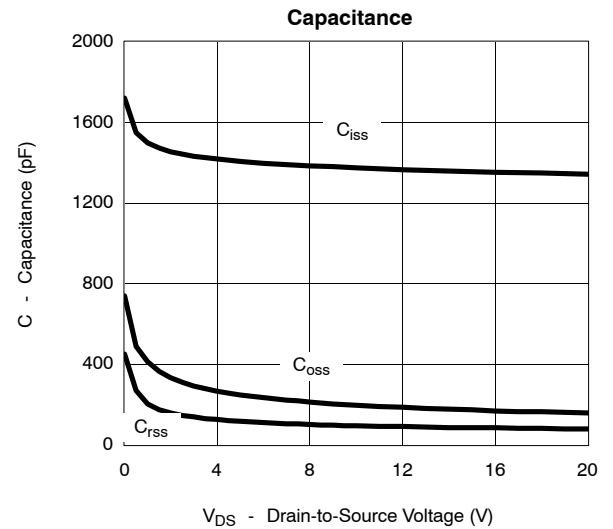
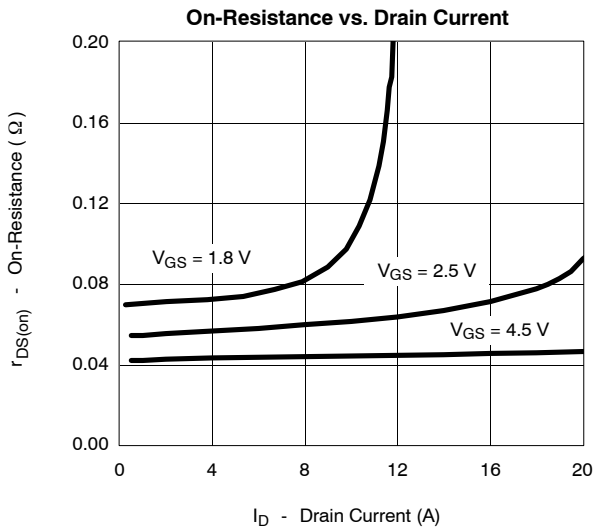
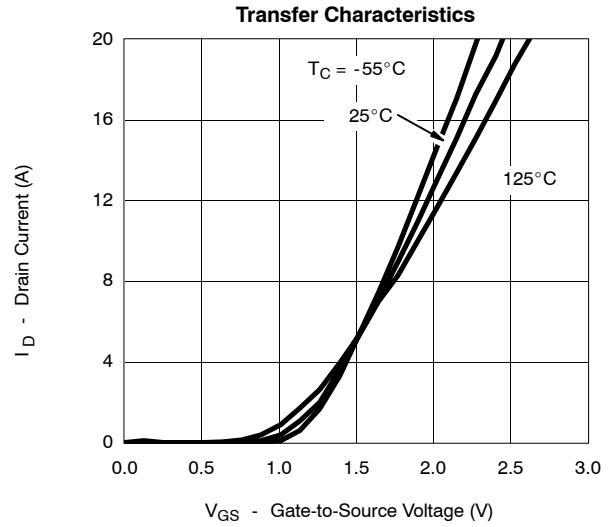
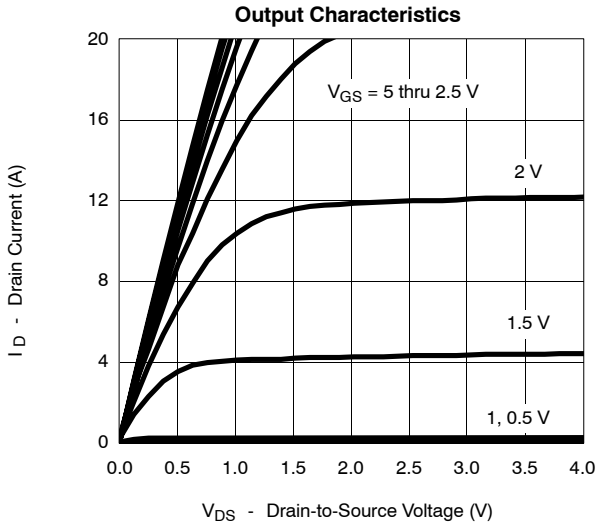

### TYPICAL CHARACTERISTICS (25 °C UNLESS NOTED)

### MOSFET

Source-Drain Diode Forward Voltage

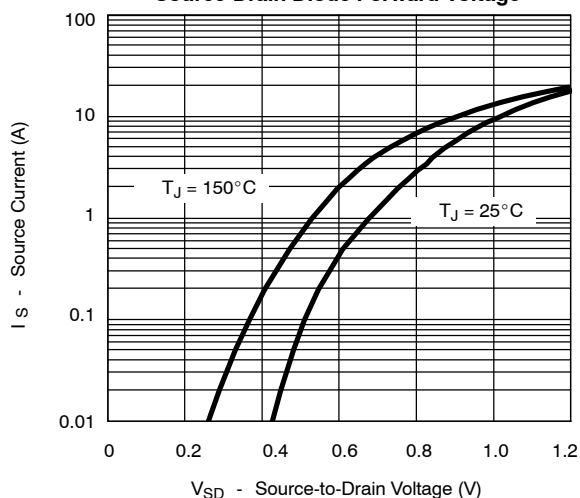

On-Resistance vs. Gate-to-Source Voltage

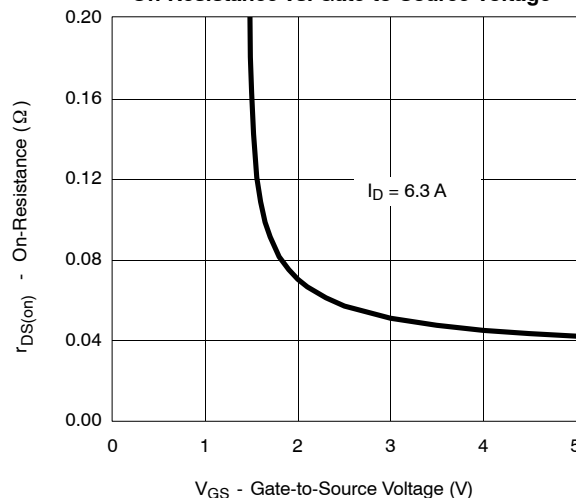

Threshold Voltage

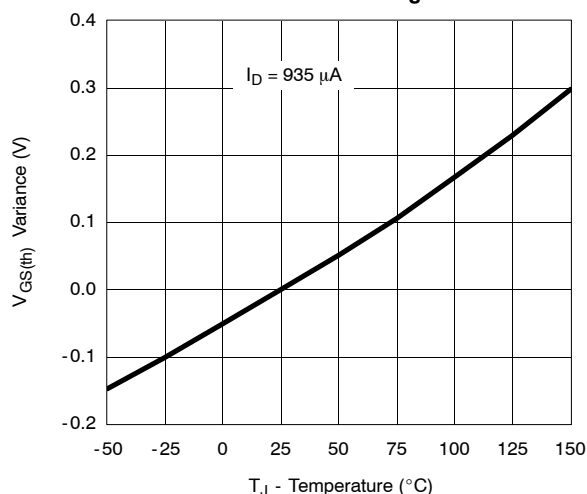

Single Pulse Power, Junction-to-Ambient

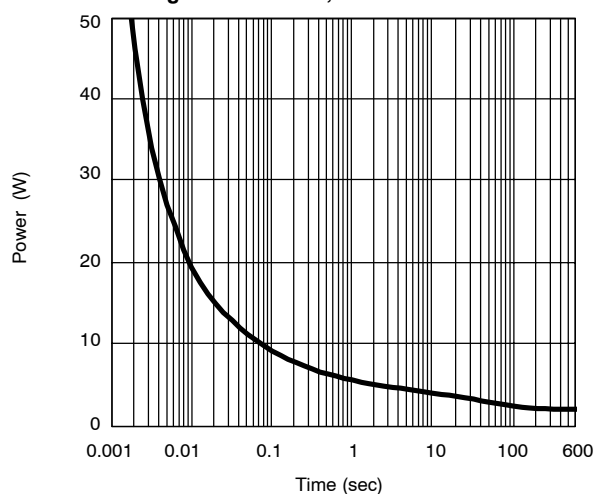

Normalized Thermal Transient Impedance, Junction-to-Ambient

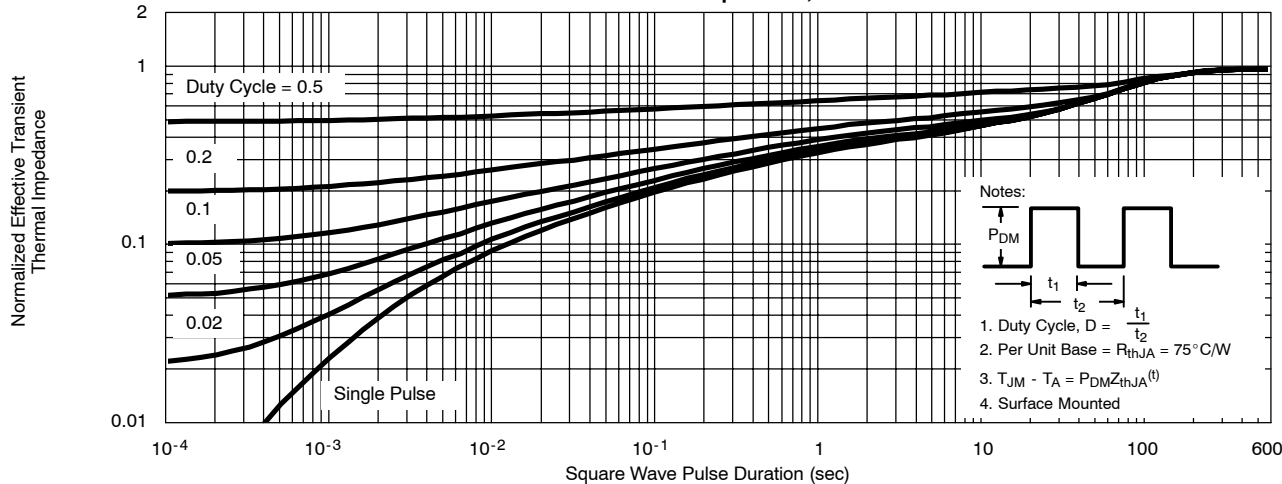



**TYPICAL CHARACTERISTICS (25°C UNLESS NOTED)**

**MOSFET**

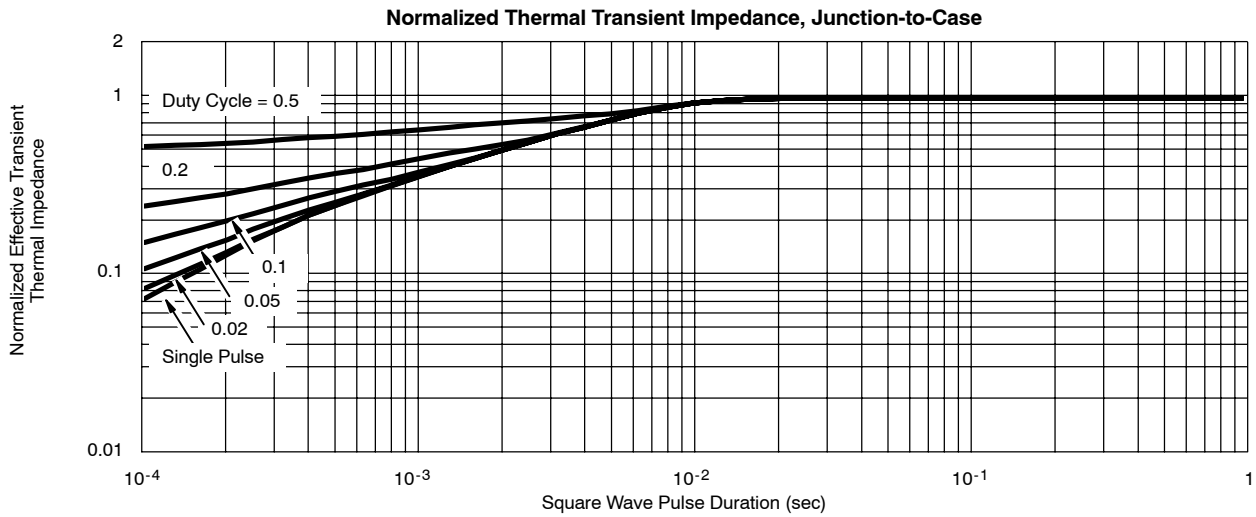

**TYPICAL CHARACTERISTICS (25°C UNLESS NOTED)**

**SCHOTTKY**

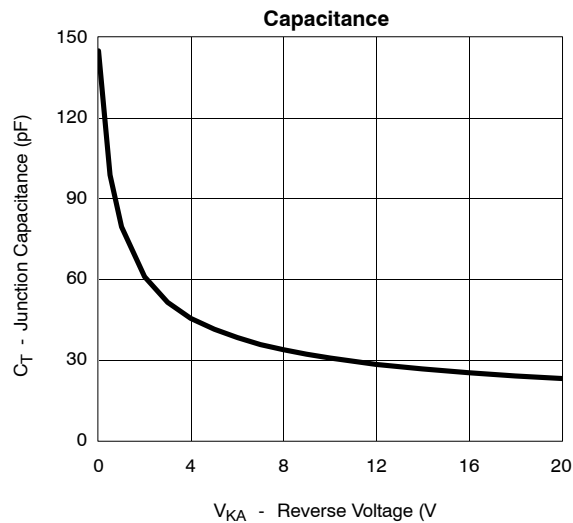
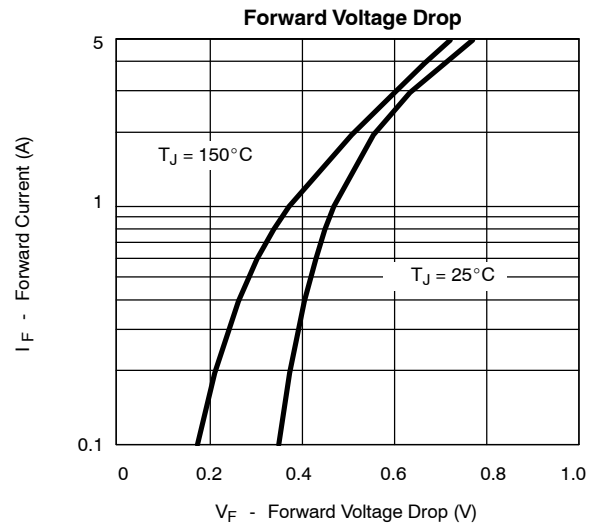
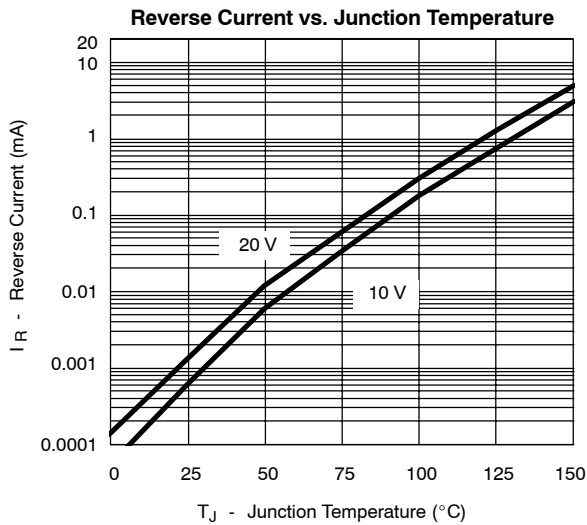

**TYPICAL CHARACTERISTICS (25 °C UNLESS NOTED)**

**SCHOTTKY**

