

N- and P-Channel 12-V (D-S) MOSFET

PRODUCT SUMMARY			
	V _{DS} (V)	r _{DS(on)} (Ω)	I _D (A)
N-Channel	12	0.017 @ V _{GS} = 4.5 V	11.8
		0.025 @ V _{GS} = 2.5 V	9.8
P-Channel	-12	0.032 @ V _{GS} = -4.5 V	-8.9
		0.053 @ V _{GS} = -2.5 V	-6.9

FEATURES

- TrenchFET® Power MOSFET
- New Low Thermal Resistance PowerPAK® Package with Low 1.07-mm Profile
- PWM Optimized for High Efficiency
- 100% R_g Tested

APPLICATIONS

- Point-of-Load Synchronous Rectifier
 - 5-V or 3.3-V BUS Step Down
 - Q_g Optimized for 500-kHz Operation
- Synchronous Buck, Shoot-Thru Resistant

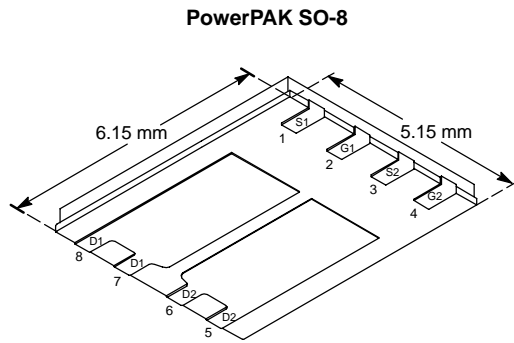

Bottom View

Ordering Information: Si7540DP-T1

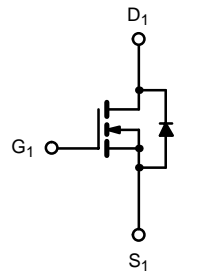

N-Channel MOSFET

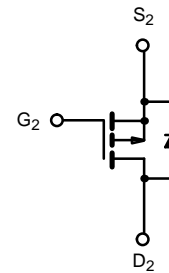

P-Channel MOSFET

ABSOLUTE MAXIMUM RATINGS (T_A = 25°C UNLESS OTHERWISE NOTED)

Parameter	Symbol	N-Channel		P-Channel		Unit	
		10 secs	Steady State	10 secs	Steady State		
Drain-Source Voltage	V _{DS}	12		-12		V	
Gate-Source Voltage	V _{GS}	±8		±8			
Continuous Drain Current (T _J = 150°C) ^a	I _D	T _A = 25°C	11.8	7.6	-8.9	-5.7	A
		T _A = 70°C	9.5	6.1	-7.1	-4.6	
Pulsed Drain Current	I _{DM}	20				A	
Continuous Source Current (Diode Conduction) ^a	I _S	2.9	1.1	-2.9	-1.1		
Maximum Power Dissipation ^a	P _D	T _A = 25°C	3.5	1.4	3.5	1.4	W
		T _A = 70°C	2.2	0.9	2.2	0.9	
Operating Junction and Storage Temperature Range	T _J , T _{stg}	-55 to 150				°C	

THERMAL RESISTANCE RATINGS

Parameter	Symbol	N-Channel		P-Channel		Unit	
		Typ	Max	Typ	Max		
Maximum Junction-to-Ambient ^a	R _{thJA}	t ≤ 10 sec	26	35	26	35	°C/W
		Steady State	60	85	60	85	
Maximum Junction-to-Case (Drain)	R _{thJC}	3.9	5.5	3.9	5.5		

Notes

a. Surface Mounted on 1" x 1" FR4 Board.

SPECIFICATIONS (T _J = 25 °C UNLESS OTHERWISE NOTED)							
Parameter	Symbol	Test Condition		Min	Typ	Max	Unit
Static							
Gate Threshold Voltage	V _{GS(th)}	V _{DS} = V _{GS} , I _D = 250 μA	N-Ch	0.6		1.5	V
		V _{DS} = V _{GS} , I _D = -250 μA	P-Ch	-0.6		-1.5	
Gate-Body Leakage	I _{GSS}	V _{DS} = 0 V, V _{GS} = ±8 V	N-Ch			±100	nA
		V _{DS} = 0 V, V _{GS} = ±8 V	P-Ch			±100	
Zero Gate Voltage Drain Current	I _{DSS}	V _{DS} = 9.6 V, V _{GS} = 0 V	N-Ch			1	μA
		V _{DS} = -9.6 V, V _{GS} = 0 V	P-Ch			-1	
		V _{DS} = 9.6 V, V _{GS} = 0 V, T _J = 55 °C	N-Ch			5	
		V _{DS} = -9.6 V, V _{GS} = 0 V, T _J = 55 °C	P-Ch			-5	
On-State Drain Current ^a	I _{D(on)}	V _{DS} ≥ 5 V, V _{GS} = 4.5 V	N-Ch	20			A
		V _{DS} ≤ -5 V, V _{GS} = -4.5 V	P-Ch	-20			
Drain-Source On-State Resistance ^a	r _{DS(on)}	V _{GS} = 4.5 V, I _D = 11.8 A	N-Ch		0.014	0.017	Ω
		V _{GS} = -4.5 V, I _D = -8.9 A	P-Ch		0.026	0.032	
		V _{GS} = 2.5 V, I _D = 9.8 A	N-Ch		0.020	0.025	
		V _{GS} = -2.5 V, I _D = -6.9 A	P-Ch		0.043	0.053	
Forward Transconductance ^a	g _{fs}	V _{DS} = 5 V, I _D = 11.8 A	N-Ch		32		S
		V _{DS} = -5 V, I _D = -8.9 A	P-Ch		23		
Diode Forward Voltage ^a	V _{SD}	I _S = 2.9 A, V _{GS} = 0 V	N-Ch		0.77	1.2	V
		I _S = -2.9 A, V _{GS} = 0 V	P-Ch		-0.8	-1.2	
Dynamic^b							
Total Gate Charge	Q _g	N-Channel V _{DS} = 6 V, V _{GS} = 4.5 V, I _D = 11.8 A P-Channel V _{DS} = -6 V, V _{GS} = -4.5 V, I _D = -8.9 A	N-Ch		11.5	17	nC
Gate-Source Charge	Q _{gs}		N-Ch		3.2		
			P-Ch		4.1		
Gate-Drain Charge	Q _{gd}		N-Ch		2.5		
		P-Ch		1.9			
Gate Resistance	R _g		N-Ch	0.5	1.7	2.5	Ω
			P-Ch	1.5	3.5	5.6	
Turn-On Delay Time	t _{d(on)}		N-Ch		30	45	ns
			P-Ch		35	55	
Rise Time	t _r	N-Channel V _{DD} = 6 V, R _L = 6 Ω I _D ≅ 1 A, V _{GEN} = 4.5 V, R _G = 6 Ω	N-Ch		50	75	
		P-Channel V _{DD} = -6 V, R _L = 6 Ω I _D ≅ -1 A, V _{GEN} = -4.5 V, R _G = 6 Ω	P-Ch		42	65	
Turn-Off Delay Time	t _{d(off)}	N-Channel V _{DD} = -6 V, R _L = 6 Ω I _D ≅ -1 A, V _{GEN} = -4.5 V, R _G = 6 Ω	N-Ch		60	90	
		P-Channel V _{DD} = -6 V, R _L = 6 Ω I _D ≅ -1 A, V _{GEN} = -4.5 V, R _G = 6 Ω	P-Ch		54	85	
Fall Time	t _f	N-Ch		25	40		
		P-Ch		17	30		
Source-Drain Reverse Recovery Time	t _{rr}	I _F = 2.9 A, di/dt = 100 A/μs	N-Ch		40	80	
		I _F = -2.9 A, di/dt = 100 A/μs	P-Ch		40	80	

Notes

- a. Pulse test; pulse width ≤ 300 μs, duty cycle ≤ 2%.
 b. Guaranteed by design, not subject to production testing.



TYPICAL CHARACTERISTICS (25°C UNLESS NOTED)

N-CHANNEL

Output Characteristics

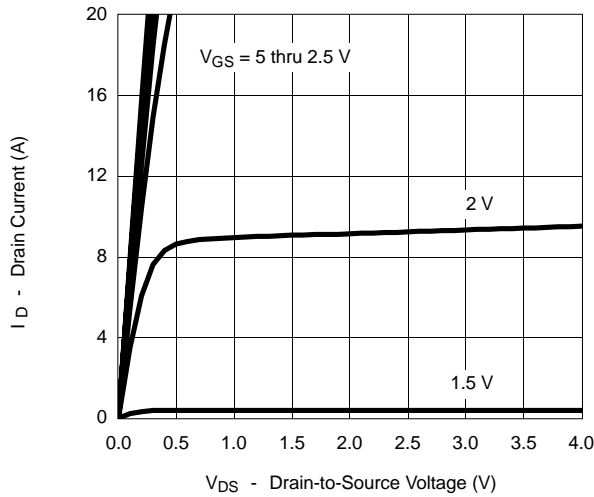

Transfer Characteristics

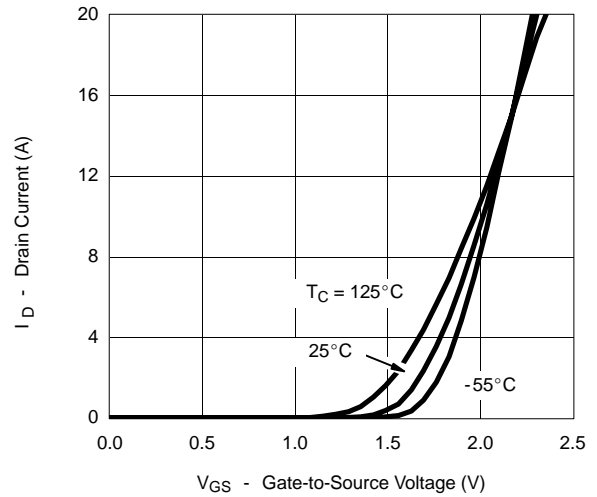

On-Resistance vs. Drain Current

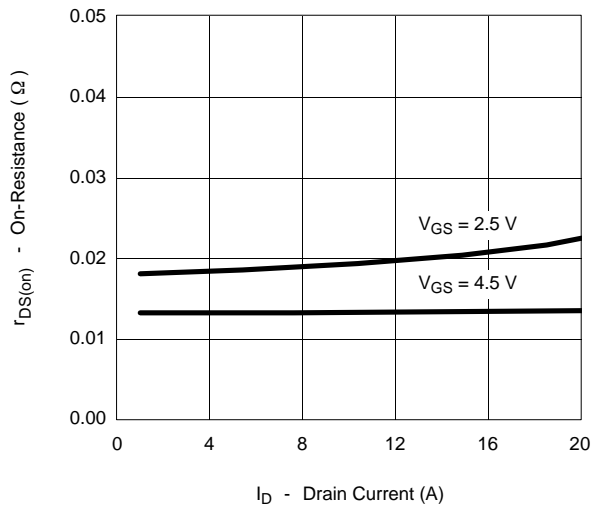

Capacitance

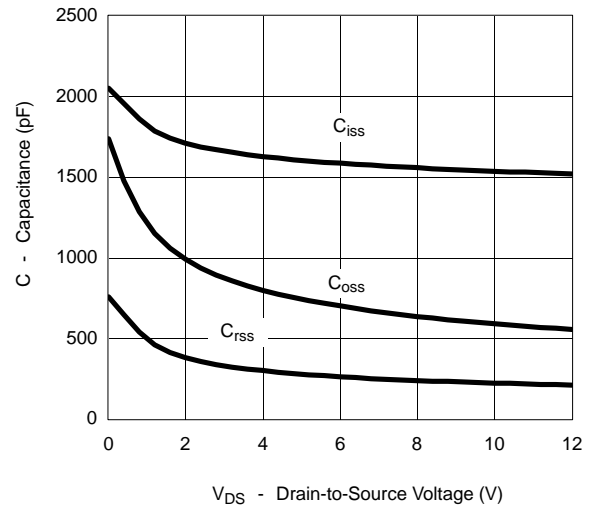

Gate Charge

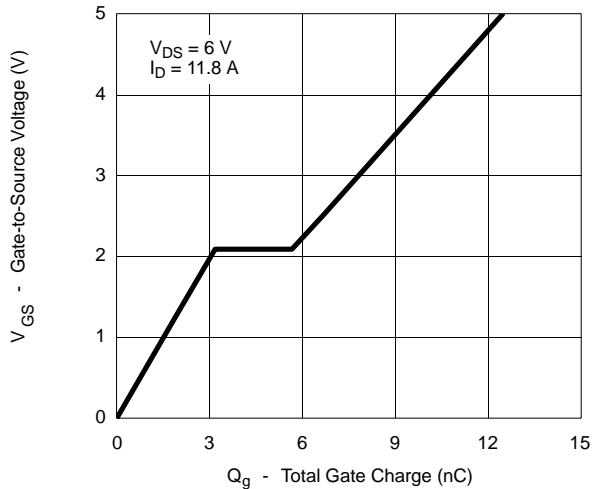

On-Resistance vs. Junction Temperature

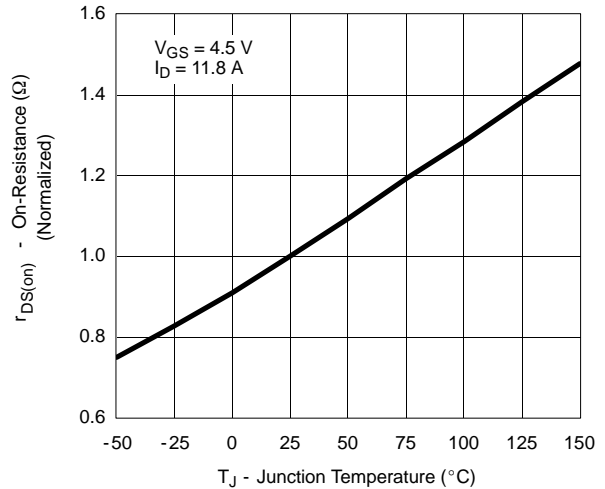

TYPICAL CHARACTERISTICS (25 °C UNLESS NOTED) N-CHANNEL

Source-Drain Diode Forward Voltage

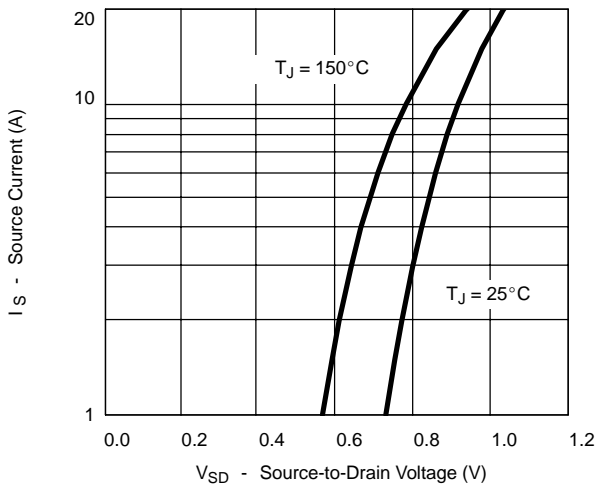

On-Resistance vs. Gate-to-Source Voltage

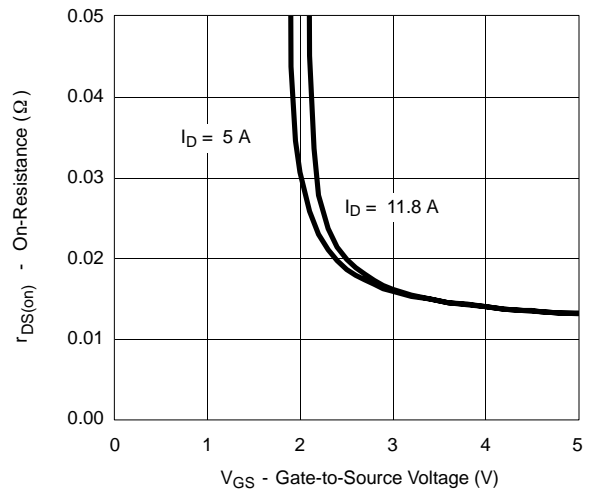

Threshold Voltage

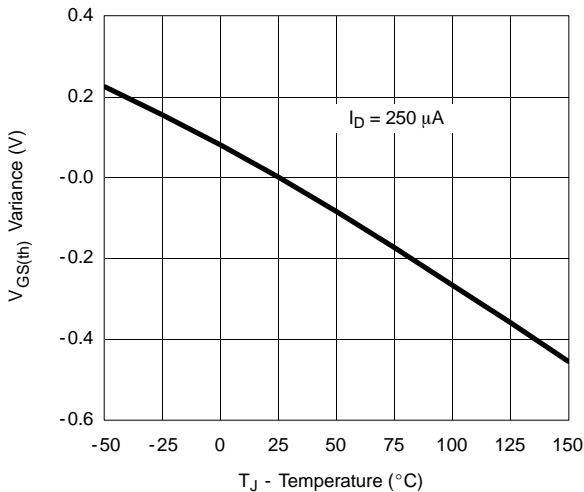

Single Pulse Power

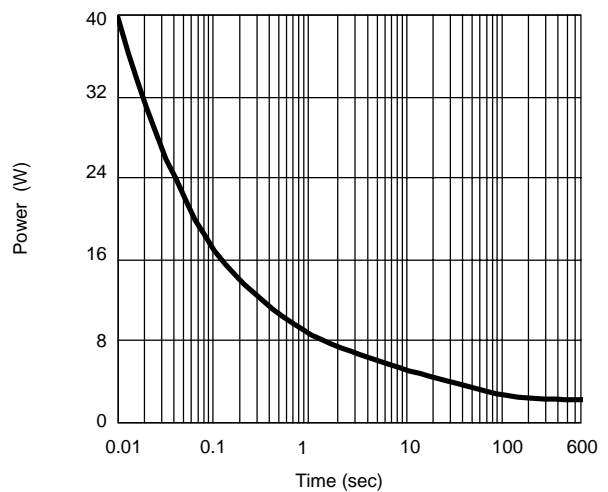

Safe Operating Area, Junction-To-Ambient

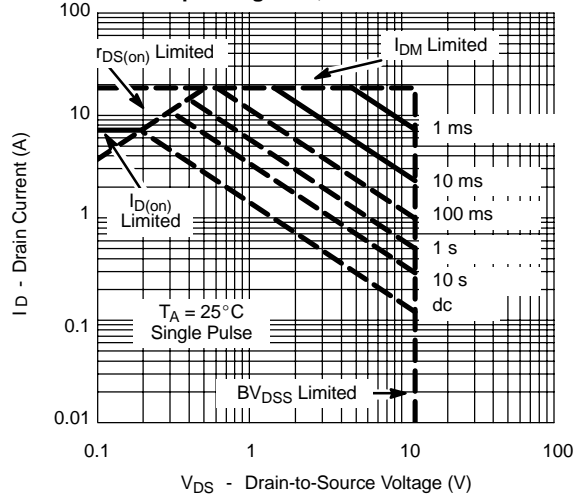



TYPICAL CHARACTERISTICS (25°C UNLESS NOTED)

N-CHANNEL

Normalized Thermal Transient Impedance, Junction-to-Ambient

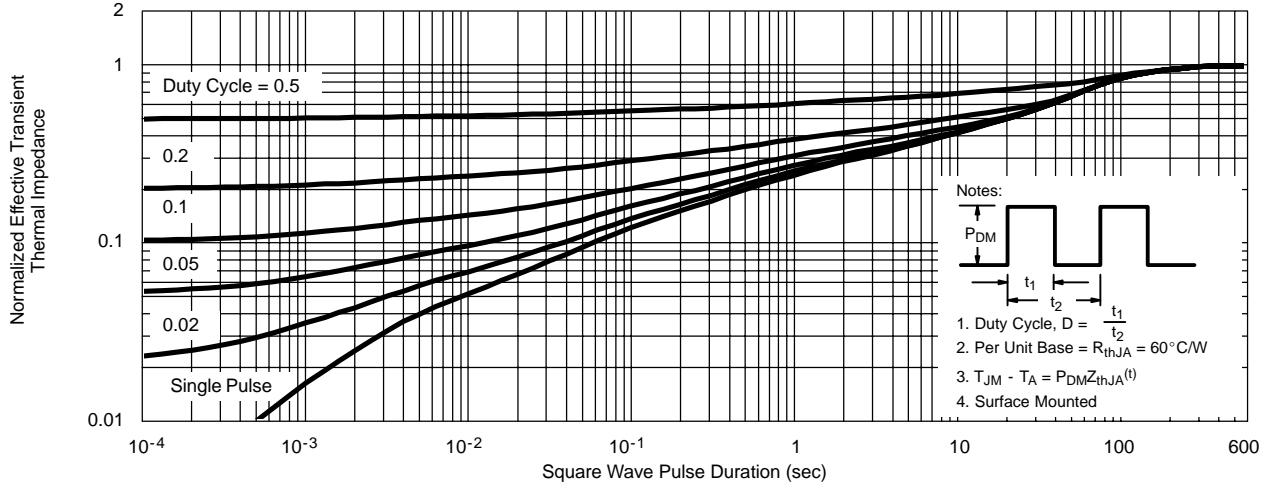

Normalized Thermal Transient Impedance, Junction-to-Case

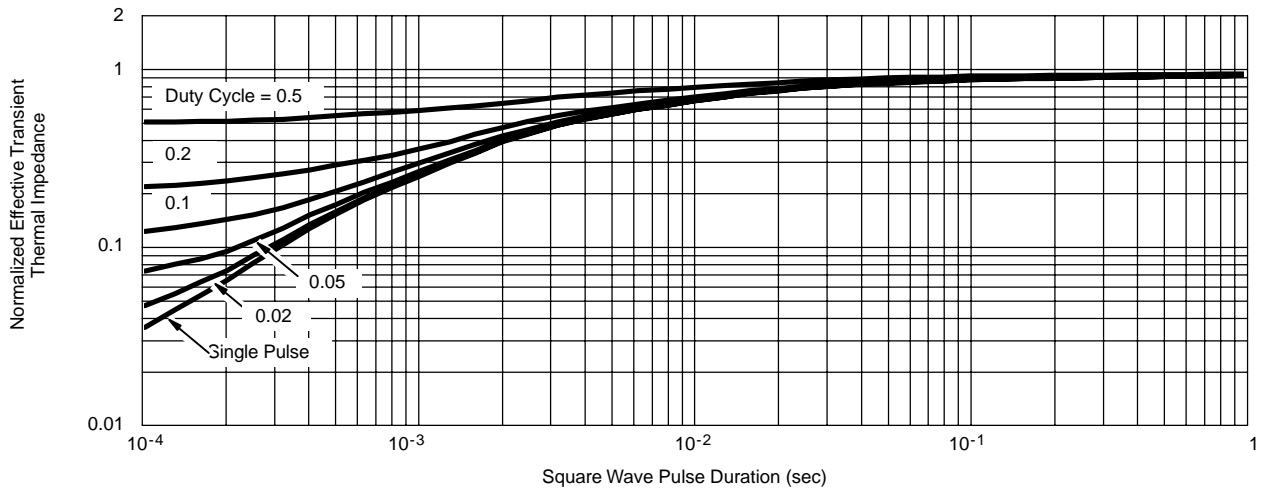

TYPICAL CHARACTERISTICS (25°C UNLESS NOTED) P-CHANNEL

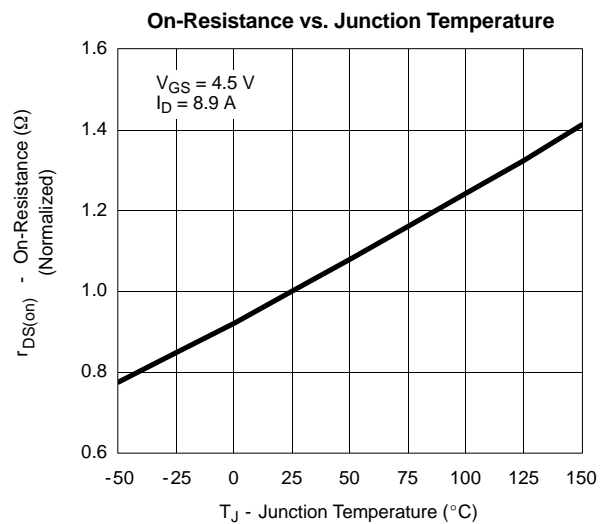
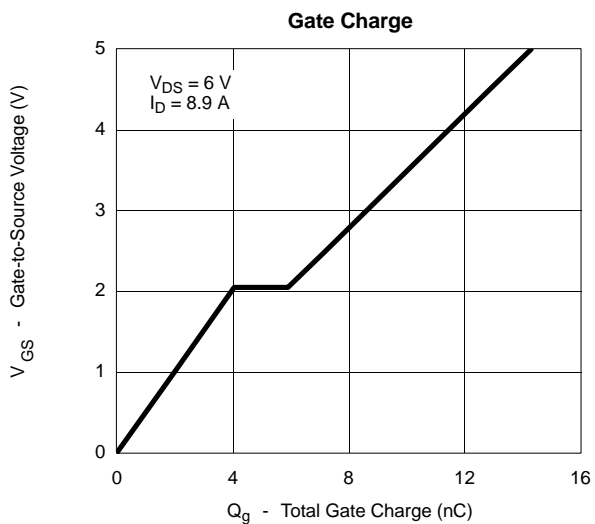
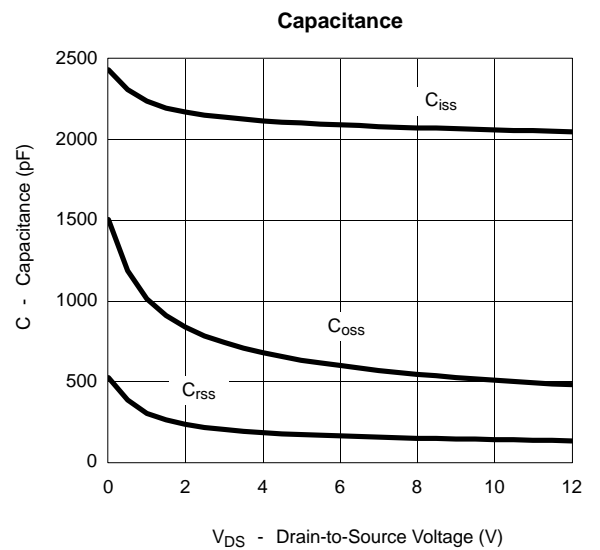
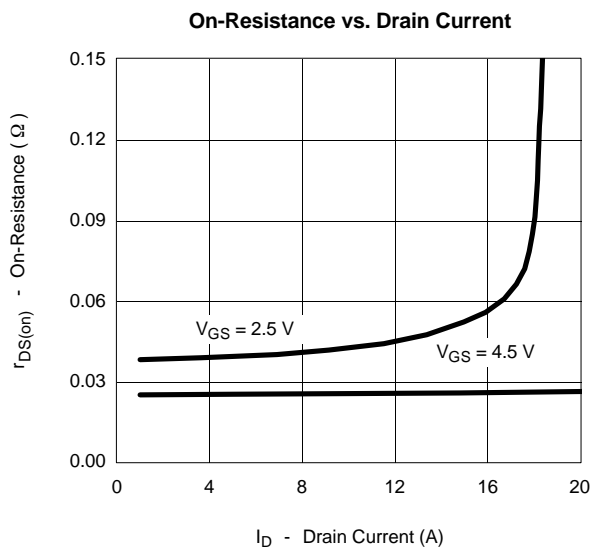
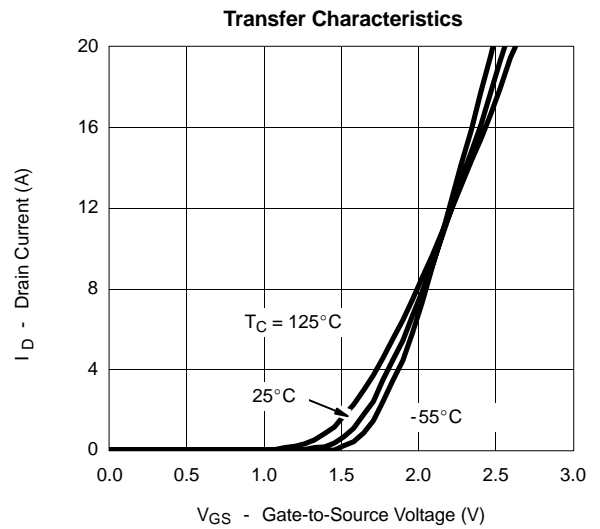
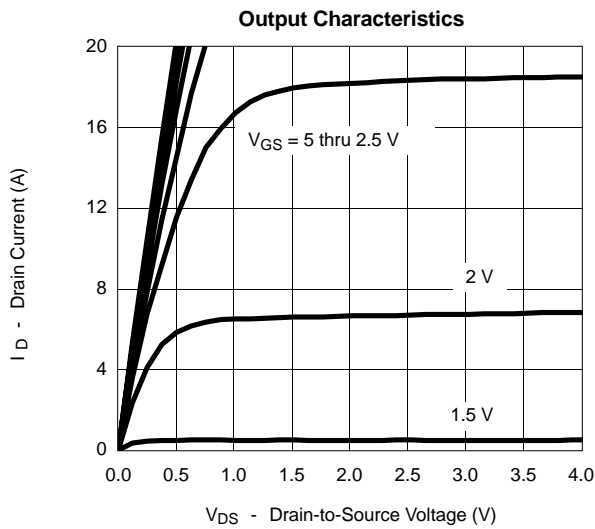

TYPICAL CHARACTERISTICS (25°C UNLESS NOTED)

P-CHANNEL

Source-Drain Diode Forward Voltage

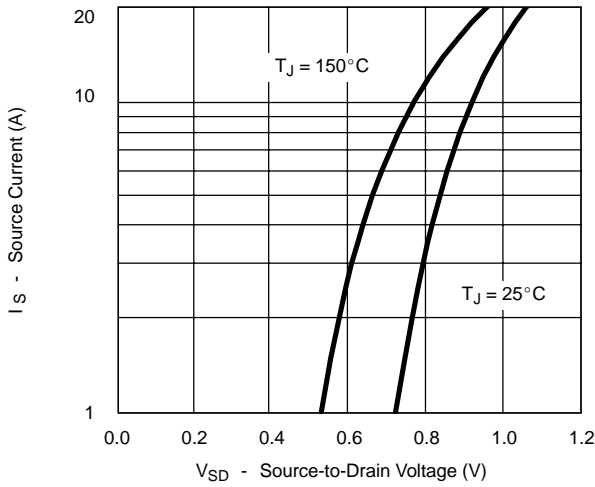

On-Resistance vs. Gate-to-Source Voltage

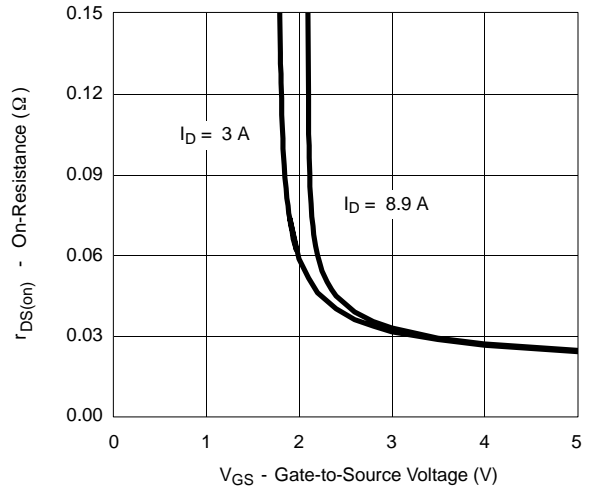

Threshold Voltage

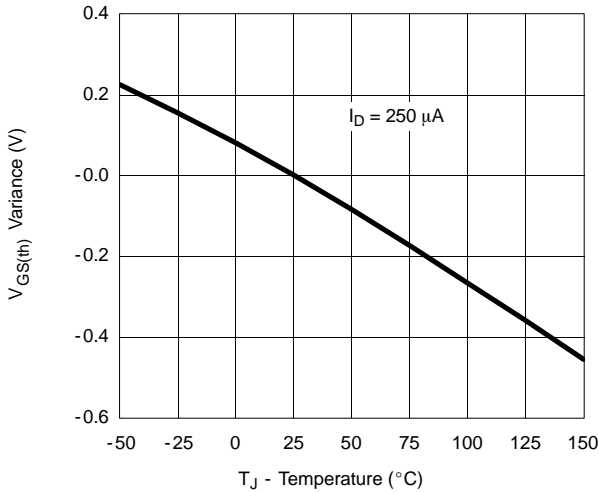

Single Pulse Power

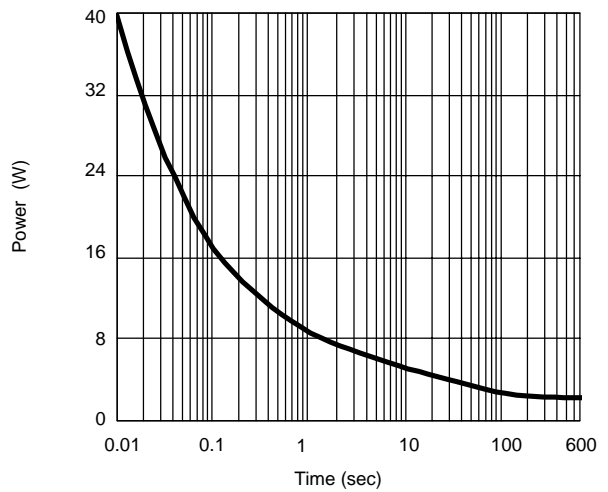

Safe Operating Area, Junction-To-Ambient

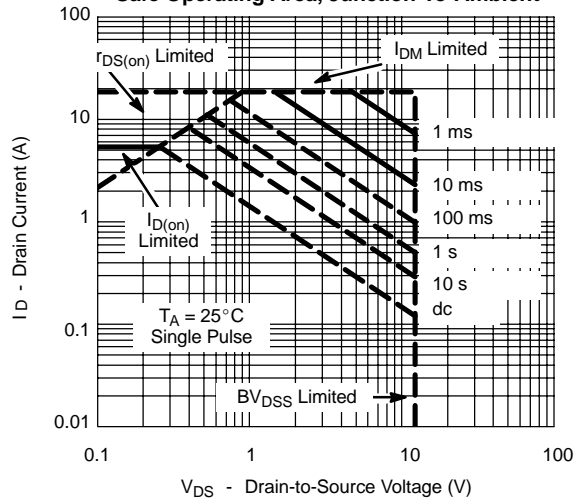

TYPICAL CHARACTERISTICS (25 °C UNLESS NOTED) P-CHANNEL

Normalized Thermal Transient Impedance, Junction-to-Ambient

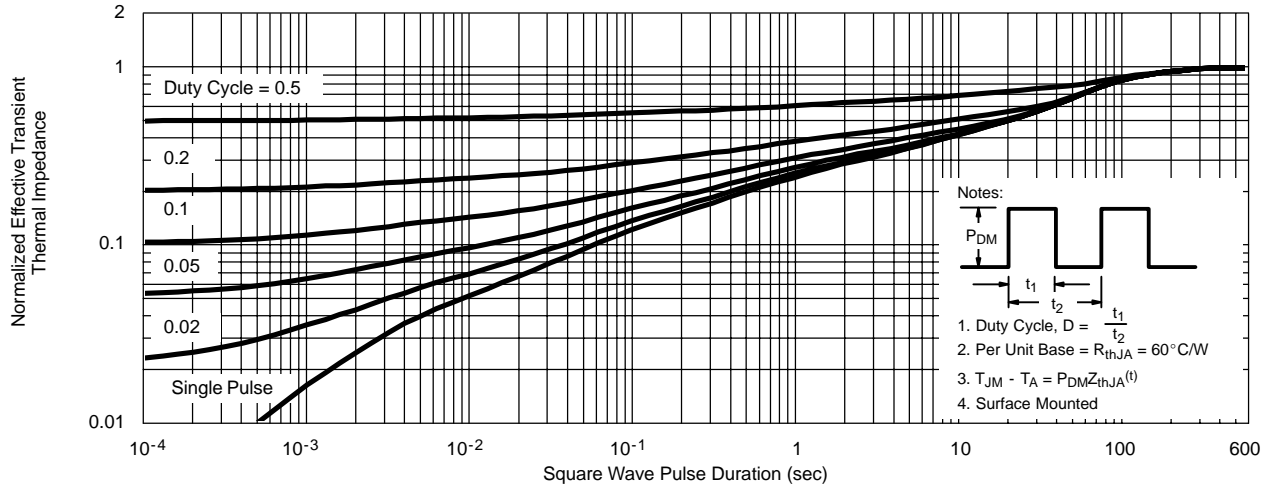

Normalized Thermal Transient Impedance, Junction-to-Case

