

AC Solid State Relay



S1

SERIES



Features

Medium power SSR with 25A load current (Max.)
 LED installed
 Dielectric strength between input and output at 3,000V/1 min.

UL, C-UL, TÜV standard approved
 Optional safety cover available (P83)
 Optional heat-sink available (P83)

Type Information

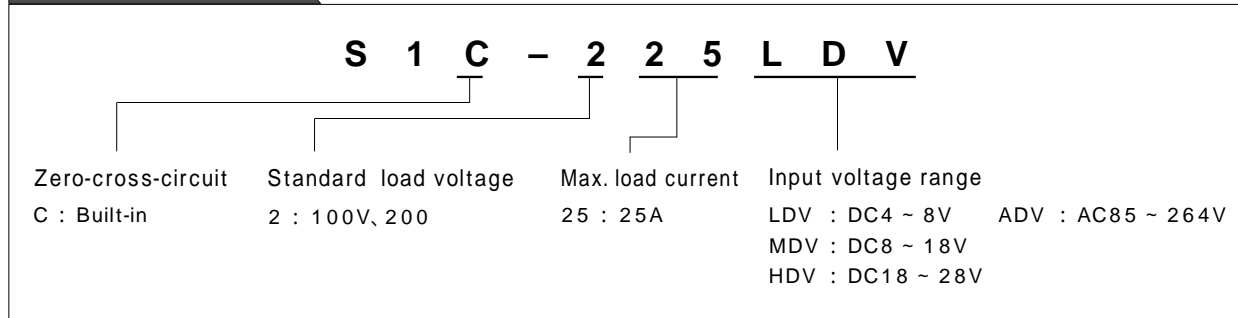

Characteristics

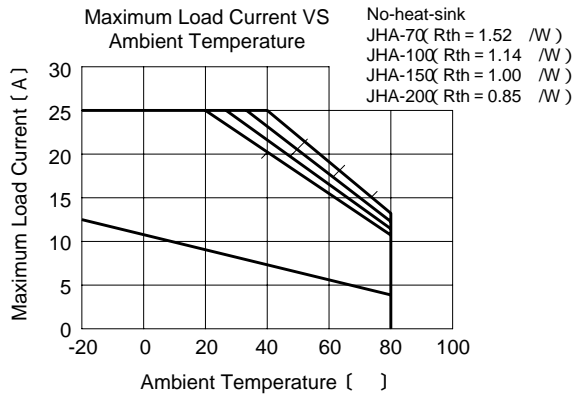

Description in the catalogue is subject to change without notice. Please read the specifications thoroughly before using. Please contact JEL SYSTEM for further information.

Dimensions (mm)

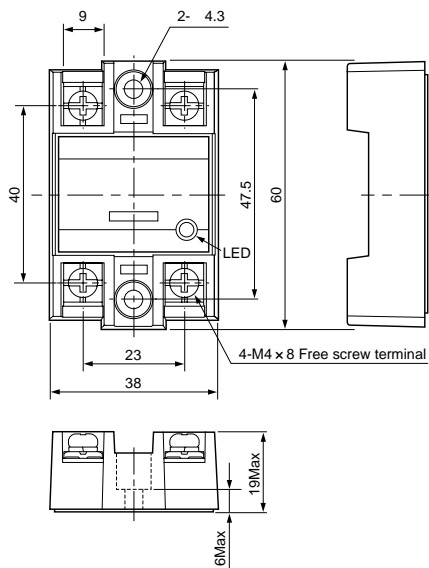

Torque range
 Output terminal 1.5 N · m(MAX)
 Input terminal 1.5 N · m(MAX)
 Outer case 1.5 N · m(MAX)

Equivalent Circuit

S1C-225LDV, S1C-225MDV, S1C-225HDV

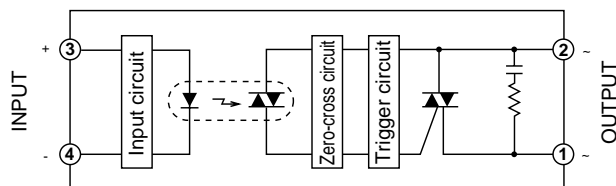

S1C-225ADV

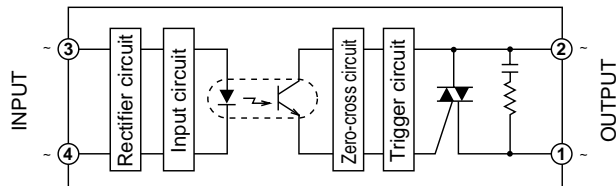

Description in the catalogue is subject to change without notice. Please read the specifications thoroughly before using.
 Please contact JEL SYSTEM for further information.

Ratings

(Ta = 25)

	Item	Symbols	S1C-225LDV	S1C-225MDV	S1C-225HDV	S1C-225ADV	Units
Output	Rated Load Voltage		120、240				V _{ACrms}
	Maximum Load Current	I _{OMAX}	25				A _{ACrms}
	Maximum Load Voltage	V _{OMAX}	264				V _{ACrms}
	Peak Repetitive Off State Voltage	V _{DRM}	600			V _{DSM} = 600 * 1	V
	Peak 1 Cycle Surge Current	I _{SURGE}	225 (50Hz)				A
	Frequency	f	50、60				Hz
Input	Maximum Input Voltage	V _{IMAX}	8	18	28	264(V _{ACrms})	V _{DC}
	Input Impedance	R _{IN}	220 ± 20 %	560 ± 20 %	1220 ± 20 %	5mA * 2	
General	Dielectric Strength	V _{ISO}	3,000 / 1 min. (Between input-output-case)(Rh40 ~ 60 %)				V _{ACrms}
	Isolation Resistance	R _{ISO}	10 ⁸ and above DC500V (Between input-output-case)(Rh40 ~ 60 %)				
	Operating Temperature Range	T _{OPR}	- 20 ~ + 80				
	Storage Temperature Range	T _{STG}	- 30 ~ + 100				

* 1 Peak non-Repetitive Off State Voltage V_{DSM} * 2 Max. input current

Electrical Characteristics

(Ta = 25)

	Item	Symbols	S1C-225LDV	S1C-225MDV	S1C-225HDV	S1C-225ADV	Units
Output	Load Voltage Range	V _O	85 ~ 264				V _{ACrms}
	Off State Leakage Current	I _{LEK}	12 and below (V _O = 200V)				mA _{ACrms}
	On State Voltage Drop	V _{SAT}	1.5 and below				V _{ACrms}
	Minimum Load Current	I _{OMIN}	100				mA
Input	Input Voltage Range	V _I	4 ~ 8	8 ~ 18	18 ~ 28	85 ~ 264(V _{ACrms})	V _{DC}
	Operate Voltage	V _P	4 and below	8 and below	18 and below	85 and below (V _{ACrms})	V _{DC}
	Release Voltage	V _D	1 and above			30 以上(V _{ACrms})	V _{DC}
General	Operate Time	T _{ON}	1/2 Cycle + 1 ms and below			1 + 1/2 Cycle + 1 ms and below	
	Release Time	T _{OFF}	1/2 Cycle + 1 ms and below			1 + 1/2 Cycle + 1 ms and below	
	Capacitance	C _{IO}	150 and below				PF
	Zero Cross Turn On		Built In				
	Approved Standards		UL、C-UL、TÜV				

Description in the catalogue is subject to change without notice. Please read the specifications thoroughly before using.
Please contact JEL SYSTEM for further information.

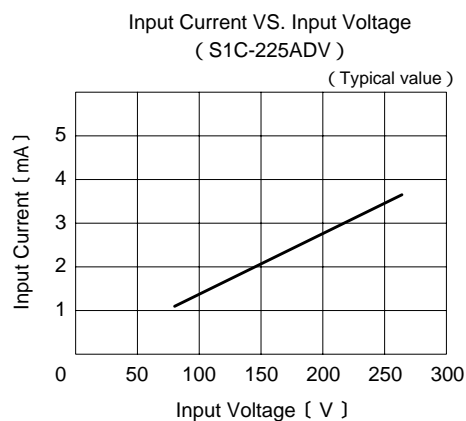
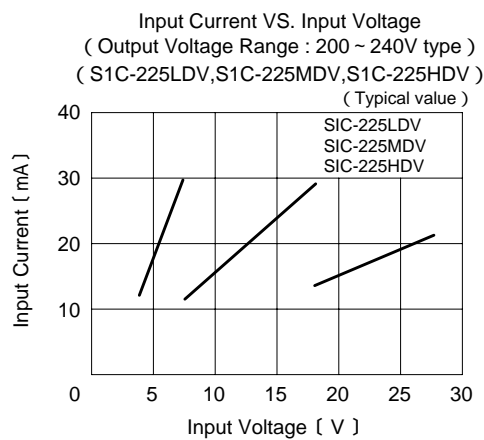
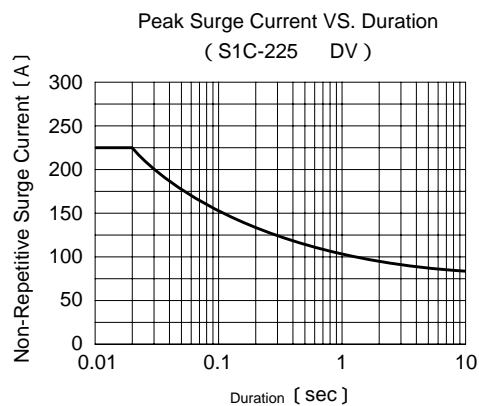

Description in the catalogue is subject to change without notice. Please read the specifications thoroughly before using.
Please contact JEL SYSTEM for further information.

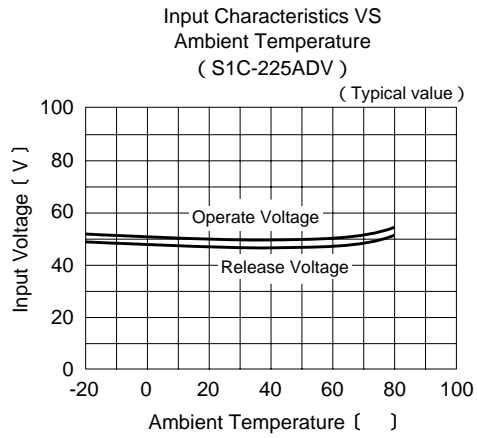
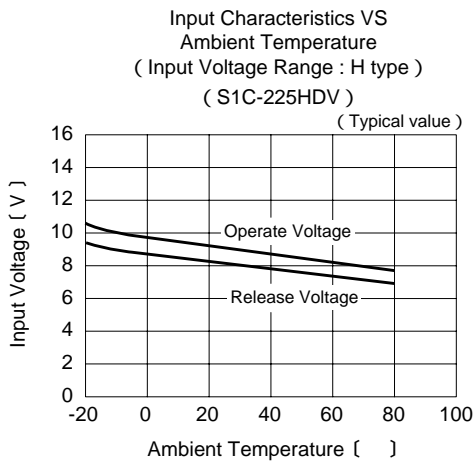
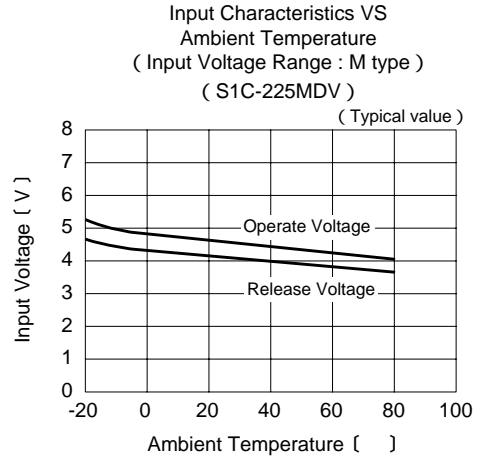
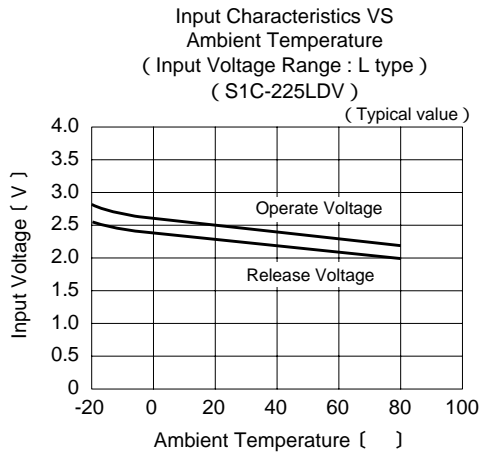

Description in the catalogue is subject to change without notice. Please read the specifications thoroughly before using.
Please contact JEL SYSTEM for further information.

Option

Heat-sink

Model	JHC-38-1
SUITABLE SSR	S1C Series

Dimensions

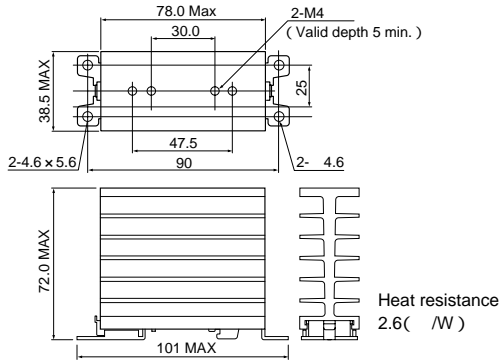

Maximum Load Current VS Ambient Temperature

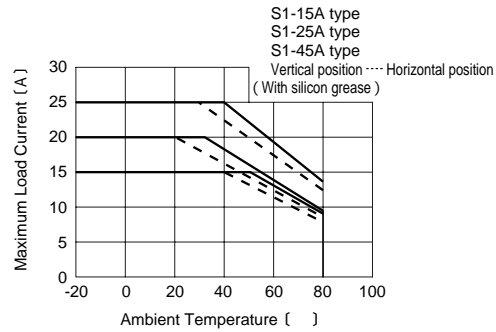

Model	JHA-
SUITABLE SSR	S1C Series

Dimensions

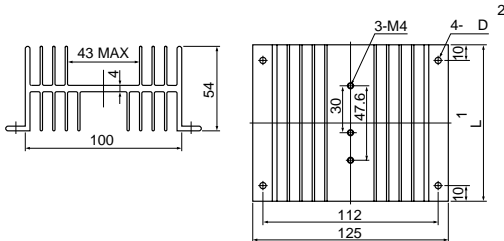

Model	Heat Resistance (/W)	1 L(mm) Dimensions	2 D(mm) Dimensions
JHA-70	1.52	70	4
JHA-100	1.14	100	4
JHA-150	1.00	150	4.5
JHA-200	0.85	200	4

Safety cover

Model	CV-S101
SUITABLE SSR	S1C Series

Dimensions

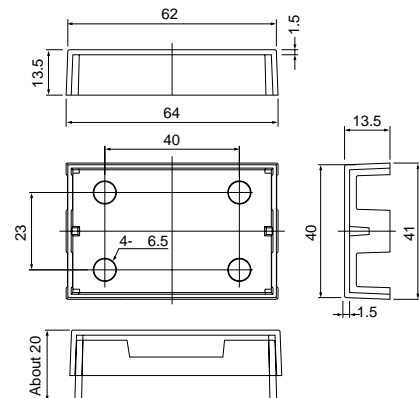

Description in the catalogue is subject to change without notice. Please read the specifications thoroughly before using.
Please contact JEL SYSTEM for further information.