



# High-Voltage, High-Power LED Driver with Analog and PWM Dimming Control

## General Description

The MAX16831 is a current-mode, high-brightness LED (HBLED) driver designed to control two external n-channel MOSFETs for the single-string LED current regulation. The MAX16831 integrates all the building blocks necessary to implement fixed-frequency HBLED drivers with wide-range dimming control. The MAX16831 is configurable to operate as a step-down (buck), step-up (boost), or step-up/-down (buck-boost) current regulator.

Current-mode control with leading-edge blanking simplifies control-loop design. Internal slope compensation stabilizes the current loop when operating at duty cycles above 50%. The MAX16831 operates over a wide input voltage range and is capable of withstanding automotive load-dump events. Multiple MAX16831s can be synchronized to each other or to an external clock. The MAX16831 includes a floating dimming driver for brightness control with an external n-channel MOSFET in series with the LED string.

HBLED drivers using the MAX16831 achieve efficiencies of over 90% in automotive applications. The MAX16831 also includes a 1.4A source and 2.5A sink gate driver for driving switching MOSFETs in high-power LED driver applications, such as front light assemblies. The dimming control allows for wide PWM dimming at frequencies up to 2kHz. Higher dimming ratios of up to 1000:1 are achievable at lower dimming frequencies.

The MAX16831 is available in a 32-pin thin QFN package with exposed pad and operates over the  $-40^{\circ}\text{C}$  to  $+125^{\circ}\text{C}$  automotive temperature range.

## Applications

Automotive Exterior Lighting:  
 High-Beam/Low-Beam/Signal Lights  
 Rear Combination Lights (RCL)  
 Daytime Running Lights (DRL)  
 Fog Light and Adaptive Front Light Assemblies

Industrial and Architectural Lighting  
 Emergency Lighting  
 Projectors with RGB LED Light Sources  
 Navigation and Marine Indicators

Pin Configuration appears at end of data sheet.

## Features

- ◆ Wide Input Range: 6V to 76V With Cold-Start Operation to 5.5V
- ◆ Integrated Differential LED Current-Sense Amplifier
- ◆ Floating Dimming Driver Capable of Driving an n-Channel MOSFET
- ◆ 5% LED Current Accuracy
- ◆ 200Hz On-Board Ramp Syncs to External PWM Dimming Signal
- ◆ Programmable Switching Frequency (125kHz to 600kHz) and Synchronization
- ◆ Output Overvoltage Load Dump, LED Short, Overtemperature Protection
- ◆ Low 107mV LED Current Sense for High Efficiency
- ◆ Enable/Shutdown Input with Shutdown Current Below 45 $\mu\text{A}$

## Ordering Information

PART	TEMP RANGE	PIN-PACKAGE	PKG CODE
MAX16831ATJ+	$-40^{\circ}\text{C}$ to $+125^{\circ}\text{C}$	32 TQFN-EP*	T3255M-4

+ Denotes lead-free package.

\*EP = Exposed pad.

## Typical Operating Circuits

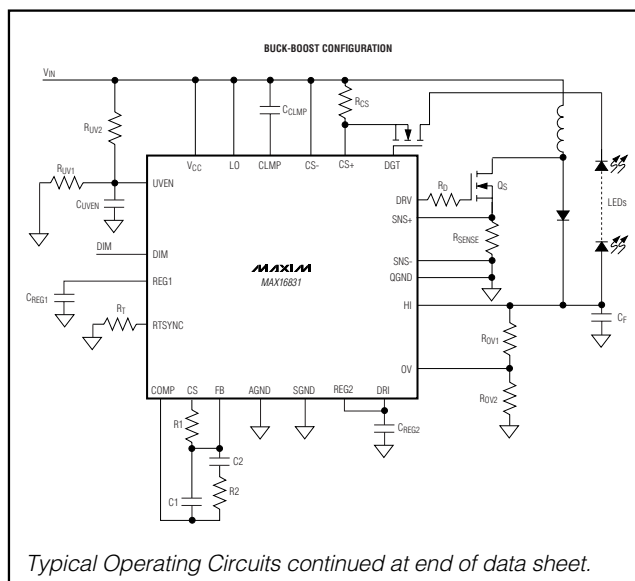

MAX16831

# High-Voltage, High-Power LED Driver with Analog and PWM Dimming Control

## ABSOLUTE MAXIMUM RATINGS

V <sub>CC</sub> , HI, LO, CLMP to QGND	-0.3V to +80V	CS+, CS-, DGT, CLMP to LO	-0.3V to (HI + 0.3V)
CS+, CS-, DGT, UVEN to QGND	-0.3V to +80V	HI to CLMP	-0.3V to +28V
UVEN to QGND	-0.3V to (V <sub>CC</sub> + 0.3V)	Continuous Power Dissipation* (T <sub>A</sub> = +70°C)	
DRV to SGND	-0.3V to +18V	32-Pin TQFN (derate 34.5mW/°C above +70°C)	2758mW
DRI, REG2, DIM to AGND	-0.3V to +18V	Thermal Resistance*	
QGND, SGND to AGND	-0.3V to +0.3V	θ <sub>JA</sub>	29°C/W
SNS+ to SNS-	-0.3V to +6V	θ <sub>JC</sub>	1.7°C/W
CS, FB, COMP, SNS+, SNS-, OV, REF,		Operating Temperature Range	-40°C to +125°C
RTSYNC to AGND	-0.3V to +6V	Maximum Junction Temperature	+150°C
REG1, CLKOUT to AGND	-0.3V to +6V	Storage Temperature Range	-60°C to +150°C
CS+ to CS-	-0.3V to +12V	Reflow Temperature	+240°C
HI to LO	-0.3V to +36V	Lead Temperature (soldering, 10s)	+300°C
CS+, CS-, DGT, CLMP to LO	-0.3V to +12V	*As per JEDEC 51 standard, multilayer board (PCB).	

Stresses beyond those listed under "Absolute Maximum Ratings" may cause permanent damage to the device. These are stress ratings only, and functional operation of the device at these or any other conditions beyond those indicated in the operational sections of the specifications is not implied. Exposure to absolute maximum rating conditions for extended periods may affect device reliability.

## ELECTRICAL CHARACTERISTICS

(V<sub>CC</sub> = V<sub>UVEN</sub> = 14V, C<sub>REG1</sub> = 1μF, C<sub>REG2</sub> = 1μF, C<sub>CLMP</sub> = 0.1μF, R<sub>T</sub> = 25kΩ, T<sub>A</sub> = T<sub>J</sub> = -40°C to +125°C, unless otherwise noted. Typical specifications are at T<sub>A</sub> = +25°C.)

PARAMETER	SYMBOL	CONDITIONS	MIN	TYP	MAX	UNITS
Input Voltage Range	V <sub>CC</sub>		5.5		76.0	V
Supply Current	I <sub>Q</sub>	I <sub>REG2</sub> = 0A		2.7	4.5	mA
Shutdown Current	I <sub>SHDN</sub>	V <sub>UVEN</sub> ≤ 0.8V		25	45	μA
<b>UVEN</b>						
V <sub>CC</sub> UVLO Threshold	V <sub>CC_R</sub>	V <sub>CC</sub> rising	5.5		6.0	V
	V <sub>CC_F</sub>	V <sub>CC</sub> falling	5.0		5.5	
V <sub>CC</sub> Threshold Hysteresis	V <sub>CC_HYS</sub>			0.4		V
UVEN Threshold	V <sub>UVR</sub>	V <sub>UVEN</sub> rising	1.100	1.244	1.360	V
	V <sub>UVF</sub>	V <sub>UVEN</sub> falling	1.000	1.145	1.260	
UVEN Input Current	I <sub>UVEN</sub>	V <sub>UVEN</sub> = 0V and V <sub>UVEN</sub> = 76V, V <sub>CC</sub> = 77V	-0.2		+0.2	μA
<b>REGULATORS</b>						
REG1 Regulator Output	V <sub>REG1</sub>	0 ≤ I <sub>REG1</sub> ≤ 2mA, 7.5V ≤ V <sub>CC</sub> ≤ 76V	4.75	5.00	5.25	V
		I <sub>REG1</sub> = 2mA, V <sub>CC</sub> = 5.7V	4.00	4.50	5.25	
REG1 Dropout Voltage		I <sub>REG1</sub> = 2mA (Note 1)		0.5	1.0	V
REG1 Load Regulation	ΔV/ΔI	V <sub>CC</sub> = 7.5V, 0 ≤ I <sub>REG1</sub> ≤ 2mA			25	Ω
REG2 Regulator Output	V <sub>REG2</sub>	7.5V ≤ V <sub>CC</sub> ≤ 76V, I <sub>REG2</sub> = 1mA	6.65	7.00	7.35	V
		V <sub>CC</sub> = 5.7V, 0 ≤ I <sub>REG2</sub> ≤ 20mA	4.5	5.0		
REG2 Dropout Voltage		I <sub>REG2</sub> = 20mA (Note 1)		0.5		V
REG2 Load Regulation	ΔV/ΔI	V <sub>CC</sub> = 7.5V, 0 ≤ I <sub>REG2</sub> ≤ 20mA			25	Ω
<b>HIGH-SIDE REGULATOR (CLMP) (All Voltages Referred to LO) (Note 2)</b>						
CLMP UVLO Threshold	V <sub>CLMPH</sub>	V <sub>CLMP</sub> rising	2.0	2.5	3.0	V
CLMP UVLO Threshold Hysteresis	V <sub>CLMPHYS</sub>			0.22		V

# High-Voltage, High-Power LED Driver with Analog and PWM Dimming Control

MAX16831

## ELECTRICAL CHARACTERISTICS (continued)

( $V_{CC} = V_{UVEN} = 14V$ ,  $C_{REG1} = 1\mu F$ ,  $C_{REG2} = 1\mu F$ ,  $C_{CLMP} = 0.1\mu F$ ,  $R_T = 25k\Omega$ ,  $T_A = T_J = -40^\circ C$  to  $+125^\circ C$ , unless otherwise noted. Typical specifications are at  $T_A = +25^\circ C$ .)

PARAMETER	SYMBOL	CONDITIONS	MIN	TYP	MAX	UNITS
CLMP Regulator Output Voltage	$V_{CLMP}$	$8.7V \leq (V_{HI} - V_{LO}) \leq 36V$ , $I_{CLMP} = 1mA$	5.5	8.0	10.0	V
		$5.0V \leq (V_{HI} - V_{LO}) \leq 8.7V$ , $I_{CLMP} = 250\mu A$	$(V_{HI} - V_{LO})$ -0.7			
<b>CURRENT-SENSE AMPLIFIER (CSA)</b>						
Differential Input Voltage Range	$V_{CS+} - V_{CS-}$		0		0.3	V
Common-Mode Range			0		$V_{CC}$	V
CS+ Input Bias Current	$I_{CS+}$	$V_{CS+} - V_{CS-} = 0.3V$	-250		+250	$\mu A$
CS- Input Bias Current	$I_{CS-}$	$V_{CS+} - V_{CS-} = 0.3V$			400	$\mu A$
Unity-Gain Bandwidth		From (CS+ - CS-) to CS		1.0		MHz
<b>REF OUTPUT BUFFER</b>						
REF Output Voltage	$V_{REF}$	$-100\mu A \leq I_{REF} \leq +100\mu A$	2.85	3.00	3.15	V
<b>DIM DRIVER</b>						
Source Current		$V_{CLMP} - V_{LO} = 4V$	5	20		mA
		$V_{CLMP} - V_{LO} = 8V$	30	67		
Sink Current		$V_{CLMP} - V_{LO} = 4V$	10	22		mA
		$V_{CLMP} - V_{LO} = 8V$	40	76		
<b>GATE DRIVER</b>						
DRI UVLO Threshold	$V_{UVLO\_TH}$	DRI rising	4.0	4.2	4.4	V
DRI UVLO Threshold Hysteresis	$V_{UVLO\_HYST}$			0.3		V
Driver Output Impedance	$Z_{OUT\_L}$	$V_{DRI} = 7.0V$ , DRV sinking 250mA		2.8	4	$\Omega$
	$Z_{OUT\_H}$	$V_{DRI} = 7.0V$ , DRV sourcing 250mA		5.0	8	
Peak Sink Current	$I_{SK}$	$V_{DRI} = 7.0V$		2.5		A
Peak Source Current	$I_{SR}$	$V_{DRI} = 7.0V$		1.4		A
<b>PWM, ILIM, AND HICCUP COMPARATOR</b>						
PWM Comparator Offset Voltage		$V_{COMP} - (V_{SNS+} - V_{SNS-})$		0.7		V
Peak Current-Limit Comparator Trip Threshold			160	200	240	mV
Peak Current-Limit Comparator Propagation Delay (Excluding Blanking Time)		50mV overdrive		40		ns
HICCUP Comparator Trip Threshold			235	300	385	mV
SNS+ Input Bias Current		$V_{SNS+} = 0V$ , $V_{SNS-} = 0V$	-100	-65		$\mu A$
SNS- Input Bias Current		$V_{SNS+} = 0V$ , $V_{SNS-} = 0V$	-100	-65		$\mu A$
Blanking Time	$t_{BLNK}$			40		ns

# High-Voltage, High-Power LED Driver with Analog and PWM Dimming Control

## ELECTRICAL CHARACTERISTICS (continued)

( $V_{CC} = V_{UVEN} = 14V$ ,  $C_{REG1} = 1\mu F$ ,  $C_{REG2} = 1\mu F$ ,  $C_{CLMP} = 0.1\mu F$ ,  $R_T = 25k\Omega$ ,  $T_A = T_J = -40^\circ C$  to  $+125^\circ C$ , unless otherwise noted. Typical specifications are at  $T_A = +25^\circ C$ .)

PARAMETER	SYMBOL	CONDITIONS	MIN	TYP	MAX	UNITS
<b>ERROR AMPLIFIER</b>						
FB Input Bias Current			-100		+100	nA
EAMP Output Sink Current		$V_{FB} = 1.735V$ , $V_{COMP} = 1V$	3	7		mA
EAMP Output Source Current		$V_{FB} = 0.735V$ , $V_{COMP} = 1V$	2	7		mA
EAMP Input Common-Mode Voltage			0		3.0	V
EAMP Output Clamp Voltage			1.1	1.7	2.4	V
Voltage Gain	$A_V$	$R_{COMP} = 100k\Omega$ to AGND		80		dB
Unity-Gain Bandwidth	GBW	$R_{COMP} = 100k\Omega$ to AGND, $C_{COMP} = 100pF$ to AGND		0.5		MHz
<b>OSCILLATOR, OSC SYNC, CLK, AND CLKOUT</b>						
RTSYNC Frequency Range	$f_{SWMIN}$				125	kHz
	$f_{SWMAX}$		500			
RTSYNC Oscillator Frequency		$R_T = 25k\Omega$	475	500	525	kHz
		$R_T = 100k\Omega$	106	125	143	
RTSYNC High-Level Voltage	$V_{SIHL}$		2.8			V
RTSYNC Low-Level Voltage	$V_{SILL}$				0.4	V
CLKOUT High Level		$I_{SINK} = 0.8mA$	2.8			V
CLKOUT Low Level		$I_{SOURCE} = 1.6mA$			0.4	V
CLKOUT Maximum Load Capacitance	$C_{CLK\_CAP}$	$f_{sw} = 500kHz$			500	pF
<b>DIM SYNC, DIM RAMP, AND DIM PWM GEN</b>						
Internal Ramp Frequency	$f_{RAMP}$		160	200	240	Hz
External Sync Frequency Range	$f_{DIM}$		80		2000	Hz
External Sync Low-Level Voltage	$V_{LTH}$		0.4			V
External Sync High-Level Voltage	$V_{HTH}$				3.2	V
DIM Comparator Offset	$V_{DIMOS}$		170	200	300	mV
<b>DIGITAL SOFT-START</b>						
Soft-Start Duration	$t_{SS}$			4.0		ms
<b>OVERVOLTAGE COMPARATOR, LOAD OVERCURRENT COMPARATOR</b>						
OVP Overvoltage Comparator Threshold	$V_{OV}$	$V_{OV}$ rising	1.20	1.235	1.27	V
OVP Overvoltage Comparator Hysteresis	$V_{OV\_HYST}$			63.5		mV
<b>SLOPE COMPENSATION</b>						
Slope Compensation Peak Voltage Per Cycle		Clock generated by $R_T$		120		mV
Slope Compensation		External clock applied to RTSYNC		15		mV/ $\mu s$

# High-Voltage, High-Power LED Driver with Analog and PWM Dimming Control

## ELECTRICAL CHARACTERISTICS (continued)

( $V_{CC} = V_{UVEN} = 14V$ ,  $C_{REG1} = 1\mu F$ ,  $C_{REG2} = 1\mu F$ ,  $C_{CLMP} = 0.1\mu F$ ,  $R_T = 25k\Omega$ ,  $T_A = T_J = -40^\circ C$  to  $+125^\circ C$ , unless otherwise noted. Typical specifications are at  $T_A = +25^\circ C$ .)

PARAMETER	SYMBOL	CONDITIONS	MIN	TYP	MAX	UNITS
<b>THERMAL SHUTDOWN</b>						
Thermal Shutdown Temperature	$T_{SHDN}$	Temperature rising		+165		$^\circ C$
Hysteresis	$\Delta T_{SHDN}$			20		$^\circ C$

**Note 1:** Dropout voltage is defined as the input to output differential voltage at which the regulator output voltage drops 100mV below the nominal output voltage.

**Note 2:**  $V_{CLMPH}$  determines the voltage required to operate the current-sense amplifier. The DIM driver requires 2.5V for ( $V_{CLMP} - V_{LO}$ ) to drive the external MOSFET.  $V_{HI}$  is typically one diode drop above  $V_{CLMP}$ . A large capacitor connected to  $V_{CLMP}$  slows the response of the LED current-sense circuitry, resulting in current overshoot. To ensure proper operation, connect a 0.1 $\mu F$  capacitor from CLMP to LO.

## Typical Operating Characteristics

( $V_{CC} = V_{UVEN} = 14V$ ,  $C_{REG1} = 1\mu F$ ,  $C_{REG2} = 10\mu F$ ,  $C_{CLMP} = 0.1\mu F$ ,  $R_T = 25k\Omega$ ,  $R_{CS} = 0.1\Omega$ ,  $T_A = +25^\circ C$ , unless otherwise noted.)

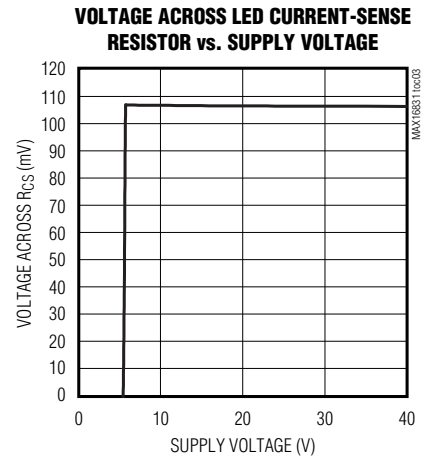
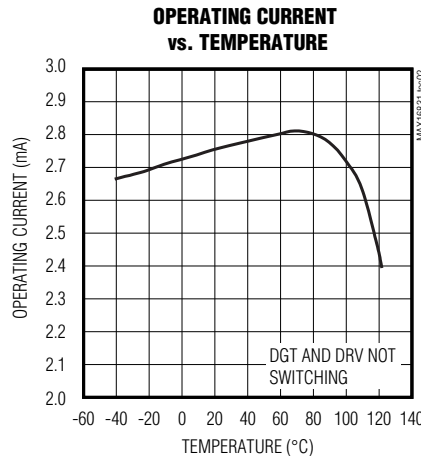
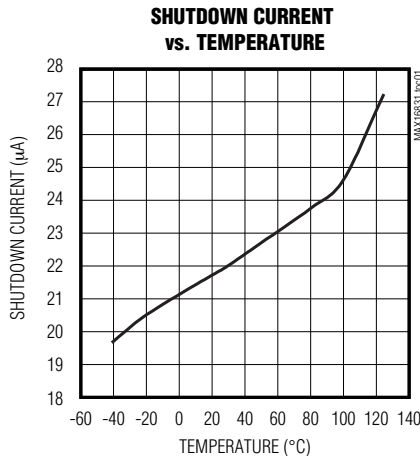

# High-Voltage, High-Power LED Driver with Analog and PWM Dimming Control

## Typical Operating Characteristics (continued)

( $V_{CC} = V_{UVEN} = 14V$ ,  $C_{REG1} = 1\mu F$ ,  $C_{REG2} = 10\mu F$ ,  $C_{CLMP} = 0.1\mu F$ ,  $R_T = 25k\Omega$ ,  $R_{CS} = 0.1\Omega$ ,  $T_A = +25^\circ C$ , unless otherwise noted.)

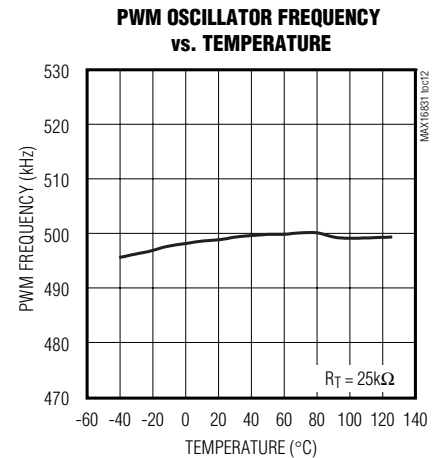
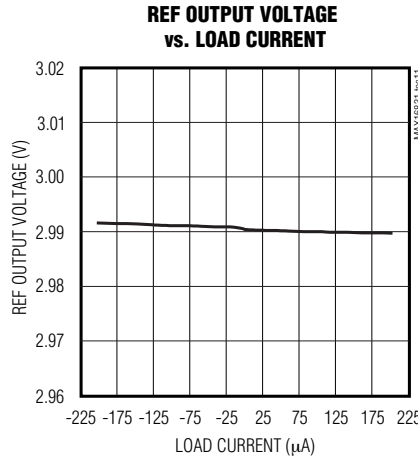
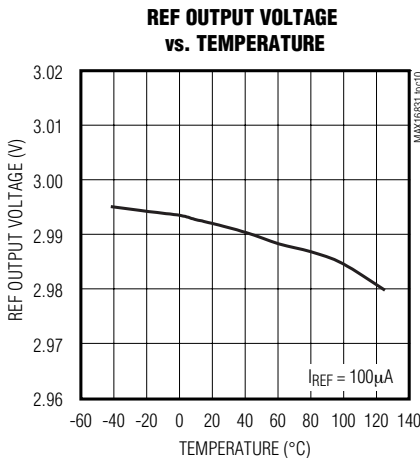
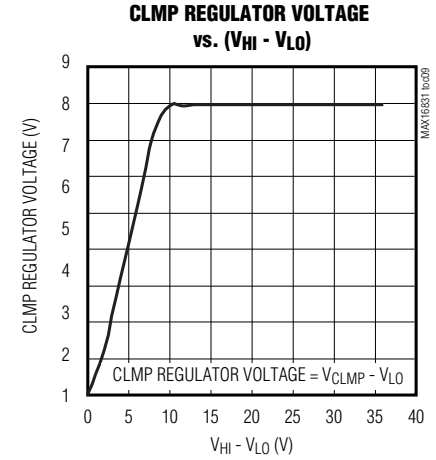
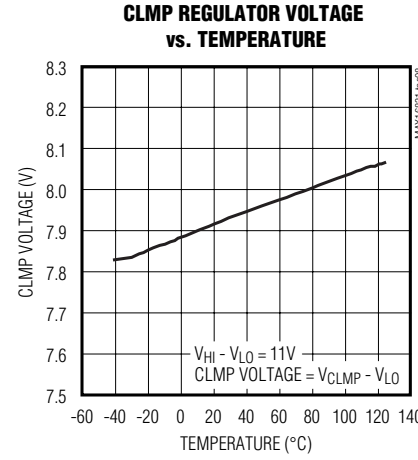
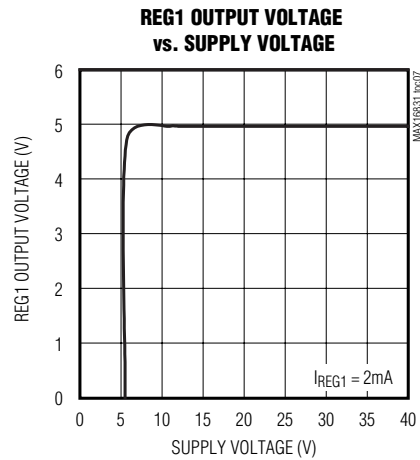
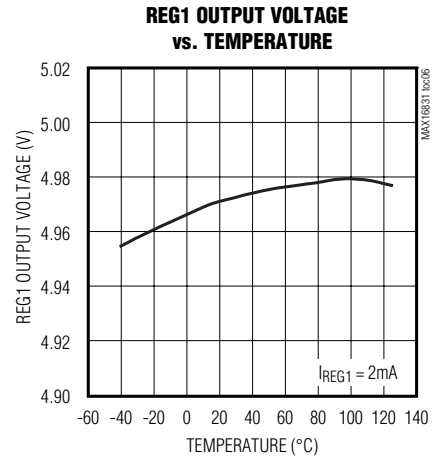
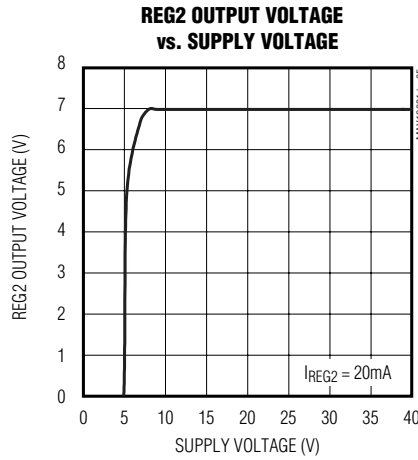
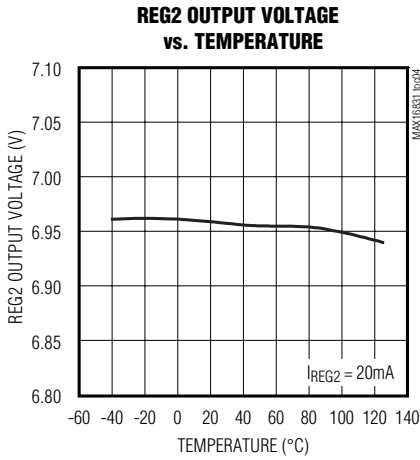

# High-Voltage, High-Power LED Driver with Analog and PWM Dimming Control

MAX16831

## Typical Operating Characteristics (continued)

( $V_{CC} = V_{UVEN} = 14V$ ,  $C_{REG1} = 1\mu F$ ,  $C_{REG2} = 10\mu F$ ,  $C_{CLMP} = 0.1\mu F$ ,  $R_T = 25k\Omega$ ,  $R_{CS} = 0.1\Omega$ ,  $T_A = +25^\circ C$ , unless otherwise noted.)

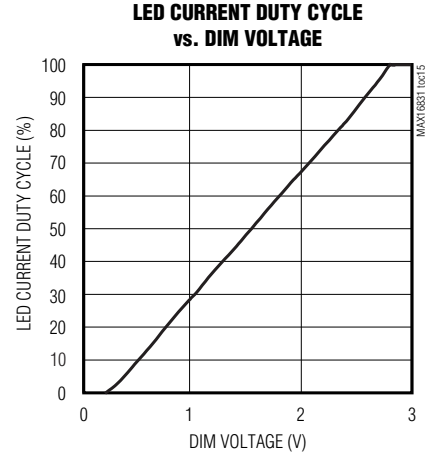
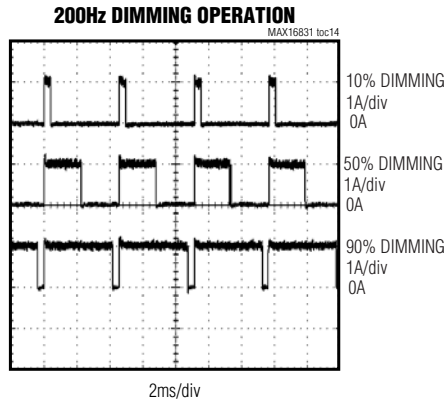
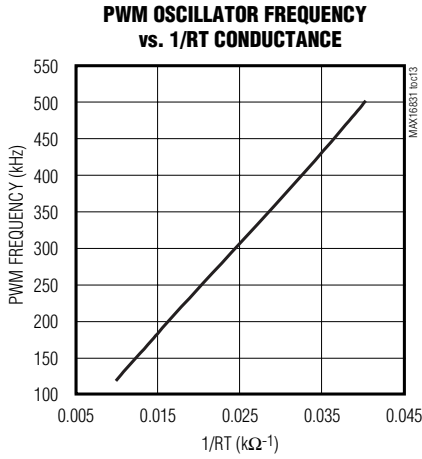

**DRIVER (DRV) RISE TIME**

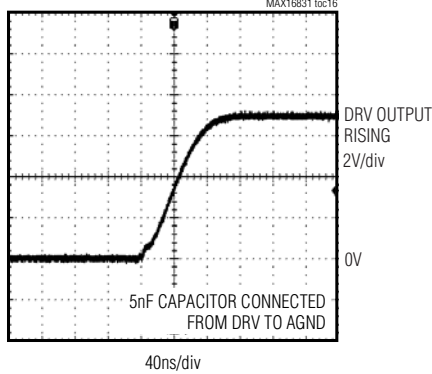

**DRIVER (DRV) FALL TIME**

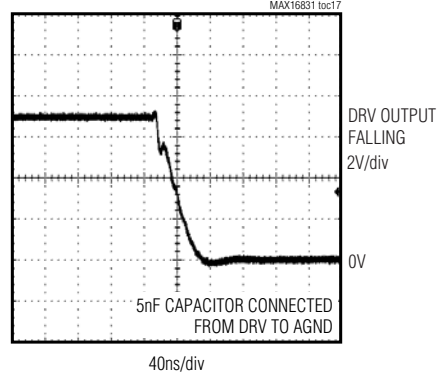

**DGT RISE TIME**

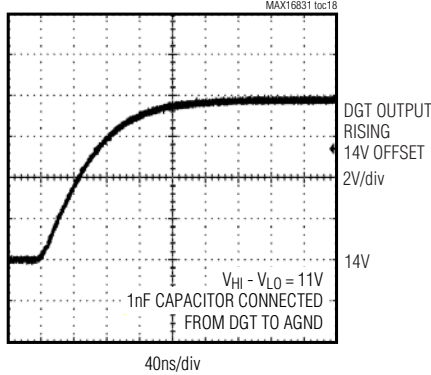

**DGT FALL TIME**

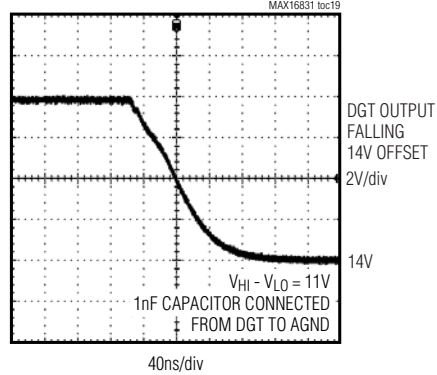

# High-Voltage, High-Power LED Driver with Analog and PWM Dimming Control

## Pin Description

PIN	NAME	FUNCTION
1, 24	N.C.	No Connection. Not internally connected.
2	UVEN	Undervoltage Lockout (UVLO) Threshold/Enable Input. UVEN is a dual-function adjustable UVLO threshold input with an enable feature. Connect UVEN to $V_{CC}$ through a resistive voltage-divider to program the UVLO threshold. Connect UVEN directly to $V_{CC}$ to use the 6.0V (max) default UVLO threshold. Apply a voltage greater than 1.244V to UVEN to enable the device.
3	REG1	5V Regulator Output. REG1 is an internal low-dropout voltage regulator that generates a 5V ( $V_{CC} > 6V$ ) output voltage and supplies power to internal circuitry. Bypass REG1 to AGND through a 1 $\mu$ F ceramic capacitor.
4	AGND	Analog Ground
5	REF	Accurate 3V Buffered Reference Output. Connect REF to DIM through a resistive voltage-divider to apply a DC voltage for analog-controlled dimming functionality. Leave REF unconnected if unused.
6	DIM	Dimming Control Input. Connect DIM to an external PWM signal for PWM dimming. For analog-controlled dimming, connect DIM to REF through a resistive voltage-divider. The dimming frequency is 200Hz under these conditions. Connect DIM to AGND to turn off the LEDs.
7	RTSYNC	SYNC Input/Output. The PWM clock is generated by the RTSYNC oscillator. Connect an external resistor to RTSYNC to select a clock switching frequency from 125kHz to 600kHz or connect RTSYNC to an external clock to synchronize the MAX16831 with a master clock signal.
8	CLKOUT	Clock Output. CLKOUT buffers the oscillator/clock. Connect CLKOUT to the SYNC input of another device to operate the MAX16831 in a multichannel configuration. CLKOUT is a logic output.
9, 10, 11	I.C.	Internally Connected. Must be connected to AGND.
12	COMP	Error-Amplifier Output. Connect the compensation network from COMP to FB for stable closed-loop control. Use low-leakage ceramic capacitors in the feedback network.
13	CS	Current-Sense Amplifier Output. The current-sense amplifier (CSA) senses the differential voltage across the load sense resistor, $R_{CS}$ , and generates a voltage, $V_{CS}$ , at CS proportional to the LED current. Connect the proper compensation resistor from CS to FB.
14	FB	Error-Amplifier Inverting Input
15	OV	Overvoltage Protection Input. Connect OV to HI through a resistive voltage-divider to set the overvoltage limit for the load. When the voltage at OV exceeds the 1.235V (typ) threshold, an overvoltage fault is generated and the switching MOSFET turns off. The MOSFET is turned on again when the voltage at OV drops below 1.17V (typ).
16, 17	SGND	Switching Ground. SGND is the ground for non-analog and high-current gate driver circuitry.
18	DRV	Gate Driver Output. Connect DRV to the gate of an external n-channel MOSFET for switching.
19	DRI	Gate Driver Supply Input. Connect DRI to REG2 to power the primary switching MOSFET driver. Bypass DRI to AGND through a 10 $\mu$ F ceramic capacitor.
20	SNS+	Positive Peak Current-Sense Input. Connect SNS+ to the positive side of the switch current-sense resistor, $R_{SENSE}$ .
21	SNS-	Negative Peak Current-Sense Input. Connect SNS- to the negative side of the switch current-sense resistor, $R_{SENSE}$ .



# High-Voltage, High-Power LED Driver with Analog and PWM Dimming Control

## Pin Description (continued)

MAX16831

PIN	NAME	FUNCTION
22	QGND	Analog Ground. Ensure a low-impedance connection between QGND and AGND.
23	DGT	Dimming Gate Driver Output. Connect DGT to the gate of an external n-channel MOSFET for dimming. DGT is powered by the internal regulator, CLMP, and is referenced to LO.
25	LO	Low-Voltage Input. LO is the return point for the LED current. When using the MAX16831 in a buck-boost configuration, connect LO to V <sub>CC</sub> . When using the device in a boost configuration only, connect LO to SGND. Connect LO to the junction of the inductor and LED current-sense resistor, R <sub>CS</sub> , when using a buck configuration.
26	CS+	Noninverting Current-Sense Amplifier Input. Connect CS+ to the positive side of an external sense resistor, R <sub>CS</sub> , connected in series with the load (LEDs).
27	CS-	Inverting Current-Sense Amplifier Input. Connect CS- to the negative side of an external sense resistor, R <sub>CS</sub> , connected in series with the load (LEDs).
28	CLMP	Internal CLMP Regulator Output. CLMP supplies an 8V (typ) output when V <sub>HI</sub> ≥ 9V. If V <sub>HI</sub> is lower than 9V, V <sub>CLMP</sub> is one diode drop below V <sub>HI</sub> . The CLMP regulator powers the current-sense amplifier and provides the high reference for the dimming driver. V <sub>CLMP</sub> must be at least 2.5V higher than V <sub>LO</sub> to enable the current-sense amplifier and dimming MOSFET driver. Bypass CLMP to LO with a 0.1μF ceramic capacitor.
29	HI	High-Voltage Input. HI is referred to LO. HI supplies power to the current-sense amplifier and dimming MOSFET gate driver through the CLMP regulator.
30	REG2	Internal Regulator Output. REG2 is an internal voltage regulator that generates a 7V output and supplies power to internal circuitry. Connect REG2 to DRI to power the switching MOSFET driver during normal operation. Bypass REG2 to AGND with a 10μF ceramic capacitor.
31	V <sub>CC</sub>	Supply Voltage Input
32	I.C.	Internally Connected. Must be connected directly to QGND.
—	EP	Exposed Pad. Connect EP to AGND. EP also functions as a heatsink to maximize thermal dissipation. Do not use as a ground connection.

## Detailed Description

The MAX16831 is a current-mode PWM LED driver used for driving HBLEDs. By using two current regulation loops, 5% output current accuracy is achieved. One current regulation loop controls the external switching MOSFET peak current through a sense resistor, R<sub>SENSE</sub>, from SNS+ to SNS-, while the other current regulation loop controls the average LED string current through the sense resistor R<sub>CS</sub> in series with the LEDs. The wide operating supply range of (6.0V/5.5V ON/OFF) up to 76V makes the MAX16831 ideal in automotive applications.

The MAX16831 features a programmable undervoltage lockout (UVEN) that ensures predictable operation during brownout conditions. The input UVEN circuit monitors the supply voltage, V<sub>CC</sub>, and turns the driver off when V<sub>CC</sub> drops below the UVLO threshold. Connect UVEN to V<sub>CC</sub> to use the 5.7V (typ) default UVLO thresh-

old. The MAX16831 includes a cycle-by-cycle current limit that turns off the gate drive to the external switching MOSFET (Q<sub>S</sub>) during an overcurrent condition. The MAX16831 features a programmable oscillator that simplifies and optimizes the design of external magnetics.

The MAX16831 includes three internal voltage regulators, REG1, REG2, and CLMP, and a 3V buffered reference output, REF. Connect REG2 to the driver supply, DRI, to power the switching MOSFET driver.

The MAX16831 is capable of synchronizing with an external clock or operating in stand-alone mode. A single resistor, R<sub>T</sub>, can be used to adjust the switching frequency from 125kHz to 600kHz for stand-alone operation. To synchronize the device with an external clock, apply a clock signal directly to the RTSYNC input. A buffered clock output, CLKOUT, is available to configure the MAX16831 in multichannel applications.

# High-Voltage, High-Power LED Driver with Analog and PWM Dimming Control

The MAX16831 features a differential high-side level shifter to drive an external n-channel MOSFET for dimming. Wide contrast “pulsed” dimming (1000:1) is possible by applying either a low-frequency PWM input signal or a DC voltage to the dimming input (DIM).

Protection features include peak current limiting, HICCUP mode current limiting, output overvoltage protection, short-circuit protection, and thermal shutdown. The HICCUP current-limit circuitry reduces the power delivered to the load during severe fault conditions. Nonlatching overvoltage protection limits the voltage on the external switching MOSFET (Q<sub>S</sub>) under open-circuit conditions in the LED string. During continuous operation at high input voltages, the power dissipation of the MAX16831 could exceed the maximum rating and an internal thermal shutdown circuitry safely turns off the MAX16831 when the device junction temperature exceeds +165°C. When the junction temperature drops below the hysteresis temperature, the MAX16831 automatically re-initiates startup.

## Undervoltage Lockout/Enable

The MAX16831 features a dual-purpose adjustable UVLO input and enable function. Connect UVEN to V<sub>CC</sub> through a resistive voltage-divider to set the undervoltage lockout (UVLO) threshold. The MAX16831 is enabled when the UVEN exceeds the 1.244V (typ) threshold. Drive UVEN to ground to disable the output.

## Setting the UVLO Threshold

The MAX16831 features a programmable UVLO threshold. Connect UVEN directly to V<sub>CC</sub> to select the default 6.0V (max) UVLO threshold. Connect UVEN to V<sub>CC</sub> through a resistive voltage-divider to select a UVLO threshold (Figure 1). Calculate resistor values as follows:

$$R_{UV1} = R_{UV2} \times \left( \frac{V_{UVEN}}{V_{UVLO} - V_{UVEN}} \right)$$

where  $R_{UV1} + R_{UV2} \leq 270k\Omega$ ,  $V_{UVEN}$  is the 1.244V (typ) threshold voltage, and  $V_{UVLO}$  is the desired UVLO threshold in volts at V<sub>CC</sub> (Figure 1).

The capacitor, C<sub>UVEN</sub>, is required to prevent chattering at the UVLO threshold due to line impedance drops during power-up and dimming. If the undervoltage setting is very close to the required minimum operating voltage, then there can be jumps in the voltage at V<sub>CC</sub> during dimming, which may cause the MAX16831 to turn on and off when the dimming signal transitions from low to high. The capacitor, C<sub>UVEN</sub>, should be

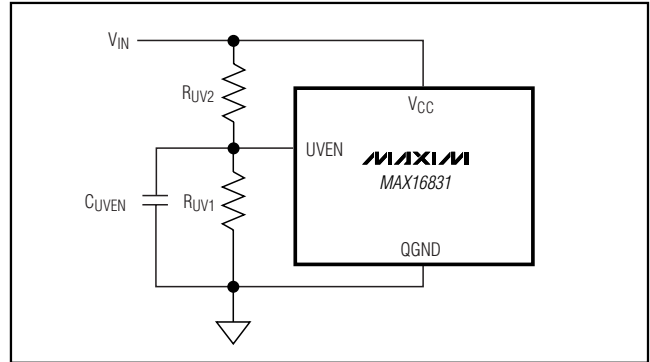

Figure 1. Setting the UVLO Threshold

large enough to limit the ripple on UVEN to less than the 100mV (min) UVEN hysteresis so that the device does not turn off under these circumstances.

## Soft-Start

The MAX16831 includes a factory-set 4ms (typ) soft-start delay that allows the load current to ramp up in a controlled manner, minimizing output overshoot. Soft-start begins once the device is enabled and V<sub>CC</sub> exceeds the UVLO threshold. Soft-start circuitry slowly increases the internal soft-start voltage, V<sub>SS</sub>, resulting in a controlled rise of the load current. Signals applied to DIM are ignored until the soft-start duration is complete and a successive delay of 200μs has elapsed.

## Internal Regulators

The MAX16831 includes a fixed 5V voltage regulator REG1, a 7V voltage regulator REG2, and an internal 8V regulator CLMP. REG1 and REG2 power up when V<sub>CC</sub> exceeds the UVLO threshold. REG1 supplies power to internal circuitry and remains on during PWM dimming. It is capable of driving external loads up to 2mA.

REG2 is capable of delivering up to 20mA of current. Connect REG2 to DRI to generate the supply voltage for the primary switching MOSFET driver, DRV.

CLMP is powered by HI and supplies power to the current-sense amplifier (CSA). CSA is enabled when V<sub>CLMP</sub> goes 2.5V above V<sub>LO</sub> and is disabled when (V<sub>CLMP</sub> - V<sub>LO</sub>) falls below 2.28V. The CLMP regulator also provides power to the dimming MOSFET control circuitry. CLMP is the output of the CLMP regulator. Do not use CLMP to power external circuitry. Bypass CLMP to LO with a 0.1μF ceramic capacitor. A larger capacitor will result in overshoots of the load current.

# High-Voltage, High-Power LED Driver with Analog and PWM Dimming Control

MAX16831

## Reference Voltage Output

The MAX16831 includes a 5% accurate 3V (typ) buffered reference output, REF. REF is a push-pull output capable of sourcing/sinking 100µA of current and can drive a maximum load capacitance of 100pF. Connect REF to DIM through a resistive voltage-divider to supply an analog signal for dimming. See the *Dimming Input (DIM)* section.

## Dimming MOSFET Driver (DDR)

The MAX16831 requires an external n-channel MOSFET for PWM dimming. Connect the MOSFET to the output of the DDR dimming driver, DGT, for normal operation.  $V_{DGT}$  swings between  $V_{LO}$  and  $V_{CLMP}$ . The DDR dimming driver is capable of sinking or sourcing up to 20mA of current. The average current required to drive the dimming MOSFET ( $I_{DRIVE\_DIM}$ ) depends on the MOSFET's total gate charge ( $Q_{G\_DIM}$ ) and the dimming frequency of the converter,  $f_{DIM}$ . Use the following equation to calculate the average gate drive current for the n-channel dimming FET.

$$I_{DRIVE\_DIM} = Q_{G\_DIM} \times f_{DIM}$$

## n-Channel MOSFET Switch Driver (DRV)

The MAX16831 drives an external n-channel MOSFET. Use an external supply or connect REG2 to DRI to power the MOSFET driver. The driver output,  $V_{DRV}$ , swings between ground and  $V_{DRI}$ . Ensure that  $V_{DRI}$  remains below the absolute maximum  $V_{GS}$  rating of the external MOSFET. DRV is capable of sinking 2.5A or sourcing 1.4A of peak current, allowing the MAX16831 to switch MOSFETs in high-power applications. The average current sourced to drive the external MOSFET depends on the total gate charge ( $Q_G$ ) and operating frequency of the converter,  $f_{sw}$ . The power dissipation in the MAX16831 is a function of the average output drive current ( $I_{DRIVE}$ ). Use the following equations to calculate the power dissipation in the gate driver section of the MAX16831 due to  $I_{DRIVE}$ :

$$I_{DRIVE} = Q_G \times f_{sw}$$

$$P_D = (I_{DRIVE} + I_{CC}) \times V_{DRI}$$

where  $V_{DRI}$  is the supply voltage to the gate driver and  $I_{CC}$  is the operating supply current.  $I_{DRIVE}$  should not exceed 20mA.

## Dimming Input (DIM)

The dimming input, DIM, functions with either analog or PWM control signals. Once the internal pulse detector detects three successive edges of a PWM signal with a frequency between 80Hz and 2kHz, the MAX16831 synchronizes to the external signal and pulse-width-modulates the LED current at the external DIM input frequency with the same duty cycle as the DIM input. If an analog

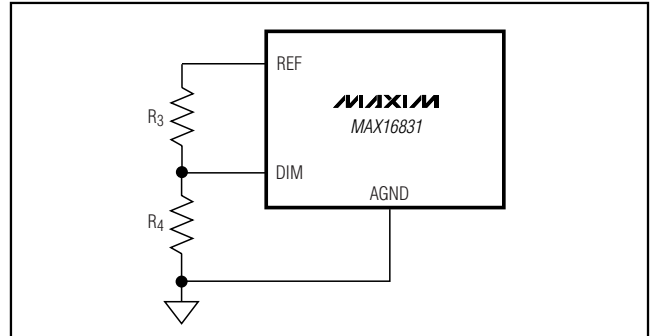

Figure 2. Creating a DIM Input Signal from REF

control signal is applied to DIM, the MAX16831 compares the DC input to an internally generated 200Hz ramp to pulse-width-modulate the LED current ( $f_{DIM} = 200\text{Hz}$ ). The output current duty cycle is linearly adjustable from 0 to 100% ( $0.2\text{V} < V_{DIM} < 2.8\text{V}$ ).

Use the following formula to calculate the voltage,  $V_{DIM}$ , necessary for a given output-current duty cycle, D:

$$V_{DIM} = (D \times 2.6) + 0.2\text{V}$$

where  $V_{DIM}$  is the voltage applied to DIM in volts.

Connect DIM to REF through a resistive voltage-divider to apply a DC DIM control signal (Figure 2). Use the required dimming input voltage,  $V_{DIM}$ , calculated above and select appropriate resistor values using the following equation:

$$R_4 = R_3 \times V_{DIM} / (V_{REF} - V_{DIM})$$

where  $V_{REF}$  is the 3V reference output voltage and  $30\text{k}\Omega \leq R_3 + R_4 \leq 150\text{k}\Omega$ .

For proper operation at startup or after toggling ENABLE, the controller needs three clock edges or an analog voltage greater than 0.3V on the DIM input.

## Oscillator, Clock, and Synchronization

The MAX16831 is capable of stand-alone operation or synchronizing to an external clock, and driving external devices in SYNC mode. For stand-alone operation, program the switching frequency by connecting a single external resistor,  $R_T$ , between RTSYNC and ground. Select the switching frequency,  $f_{sw}$ , from 125kHz to 600kHz and calculate  $R_T$  using the following formula:

$$R_T = \frac{500\text{kHz}}{f_{sw}} \times 25\text{k}\Omega$$

where the switching frequency is in kHz and  $R_T$  is in  $\text{k}\Omega$ .

The MAX16831 is also capable of synchronizing to an external clock signal ranging from 125kHz to 600kHz.

# High-Voltage, High-Power LED Driver with Analog and PWM Dimming Control

Connect the clock signal to the RTSYNC input. The MAX16831 synchronizes to the external clock signal after the detection of five successive clock edges at RTSYNC.

A buffered clock output, CLKOUT, is capable of driving the RTSYNC input of an external PWM controller for multichannel applications. CLKOUT is capable of driving capacitive loads up to 500pF.

## Multichannel Configuration

The MAX16831 is capable of multichannel operation. Connect CLKOUT to the SYNC input of an external device to use the MAX16831 as a master clock signal. Connect an external clock signal to RTSYNC to configure the MAX16831 as a slave. To setup two or more MAX16831 devices in a daisy-chain/peer-to-peer configuration, drive the RTSYNC input of one MAX16831 with the CLKOUT buffer of another (Figure 3).

## ILIM and HICCUP Comparator

RSENSE sets the peak current through the inductor for switching. The differential voltage across RSENSE is compared to the 200mV voltage trip limit of the current-limit comparator, ILIM. Set the current limit 20% higher than the peak switch current at the rated output power and minimum voltage. Use the following equation to calculate RSENSE:

$$R_{SENSE} = V_{SENSE} / (1.2 \times I_{PEAK})$$

where  $V_{SENSE}$  is the 200mV differential voltage between SNS+ and SNS- and  $I_{PEAK}$  is the peak inductor current at full load and minimum input voltage.

When the voltage drop across RSENSE exceeds the ILIM threshold, the MOSFET driver (DRV) terminates the on-cycle and turns the switch off, reducing the current through the inductor. The FET is turned back on at the beginning of the next switching cycle.

When the voltage across RSENSE exceeds the 300mV (typ) HICCUP threshold, the HIC comparator terminates the on-cycle of the device, turning the switching MOSFET off. Following a startup delay of 4ms (typ), the MAX16831 re-initiates soft-start. The device will continue to operate in HICCUP mode until the overcurrent condition is removed.

A built-in 40ns leading-edge blanking circuit of the current-sense signal prevents these comparators from prematurely terminating the on-cycle of the external switching MOSFET ( $Q_S$ ). In some cases, this blanking time may not be adequate and an additional RC filter may be required to prevent spurious turn-off.

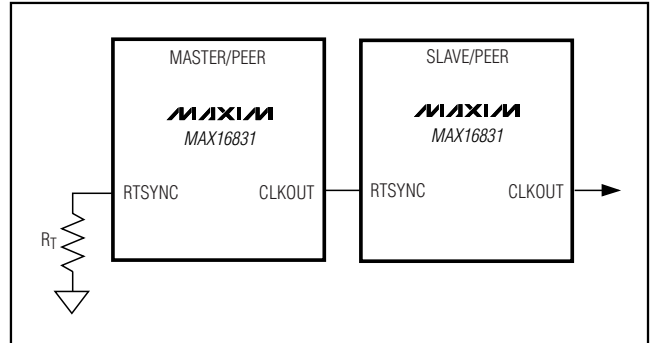

Figure 3. Master-Slave/Peer-Peer Clock Configuration

## Load Current Sense

The load-sense resistor,  $R_{CS}$ , monitors the current through the LEDs. The internal floating current-sense amplifier, CSA, measures the differential voltage across  $R_{CS}$ , and generates a voltage proportional to the LED current through  $R_{CS}$  at CS. This voltage on CS is referred to AGND. The closed loop regulates the LED current to a value,  $I_{LED}$ , given by the following equation:

$$I_{LED} = 0.107V / R_{CS}$$

## Slope Compensation

The MAX16831 uses an internal ramp generator for slope compensation. The internal ramp signal is reset to zero at the beginning of each cycle and has a peak-to-peak voltage of 120mV per switching cycle. Use an external resistor,  $R_T$ , to set the switching frequency,  $f_{SW}$ , and calculate the slope of the compensating ramp,  $m_{SLOPE}$ , using the following equation:

$$m_{SLOPE} = 120 \times f_{SW} \text{ [mV/s]}$$

where  $f_{SW}$  is the switching frequency in Hz. When the MAX16831 is synchronized to an external clock, the slope compensation ramp has a slope of 15mV/ $\mu$ s.

## Internal Voltage-Error Amplifier (EAMP)

The MAX16831 includes a built-in voltage amplifier, with tri-state output, which can be used to close the feedback loop. The buffered output current-sense signal appears at CS, which is connected to the inverting input, FB, of the error amplifier through resistor  $R_1$ . The noninverting input is connected to an internally trimmed current reference.

The output of the error amplifier is controlled by the signal applied to DIM. When DIM is high, the output of the amplifier is connected to COMP. The amplifier output is open when DIM is low. This enables the integrating

# High-Voltage, High-Power LED Driver with Analog and PWM Dimming Control

MAX16831

capacitor to hold the charge when the DIM signal has turned off the gate drive. When DIM is high again, the voltage on the compensation capacitors, C1 and C2, will force the converter into steady-state instantaneously.

## PWM Dimming

PWM dimming is achieved by driving DIM with either a PWM signal or a DC signal. The PWM signal is internally connected to the error amplifier, the dimming MOSFET gate driver, and the switching MOSFET gate driver. When the DIM signal is high, the dimming MOSFET and the switching MOSFET drivers are enabled and the output of the voltage-error amplifier is connected to the external compensation network. Also, the buffered current-sense signal is connected to CS. Preventing discharge of the compensation capacitor when the DIM signal is low will allow the control loop to return the LED current to its original value almost instantaneously.

When the DIM signal goes low, the output of the error amplifier is disconnected from the compensation network and the voltage of compensation capacitors, C1 and C2 is preserved. Choose low-leakage capacitors for C1 and C2. The drivers for the external dimming and switching MOSFETs are disabled, and the converter stops switching. The inductor energy is now transferred to the output capacitors.

When the DIM signal goes high and the gate drivers are enabled, the additional voltage on the output capacitor may cause a current spike on the LED string. A larger output capacitor will result in a smaller current spike. The MAX16831 thus achieves fast PWM dimming response.

## Fault Protection

The MAX16831 features built-in overvoltage protection, overcurrent protection, HICCUP mode current-limit protection, and thermal shutdown. Overvoltage protection is achieved by connecting OV to HI through a resistive voltage-divider. HICCUP mode limits the power dissipation in the external MOSFETs during severe fault conditions. Internal thermal shutdown protection safely turns off the converter when the junction temperature exceeds +165°C.

## Overvoltage Protection

The overvoltage protection (OVP) comparator compares the voltage at OV with a 1.235V (typ) internal reference. When the voltage at OV exceeds the internal reference, the OVP comparator terminates PWM switching and no further energy is transferred to the

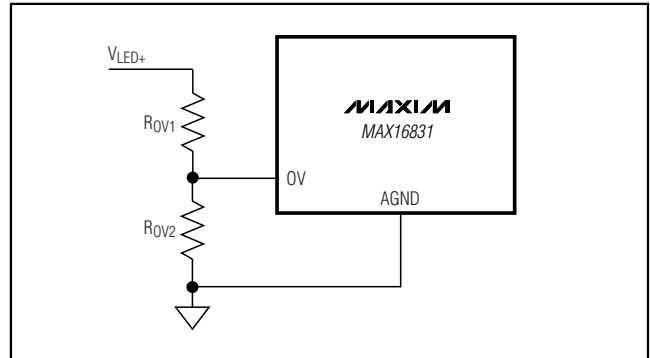

Figure 4. Setting the Overvoltage Threshold

load. The MAX16831 re-initiates soft-start once the overvoltage condition is removed. Connect OV to HI through a resistive voltage-divider to set the overvoltage threshold at the output.

## Setting the Overvoltage Threshold

Connect OV to HI or to the high-side of the LEDs through a resistive voltage-divider to set the overvoltage threshold at the output (Figure 4). The overvoltage protection (OVP) comparator compares the voltage at OV with a 1.235V (typ) internal reference. Use the following equation to calculate resistor values:

$$R_{OV1} = R_{OV2} \times \left( \frac{V_{OV\_LIM} - V_{OV}}{V_{OV}} \right)$$

where  $V_{OV}$  is the 1.235V OV threshold. Choose  $R_{OV1}$  and  $R_{OV2}$  to be reasonably high-value resistors to prevent discharge of filter capacitors. This will prevent unnecessary undervoltage and overvoltage conditions during dimming.

## Load-Dump Protection

The MAX16831 features load-dump protection up to 80V. LED drivers using the MAX16831 can sustain single fault load dump events. Repeated load dump events within very short time intervals can cause damage to the dimming MOSFET due to excess power dissipation.

## Thermal Shutdown

The MAX16831 contains an internal temperature sensor that turns off all outputs when the die temperature exceeds +165°C. Outputs are enabled again when the die temperature drops below +145°C.

# High-Voltage, High-Power LED Driver with Analog and PWM Dimming Control

## Applications Information

### Inductor Selection

The minimum required inductance is a function of operating frequency, input-to-output voltage differential, and the peak-to-peak inductor current ( $\Delta I_L$ ). Higher  $\Delta I_L$  allows for a lower inductor value while a lower  $\Delta I_L$  requires a higher inductor value. A lower inductor value minimizes size and cost, improves large-signal transient response but reduces efficiency due to higher peak currents and higher peak-to-peak output ripple voltage for the same output capacitance. On the other hand, higher inductance increases efficiency by reducing the ripple current,  $\Delta I_L$ . However, resistive losses due to extra turns can exceed the benefit gained from lower ripple current levels, especially when the inductance is increased without also allowing for larger inductor dimensions. A good compromise is to choose  $\Delta I_L$  equal to 30% of the full load current. The inductor saturating current is also important to avoid runaway current during the output overload and continuous short circuit. Select the  $I_{SAT}$  to be higher than the maximum peak current limit.

Buck configuration: In a buck configuration, the average inductor current does not vary with the input. The worst-case peak current occurs at a high input voltage. In this case, the inductance  $L$  for continuous conduction mode is given by:

$$L = \frac{V_{OUT} \times (V_{INMAX} - V_{OUT})}{V_{INMAX} \times f_{SW} \times \Delta I_L}$$

where  $V_{INMAX}$  is the maximum input voltage,  $f_{SW}$  is the switching frequency, and  $V_{OUT}$  is the output voltage.

Boost configuration: In the boost converter, the average inductor current varies with line and the maximum average current occurs at low line. For the boost converter, the average inductor current is equal to the input current. In this case, the inductance  $L$  is calculated as:

$$L = \frac{V_{INMIN} \times (V_{OUT} - V_{INMIN})}{V_{OUT} \times f_{SW} \times \Delta I_L}$$

where  $V_{INMIN}$  is the minimum input voltage,  $V_{OUT}$  is the output voltage, and  $f_{SW}$  is the switching frequency.

Buck-boost configuration: In a buck-boost converter, the average inductor current is equal to the sum of the input current and the load current. In this case, the inductance  $L$  is:

$$L = \frac{V_{OUT} \times V_{INMIN}}{(V_{OUT} + V_{INMIN}) \times f_{SW} \times \Delta I_L}$$

where  $V_{INMIN}$  is the minimum input voltage,  $V_{OUT}$  is the output voltage, and  $f_{SW}$  is the switching frequency.

### Output Capacitor

The function of the output capacitor is to reduce the output ripple to acceptable levels. The ESR, ESL, and the bulk capacitance of the output capacitor contribute to the output ripple. In most of the applications, the output ESR and ESL effects can be dramatically reduced by using low-ESR ceramic capacitors. To reduce the ESL effects, connect multiple ceramic capacitors in parallel to achieve the required bulk capacitance.

In a buck configuration, the output capacitance,  $C_F$ , is calculated using the following equation:

$$C_F \geq \frac{(V_{INMAX} - V_{OUT}) \times V_{OUT}}{\Delta V_R \times 2 \times L \times V_{INMAX} \times f_{SW}^2}$$

where  $\Delta V_R$  is the maximum allowable output ripple.

In a boost configuration, the output capacitance,  $C_F$ , is calculated as:

$$C_F \geq \frac{(V_{OUT} - V_{INMIN}) \times 2 \times I_{OUT}}{\Delta V_R \times V_{OUT} \times f_{SW}}$$

where  $I_{OUT}$  is the output current.

In a buck-boost configuration, the output capacitance,  $C_F$ , is calculated as:

$$C_F \geq \frac{2 \times V_{OUT} \times I_{OUT}}{\Delta V_R \times (V_{OUT} + V_{INMIN}) \times f_{SW}}$$

where  $V_{OUT}$  is the voltage across the load and  $I_{OUT}$  is the output current. Connect the output capacitor(s) from the output to ground in a buck-boost configuration (not across the load as for other configurations).

### Input Capacitor

An input capacitor connected between UVEN and ground must be used when configuring the MAX16831 as a buck converter. Use a low-ESR input capacitor that can handle the maximum input RMS ripple current. Calculate the maximum allowable RMS ripple using the following equation:

$$I_{IN(RMS)} = \frac{I_{OUT} \times \sqrt{V_{OUT} \times (V_{INMIN} - V_{OUT})}}{V_{INMIN}}$$

In most of the cases, an additional electrolytic capacitor should be added to prevent input oscillations due to line impedances.

# High-Voltage, High-Power LED Driver with Analog and PWM Dimming Control

When using the MAX16831 in a boost or buck-boost configuration, the input RMS current is low and the input capacitance can be small.

## Operating the MAX16831 Without the Dimming Switch

The MAX16831 can also be used in the absence of the dimming MOSFET. In this case, the PWM dimming performance is compromised but in applications that do not require dimming, the MAX16831 can still be used. A short circuit across the load will cause the MAX16831 to disable the gate drivers and they will remain off until the input power is recycled.

## Switching Power MOSFET Losses

When selecting MOSFETs for switching, consider the total gate charge, power dissipation, the maximum drain-to-source voltage, and package thermal impedance. The product of the MOSFET gate charge and  $R_{DS(ON)}$  is a figure of merit, with a lower number signifying better performance. Select MOSFETs optimized for high-frequency switching applications.

MOSFET losses may be broken into three categories: conduction loss, gate drive loss, and switching loss. The following simplified power loss equation is true for all the different configurations.

$$P_{LOSS} = P_{CONDUCTION} + P_{GATEDRIVE} + P_{SWITCH}$$

## Layout Recommendations

Typically, there are two sources of noise emission in a switching power supply: high di/dt loops and high dv/dt surfaces. For example, traces that carry the drain current often form high di/dt loops. Similarly, the heatsink of the MOSFET connected to the device drain presents a high dv/dt source; therefore, minimize the surface area of the heatsink as much as possible. Keep all PCB traces carrying switching currents as short as possible to minimize current loops. Use ground planes for best results.

Careful PCB layout is critical to achieve low switching losses and clean, stable operation. Use a multilayer board whenever possible for better noise performance and power dissipation. Follow these guidelines for good PCB layout:

- Use a large copper plane under the MAX16831 package. Ensure that all heat-dissipating components have adequate cooling. Connect the exposed pad of the device to the ground plane.

- Isolate the power components and high-current paths from sensitive analog circuitry.
- Keep the high-current paths short, especially at the ground terminals. This practice is essential for stable, jitter-free operation. Keep switching loops short.
- Connect AGND, SGND, and QGND to a ground plane. Ensure a low-impedance connection between all ground points.
- Keep the power traces and load connections short. This practice is essential for high efficiency. Use thick copper PCBs (2oz vs. 1oz) to enhance full-load efficiency.
- Ensure that the feedback connection to FB is short and direct.
- Route high-speed switching nodes away from the sensitive analog areas.
- To prevent discharge of the compensation capacitors, C1 and C2, during the off-time of the dimming cycle, ensure that the PCB area close to these components has extremely low leakage. Discharge of these capacitors due to leakage may result in degraded dimming performance.

## Chip Information

PROCESS: BICMOS

## Pin Configuration

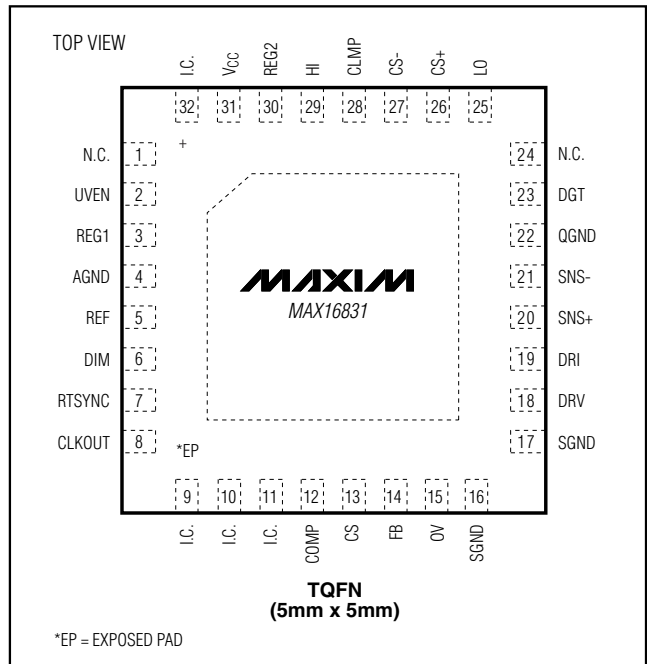

# High-Voltage, High-Power LED Driver with Analog and PWM Dimming Control

## Functional Diagram

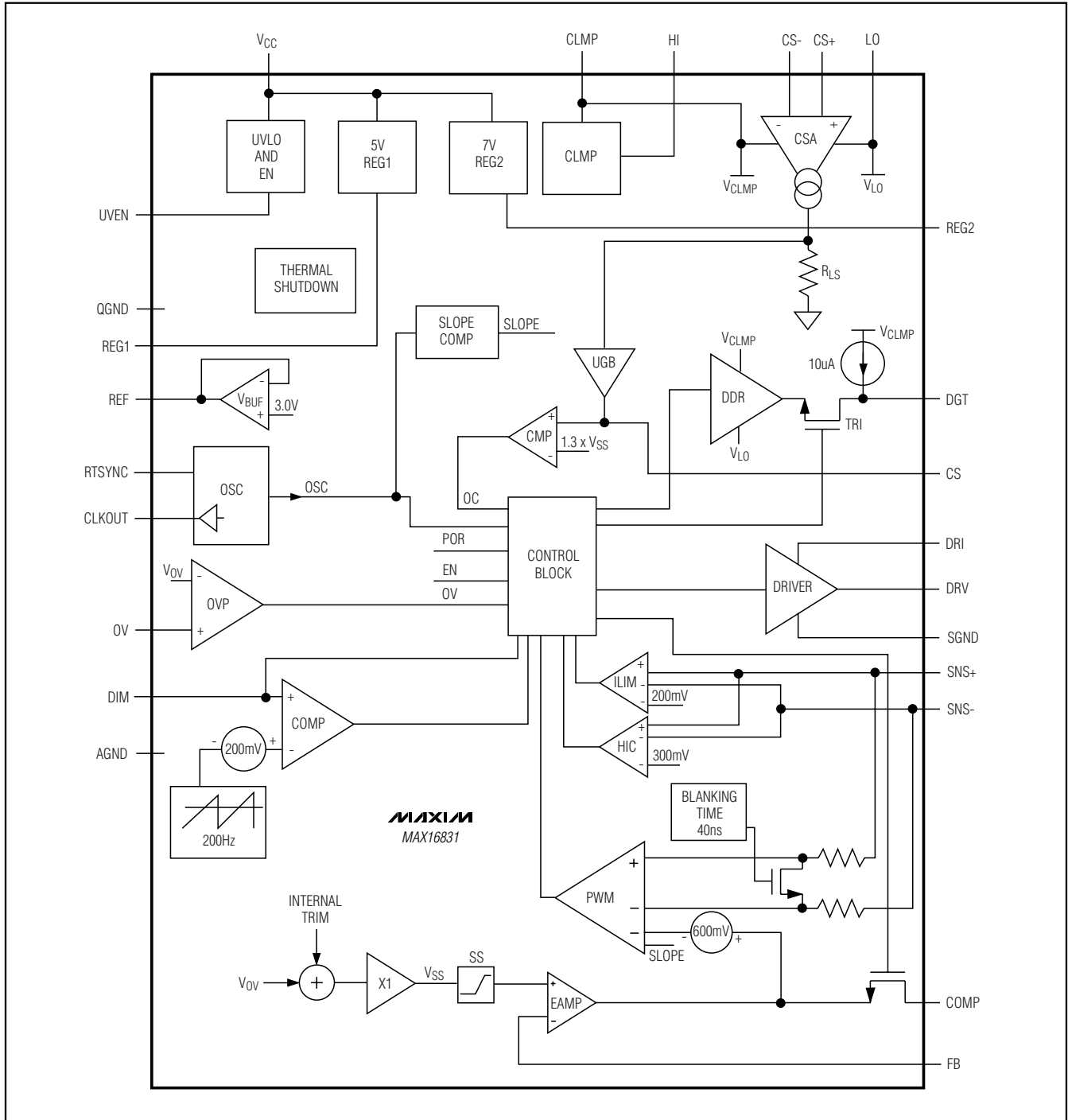



# High-Voltage, High-Power LED Driver with Analog and PWM Dimming Control

## Typical Operating Circuits (continued)

MAX16831

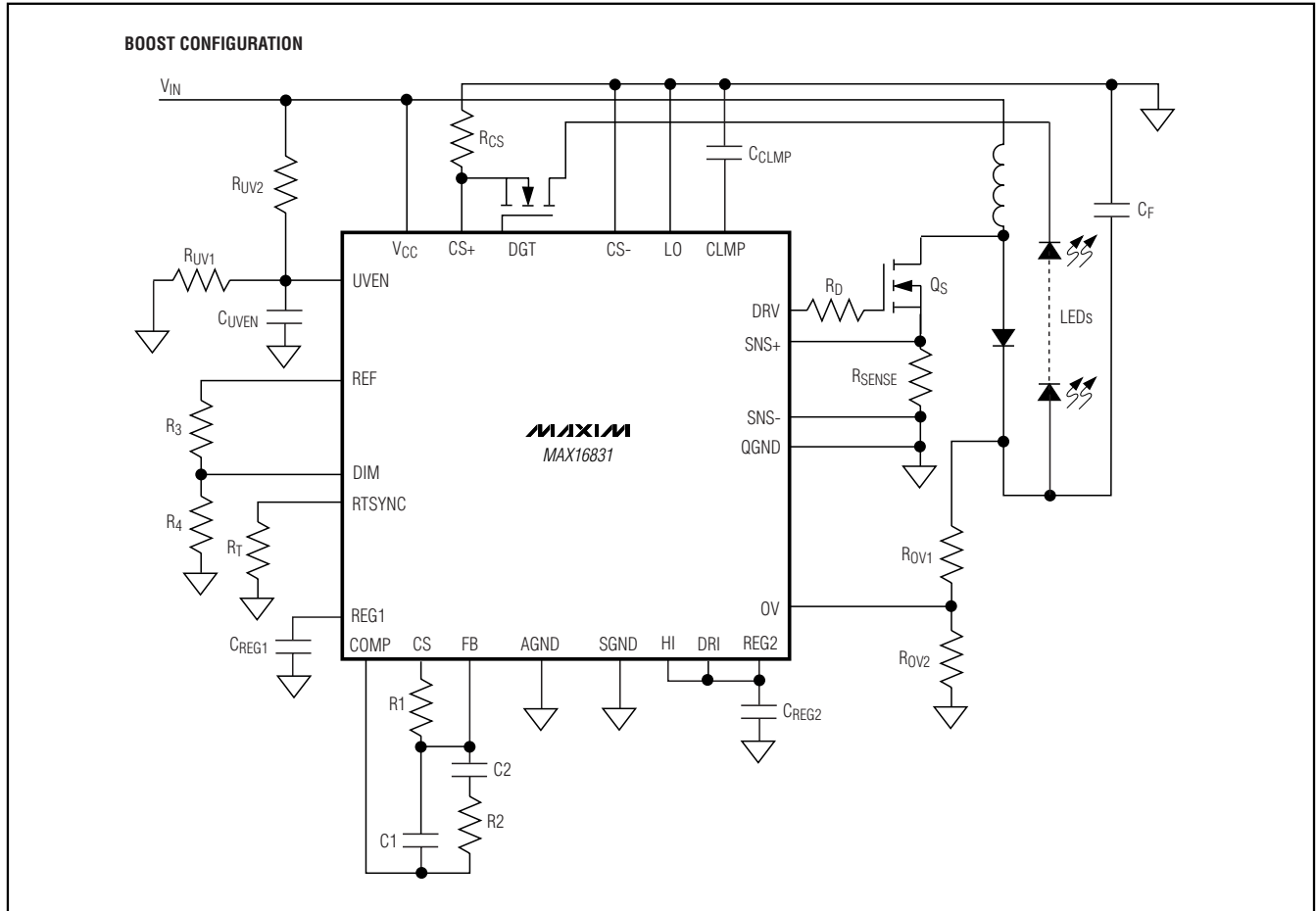

www.DataSheet4U.com

# High-Voltage, High-Power LED Driver with Analog and PWM Dimming Control

## Typical Operating Circuits (continued)

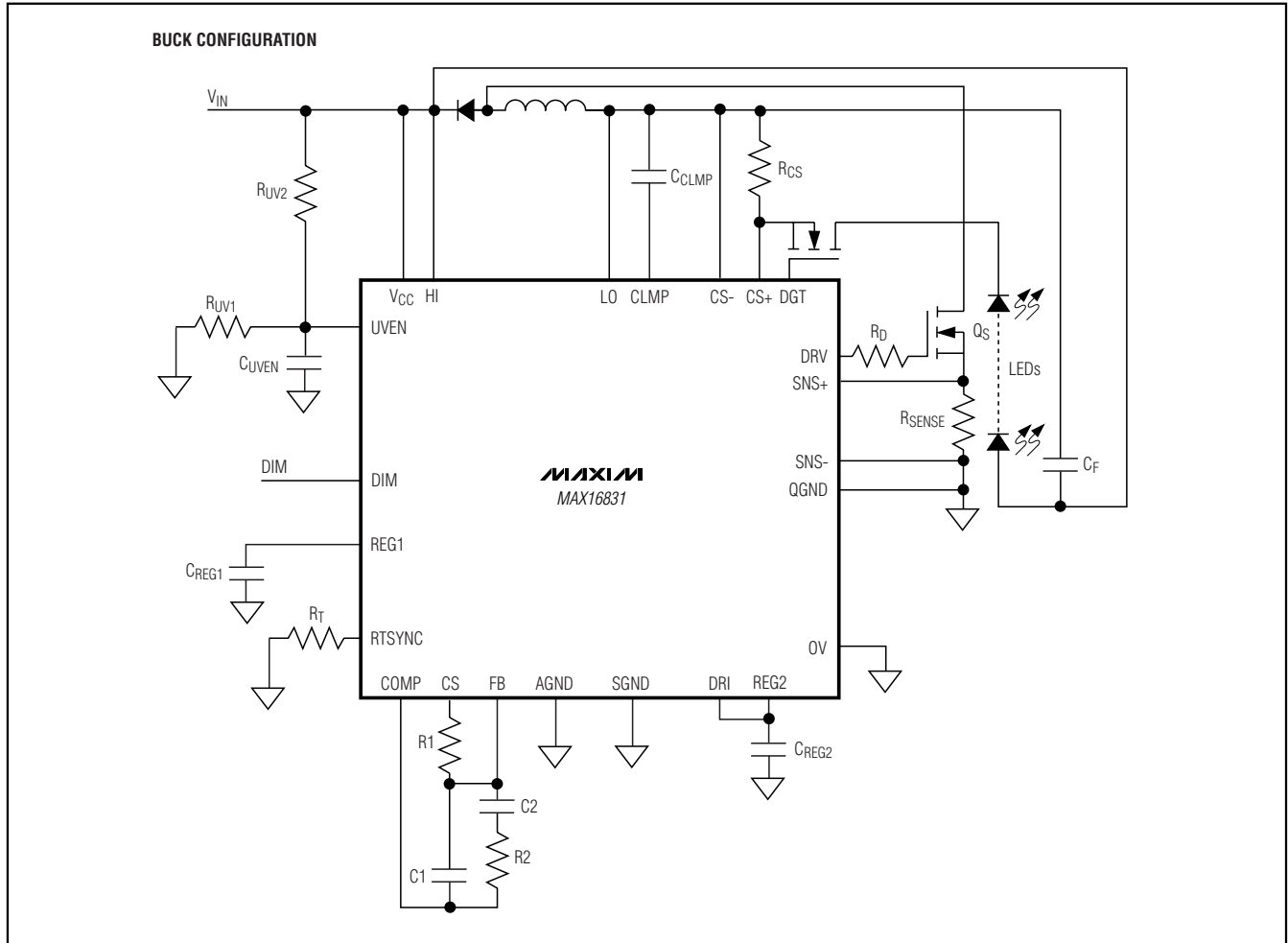

www.DataSheet4U.com

# High-Voltage, High-Power LED Driver with Analog and PWM Dimming Control

## Package Information

(The package drawing(s) in this data sheet may not reflect the most current specifications. For the latest package outline information go to [www.maxim-ic.com/packages](http://www.maxim-ic.com/packages).)

MAX16831

QFN THIN.EPS

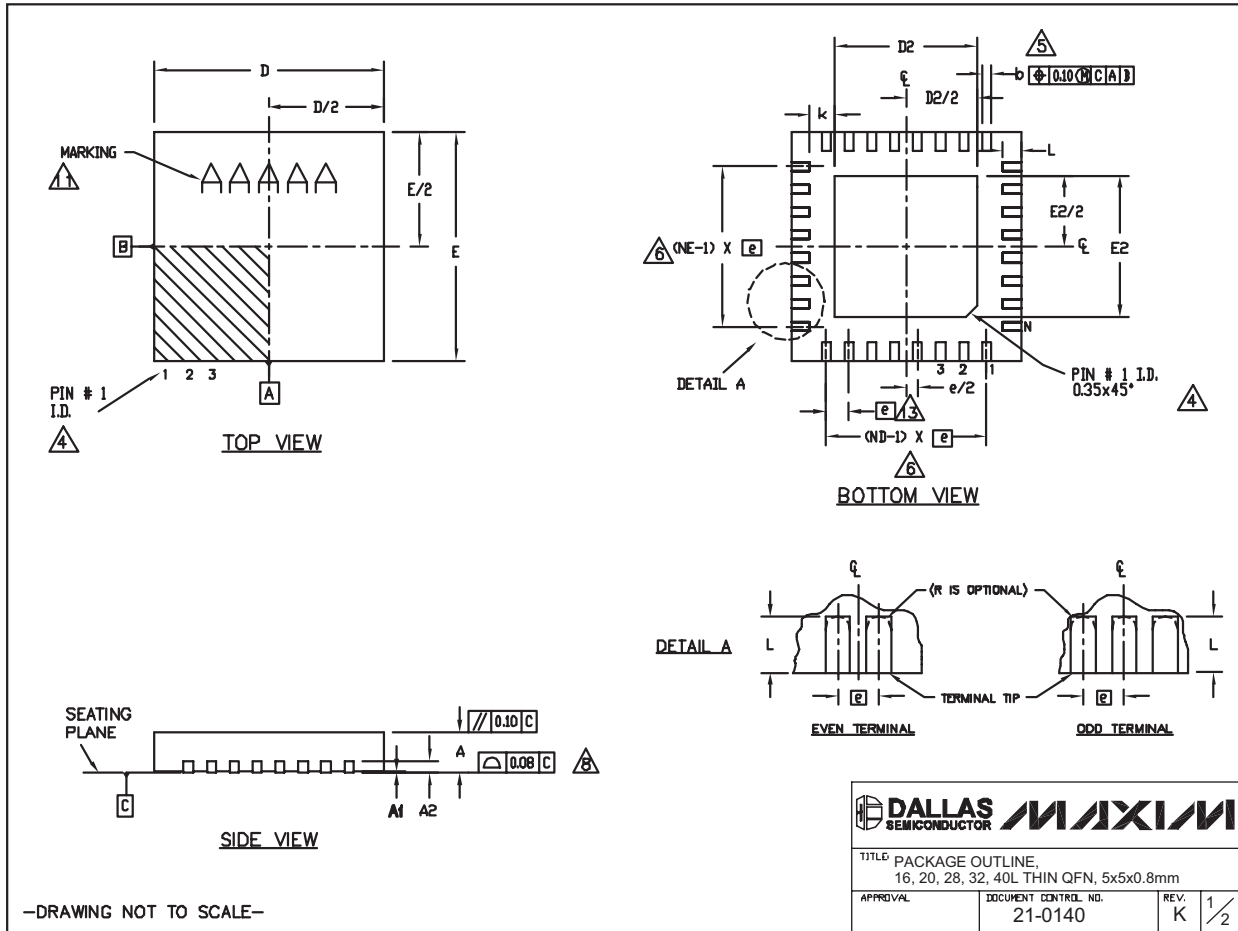

# High-Voltage, High-Power LED Driver with Analog and PWM Dimming Control

## Package Information (continued)

(The package drawing(s) in this data sheet may not reflect the most current specifications. For the latest package outline information go to [www.maxim-ic.com/packages](http://www.maxim-ic.com/packages).)

COMMON DIMENSIONS															
PKG. SYMBOL	16L 5x5			20L 5x5			28L 5x5			32L 5x5			40L 5x5		
	MIN.	NOM.	MAX.	MIN.	NOM.	MAX.	MIN.	NOM.	MAX.	MIN.	NOM.	MAX.	MIN.	NOM.	MAX.
A	0.70	0.75	0.80	0.70	0.75	0.80	0.70	0.75	0.80	0.70	0.75	0.80	0.70	0.75	0.80
A1	0	0.02	0.05	0	0.02	0.05	0	0.02	0.05	0	0.02	0.05	0	0.02	0.05
A2	0.20 REF.			0.20 REF.			0.20 REF.			0.20 REF.			0.20 REF.		
b	0.25	0.30	0.35	0.25	0.30	0.35	0.20	0.25	0.30	0.20	0.25	0.30	0.15	0.20	0.25
D	4.90	5.00	5.10	4.90	5.00	5.10	4.90	5.00	5.10	4.90	5.00	5.10	4.90	5.00	5.10
E	4.90	5.00	5.10	4.90	5.00	5.10	4.90	5.00	5.10	4.90	5.00	5.10	4.90	5.00	5.10
e	0.80 BSC.			0.65 BSC.			0.50 BSC.			0.50 BSC.			0.40 BSC.		
k	0.25	-	-	0.25	-	-	0.25	-	-	0.25	-	-	0.25	-	-
L	0.30	0.40	0.50	0.45	0.55	0.65	0.45	0.55	0.65	0.30	0.40	0.50	0.30	0.40	0.50
N	16			20			28			32			40		
ND	4			5			7			8			10		
NE	4			5			7			8			10		
JEDEC	VHMB			WHHC			WHHD-1			VHHD-2			-----		

EXPOSED PAD VARIATIONS						
PKG. CODES	D2			E2		
	MIN.	NOM.	MAX.	MIN.	NOM.	MAX.
T1655-2	3.00	3.10	3.20	3.00	3.10	3.20
T1655-3	3.00	3.10	3.20	3.00	3.10	3.20
T1655N-1	3.00	3.10	3.20	3.00	3.10	3.20
T2055-3	3.00	3.10	3.20	3.00	3.10	3.20
T2055-4	3.00	3.10	3.20	3.00	3.10	3.20
T2055-5	3.15	3.25	3.35	3.15	3.25	3.35
T2055M-5	3.15	3.25	3.35	3.15	3.25	3.35
T2855-3	3.15	3.25	3.35	3.15	3.25	3.35
T2855-4	2.60	2.70	2.80	2.60	2.70	2.80
T2855-5	2.60	2.70	2.80	2.60	2.70	2.80
T2855-6	3.15	3.25	3.35	3.15	3.25	3.35
T2855-7	2.60	2.70	2.80	2.60	2.70	2.80
T2855-8	3.15	3.25	3.35	3.15	3.25	3.35
T2855N-1	3.15	3.25	3.35	3.15	3.25	3.35
T3255-3	3.00	3.10	3.20	3.00	3.10	3.20
T3255-4	3.00	3.10	3.20	3.00	3.10	3.20
T3255-4	3.00	3.10	3.20	3.00	3.10	3.20
T3255-5	3.00	3.10	3.20	3.00	3.10	3.20
T3255N-1	3.00	3.10	3.20	3.00	3.10	3.20
T4055-1	3.40	3.50	3.60	3.40	3.50	3.60
T4055-2	3.40	3.50	3.60	3.40	3.50	3.60

**NOTES:**

- DIMENSIONING & TOLERANCING CONFORM TO ASME Y14.5M-1994.
- ALL DIMENSIONS ARE IN MILLIMETERS. ANGLES ARE IN DEGREES.
- N IS THE TOTAL NUMBER OF TERMINALS.
- THE TERMINAL #1 IDENTIFIER AND TERMINAL NUMBERING CONVENTION SHALL CONFORM TO JEDEC 95-1 SPP-012. DETAILS OF TERMINAL #1 IDENTIFIER ARE OPTIONAL, BUT MUST BE LOCATED WITHIN THE ZONE INDICATED. THE TERMINAL #1 IDENTIFIER MAY BE EITHER A MOLD OR MARKED FEATURE.
- DIMENSION b APPLIES TO METALLIZED TERMINAL AND IS MEASURED BETWEEN 0.25 mm AND 0.30 mm FROM TERMINAL TIP.
- ND AND NE REFER TO THE NUMBER OF TERMINALS ON EACH D AND E SIDE RESPECTIVELY.
- DEPOPULATION IS POSSIBLE IN A SYMMETRICAL FASHION.
- COPLANARITY APPLIES TO THE EXPOSED HEAT SINK SLUG AS WELL AS THE TERMINALS.
- DRAWING CONFORMS TO JEDEC MO220, EXCEPT EXPOSED PAD DIMENSION FOR T2855-3, T2855-6, T4055-1 AND T4055-2.
- WARPAGE SHALL NOT EXCEED 0.10 mm.
- MARKING IS FOR PACKAGE ORIENTATION REFERENCE ONLY.
- NUMBER OF LEADS SHOWN ARE FOR REFERENCE ONLY.
- LEAD CENTERLINES TO BE AT TRUE POSITION AS DEFINED BY BASIC DIMENSION 'e', ±0.05.

-DRAWING NOT TO SCALE-

TITLE: PACKAGE OUTLINE, 16, 20, 28, 32, 40L THIN QFN, 5x5x0.8mm			
APPROVAL	DOCUMENT CONTROL NO.	REV.	
	21-0140	K	2/2

Maxim cannot assume responsibility for use of any circuitry other than circuitry entirely embodied in a Maxim product. No circuit patent licenses are implied. Maxim reserves the right to change the circuitry and specifications without notice at any time.

20 **Maxim Integrated Products, 120 San Gabriel Drive, Sunnyvale, CA 94086 408-737-7600**