

FEATURES

- 1800 Ω Differential Transimpedance
- 3 mApp Maximum Input Current
- 14 pA/ $\sqrt{\text{Hz}}$ Input Noise Current Density
- Single -5.2 V Power Supply
- Low Group Delay
- Outputs DC or AC Coupled

APPLICATIONS

- SONET/SDH OC-192 /STM-64 VSR, Short-Reach, Intermediate-Reach, and Long-Reach Receivers
- 10 Gb/s Ethernet
- Fiber optic receivers, transceivers, and transponders

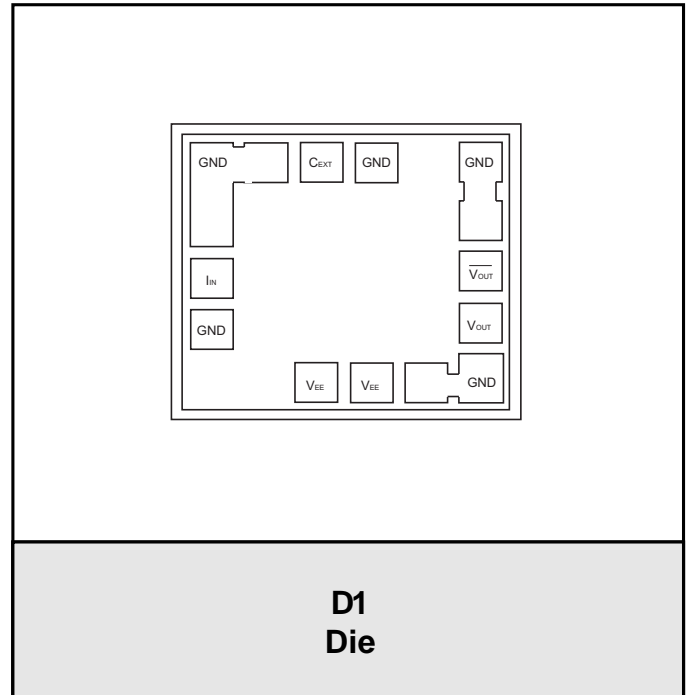

PRODUCT DESCRIPTION

The ANADIGICS ATA7603 is a -5.2 V high-speed transimpedance amplifier (TIA) designed for 10 Gb/s optical receiver applications available in bare die form and manufactured using an InGaP based HBT process. The device is used in conjunction with a photodetector to convert an optical signal into a differential output voltage that can be AC or DC coupled to a post amplifier. The

ATA7603 has an internal overload support circuit and can accept optical inputs as high as $+3$ dBm. With its low noise and high optical overload capability, the device is well suited for 10 Gb/s Ethernet and OC-192 Very Short-Reach (VSR), Short-Reach, Intermediate-Reach and Long-Reach optical receivers, transceivers and transponders.

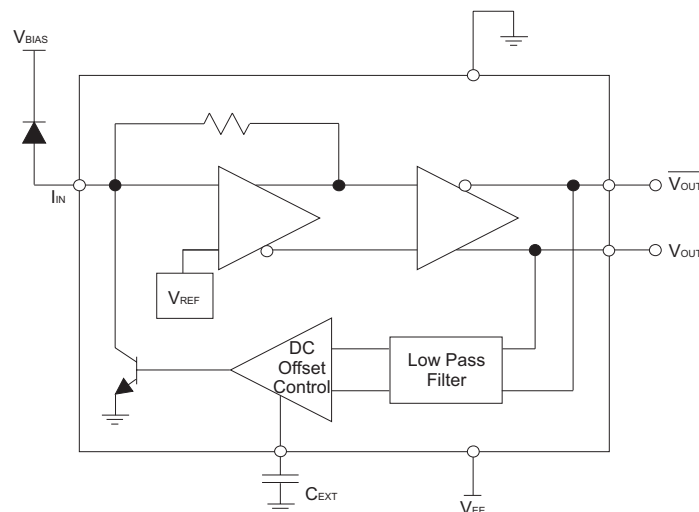

Figure 1: Circuit Block Diagram

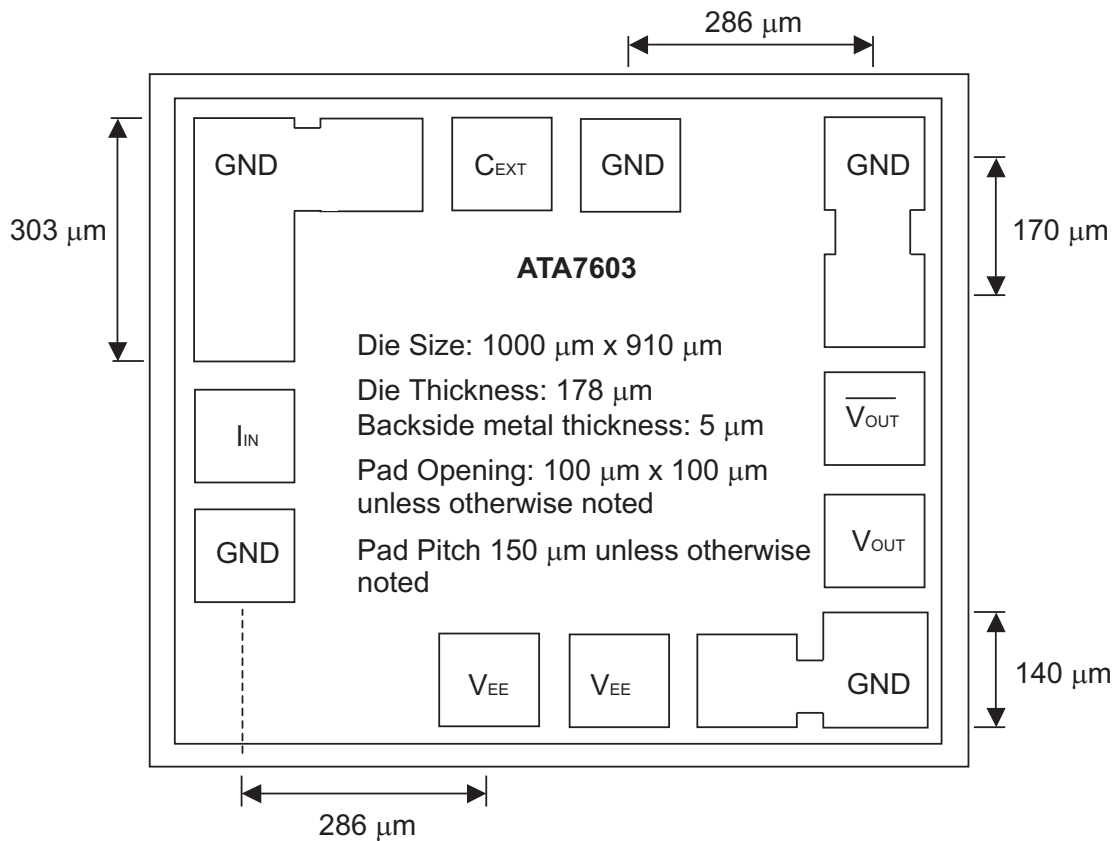

Figure 2: Die Size and Layout

Table 1: Pad Description

| PAD | DESCRIPTION | COMMENTS |
|------------------------------------|--------------------------------------|--------------------------------|
| V _{EE} | Negative Supply Voltage | -5.2 V |
| GND | Ground | |
| I _{IN} | TIA Input | Photocurrent input |
| C _{EXT} | Connection for an External Capacitor | Sets the low frequency cutoff |
| V _{OUT} | Non-inverted Output Voltage | Logical '1' with optical input |
| $\overline{\text{V}}_{\text{OUT}}$ | Inverted Output Voltage | Logical '0' with optical input |

ELECTRICAL CHARACTERISTICS

Table 2: Absolute Minimum and Maximum Ratings

| PARAMETER | MIN | MAX | UNIT |
|------------------------------------|------|-----|------|
| DC Power Supply (V_{EE}) | -7.0 | 1.0 | V |
| Storage Temperature | -65 | 125 | °C |
| DC Input Current | - | 5.0 | mA |
| ESD Sensitivity (Human Body Model) | 100 | - | V |

Stresses in excess of the absolute ratings may cause permanent damage. Functional operation is not implied under these conditions. Exposure to absolute ratings for extended periods of time may adversely affect reliability.

Table 3: Recommended Operating Conditions

| PARAMETER | MIN | TYP | MAX | UNIT |
|--------------------------------------|-------|-------|-------|----------|
| Operating Voltage Range | -5.50 | -5.2 | -4.90 | V |
| Operating Temperature Range | -40 | - | 85 | °C |
| Die Attach Temperature | - | - | 260 | °C |
| Photodiode Capacitance (PIN + stray) | - | 0.225 | 0.3 | pF |
| Photodiode Responsivity | - | 0.92 | - | A/W |
| Photodiode Contact Resistance | - | 10 | 15 | Ω |
| Input Bondwire Inductance | 0.7 | 1.0 | - | nH |

The device may be operated safely over these conditions; however, parametric performance is guaranteed only over the conditions defined in the electrical specifications.

Table 4: DC Electrical Specifications

| PARAMETER | MIN | TYP | MAX | UNIT |
|-------------------------------------|-----|------|-----|------|
| Supply Current (DC Coupled Outputs) | - | 95 | 120 | mA |
| Input Offset Voltage | - | -3.7 | - | V |
| Output Offset Voltage (both ports) | - | -0.2 | - | V |

Table 5: AC Electrical Specifications ⁽¹⁾

| PARAMETER | MIN | TYP | MAX | UNIT |
|---|------|------|-----|----------------|
| Small Signal Differential Transimpedance ($R_L = 100 \Omega$) | 1300 | 1800 | - | Ω |
| Small Signal Bandwidth | 8.5 | 9.5 | - | GHz |
| Low Frequency Cutoff ⁽²⁾ | - | 30 | - | kHz |
| Peaking | - | - | 1.0 | dB |
| Group Delay Deviation (500 MHz to 8.0 GHz) ⁽³⁾ | - | 30 | - | ps |
| Group Delay Deviation (8 GHz to 9.5 GHz) ⁽³⁾ | - | 40 | - | ps |
| Maximum Input Current | - | - | 3.0 | mApp |
| Optical Overload ⁽⁴⁾ | - | +3 | - | dBm |
| Input Referred RMS Noise Current ⁽⁵⁾ | - | 1.4 | - | μ A |
| Average Input Referred Noise Current Density ⁽⁵⁾ | - | 14 | 20 | pA/ \sqrt Hz |
| Optical Sensitivity ⁽⁴⁾ | - | -19 | - | dBm |
| Maximum Single-ended Output Voltage Swing | - | 400 | - | mVpp |
| Output Return Loss (10 MHz to 8 GHz) | - | - | -10 | dB |
| Output Return Loss (8 MHz to 20 GHz) | - | - | -5 | dB |

Notes:

- (1) The specifications are based upon the use of a PIN photodiode with a responsivity of 0.92 A/W and a capacitance of $C_{DIODE} + C_{STRAY} = 0.3$ pF max connected to I_{IN} via a 1.0 nH bond wire.
- (2) With the use of an external 10 nF capacitor.
- (3) Maximum value - minimum value
- (4) Measured at 10^{-10} BER with a $2^{23} - 1$ PRBS at 10 Gb/s
- (5) Bandwidth = 9 GHz

PERFORMANCE DATA

Figure 3: Typical Small Signal Frequency Response

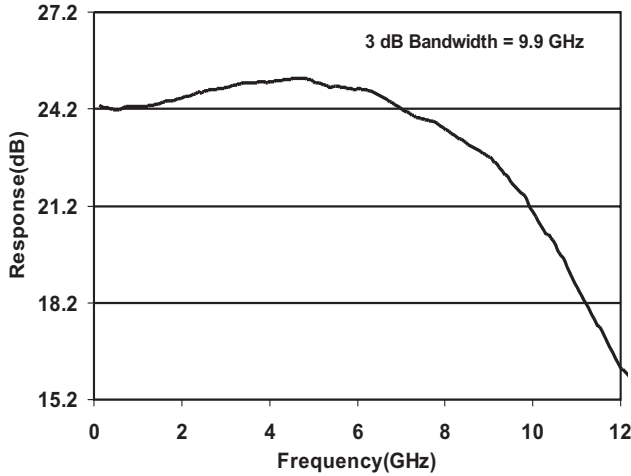

Figure 4: Typical Small Signal Group Delay

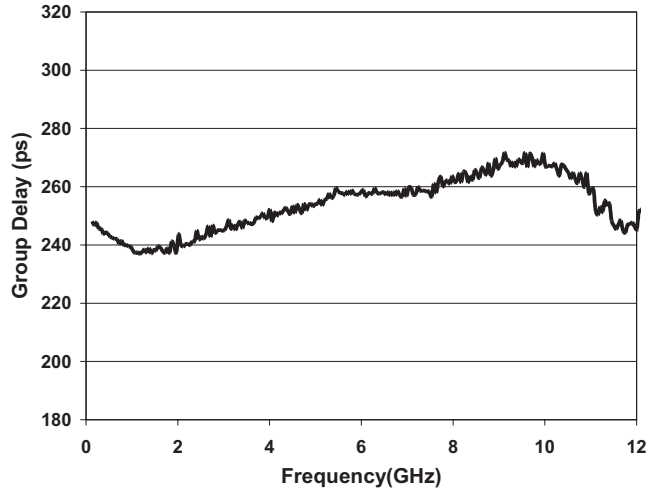

Figure 5: Bandwidth vs. Input Inductance

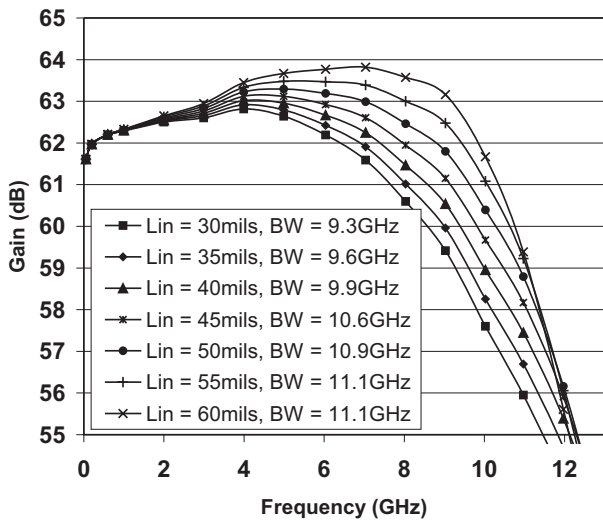

Figure 6: Differential Transimpedance vs. Input Current

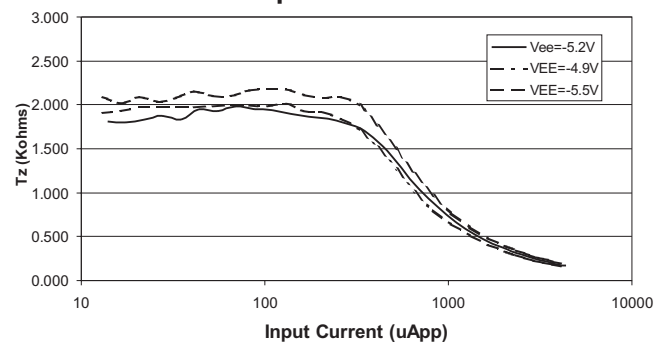

Figure 7: Differential Output Voltage vs. Input Current up to 1000 μ App

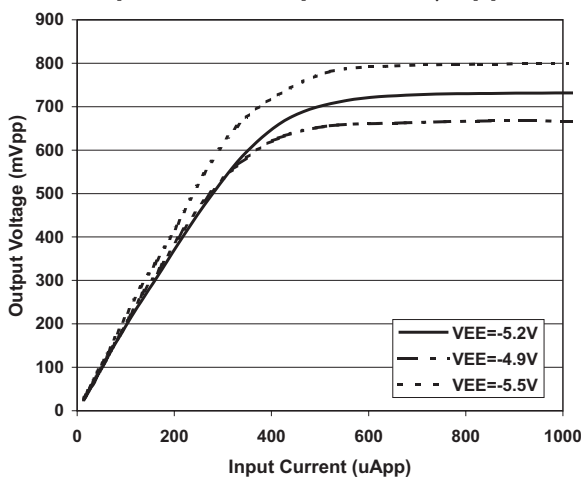

Figure 8: Differential Output Voltage vs. Input Current up to 4000 μ App

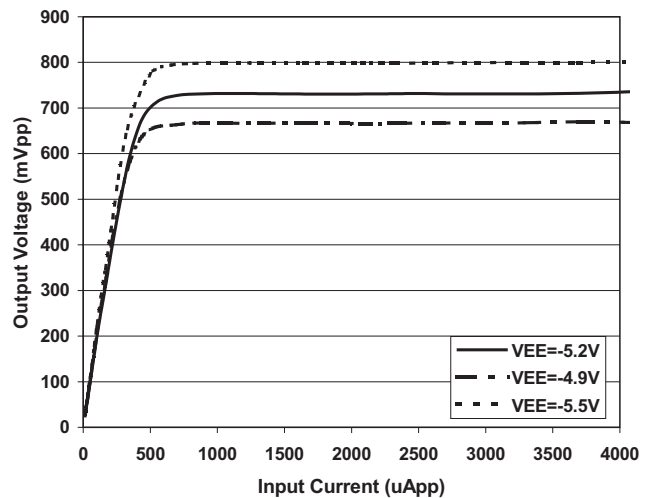

Figure 9: Eye Diagram with an Optical Input Power of -18 dBm

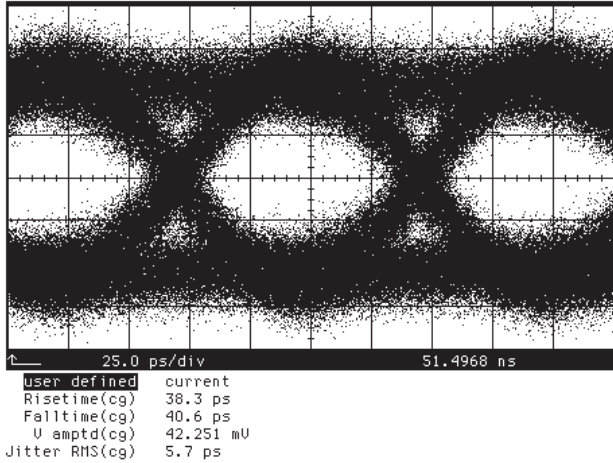

Figure 10: Eye Diagram with an Optical Input Power of -10 dBm

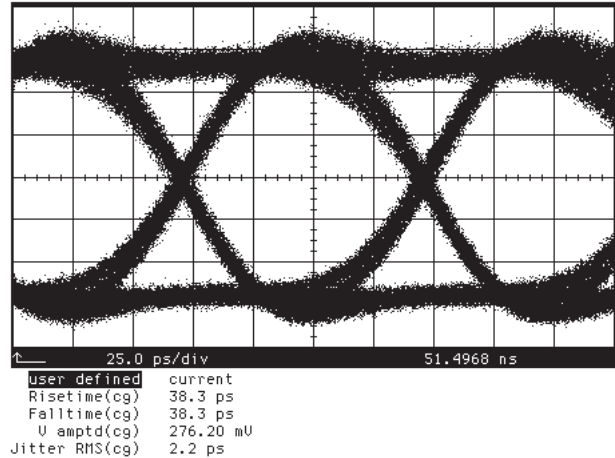

Figure 11: Eye Diagram with an Optical Input Power of 0 dBm

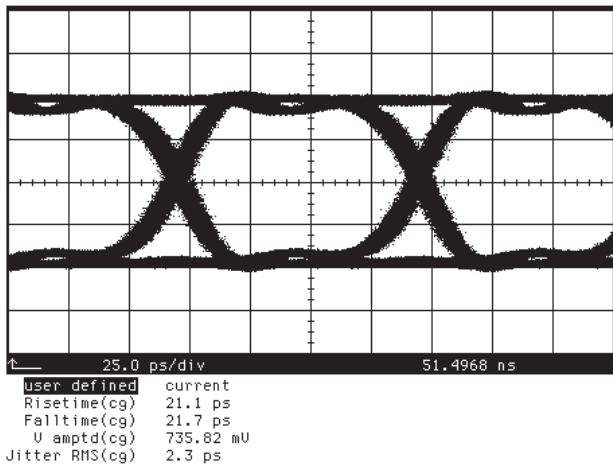

Figure 12: Eye Diagram with an Optical Input Power of +3 dBm

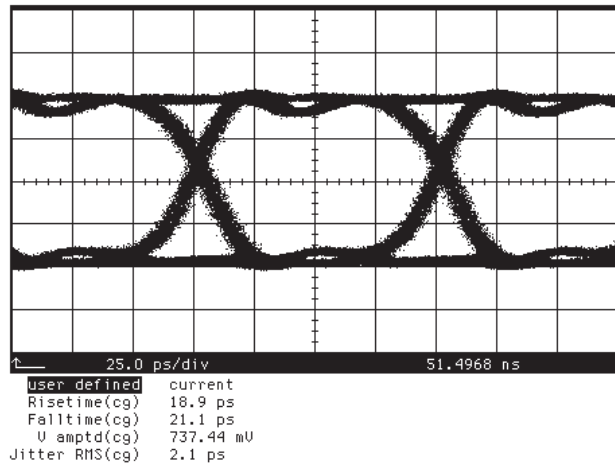

Figure 13: Eye Diagram with an Optical Input Power of +4 dBm

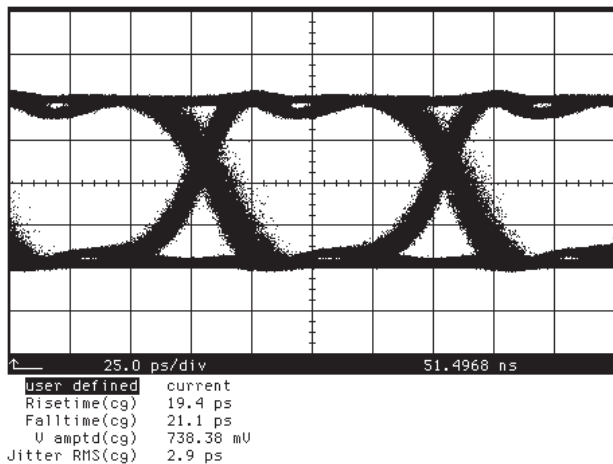
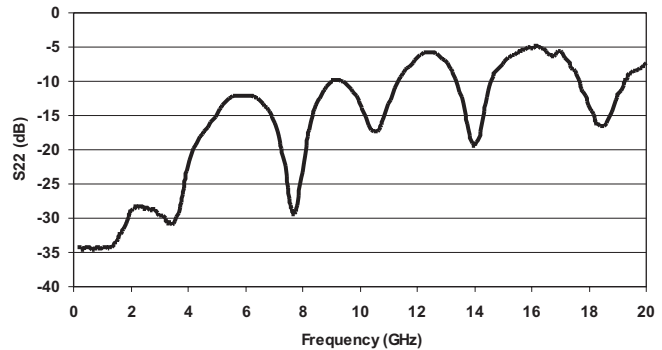

Figure 14: S22 from Evaluation Test Fixture



APPLICATION INFORMATION

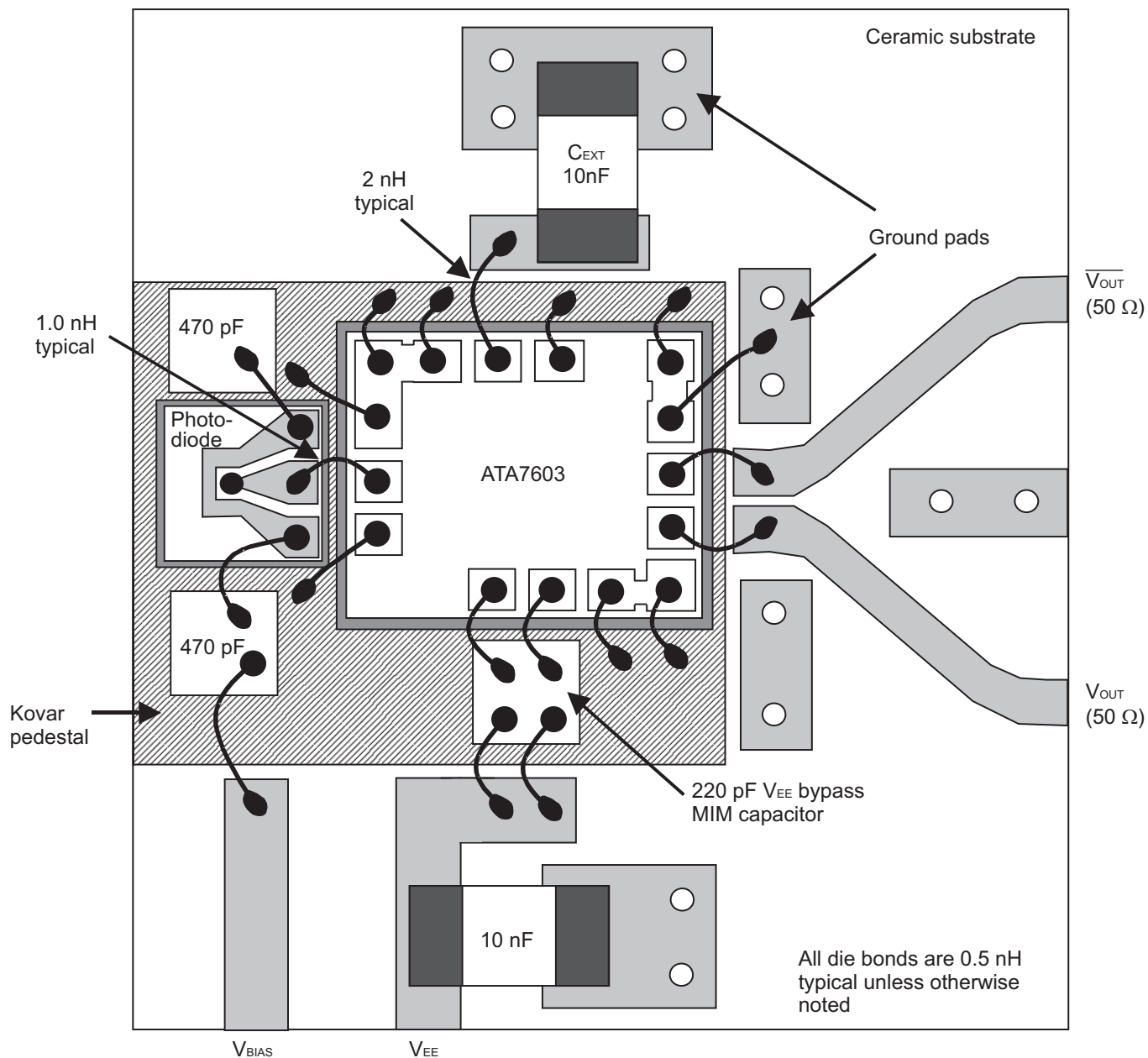

Figure 15: Bonding Diagram

PACKAGING

The ATA7603 is provided as bare die. For optimum performance, the die should be packaged in a hermetic enclosure and a low inductance ground plane should be made available for power supply bypassing and ground bonds. When packaging the ATA7603, the temperature of the die must be kept below 260 °C to ensure device reliability. The ATA7603 has backside metal but no ground vias are connected to the backside of the die, so it is critical to bond all of the ground pads to reduce ground inductance. The die can be attached to the substrate using epoxy or solder. A good thermally conductive, silver-filled epoxy is recommended for epoxy mounting. If solder is used for die attach, exposure to temperatures at or above 260 °C must be limited to ensure the device reliability. A soft silicon/rubber tip collet should be used for die mounting, although tweezers can be used with extreme care.

Thermosonic ball bonding, at a stage temperature of 150 to 175 °C, with 1 to 1.3 mil gold wire, is the recommended interconnect technique. The bond force, time, and ultrasonic power are all critical parameters and should be optimized to achieve the best bonding performance. The recommended bonding parameters are:

Stage Temperature: 175 °C
 Bond Time: 15 ms
 Bond Ultrasonic Power: 70 mW
 Bond Force: 70 g
 Bond Velocity: 60 mils/ms

I_{IN} Connection

For optimal performance, the bond wire from the photodetector to I_{IN} should be around 1nH. As the inductance of this connection increases beyond 1nH, more gain peaking will occur and the group delay performance will degrade.

V_{EE} Connections

In order to achieve optimal performance, the V_{EE} supply pads must be bypassed as close to the chip as possible with one or two high resonant frequency, low value capacitance, MIM capacitors. In either case, both V_{EE} bond pads need to be connected to reduce the supply bond wire inductance.

V_{OUT} and $\overline{V_{OUT}}$ Connections

The ATA7603 provides a differential output that can be AC or DC coupled to the next stage of the receiver. The output bond wires should be kept below 1 nH for the best performance. If the device is being used in a single-ended configuration, the unused output port must be terminated into 50 Ω.

C_{EXT} Connection

In order to achieve the desired low frequency cutoff, an external capacitor is required. A low inductance multilayer chip capacitor of value 10 nF is recommended.

TYPICAL APPLICATION CIRCUITS

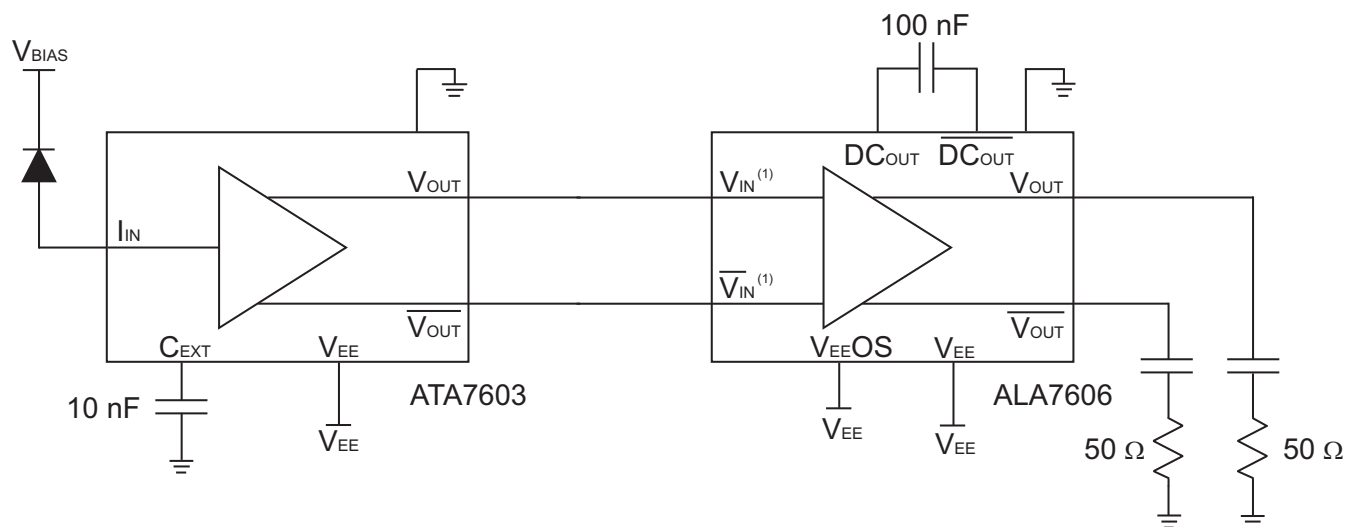

Figure 16: ATA7603 DC Coupled to the ALA7606

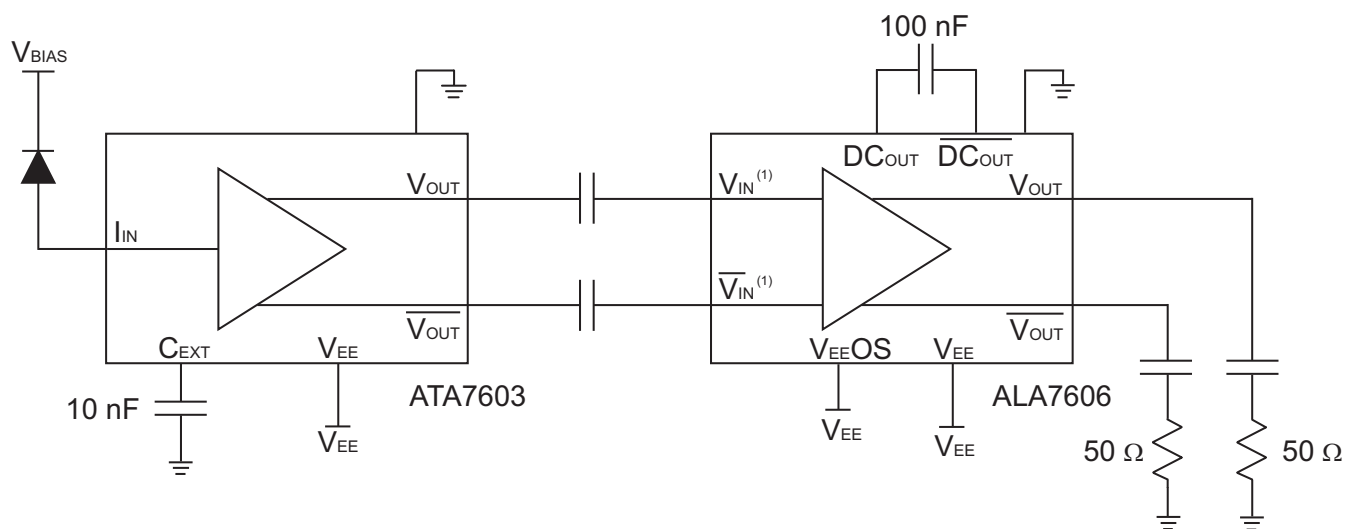

Figure 17: ATA7603 AC Coupled to the ALA7606

Notes:

(1) The ALA7606 is a non-inverting amplifier and V_{IN} and \overline{V}_{IN} can be interchanged.

ATA7603

NOTES

NOTES

ORDERING INFORMATION

| ORDER NUMBER | TEMPERATURE RANGE | PACKAGE DESCRIPTION | COMPONENT PACKAGING |
|--------------|-------------------|---------------------|---------------------|
| ATA7603D1 | -40 °C to +85 °C | D1 | Die |

**ANADIGICS, Inc.**

141 Mount Bethel Road
 Warren, New Jersey 07059, U.S.A.
 Tel: +1 (908) 668-5000
 Fax: +1 (908) 668-5132

URL: <http://www.anadigics.com>
 E-mail: Mktg@anadigics.com

IMPORTANT NOTICE

ANADIGICS, Inc. reserves the right to make changes to its products or to discontinue any product at any time without notice. The product specifications contained in Advanced Product Information sheets and Preliminary Data Sheets are subject to change prior to a product's formal introduction. Information in Data Sheets have been carefully checked and are assumed to be reliable; however, ANADIGICS assumes no responsibilities for inaccuracies. ANADIGICS strongly urges customers to verify that the information they are using is current before placing orders.

WARNING

ANADIGICS products are not intended for use in life support appliances, devices or systems. Use of an ANADIGICS product in any such application without written consent is prohibited.