



+2.7V to +5.25V, Low-Power, 10-Bit Serial ADCs in SO-8

General Description

The MAX1242/MAX1243 are low-power, 10-bit analog-to-digital converters (ADCs) available in 8-pin packages. They operate with a single +2.7V to +5.25V supply and feature a 7.5 μ s successive-approximation ADC, a fast track/hold (1.5 μ s), an on-chip clock, and a high-speed, 3-wire serial interface.

Power consumption is only 3mW ($V_{DD} = 3V$) at the 73ksps maximum sampling speed. A 2 μ A shutdown mode reduces power at slower throughput rates.

The MAX1242 has an internal 2.5V reference, while the MAX1243 requires an external reference. The MAX1243 accepts signals from 0V to V_{REF} , and the reference input range includes the positive supply rail. An external clock accesses data from the 3-wire interface, which connects directly to standard microcontroller I/O ports. The interface is compatible with SPI™, QSPI™, and Microwire™.

Excellent AC characteristics and very low power combined with ease of use and small package size make these converters ideal for remote-sensor and data-acquisition applications, or for other circuits with demanding power consumption and space requirements. The MAX1242/MAX1243 are available in 8-pin DIP and SO packages.

Applications

Portable Data Logging Process Control Monitoring
 Test Equipment Temperature Measurement
 Isolated Data Acquisition

Pin Configuration

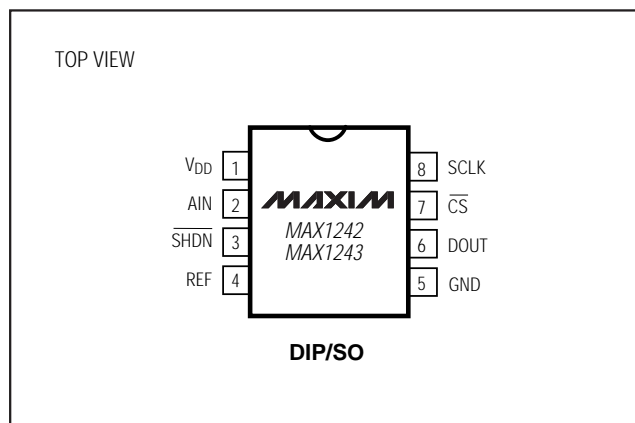

Features

- ◆ **+2.7V to +5.25V Single-Supply Operation**
- ◆ **10-Bit Resolution**
- ◆ **Internal 2.5V Reference (MAX1242)**
- ◆ **Small Footprint: 8-Pin DIP and SO Packages**
- ◆ **Low Power: 3.7mW (73ksps, MAX1242)
3mW (73ksps, MAX1243)
66 μ W (1ksps, MAX1243)
5 μ W (power-down mode)**
- ◆ **Internal Track/Hold**
- ◆ **SPI™/QSPI™/Microwire™ 3-Wire Serial Interface**
- ◆ **Pin-Compatible 12-Bit Upgrades:
MAX1240/MAX1241**

Ordering Information

PART	TEMP. RANGE	PIN-PACKAGE	INL (LSB)
MAX1242ACPA	0°C to +70°C	8 Plastic DIP	$\pm 1/2$
MAX1242BCPA	0°C to +70°C	8 Plastic DIP	± 1
MAX1242ACSA	0°C to +70°C	8 SO	$\pm 1/2$
MAX1242BCSA	0°C to +70°C	8 SO	± 1
MAX1242AEPA	-40°C to +85°C	8 Plastic DIP	$\pm 1/2$
MAX1242BEPA	-40°C to +85°C	8 Plastic DIP	± 1

Ordering Information continued at end of data sheet.

Note: Order the MAX1242A in place of the MAX1242C. Order the MAX1242B in place of the MAX1242D.

Functional Diagram

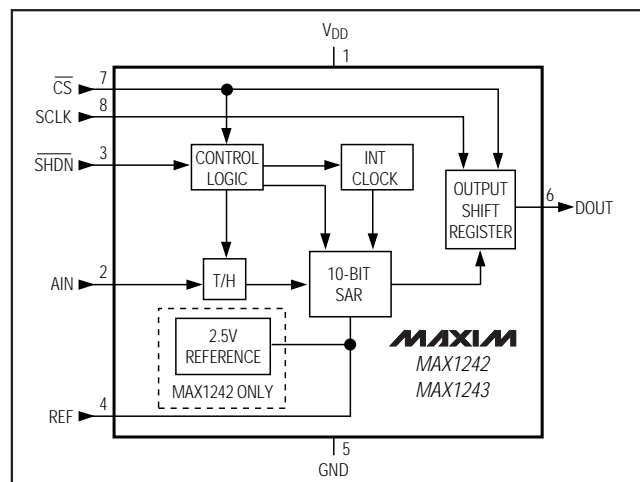

SPI and QSPI are trademarks of Motorola, Inc. Microwire is a trademark of National Semiconductor Corp.



Maxim Integrated Products 1

**For free samples & the latest literature: <http://www.maxim-ic.com>, or phone 1-800-998-8800.
 For small orders, phone 408-737-7600 ext. 3468.**

MAX1242/MAX1243

+2.7V to +5.25V, Low-Power, 10-Bit Serial ADCs in SO-8

ABSOLUTE MAXIMUM RATINGS

V _{DD} to GND	-0.3V to +6V
A _{IN} to GND	-0.3V to (V _{DD} + 0.3V)
REF to GND	-0.3V to (V _{DD} + 0.3V)
Digital Inputs to GND	-0.3V to +6V
DOUT to GND	-0.3V to (V _{DD} + 0.3V)
DOUT Current	±25mA
Continuous Power Dissipation (T _A = +70°C)	
Plastic DIP (derate 9.09mW/°C above +70°C)	727mW
SO (derate 5.88mW/°C above +70°C)	471mW
CERDIP (derate 8.00mW/°C above +70°C)	640mW

Operating Temperature Ranges

MAX1242/MAX1243_C_A	0°C to +70°C
MAX1242/MAX1243_E_A	-40°C to +85°C
MAX1242/MAX1243_MJA	-55°C to +125°C
Storage Temperature Range	-60°C to +150°C
Lead Temperature (soldering, 10sec)	+300°C

Stresses beyond those listed under "Absolute Maximum Ratings" may cause permanent damage to the device. These are stress ratings only, and functional operation of the device at these or any other conditions beyond those indicated in the operational sections of the specifications is not implied. Exposure to absolute maximum rating conditions for extended periods may affect device reliability.

ELECTRICAL CHARACTERISTICS

(V_{DD} = +2.7V to +5.25V; 73ksps; f_{SCLK} = 2.1MHz (50% duty cycle); MAX1242—4.7μF capacitor at REF pin, MAX1243—external reference; V_{REF} = 2.5V applied to REF pin; T_A = T_{MIN} to T_{MAX}; unless otherwise noted.)

PARAMETER	SYMBOL	CONDITIONS	MIN	TYP	MAX	UNITS
DC ACCURACY (Note1)						
Resolution			10			Bits
Relative Accuracy (Note 2)		MAX124_A			±0.5	LSB
		MAX124_B			±1.0	
Differential Nonlinearity	DNL	No missing codes over temperature			±1	LSB
Offset Error		MAX124_A			±1	LSB
		MAX124_B			±2	
Gain Error (Note 3)		MAX124_A			±1	LSB
		MAX124_B			±2	
Gain Temperature Coefficient				±0.25		ppm/°C
DYNAMIC SPECIFICATIONS (10kHz sine-wave input, 0V to 2.5p-p, 73ksps, f _{SCLK} = 2.1MHz)						
Signal-to-Noise Plus Distortion Ratio	SINAD			66		dB
Total Harmonic Distortion	THD	Up to the 5th harmonic		-70		dB
Spurious-Free Dynamic Range	SFDR			70		dB
Small-Signal Bandwidth		-3dB rolloff		2.25		MHz
Full-Power Bandwidth				1.0		MHz
CONVERSION RATE						
Conversion Time	t _{CONV}		5.5		7.5	μs
Track/Hold Acquisition Time	t _{ACQ}				1.5	μs
Throughput Rate		f _{SCLK} = 2.1MHz			73	ksps
Aperture Delay	t _{AP}	Figure 9		30		ns
Aperture Jitter				<50		ps
ANALOG INPUT						
Input Voltage Range			0		V _{REF}	V
Input Capacitance				16		pF

+2.7V to +5.25V, Low-Power, 10-Bit Serial ADCs in SO-8

ELECTRICAL CHARACTERISTICS (continued)

(V_{DD} = +2.7V to +5.25V; 73ksps; f_{SCLK} = 2.1MHz (50% duty cycle); MAX1242—4.7μF capacitor at REF pin, MAX1243—external reference; V_{REF} = 2.5V applied to REF pin; T_A = T_{MIN} to T_{MAX}; unless otherwise noted.)

PARAMETER	SYMBOL	CONDITIONS	MIN	TYP	MAX	UNITS	
INTERNAL REFERENCE (MAX1242 only)							
REF Output Voltage		T _A = +25°C (Note 4)	2.470	2.500	2.530	V	
REF Short-Circuit Current					30	mA	
REF Temperature Coefficient		MAX1242		±30		ppm/°C	
Load Regulation (Note 5)		0mA to 0.2mA output load		0.35		mV	
Capacitive Bypass at REF			4.7			μF	
EXTERNAL REFERENCE (V_{REF} = 2.5V)							
Input Voltage Range			1.00		V _{DD} + 50mV	V	
Input Current				100	150	μA	
Input Resistance			18	25		kΩ	
REF Input Current in Shutdown		$\overline{\text{SHDN}} = 0\text{V}$		±0.01	10	μA	
Capacitive Bypass at REF			0.1			μF	
DIGITAL INPUTS: SCLK, $\overline{\text{CS}}$, $\overline{\text{SHDN}}$							
SCLK, $\overline{\text{CS}}$ Input High Voltage	V _{IH}	V _{DD} ≤ 3.6V	2.0			V	
		V _{DD} > 3.6V	3.0				
SCLK, $\overline{\text{CS}}$ Input Low Voltage	V _{IL}				0.8	V	
SCLK, $\overline{\text{CS}}$ Input Hysteresis	V _{HYST}			0.2		V	
SCLK, $\overline{\text{CS}}$ Input Leakage	I _{IN}	V _{IN} = 0V or V _{DD}		±0.01	±1	μA	
SCLK, $\overline{\text{CS}}$ Input Capacitance	C _{IN}	(Note 6)			15	pF	
$\overline{\text{SHDN}}$ Input High Voltage	V _{SH}		V _{DD} - 0.4			V	
$\overline{\text{SHDN}}$ Input Low Voltage	V _{SL}				0.4	V	
$\overline{\text{SHDN}}$ Input Current		$\overline{\text{SHDN}} = 0\text{V}$ or V _{DD}			±4.0	μA	
$\overline{\text{SHDN}}$ Input Mid Voltage	V _{SM}		1.1		V _{DD} - 1.1	V	
$\overline{\text{SHDN}}$ Voltage, Floating	V _{FLT}	$\overline{\text{SHDN}} = \text{float}$		V _{DD} / 2		V	
$\overline{\text{SHDN}}$ Max Allowed Leakage, Mid Input		$\overline{\text{SHDN}} = \text{float}$			±100	nA	
DIGITAL OUTPUT: DOUT							
Output Voltage Low	V _{OL}	I _{SINK} = 5mA			0.4	V	
		I _{SINK} = 16mA			0.8		
Output Voltage High	V _{OH}	I _{SOURCE} = 0.5mA	V _{DD} - 0.5			V	
Three-State Leakage Current	I _L	$\overline{\text{CS}} = \text{V}_{\text{DD}}$		±0.01	±10	μA	
Three-State Output Capacitance	C _{OUT}	$\overline{\text{CS}} = \text{V}_{\text{DD}}$ (Note 6)			15	pF	
POWER REQUIREMENTS							
Supply Voltage	V _{DD}		2.7		5.25	V	
Supply Current	I _{DD}	Operating mode (MAX1242)	V _{DD} = 3.6V	1.4	2.0	mA	
			V _{DD} = 5.25V	1.8	3.0		
		Operating mode (MAX1243)	V _{DD} = 3.6V	0.9	1.5		
			V _{DD} = 5.25V	1.6	2.5		
		Power-down	V _{DD} = 3.6V	1.9	10		μA
			V _{DD} = 5.25V	3.5	15		
Power-Supply Rejection (Note 7)	PSR	V _{DD} = V _{DD} (min) to V _{DD} (max), full-scale input		±0.3		mV	

+2.7V to +5.25V, Low-Power, 10-Bit Serial ADCs in SO-8

TIMING CHARACTERISTICS

($V_{DD} = +2.7V$ to $+5.25V$, circuit of Figure 9, $T_A = T_{MIN}$ to T_{MAX} , unless otherwise noted.)

PARAMETER	SYMBOL	CONDITIONS	MIN	TYP	MAX	UNITS
Acquisition Time	t_{ACQ}	$\overline{CS} = V_{DD}$ (Note 8)	1.5			μs
SCLK Fall to Output Data Valid	t_{DO}	Figure 1, $C_{LOAD} = 50pF$	20		200	ns
		MAX124_ _C/E MAX124_ _M	20		240	
\overline{CS} Fall to Output Enable	t_{DV}	Figure 1, $C_{LOAD} = 50pF$			240	ns
\overline{CS} Rise to Output Disable	t_{TR}	Figure 2, $C_{LOAD} = 50pF$			240	ns
SCLK Clock Frequency	f_{SCLK}		0		2.1	MHz
SCLK Pulse Width High	t_{CH}		200			ns
SCLK Pulse Width Low	t_{CL}		200			ns
SCLK Low to \overline{CS} Fall Setup Time	t_{CS0}		50			ns
DOUT Rise to SCLK Rise (Note 6)	t_{STR}		0			ns
\overline{CS} Pulse Width	t_{CS}		240			ns

Note 1: Tested at $V_{DD} = +2.7V$.

Note 2: Relative accuracy is the deviation of the analog value at any code from its theoretical value after the full-scale range and offset have been calibrated.

Note 3: Offset nulled.

Note 4: Sample tested to 0.1% AQL.

Note 5: External load should not change during conversion for specified accuracy.

Note 6: Guaranteed by design. Not subject to production testing.

Note 7: Measured as $[V_{FS}(V_{DD}(\min)) - V_{FS}(V_{DD}(\max))]$.

Note 8: To guarantee acquisition time, t_{ACQ} is the maximum time the device takes to acquire the signal, and is also the minimum time needed for the signal to be acquired.

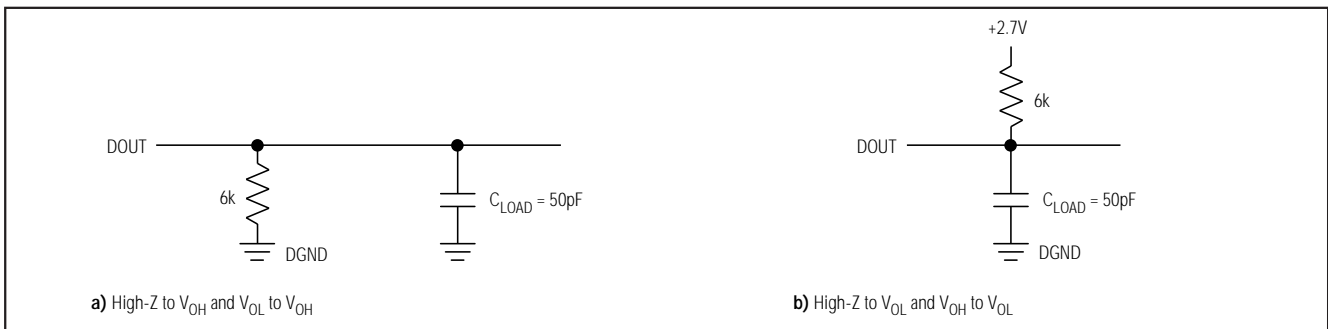

Figure 1. Load Circuits for DOUT Enable Time

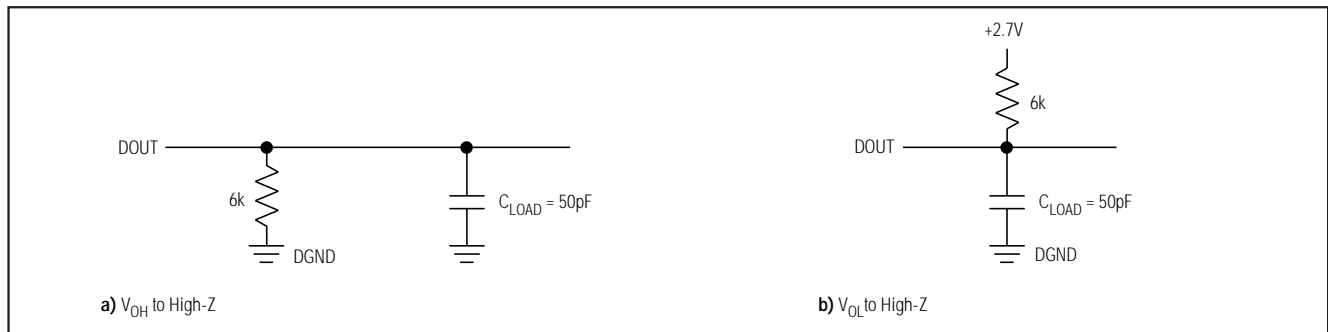

Figure 2. Load Circuits for DOUT Disable Time

+2.7V to +5.25V, Low-Power, 10-Bit Serial ADCs in SO-8

MAX1242/MAX1243

Typical Operating Characteristics

($V_{DD} = +3.0V$, $V_{REF} = 2.5V$, $f_{SCLK} = 2.1MHz$, $C_{LOAD} = 20pF$, $T_A = +25^\circ C$, unless otherwise noted.)

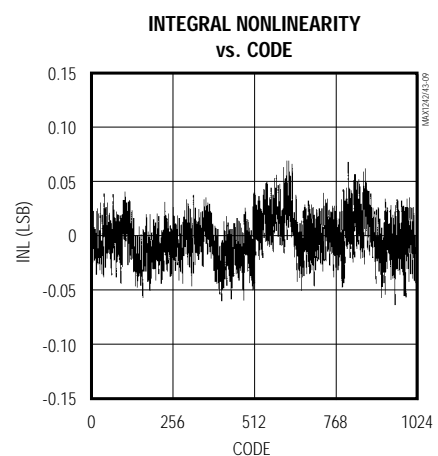
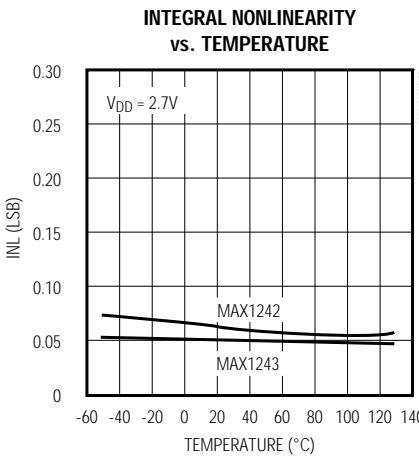
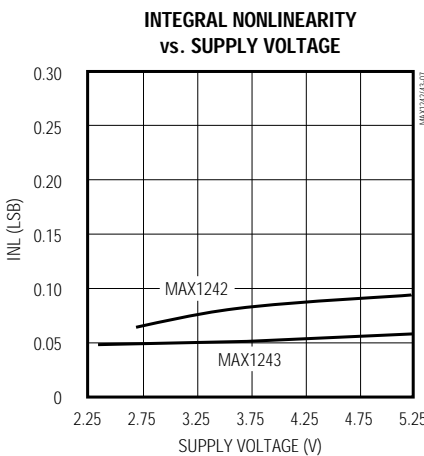
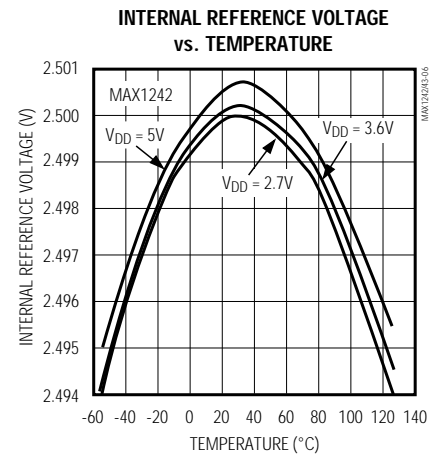
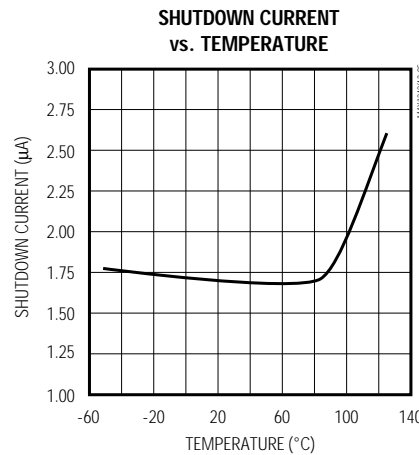
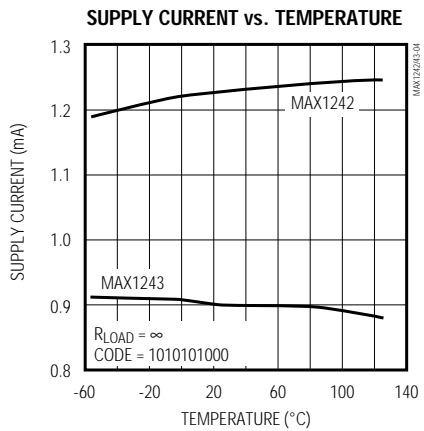
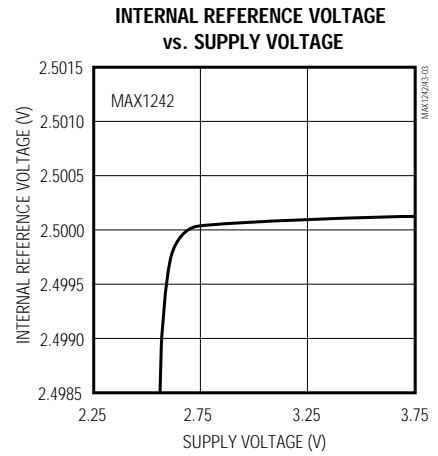
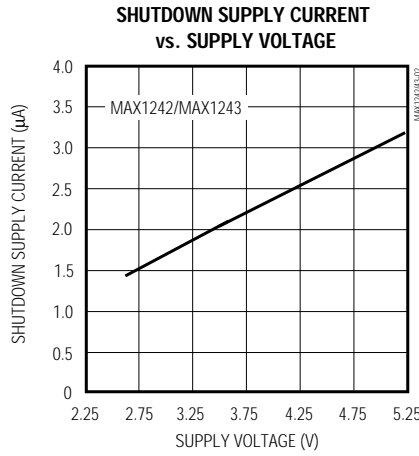
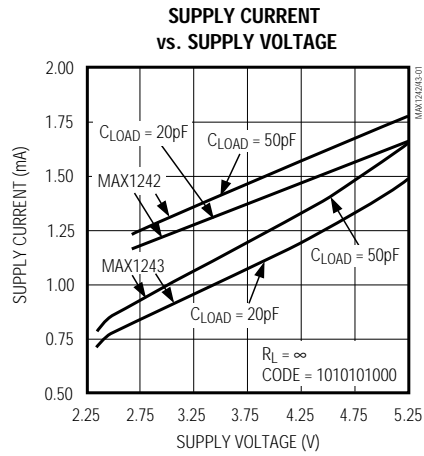

+2.7V to +5.25V, Low-Power, 10-Bit Serial ADCs in SO-8

Pin Description

PIN	NAME	FUNCTION
1	V _{DD}	Positive Supply Voltage: +2.7V to +5.25V
2	A _{IN}	Sampling Analog Input, 0V to V _{REF} range
3	$\overline{\text{SHDN}}$	Three-Level Shutdown Input. Pulling $\overline{\text{SHDN}}$ low shuts the MAX1242/MAX1243 down to 15 μ A (max) supply current. Both MAX1242 and MAX1243 are fully operational with either $\overline{\text{SHDN}}$ high or floating. For the MAX1242, pulling $\overline{\text{SHDN}}$ high enables the internal reference, and letting $\overline{\text{SHDN}}$ float disables the internal reference and allows for the use of an external reference.
4	REF	Reference Voltage for Analog-to-Digital Conversion. Internal 2.5V reference output for MAX1242; bypass with a 4.7 μ F capacitor. External reference voltage input for MAX1243, or for MAX1242 with the internal reference disabled. Bypass REF with a minimum of 0.1 μ F when using an external reference.
5	GND	Analog and Digital Ground
6	DOUT	Serial-Data Output. Data changes state at SCLK's falling edge. High impedance when $\overline{\text{CS}}$ is high.
7	$\overline{\text{CS}}$	Active-Low Chip Select. Initiates conversions on the falling edge. When $\overline{\text{CS}}$ is high, DOUT is high impedance.
8	SCLK	Serial-Clock Input. SCLK clocks data out at rates up to 2.1MHz.

Detailed Description

Converter Operation

The MAX1242/MAX1243 use an input track/hold (T/H) and successive-approximation register (SAR) circuitry to convert an analog input signal to a digital 10-bit output. Figure 3 shows the MAX1242/MAX1243 in their simplest configuration. The MAX1242/MAX1243 convert input signals in the 0V to V_{REF} range in 9 μ s, including T/H acquisition time. The MAX1242's internal reference is trimmed to 2.5V, while the MAX1243 requires an external reference. Both devices accept external reference voltages from 1.0V to V_{DD}. The serial interface requires only three digital lines (SCLK, $\overline{\text{CS}}$, and DOUT) and provides an easy interface to microprocessors (μ Ps).

The MAX1242/MAX1243 have two modes: normal and shutdown. Pulling $\overline{\text{SHDN}}$ low shuts the device down and reduces supply current below 10 μ A (V_{DD} \leq 3.6V), while pulling $\overline{\text{SHDN}}$ high or leaving it open puts the devices into operational mode. A conversion is initiated by pulling $\overline{\text{CS}}$ low. The conversion result is available at DOUT in unipolar serial format. The serial-data stream consists of a high bit, signaling the end of conversion (EOC), followed by the data bits (MSB first).

Analog Input

Figure 4 illustrates the sampling architecture of the analog-to-digital converter's (ADC's) comparator. The full-scale input voltage is set by the voltage at REF.

Track/Hold

In track mode, the analog signal is acquired and stored in the internal hold capacitor. In hold mode, the T/H switch opens and maintains a constant input to the ADC's SAR section.

During acquisition, the analog input A_{IN} charges capacitor C_{HOLD}. Bringing $\overline{\text{CS}}$ low ends the acquisition interval. At this instant, the T/H switches the input side of C_{HOLD} to GND. The retained charge on C_{HOLD} represents a sample of the input, unbalancing node ZERO at the comparator's input.

In hold mode, the capacitive digital-to-analog converter (DAC) adjusts during the remainder of the conversion cycle to restore node ZERO to 0V within the limits of 10-bit resolution. This action is equivalent to transferring a charge from C_{HOLD} to the binary-weighted capacitive DAC, which in turn forms a digital representation of the analog input signal. At the conversion's end, the input side of C_{HOLD} switches back to A_{IN}, and C_{HOLD} charges to the input signal again.

The time required for the T/H to acquire an input signal is a function of how quickly its input capacitance is charged. If the input signal's source impedance is high, the acquisition time lengthens, and more time must be allowed between conversions. The acquisition time, t_{ACQ}, is the maximum time the device takes to acquire the signal and the minimum time needed for the signal to be acquired. Acquisition time is calculated by:

$$t_{ACQ} = 7(R_S + R_{IN}) \times 16pF$$

+2.7V to +5.25V, Low-Power, 10-Bit Serial ADCs in SO-8

MAX1242/MAX1243

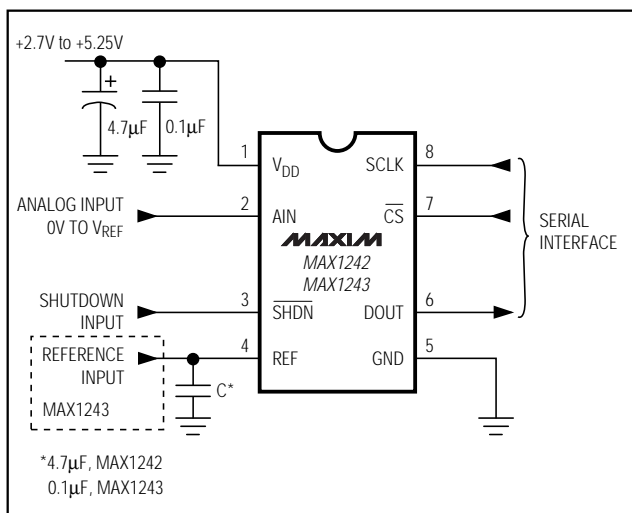

Figure 3. Operational Diagram

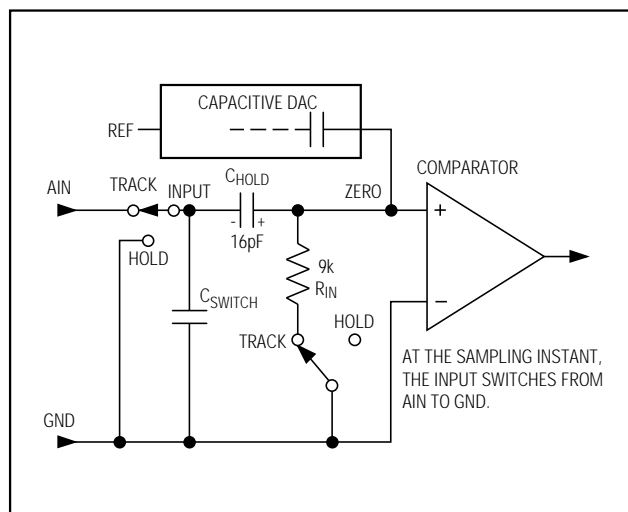

Figure 4. Equivalent Input Circuit

where $R_{IN} = 9k\Omega$, R_S = the input signal's source impedance, and t_{ACQ} is never less than $1.5\mu s$. Source impedances below $4k\Omega$ do not significantly affect the ADC's AC performance.

Higher source impedances can be used if a $0.01\mu F$ capacitor is connected to the analog input. Note that the input capacitor forms an RC filter with the input source impedance, limiting the ADC's input signal bandwidth.

Input Bandwidth

The ADC's input tracking circuitry has a 2.25MHz small-signal bandwidth, so it is possible to digitize high-speed transient events and measure periodic signals with bandwidths exceeding the ADC's sampling rate by using undersampling techniques. To avoid aliasing of unwanted high-frequency signals into the frequency band of interest, anti-alias filtering is recommended.

Analog Input Protection

Internal protection diodes, which clamp the analog input to V_{DD} and GND, allow the input to swing from $GND - 0.3V$ to $V_{DD} + 0.3V$ without damage. However, for accurate conversions near full scale, the input must not exceed V_{DD} by more than 50mV, or be lower than GND by 50mV.

If the analog input exceeds 50mV beyond the supplies, limit the input current to 2mA.

Internal Reference (MAX1242)

The MAX1242 has an on-chip voltage reference trimmed to 2.5V. The internal reference output is connected to REF and also drives the internal capacitive DAC. The output can be used as a reference voltage source for other components and can source up to $400\mu A$. Bypass REF with a $4.7\mu F$ capacitor. Larger capacitors increase wake-up time when exiting shutdown (see *Using SHDN to Reduce Supply Current*). The internal reference is enabled by pulling the SHDN pin high. Letting SHDN float disables the internal reference, which allows the use of an external reference, as described in the *External Reference* section.

External Reference

The MAX1242/MAX1243 operate with an external reference at the REF pin. To use the MAX1242 with an external reference, disable the internal reference by letting SHDN float. Stay within the voltage range $1.0V$ to V_{DD} to achieve specified accuracy. The minimum input impedance is $18k\Omega$ for DC currents. During conversion, the external reference must be able to deliver up to $250\mu A$ of DC load current and have an output impedance of 10Ω or less. The recommended minimum value for the bypass capacitor is $0.1\mu F$. If the reference has higher output impedance or is noisy, bypass it close to the REF pin with a $4.7\mu F$ capacitor.

+2.7V to +5.25V, Low-Power, 10-Bit Serial ADCs in SO-8

Serial Interface

Initialization after Power-Up and Starting a Conversion

When power is first applied, and if $\overline{\text{SHDN}}$ is not pulled low, it takes the fully discharged $4.7\mu\text{F}$ reference bypass capacitor up to 20ms to provide adequate charge for specified accuracy. With an external reference, the internal reset time is $10\mu\text{s}$ after the power supplies have stabilized. No conversions should be performed during these times.

To start a conversion, pull $\overline{\text{CS}}$ low. At $\overline{\text{CS}}$'s falling edge, the T/H enters its hold mode and a conversion is initiated. After an internally timed conversion period, the end of conversion is signaled by DOUT pulling high. Data can then be shifted out serially with the external clock.

Using $\overline{\text{SHDN}}$ to Reduce Supply Current

Power consumption can be reduced significantly by shutting down the MAX1242/MAX1243 between conversions. Figure 6 shows a plot of average supply current vs. conversion rate. Because the MAX1243 uses an external reference voltage (assumed to be present continuously), it "wakes up" from shutdown more quickly, providing lower average supply currents. The wake-up time, t_{WAKE} , is the time from $\overline{\text{SHDN}}$ deasserted to the time when a conversion may be initiated (Figure 5). For the MAX1242, this time depends on the time in shutdown (Figure 7) because the external $4.7\mu\text{F}$ reference bypass capacitor loses charge slowly during shutdown. The MAX1243's wake-up time is largely dependent on the external reference's power-up time. If the external reference is not shut down, the wake-up time is approximately $4\mu\text{s}$.

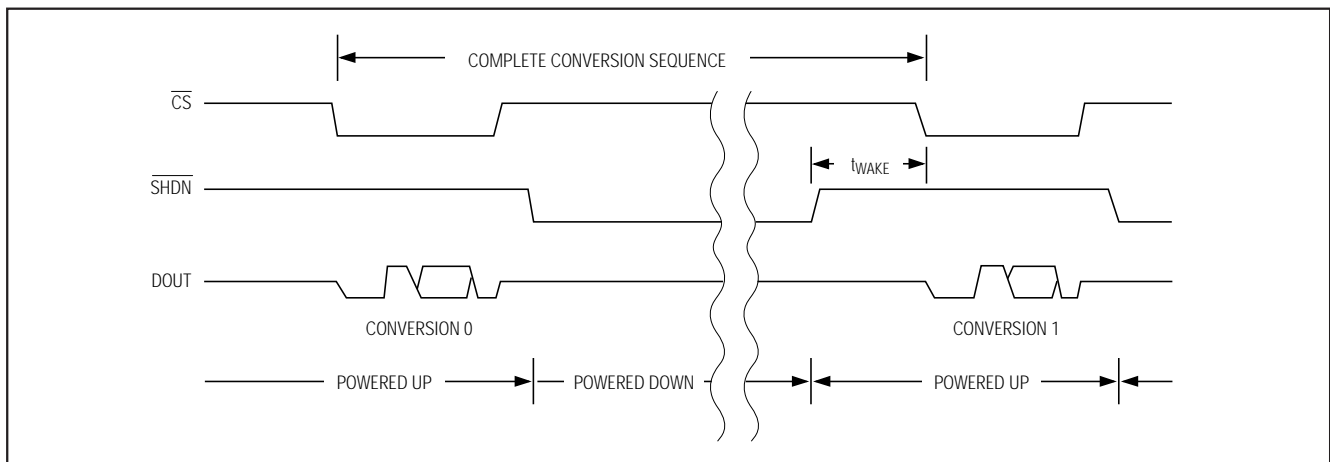

Figure 5. Shutdown Sequence

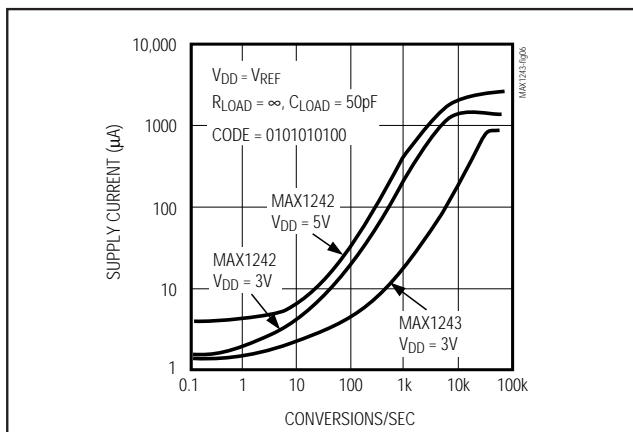

Figure 6. Average Supply Current vs. Conversion Rate

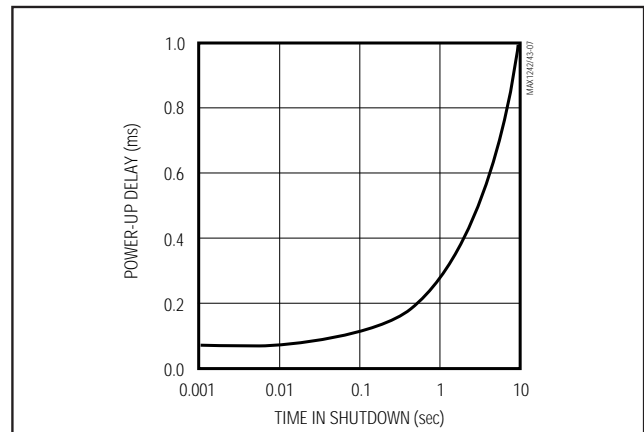

Figure 7. Typical Reference-Buffer Power-Up Delay vs. Time in Shutdown

+2.7V to +5.25V, Low-Power, 10-Bit Serial ADCs in SO-8

MAX1242/MAX1243

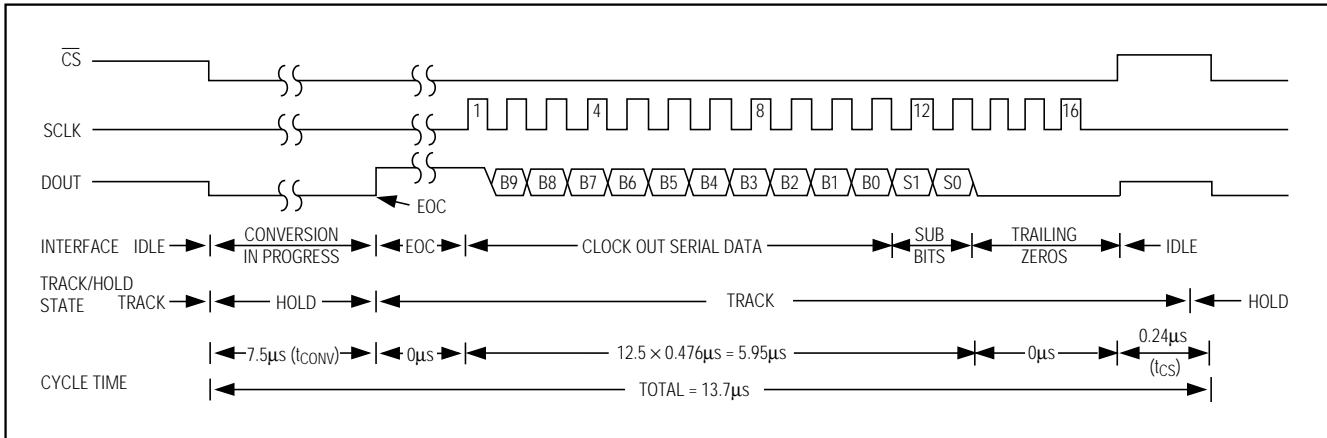

Figure 8a. Interface Timing Sequence

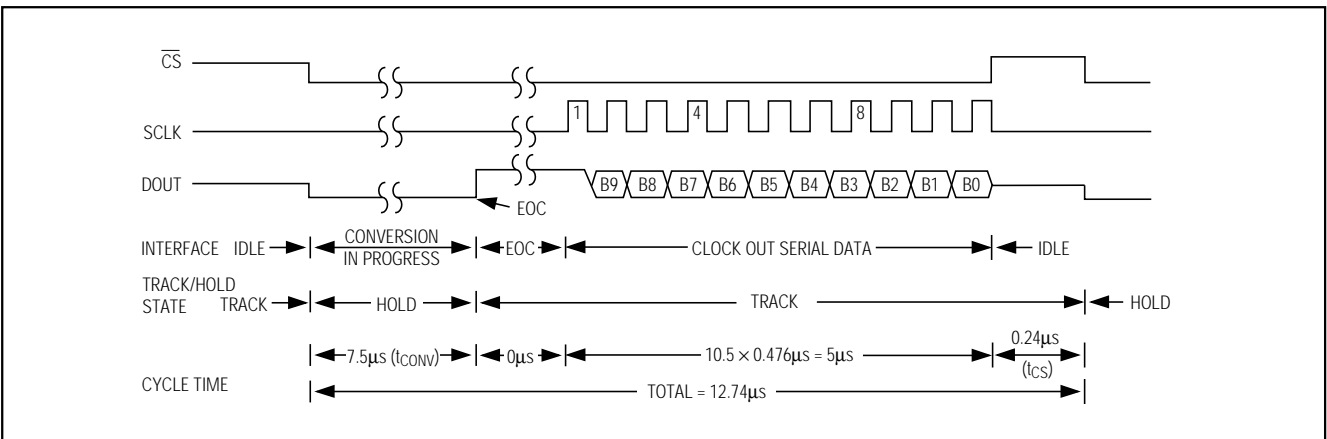

Figure 8b. Interface Timing Sequence—Minimum Cycle Time

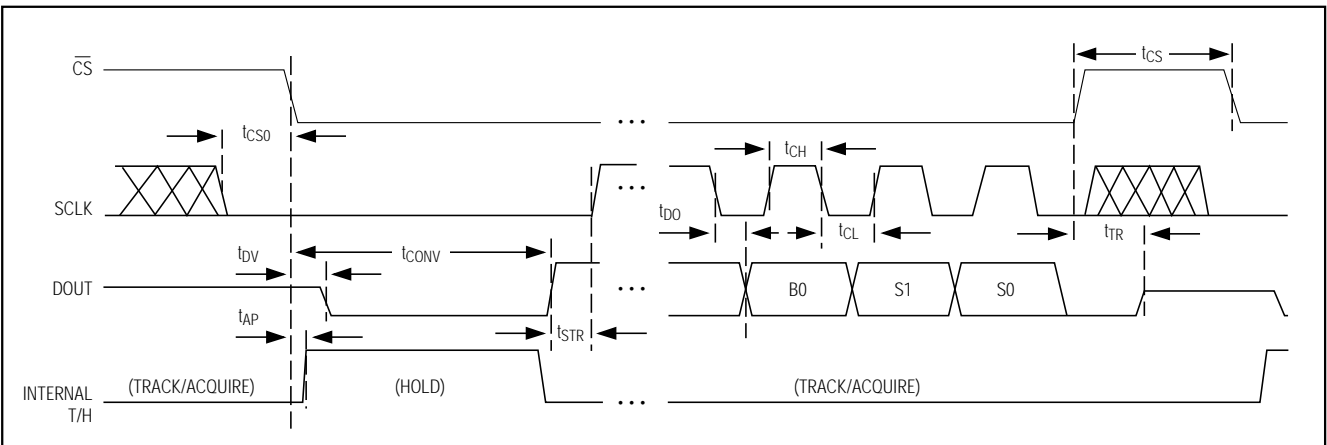

Figure 9. Detailed Serial-Interface Timing

+2.7V to +5.25V, Low-Power, 10-Bit Serial ADCs in SO-8

External Clock

The actual conversion does not require the external clock. This allows the conversion result to be read back at the μP 's convenience at any clock rate up to 2.1MHz. The clock duty cycle is unrestricted if each clock phase is at least 200ns. Do not run the clock while a conversion is in progress.

Timing and Control

Conversion-start and data-read operations are controlled by the $\overline{\text{CS}}$ and SCLK digital inputs. The timing diagrams of Figures 8 and 9 outline serial-interface operation.

A $\overline{\text{CS}}$ falling edge initiates a conversion sequence: the T/H stage holds the input voltage, the ADC begins to convert, and DOUT changes from high impedance to logic low. SCLK must be kept low during the conversion. An internal register stores the data when the conversion is in progress.

EOC is signaled by DOUT going high. DOUT's rising edge can be used as a framing signal. SCLK shifts the data out of this register any time after the conversion is complete. DOUT transitions on SCLK's falling edge. The next falling clock edge produces the MSB of the conversion at DOUT, followed by the remaining bits. Since there are 10 data bits, two sub-bits, and one leading high bit, at least 13 falling clock edges are needed to shift out these bits. Extra clock pulses occurring after the conversion result has been clocked out, and prior to a rising edge of $\overline{\text{CS}}$, produce trailing zeros at DOUT and have no effect on converter operation.

For minimum cycle time, use DOUT's rising edge as the EOC signal and then clock out the data with 10.5 clock cycles at full speed (Figure 8b). Pull $\overline{\text{CS}}$ high after reading the conversion's LSB. After the specified minimum time, t_{CS} , pull $\overline{\text{CS}}$ low again to initiate the next conversion.

Output Coding and Transfer Function

The data output from the MAX1242/MAX1243 is binary. Figure 10 depicts the nominal transfer function. Code transitions occur halfway between successive-integer LSB values. If $V_{\text{REF}} = 2.5\text{V}$, then $1\text{LSB} = 2.44\text{mV}$ or $2.5\text{V} / 1024$.

Applications Information

Connection to Standard Interfaces

The MAX1242/MAX1243 serial interface is fully compatible with SPI, QSPI, and Microwire standard serial interfaces (Figure 11).

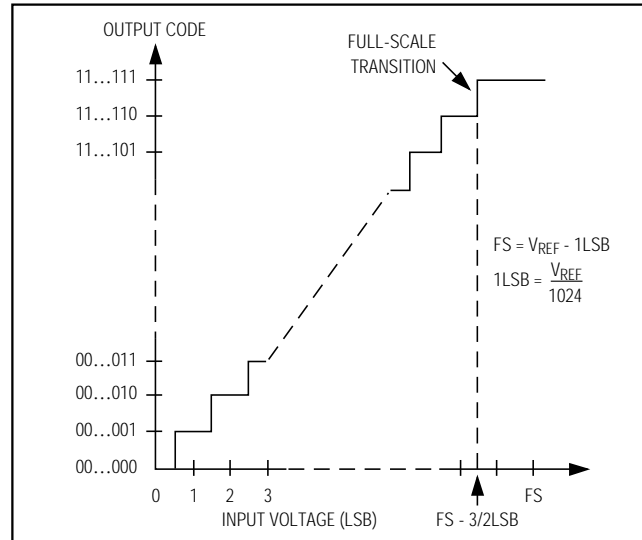

Figure 10. Unipolar Transfer Function, Full Scale (FS) = $V_{\text{REF}} - 1\text{LSB}$, Zero Scale (ZS) = GND

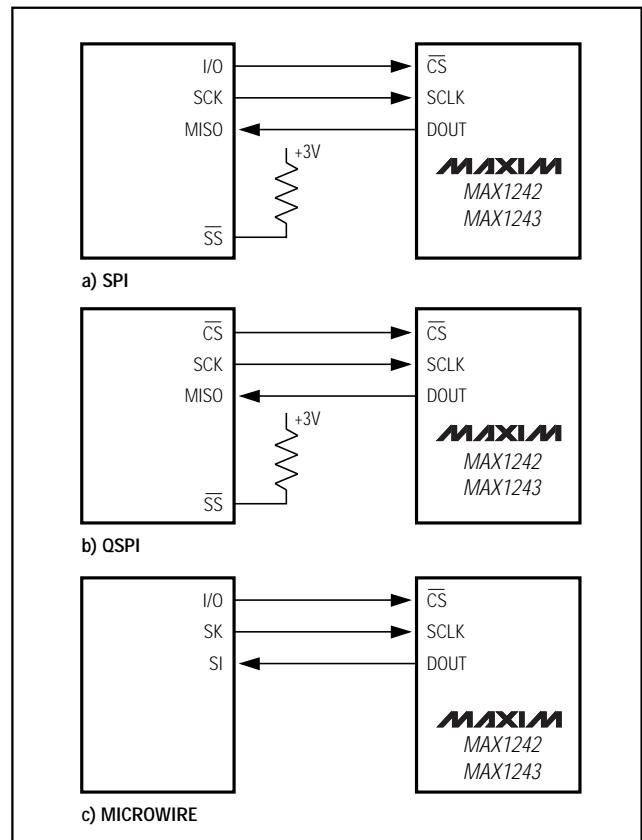

Figure 11. Common Serial-Interface Connections to the MAX1242/MAX1243

+2.7V to +5.25V, Low-Power, 10-Bit Serial ADCs in SO-8

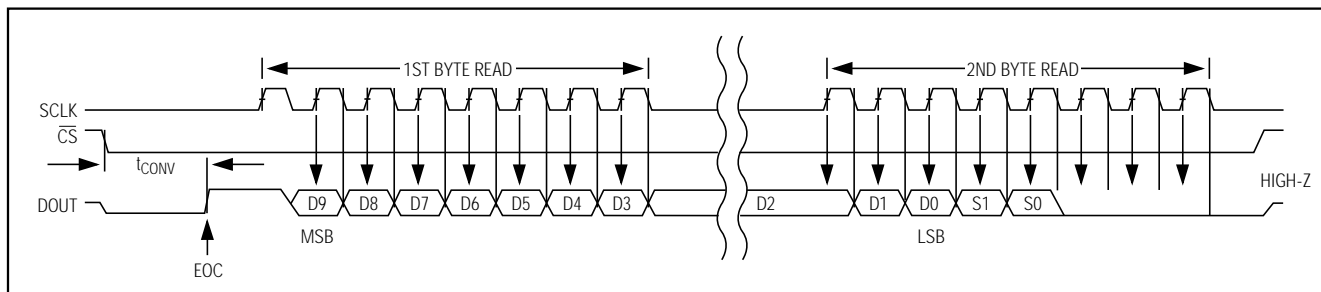

Figure 12. SPI/Microwire Serial-Interface Timing ($CPOL = CPHA = 0$)

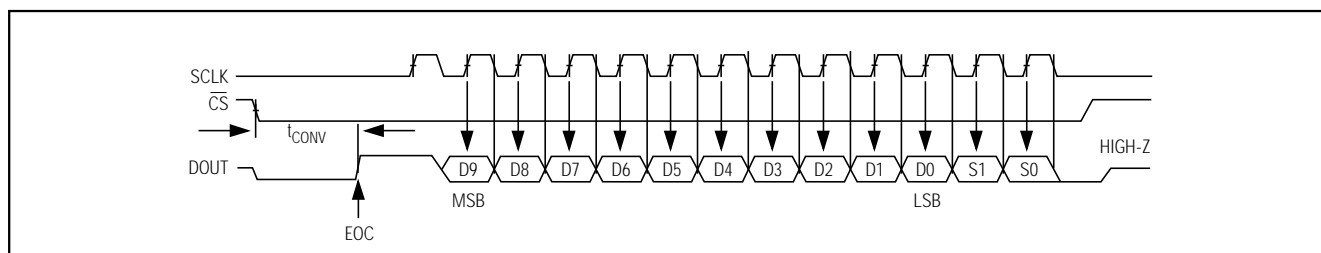

Figure 13. QSPI Serial-Interface Timing ($CPOL = CPHA = 0$)

If a serial interface is available, set the CPU's serial interface in master mode so the CPU generates the serial clock. Choose a clock frequency up to 2.1MHz.

- 1) Use a general-purpose I/O line on the CPU to pull \overline{CS} low. Keep SCLK low.
- 2) Wait the maximum conversion time specified before activating SCLK. Alternatively, look for a DOUT rising edge to determine the end of conversion.
- 3) Activate SCLK for a minimum of 11 clock cycles. The first falling clock edge produces the MSB of the DOUT conversion. DOUT output data transitions on SCLK's falling edge and is available in MSB-first format. Observe the SCLK-to-DOUT valid timing characteristic. Data can be clocked into the μP on SCLK's rising edge.
- 4) Pull \overline{CS} high at or after the 11th falling clock edge. If \overline{CS} remains low, the two sub-bits and trailing zeros are clocked out after the LSB.
- 5) With $\overline{CS} = \text{high}$, wait the minimum specified time, t_{CS} , before initiating a new conversion by pulling \overline{CS} low. If a conversion is aborted by pulling \overline{CS} high before the conversion's end, wait the minimum acquisition time, t_{ACQ} , before starting a new conversion.

Data can be output in two bytes or continuously, as shown in Figures 8a and 8b. The bytes contain the result of the conversion padded with one leading 1, two sub-bits, and trailing 0s if SCLK is still active with \overline{CS} kept low.

SPI and Microwire

When using SPI or QSPI, set $CPOL = 0$ and $CPHA = 0$. Conversion begins with a \overline{CS} falling edge. DOUT goes low, indicating a conversion is in progress. Wait until DOUT goes high or until the maximum specified 7.5 μs conversion time elapses. Two consecutive 1-byte reads are required to get the full 10+2 bits from the ADC. DOUT output data transitions on SCLK's falling edge and is clocked into the μP on SCLK's rising edge.

The first byte contains a leading 1, and seven bits of conversion result. The second byte contains the remaining three bits, two sub-bits, and three trailing zeros. See Figure 11 for connections and Figure 12 for timing.

QSPI

Set $CPOL = CPHA = 0$. Unlike SPI, which requires two 1-byte reads to acquire the 10 bits of data from the ADC, QSPI allows the minimum number of clock cycles necessary to clock in the data. The MAX1242/MAX1243 require 11 clock cycles from the μP to clock out the 10 bits of data. Additional clock cycles clock out the two sub-bits followed by trailing zeros (Figure 13). The maximum clock frequency to ensure compatibility with QSPI is 2.097MHz.

Layout and Grounding

For best performance, use printed circuit boards. Wire-wrap boards are not recommended. Board layout should ensure that digital and analog signal lines are separated from each other. Do not run analog and digital (especially clock) lines parallel to one another, or digital lines underneath the ADC package.

+2.7V to +5.25V, Low-Power, 10-Bit Serial ADCs in SO-8

Ordering Information (continued)

PART	TEMP. RANGE	PIN-PACKAGE	INL (LSB)
MAX1242AESA	-40°C to +85°C	8 SO	±1/2
MAX1242BESA	-40°C to +85°C	8 SO	±1
MAX1242AMJA	-55°C to +125°C	8 CERDIP*	±1/2
MAX1242BMJA	-55°C to +125°C	8 CERDIP*	±1
MAX1243 ACPA	0°C to +70°C	8 Plastic DIP	±1/2
MAX1243BCPA	0°C to +70°C	8 Plastic DIP	±1
MAX1243ACSA	0°C to +70°C	8 SO	±1/2
MAX1243BCSA	0°C to +70°C	8 SO	±1
MAX1243AEPA	-40°C to +85°C	8 Plastic DIP	±1/2
MAX1243BEPA	-40°C to +85°C	8 Plastic DIP	±1
MAX1243AESA	-40°C to +85°C	8 SO	±1/2
MAX1243BESA	-40°C to +85°C	8 SO	±1
MAX1243AMJA	-55°C to +125°C	8 CERDIP*	±1/2
MAX1243BMJA	-55°C to +125°C	8 CERDIP*	±1

* Contact factory for availability and processing to MIL-STD-883.

Note: Order the MAX1242A in place of the MAX1242C. Order the MAX1242B in place of the MAX1242D.

Chip Information

TRANSISTOR COUNT: 2559
SUBSTRATE CONNECTED TO GND

Package Information

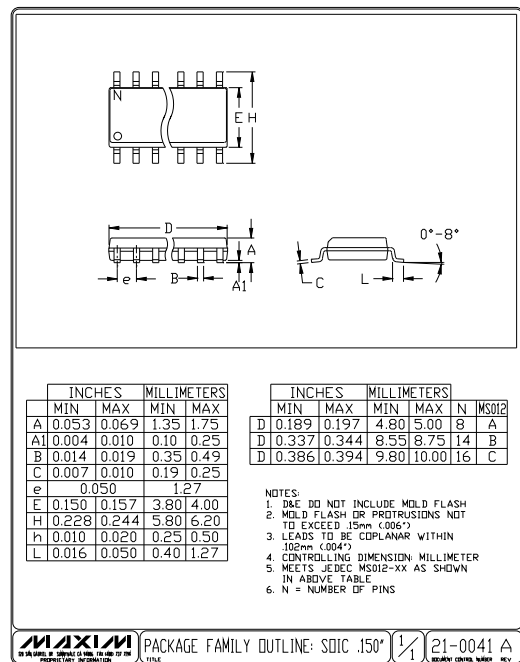
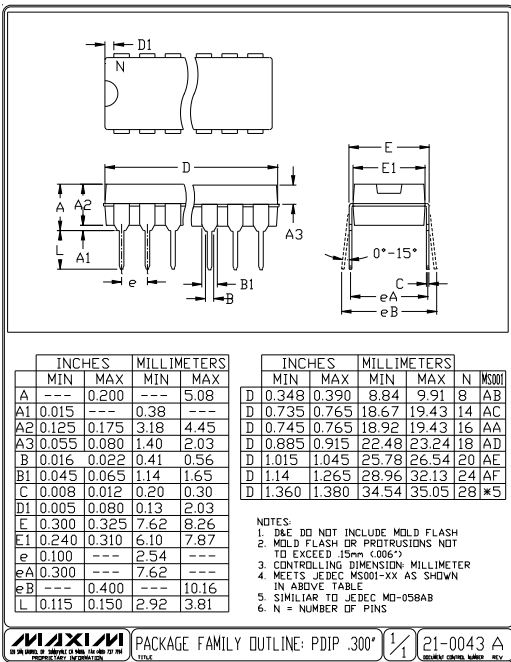

Maxim cannot assume responsibility for use of any circuitry other than circuitry entirely embodied in a Maxim product. No circuit patent licenses are implied. Maxim reserves the right to change the circuitry and specifications without notice at any time.

12 Maxim Integrated Products, 120 San Gabriel Drive, Sunnyvale, CA 94086 408-737-7600

© 1998 Maxim Integrated Products

Printed USA

MAXIM is a registered trademark of Maxim Integrated Products.