

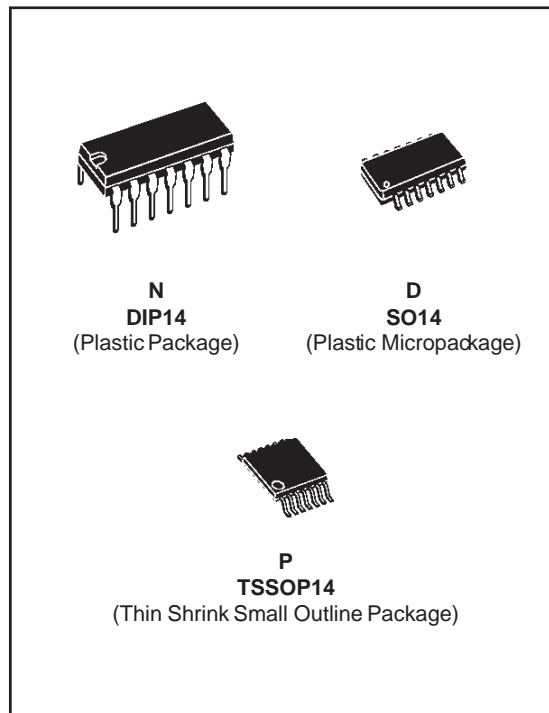

# LM2901

## LOW POWER QUAD VOLTAGE COMPARATORS

- WIDE SINGLE SUPPLY VOLTAGE RANGE OR DUAL SUPPLIES FOR ALL DEVICES : +2V TO +36V OR  $\pm 1V$  TO  $\pm 18V$
- VERY LOW SUPPLY CURRENT (1.1mA) INDEPENDENT OF SUPPLY VOLTAGE (1.4mW/comparator at +5V)
- LOW INPUT BIAS CURRENT : 25nA TYP
- LOW INPUT OFFSET CURRENT :  $\pm 5nA$  TYP
- INPUT COMMON-MODE VOLTAGE RANGE INCLUDES GROUND
- LOW OUTPUT SATURATION VOLTAGE : 250mV TYP. ( $I_O = 4mA$ )
- DIFFERENTIAL INPUT VOLTAGE RANGE EQUAL TO THE SUPPLY VOLTAGE
- TTL, DTL, ECL, MOS, CMOS COMPATIBLE OUTPUTS



### DESCRIPTION

This device consists of four independent precision voltage comparators. All these comparators were designed specifically to operate from a single power supply over a wide range of voltages. Operation from split power supplies is also possible.

These comparators also have a unique characteristic in that the input common-mode voltage range includes ground even though operated from a single power supply voltage.

### ORDER CODES

Part Number	Temperature Range	Package		
		N	D	P
LM2901	-40, +125°C	•	•	•
<b>Example :</b> LM2901D				

### PIN CONNECTIONS (top view)

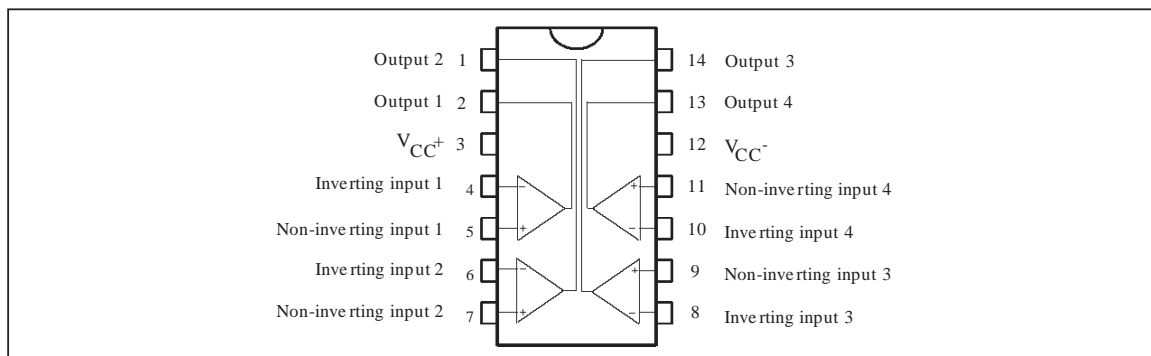

**SCHEMATIC DIAGRAM (1/4 LM2901)**

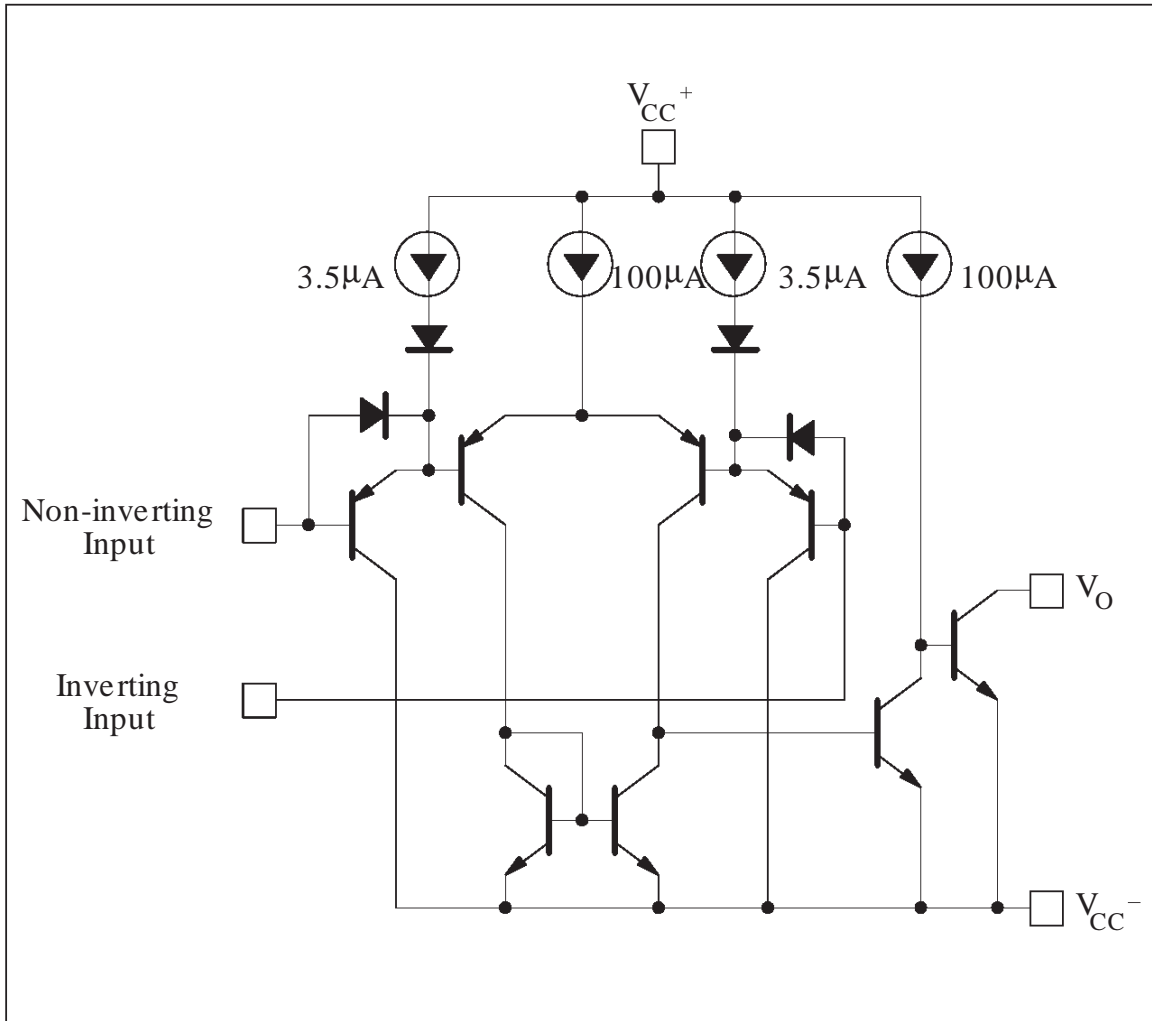

**ABSOLUTE MAXIMUM RATINGS**

Symbol	Parameter	LM2901	Unit
V <sub>CC</sub>	Supply Voltage	±18 to 36	V
V <sub>id</sub>	Differential Input Voltage	±36	V
V <sub>I</sub>	Input Voltage	-0.3 to +36	V
	Output Short-circuit to Ground - note 1		
P <sub>tot</sub>	Power Dissipation	570	mW
T <sub>oper</sub>	Operating Free-air Temperature Range	-40, +125	°C
T <sub>stg</sub>	Storage Temperature Range	-65, +150	°C

**Notes :** 1. Short-circuit from the output to V<sub>CC</sub><sup>+</sup> can cause excessive heating and eventual destruction. The maximum output current is approximately 20mA, independent of the magnitude of V<sub>CC</sub><sup>+</sup>.

**ELECTRICAL CHARACTERISTICS**
 $V_{CC}^+ = +5V$ ,  $V_{CC}^- = GND$ ,  $T_{amb} = 25^{\circ}C$  (unless otherwise specified)

Symbol	Parameter	Min.	Typ.	Max.	Unit
$V_{io}$	Input Offset Voltage - note 2 $T_{amb} = +25^{\circ}C$ $T_{min.} \leq T_{amb} \leq T_{max.}$		1	7 15	mV
$I_{io}$	Input Offset Current $T_{amb} = +25^{\circ}C$ $T_{min.} \leq T_{amb} \leq T_{max.}$		5	50 150	nA
$I_{ib}$	Input Bias Current ( $I_{i^+}$ or $I_{i^-}$ ) - note 3 $T_{amb} = +25^{\circ}C$ $T_{min.} \leq T_{amb} \leq T_{max.}$		25	250 400	nA
$A_{vd}$	Large Signal Voltage Gain ( $V_{CC} = 15V$ , $R_L = 15k\Omega$ , $V_O = 1$ to $11V$ )	25	200		V/mV
$I_{CC}$	Supply Current (all comparators) $V_{CC} = +5V$ , no load $V_{CC} = +30V$ , no load		1.1 1.3	2 2.5	mA
$V_{icm}$	Input Common Mode Voltage Range ( $V_{CC} = 30V$ ) - note 4 $T_{amb} = +25^{\circ}C$ $T_{min.} \leq T_{amb} \leq T_{max.}$	0 0		$V_{CC}^+ - 1.5$ $V_{CC}^+ - 2$	V
$V_{id}$	Differential Input Voltage - note 6			$V_{CC}^+$	V
$V_{OL}$	Low Level Output Voltage ( $V_{id} = -1V$ , $I_{sink} = 4mA$ ) $T_{amb} = +25^{\circ}C$ $T_{min.} \leq T_{amb} \leq T_{max.}$		250	400 700	mV
$I_{OH}$	High Level Output Current ( $V_{CC} = V_O = 30V$ , $V_{id} = 1V$ ) $T_{amb} = +25^{\circ}C$ $T_{min.} \leq T_{amb} \leq T_{max.}$		0.1	1	nA $\mu A$
$I_{sink}$	Output Sink Current ( $V_{id} = -1V$ , $V_O = 1.5V$ )	6	16		mA
$t_{re}$	Small Signal Response Time - (note 5) ( $R_L = 5.1k\Omega$ connected to $V_{CC}^+$ )		1.3		$\mu s$
$t_{rel}$	Large Signal Response Time - (note 7) TTL Input ( $V_{ref} = +1.4V$ , $R_L = 5.1k\Omega$ to $V_{CC}^+$ ) Output Signal at 50% of final value Output Signal at 95% of final value			500 1	ns $\mu s$

- Notes :**
- At output switch point,  $V_O \approx 1.4V$ ,  $R_S = 0$  with  $V_{CC}^+$  from 5V to 30V, and over the full input common-mode range (0V to  $V_{CC}^+ - 1.5V$ ).
  - The direction of the input current is out of the IC due to the PNP input stage. This current is essentially constant, independent of the state of the output, so no loading charge exists on the reference of input lines.
  - The input common-mode voltage of either input signal voltage should not be allowed to go negative by more than 0.3V. The upper end of the common-mode voltage range is  $V_{CC}^+ - 1.5V$ , but either or both inputs can go to +30V without damage.
  - The response time specified is for a 100mV input step with 5mV overdrive.
  - Positive excursions of input voltage may exceed the power supply level. As long as the other voltage remains within the common-mode range, the comparator will provide a proper output state. The low input voltage state must not be less than -0.3V (or 0.3V below the negative power supply, if used).
  - Maximum values are guaranteed by design.

SUPPLY CURRENT versus SUPPLY VOLTAGE

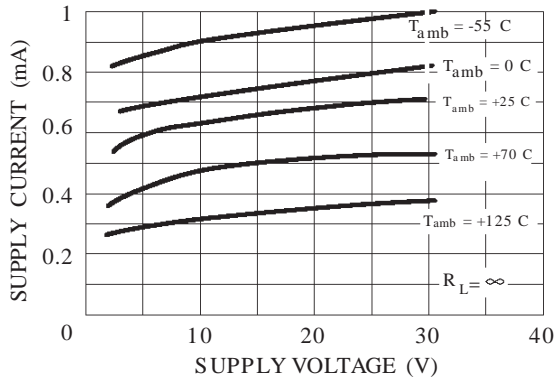

INPUT CURRENT versus SUPPLY VOLTAGE

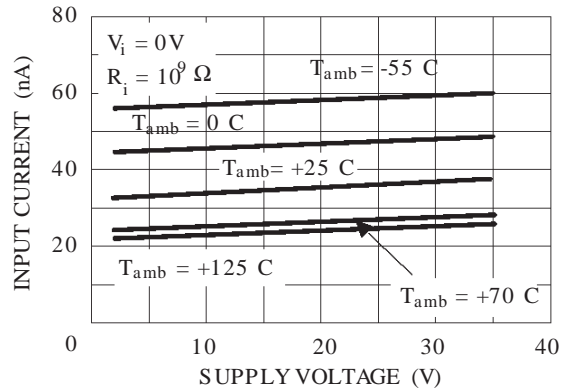

OUTPUT SATURATION VOLTAGE versus OUTPUT CURRENT

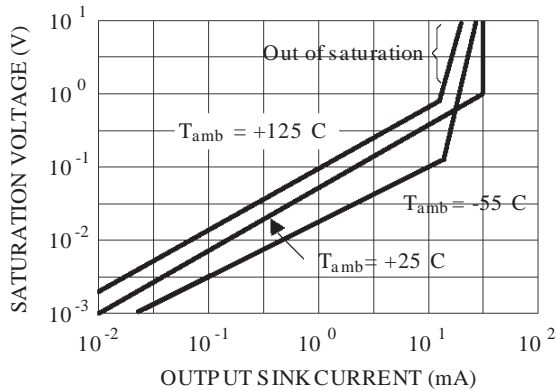

RESPONSE TIME FOR VARIOUS INPUT OVERDRIVES - NEGATIVE TRANSITION

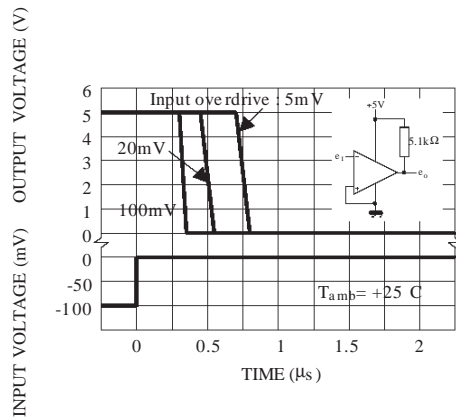

RESPONSE TIME FOR VARIOUS INPUT OVERDRIVES - POSITIVE TRANSITION

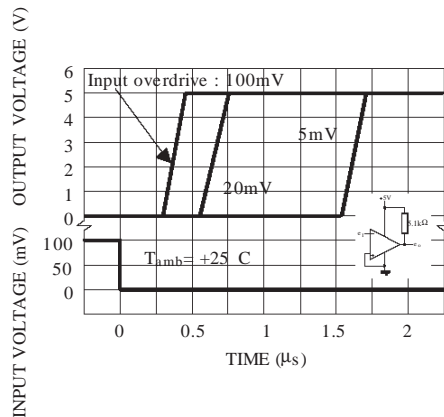

TYPICAL APPLICATIONS

BASIC COMPARATOR

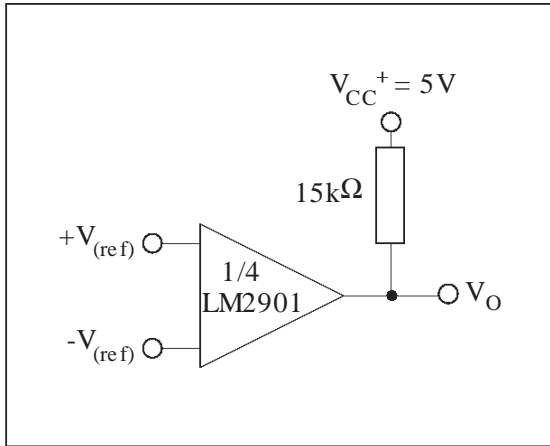

DRIVING CMOS

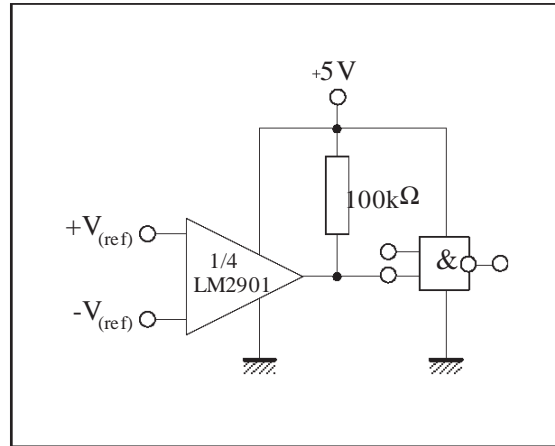

DRIVING TTL

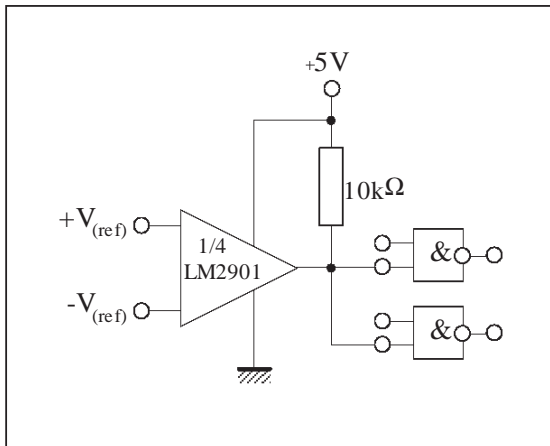

LOW FREQUENCY OP AMP

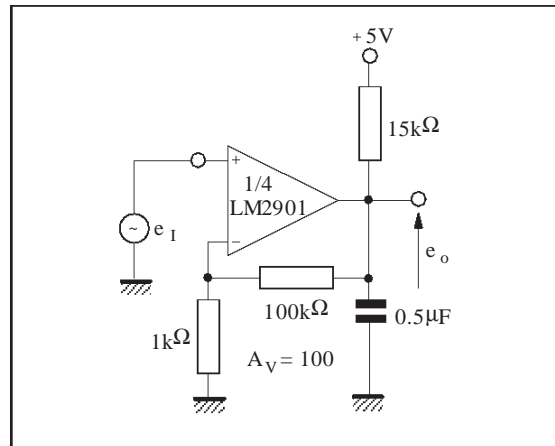

LOW FREQUENCY OP AMP

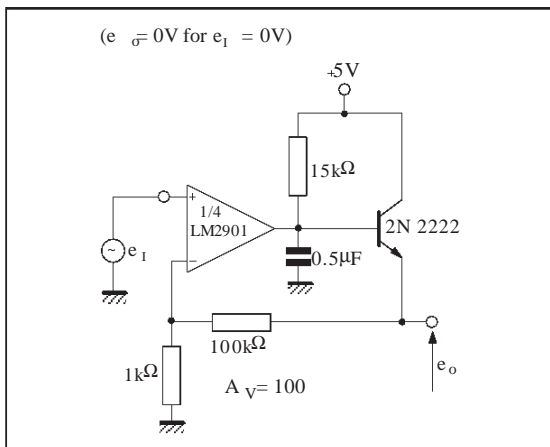

TRANSDUCER AMPLIFIER

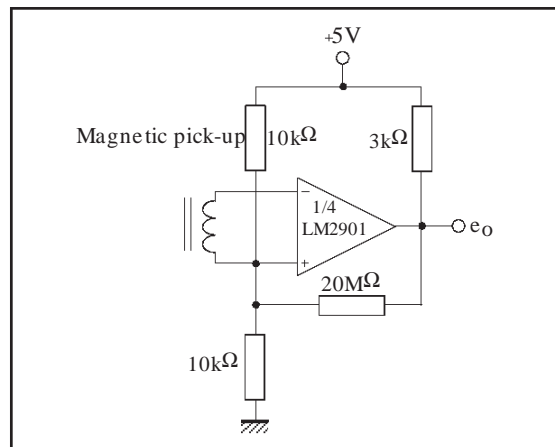

TYPICAL APPLICATIONS (continued)

TIME DELAY GENERATOR

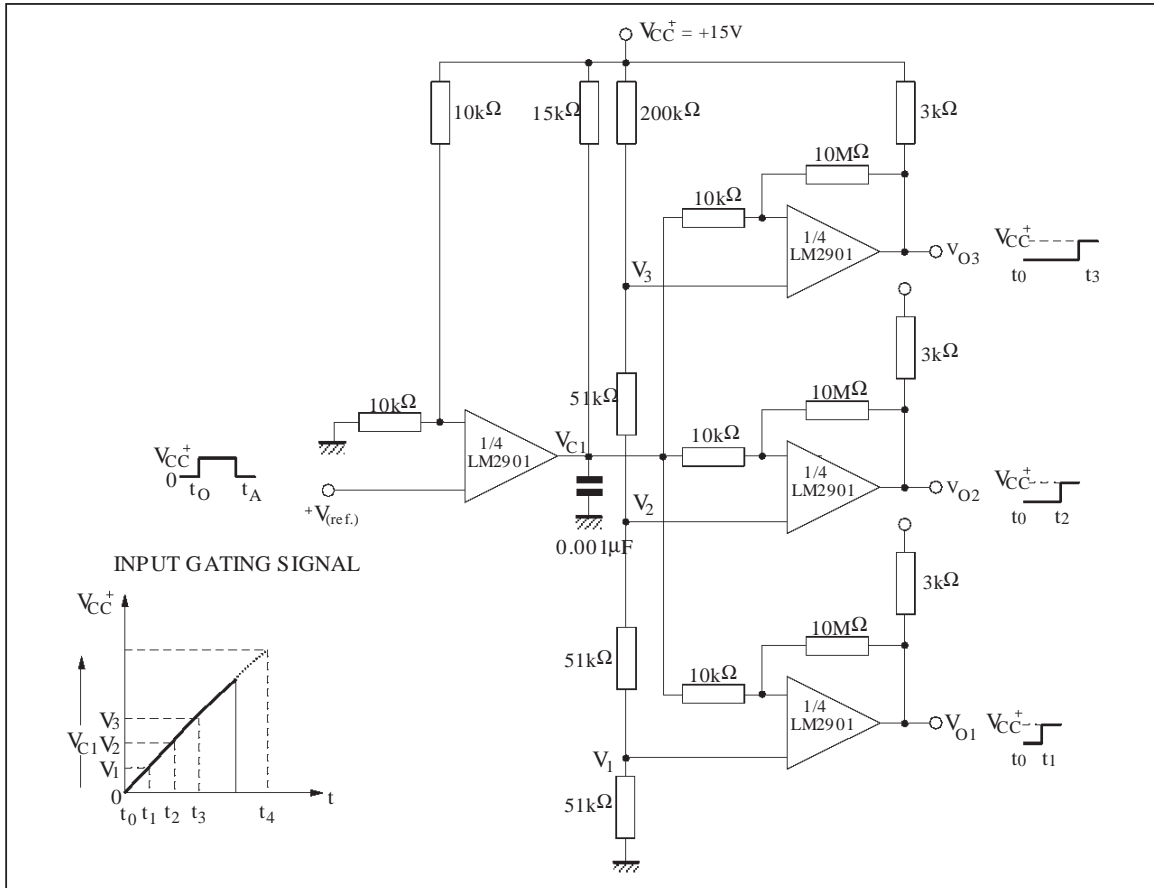

LOW FREQUENCY OP AMP WITH OFFSET ADJUST

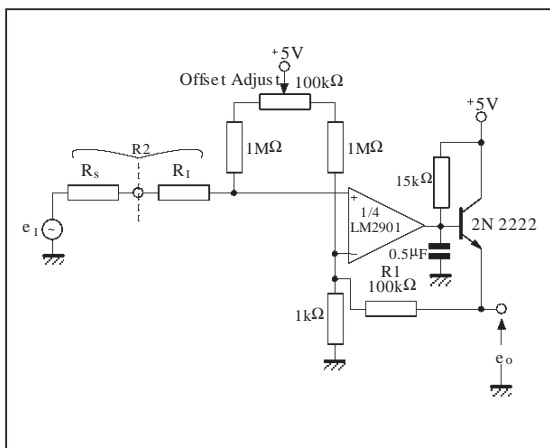

ZERO CROSSING DETECTOR (single power supply)

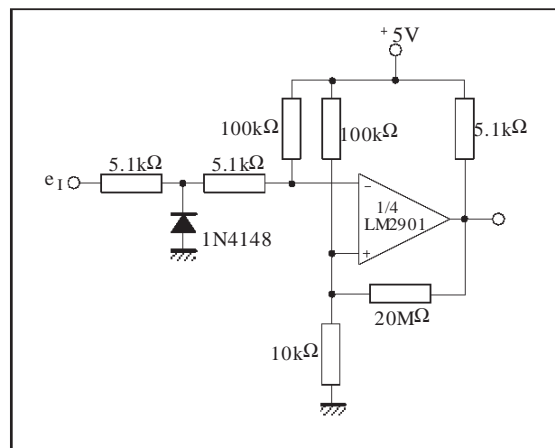

**TYPICAL APPLICATIONS** (continued)

**TWO-DECADE HIGH-FREQUENCY VCO**

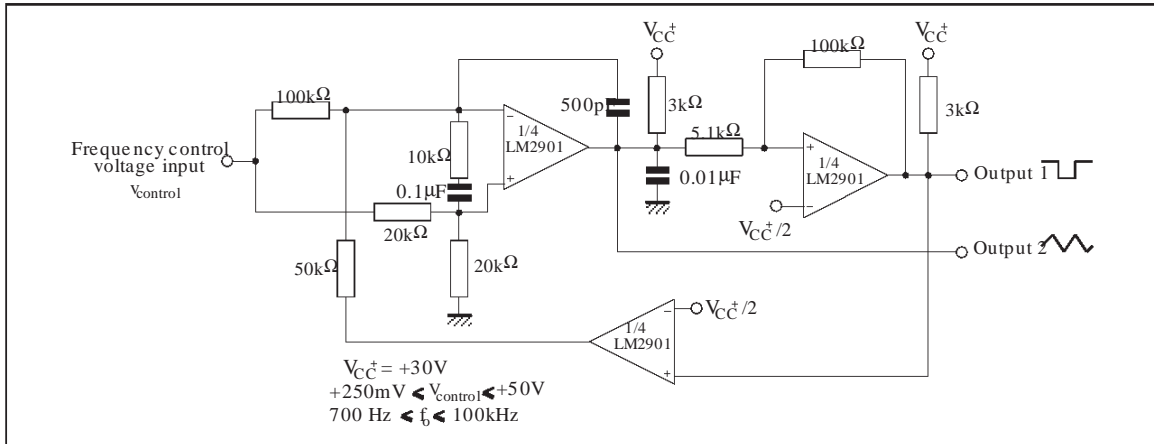

**LIMIT COMPARATOR**

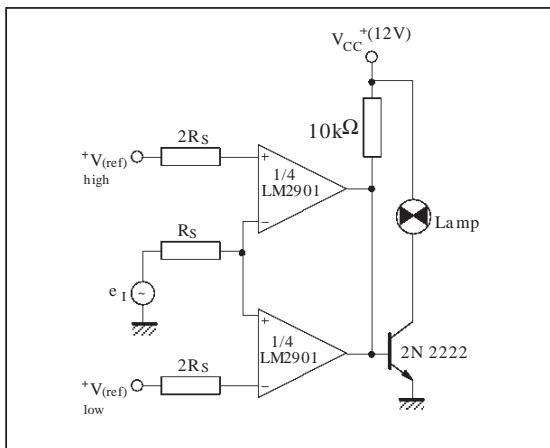

**CRYSTAL CONTROLLED OSCILLATOR**

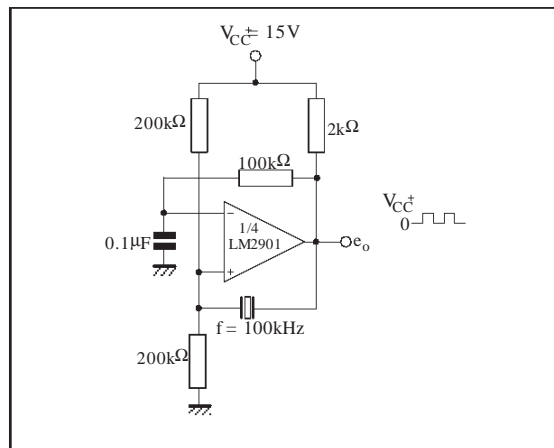

**SPLIT-SUPPLY APPLICATIONS**

**ZERO CROSSING DETECTOR**

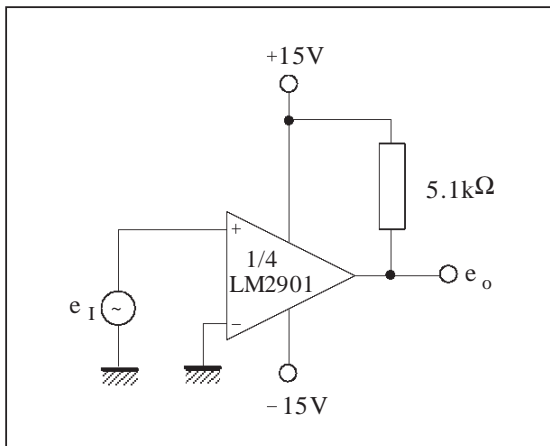

**COMPARATOR WITH A NEGATIVE REFERENCE**

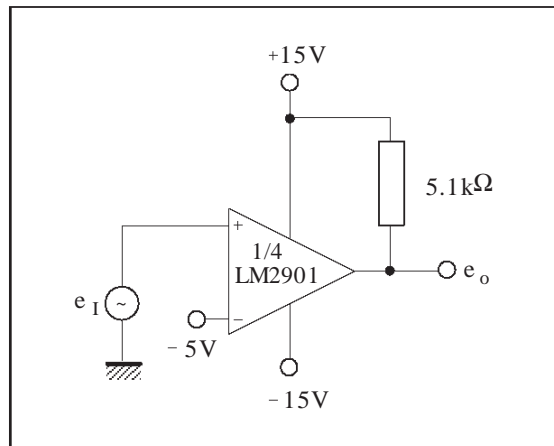

# LM2901

## PACKAGE MECHANICAL DATA 14 PINS - PLASTIC DIP

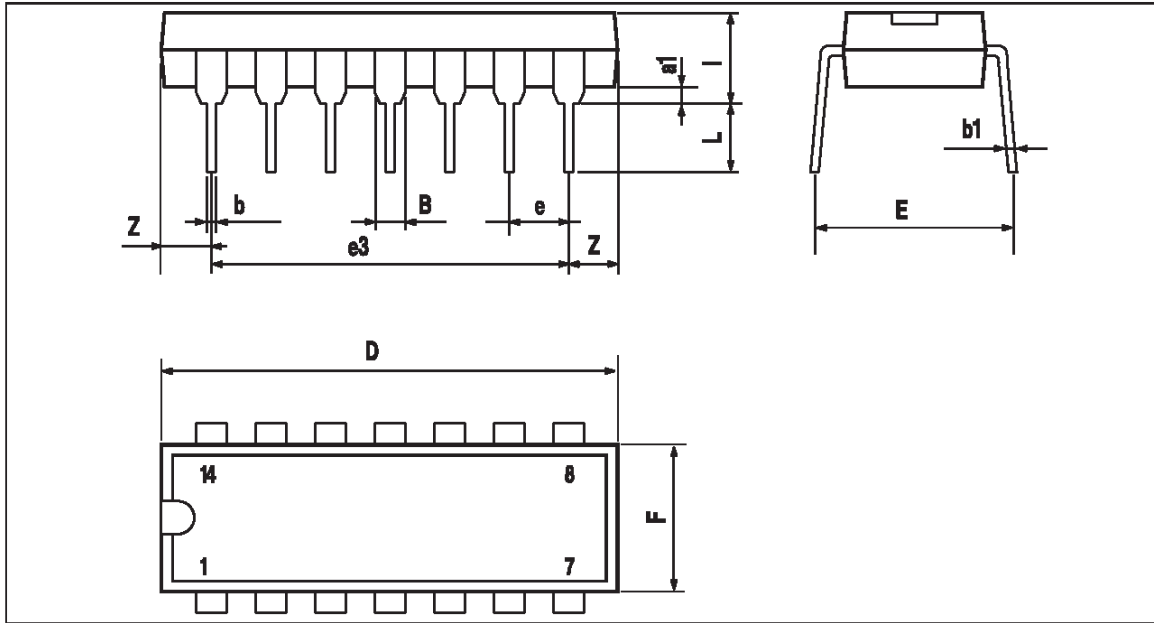

PM-DIP14.EPS

Dimensions	Millimeters			Inches		
	Min.	Typ.	Max.	Min.	Typ.	Max.
$a_1$	0.51			0.020		
$B$	1.39		1.65	0.055		0.065
$b$		0.5			0.020	
$b_1$		0.25			0.010	
$D$			20			0.787
$E$		8.5			0.335	
$e$		2.54			0.100	
$e_3$		15.24			0.600	
$F$			7.1			0.280
$i$			5.1			0.201
$L$		3.3			0.130	
$Z$	1.27		2.54	0.050		0.100

DIP14.TBL



**PACKAGE MECHANICAL DATA**  
14 PINS - PLASTIC MICROPACKAGE (SO)

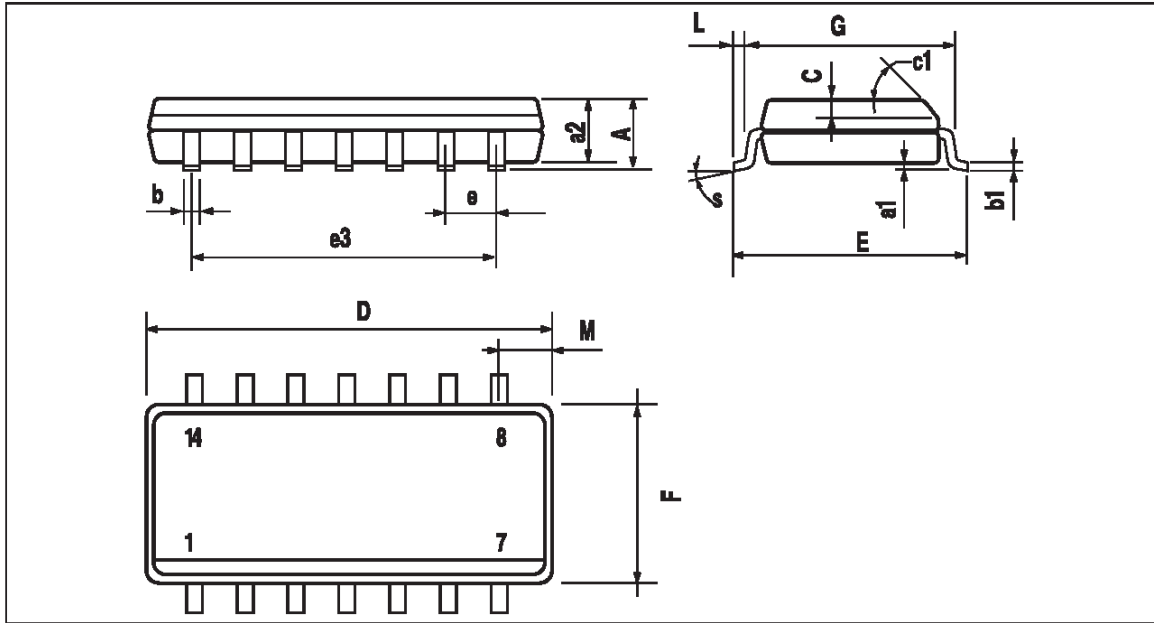

PM-SO14.EP

Dim.	Millimeters			Inches		
	Min.	Typ.	Max.	Min.	Typ.	Max.
A			1.75			0.069
a1	0.1		0.2	0.004		0.008
a2			1.6			0.063
b	0.35		0.46	0.014		0.018
b1	0.19		0.25	0.007		0.010
C		0.5			0.020	
c1	45° (typ.)					
D	8.55		8.75	0.336		0.334
E	5.8		6.2	0.228		0.244
e		1.27			0.050	
e3		7.62			0.300	
F	3.8		4.0	0.150		0.157
G	4.6		5.3	0.181		0.208
L	0.5		1.27	0.020		0.050
M			0.68			0.027
S	8° (max.)					

SO14.TBL

# LM2901

## PACKAGE MECHANICAL DATA 14 PINS - THIN SHRINK SMALL OUTLINE PACKAGE

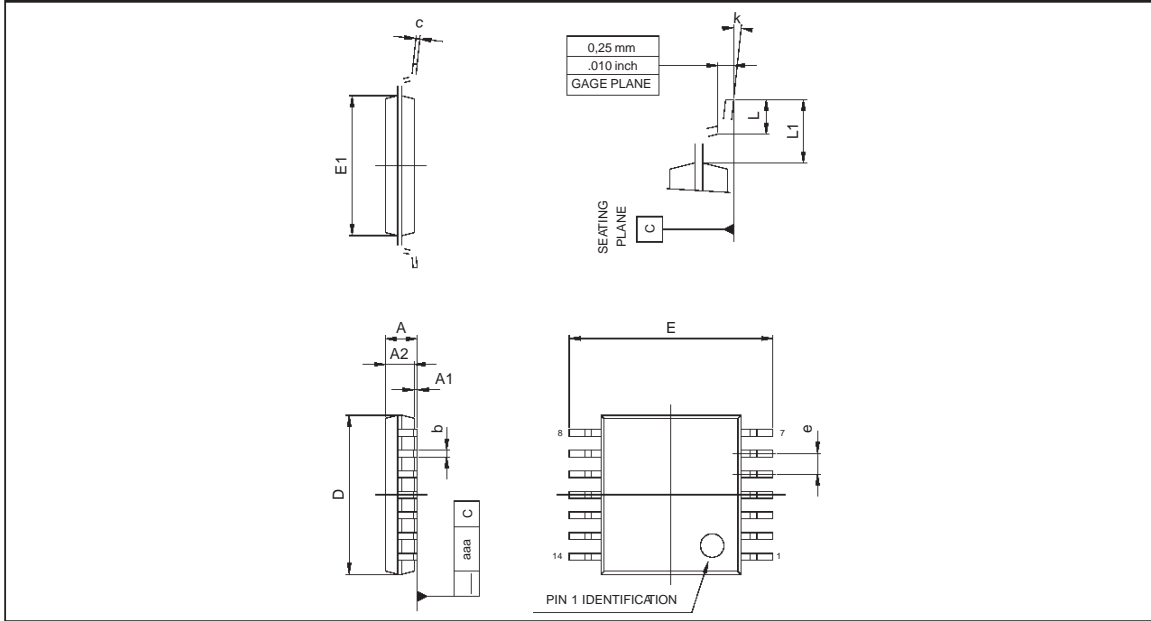

Dim.	Millimeters			Inches		
	Min.	Typ.	Max.	Min.	Typ.	Max.
A			1.20			0.05
A1	0.05		0.15	0.01		0.006
A2	0.80	1.00	1.05	0.031	0.039	0.041
b	0.19		0.30	0.007		0.15
c	0.09		0.20	0.003		0.012
D	4.90	5.00	5.10	0.192	0.196	0.20
E		6.40			0.252	
E1	4.30	4.40	4.50	0.169	0.173	0.177
e		0.65			0.025	
k	0°		8°	0°		8°
l	0.50	0.60	0.75	0.09	0.0236	0.030

Information furnished is believed to be accurate and reliable. However, STMicroelectronics assumes no responsibility for the consequences of use of such information nor for any infringement of patents or other rights of third parties which may result from its use. No license is granted by implication or otherwise under any patent or patent rights of STMicroelectronics. Specifications mentioned in this publication are subject to change without notice. This publication supersedes and replaces all information previously supplied. STMicroelectronics products are not authorized for use as critical components in life support devices or systems without express written approval of STMicroelectronics.

© The ST logo is a trademark of STMicroelectronics

© 1999 STMicroelectronics – Printed in Italy – All Rights Reserved

STMicroelectronics GROUP OF COMPANIES

Australia - Brazil - China - Finland - France - Germany - Hong Kong - India - Italy - Japan - Malaysia - Malta - Morocco  
Singapore - Spain - Sweden - Switzerland - United Kingdom - U.S.A.

© <http://www.st.com>

ORDER CODE :