

LM3915

Dot/Bar Display Driver

General Description

The LM3915 is a monolithic integrated circuit that senses analog voltage levels and drives ten LEDs, LCDs or vacuum fluorescent displays, providing a logarithmic 3 dB/step analog display. One pin changes the display from a bar graph to a moving dot display. LED current drive is regulated and programmable, eliminating the need for current limiting resistors. The whole display system can operate from a single supply as low as 3V or as high as 25V.

The IC contains an adjustable voltage reference and an accurate ten-step voltage divider. The high-impedance input buffer accepts signals down to ground and up to within 1.5V of the positive supply. Further, it needs no protection against inputs of $\pm 35V$. The input buffer drives 10 individual comparators referenced to the precision divider. Accuracy is typically better than 1 dB.

The LM3915's 3 dB/step display is suited for signals with wide dynamic range, such as audio level, power, light intensity or vibration. Audio applications include average or peak level indicators, power meters and RF signal strength meters. Replacing conventional meters with an LED bar graph results in a faster responding, more rugged display with high visibility that retains the ease of interpretation of an analog display.

The LM3915 is extremely easy to apply. A 1.2V full-scale meter requires only one resistor in addition to the ten LEDs. One more resistor programs the full-scale anywhere from 1.2V to 12V independent of supply voltage. LED brightness is easily controlled with a single pot.

The LM3915 is very versatile. The outputs can drive LCDs, vacuum fluorescents and incandescent bulbs as well as LEDs of any color. Multiple devices can be cascaded for a dot or bar mode display with a range of 60 or 90 dB. LM3915s can also be cascaded with LM3914s for a linear/log display or with LM3916s for an extended-range VU meter.

Features

- 3 dB/step, 30 dB range
- Drives LEDs, LCDs, or vacuum fluorescents
- Bar or dot display mode externally selectable by user
- Expandable to displays of 90 dB
- Internal voltage reference from 1.2V to 12V
- Operates with single supply of 3V to 25V
- Inputs operate down to ground
- Output current programmable from 1 mA to 30 mA
- Input withstands $\pm 35V$ without damage or false outputs
- Outputs are current regulated, open collectors
- Directly drives TTL or CMOS
- The internal 10-step divider is floating and can be referenced to a wide range of voltages

The LM3915 is rated for operation from 0°C to +70°C. The LM3915N-1 is available in an 18-lead molded DIP package.

Typical Applications

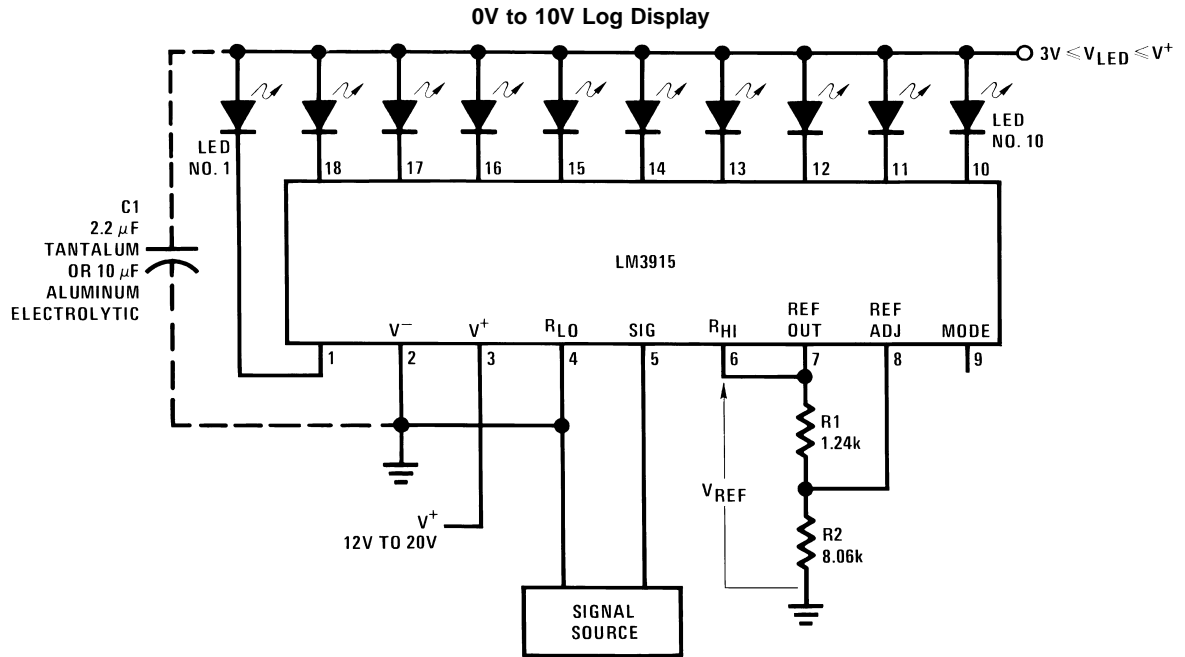

DS005104-1

Notes: Capacitor C1 is required if leads to the LED supply are 6" or longer.

Circuit as shown is wired for dot mode. For bar mode, connect pin 9 to pin 3. V_{LED} must be kept below 7V or dropping resistor should be used to limit IC power dissipation.

$$V_{REF} = 1.25V \left(1 + \frac{R_2}{R_1} \right) + R_2 \times 80 \mu A$$

$$I_{LED} = \frac{12.5V}{R_1} + \frac{V_{REF}}{2.2 k\Omega}$$

Absolute Maximum Ratings (Note 1)

If Military/Aerospace specified devices are required, please contact the National Semiconductor Sales Office/Distributors for availability and specifications.

Power Dissipation (Note 6)
Molded DIP(N)

1365 mW

Supply Voltage

25V

Voltage on Output Drivers

25V

Input Signal Overvoltage (Note 4)

±35V

Divider Voltage

-100 mV to V⁺

Reference Load Current

10 mA

Storage Temperature Range

-55°C to +150°C

Lead Temperature

(Soldering, 10 sec.)

260°C

Electrical Characteristics (Notes 2, 4)

Parameter	Conditions (Note 2)	Min	Typ	Max	Units
COMPARATOR					
Offset Voltage, Buffer and First Comparator	$0V \leq V_{RLO} = V_{RHI} \leq 12V$, $I_{LED} = 1 \text{ mA}$		3	10	mV
Offset Voltage, Buffer and Any Other Comparator	$0V \leq V_{RLO} = V_{RHI} \leq 12V$, $I_{LED} = 1 \text{ mA}$		3	15	mV
Gain ($\Delta I_{LED}/\Delta V_{IN}$)	$I_{L(REF)} = 2 \text{ mA}$, $I_{LED} = 10 \text{ mA}$	3	8		mA/mV
Input Bias Current (at Pin 5)	$0V \leq V_{IN} \leq (V^+ - 1.5V)$		25	100	nA
Input Signal Overvoltage	No Change in Display	-35		35	V
VOLTAGE-DIVIDER					
Divider Resistance	Total, Pin 6 to 4	16	28	36	kΩ
Relative Accuracy (Input Change Between Any Two Threshold Points)	(Note 3)	2.0	3.0	4.0	dB
Absolute Accuracy at Each Threshold Point	(Note 3)				
	$V_{IN} = -3, -6 \text{ dB}$	-0.5		+0.5	dB
	$V_{IN} = -9 \text{ dB}$	-0.5		+0.65	dB
	$V_{IN} = -12, -15, -18 \text{ dB}$	-0.5		+1.0	dB
	$V_{IH} = -21, -24, -27 \text{ dB}$	-0.5		+1.5	dB
VOLTAGE REFERENCE					
Output Voltage	$0.1 \text{ mA} \leq I_{L(REF)} \leq 4 \text{ mA}$, $V^+ = V_{LED} = 5V$	1.2	1.28	1.34	V
Line Regulation	$3V \leq V^+ \leq 18V$		0.01	0.03	%/V
Load Regulation	$0.1 \text{ mA} \leq I_{L(REF)} \leq 4 \text{ mA}$, $V^+ = V_{LED} = 5V$		0.4	2	%
Output Voltage Change with Temperature	$0^\circ\text{C} \leq T_A \leq +70^\circ\text{C}$, $I_{L(REF)} = 1 \text{ mA}$, $V^+ = V_{LED} = 5V$		1		%
Adjust Pin Current			75	120	μA
OUTPUT DRIVERS					
LED Current	$V^+ = V_{LED} = 5V$, $I_{L(REF)} = 1 \text{ mA}$	7	10	13	mA
LED Current Difference (Between Largest and Smallest LED Currents)	$V_{LED} = 5V$, $I_{LED} = 2 \text{ mA}$ $V_{LED} = 5V$, $I_{LED} = 20 \text{ mA}$		0.12	0.4	mA
			1.2	3	
LED Current Regulation	$2V \leq V_{LED} \leq 17V$, $I_{LED} = 2 \text{ mA}$ $I_{LED} = 20 \text{ mA}$		0.1	0.25	mA
			1	3	
Dropout Voltage	$I_{LED(ON)} = 20 \text{ mA}$, @ $V_{LED} = 5V$, $\Delta I_{LED} = 2 \text{ mA}$			1.5	V
Saturation Voltage	$I_{LED} = 2.0 \text{ mA}$, $I_{L(REF)} = 0.4 \text{ mA}$		0.15	0.4	V
Output Leakage, Each Collector	(Bar Mode) (Note 5)		0.1	10	μA
Output Leakage Pins 10–18 Pin 1	(Dot Mode) (Note 5)		0.1	10	μA
		60	150	450	μA
SUPPLY CURRENT					
Standby Supply Current (All Outputs Off)	$V^+ = +5V$, $I_{L(REF)} = 0.2 \text{ mA}$ $V^+ = +20V$, $I_{L(REF)} = 1.0 \text{ mA}$		2.4	4.2	mA
			6.1	9.2	mA

Electrical Characteristics (Notes 2, 4) (Continued)

Note 1: Absolute Maximum Ratings indicate limits beyond which damage to the device may occur. Operating Ratings indicate conditions for which the device is functional, but do not guarantee specific performance limits. Electrical Characteristics state DC and AC electrical specifications under particular test conditions which guarantee specific performance limits. This assumes that the device is within the Operating Ratings. Specifications are not guaranteed for parameters where no limit is given, however, the typical value is a good indication of device performance.

Note 2: Unless otherwise stated, all specifications apply with the following conditions:

$$3 V_{DC} \leq V^+ \leq 20 V_{DC} \quad -0.015V \leq V_{RLO} \leq 12 V_{DC} \quad T_A = 25^\circ\text{C}, I_{L(\text{REF})} = 0.2 \text{ mA, pin 9 connected to pin 3 (bar mode).}$$

$$3 V_{DC} \leq V_{LED} \leq V^+ \quad V_{REF}, V_{RHI}, V_{RLO} \leq (V^+ - 1.5V) \quad \text{For higher power dissipations, pulse testing is used.}$$

$$-0.015V \leq V_{RHI} \leq 12 V_{DC} \quad 0V \leq V_{IN} \leq V^+ - 1.5V$$

Note 3: Accuracy is measured referred to 0 dB = + 10.000 V_{DC} at pin 5, with + 10.000 V_{DC} at pin 6, and 0.000 V_{DC} at pin 4. At lower full scale voltages, buffer and comparator offset voltage may add significant error. See table for threshold voltages.

Note 4: Pin 5 input current must be limited to ± 3 mA. The addition of a 39k resistor in series with pin 5 allows $\pm 100V$ signals without damage.

Note 5: Bar mode results when pin 9 is within 20 mV of V^+ . Dot mode results when pin 9 is pulled at least 200 mV below V^+ . LED #10 (pin 10 output current) is disabled if pin 9 is pulled 0.9V or more below V_{LED} .

Note 6: The maximum junction temperature of the LM3915 is 100°C. Devices must be derated for operation at elevated temperatures. Junction to ambient thermal resistance is 55°C/W for the molded DIP (N package).

Threshold Voltage (Note 3)

Output	dB	Min	Typ	Max	Output	dB	Min	Typ	Max
1	-27	0.422	0.447	0.531	6	-12	2.372	2.512	2.819
2	-24	0.596	0.631	0.750	7	-9	3.350	3.548	3.825
3	-21	0.841	0.891	1.059	8	-6	4.732	5.012	5.309
4	-18	1.189	1.259	1.413	9	-3	6.683	7.079	7.498
5	-15	1.679	1.778	1.995	10	0	9.985	10	10.015

Typical Performance Characteristics

Supply Current vs Temperature

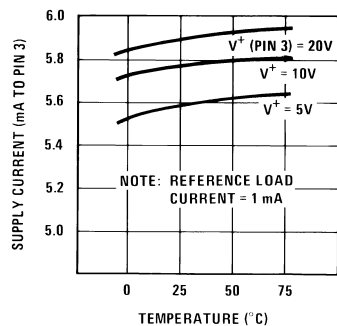

DS005104-34

Operating Input Bias Current vs Temperature

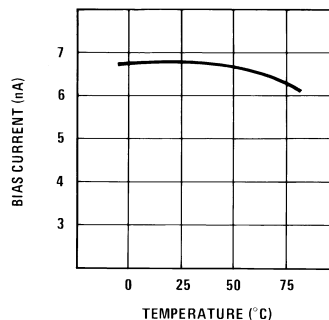

DS005104-35

Reference Voltage vs Temperature

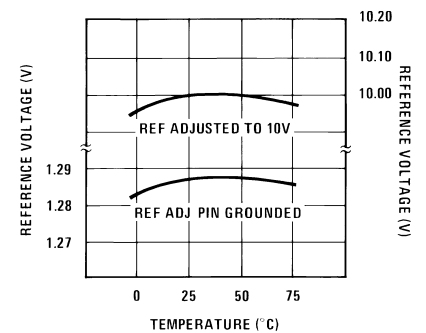

DS005104-36

Reference Adjust Pin Current vs Temperature

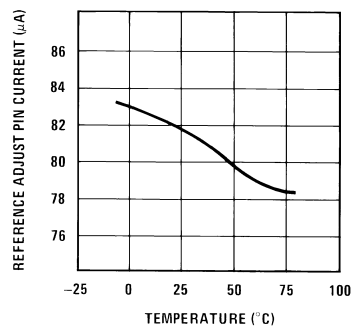

DS005104-37

LED Current-Regulation Dropout

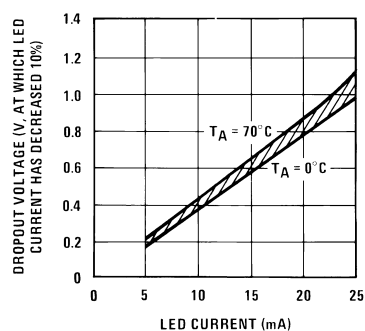

DS005104-38

LED Driver Saturation Voltage

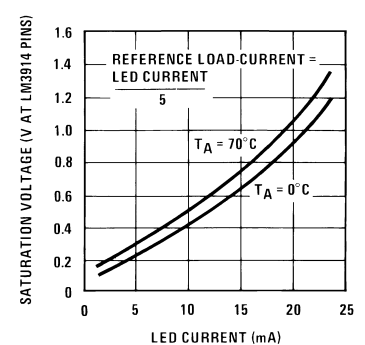

DS005104-39

Typical Performance Characteristics (Continued)

Input Current Beyond Signal Range (Pin 5)

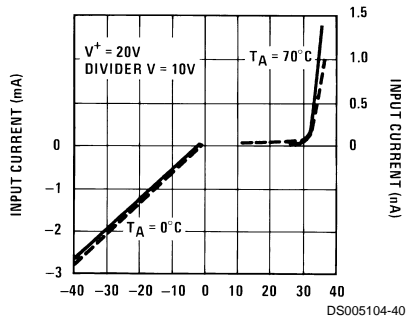

LED Current vs Reference Loading

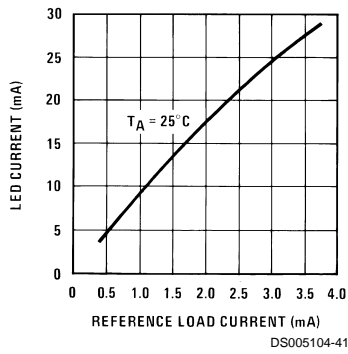

LED Driver Current Regulation

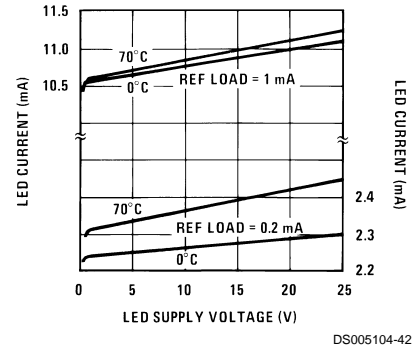

Total Divider Resistance vs Temperature

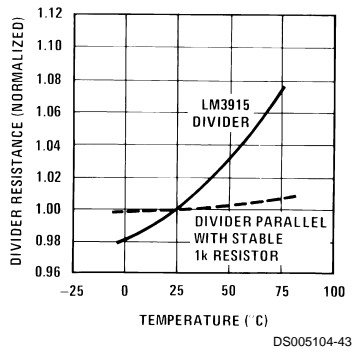

Common-Mode Limits

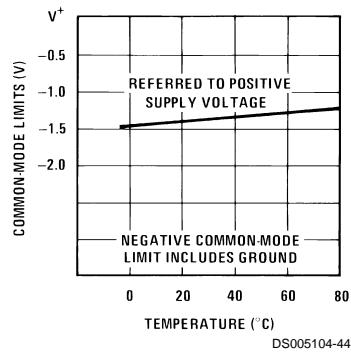

Output Characteristics

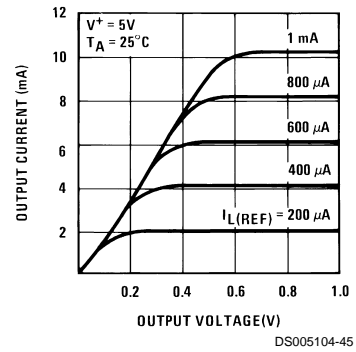

Block Diagram (Showing Simplest Application)

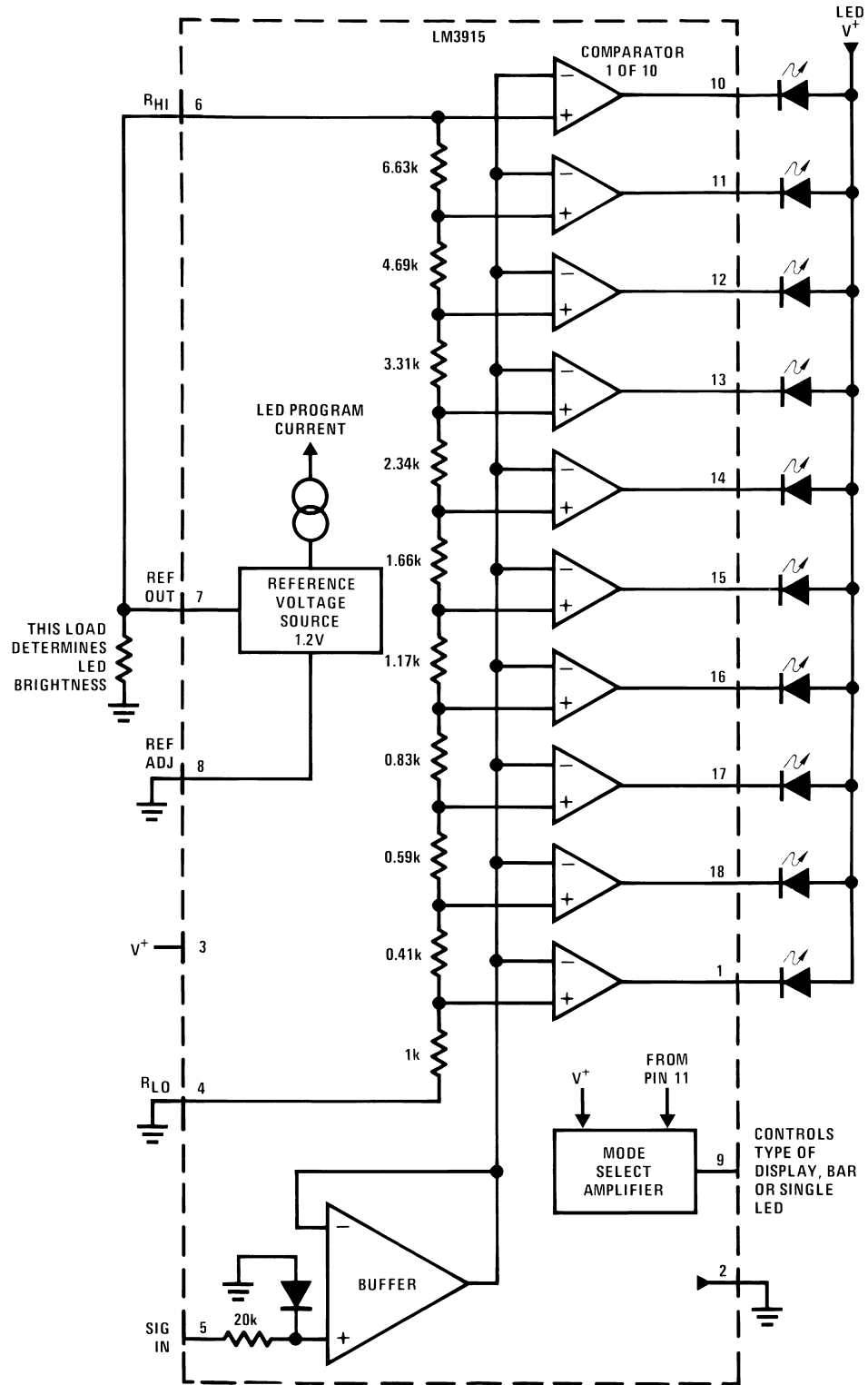

DS005104-4

Functional Description

The simplified LM3915 block diagram is included to give the general idea of the circuit's operation. A high input impedance buffer operates with signals from ground to 12V, and is protected against reverse and overvoltage signals. The signal is then applied to a series of 10 comparators; each of which is biased to a different comparison level by the resistor string.

In the example illustrated, the resistor string is connected to the internal 1.25V reference voltage. In this case, for each 3 dB that the input signal increases, a comparator will switch on another indicating LED. This resistor divider can be connected between any 2 voltages, providing that they are at least 1.5V below V^+ and no lower than V^- .

INTERNAL VOLTAGE REFERENCE

The reference is designed to be adjustable and develops a nominal 1.25V between the REF OUT (pin 7) and REF ADJ (pin 8) terminals. The reference voltage is impressed across program resistor R1 and, since the voltage is constant, a constant current I_1 then flows through the output set resistor R2 giving an output voltage of:

$$V_{OUT} = V_{REF} \left(1 + \frac{R_2}{R_1} \right) + I_{ADJ} R_2$$

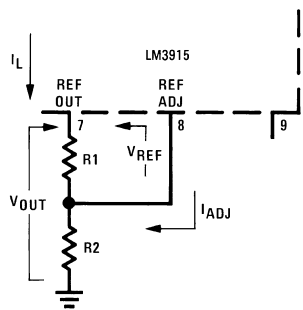

DS005104-5

Since the 120 μ A current (max) from the adjust terminal represents an error term, the reference was designed to minimize changes of this current with V^+ and load changes. For correct operation, reference load current should be between 80 μ A and 5 mA. Load capacitance should be less than 0.05 μ F.

CURRENT PROGRAMMING

A feature not completely illustrated by the block diagram is the LED brightness control. The current drawn out of the reference voltage pin (pin 7) determines LED current. Approximately 10 times this current will be drawn through each lighted LED, and this current will be relatively constant despite supply voltage and temperature changes. Current drawn by the internal 10-resistor divider, as well as by the external current and voltage-setting divider should be included in calculating LED drive current. The ability to modulate LED brightness with time, or in proportion to input voltage and other signals can lead to a number of novel displays or ways of indicating input overvoltages, alarms, etc.

The LM3915 outputs are current-limited NPN transistors as shown below. An internal feedback loop regulates the transistor drive. Output current is held at about 10 times the reference load current, independent of output voltage and processing variables, as long as the transistor is not saturated.

LM3915 Output Circuit

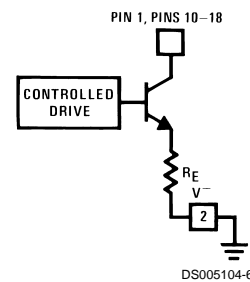

DS005104-6

Outputs may be run in saturation with no adverse effects, making it possible to directly drive logic. The effective saturation resistance of the output transistors, equal to R_E plus the transistors' collector resistance, is about 50 Ω . It's also possible to drive LEDs from rectified AC with no filtering. To avoid oscillations, the LED supply should be bypassed with a 2.2 μ F tantalum or 10 μ F aluminum electrolytic capacitor.

MODE PIN USE

Pin 9, the Mode Select input, permits chaining of multiple LM3915s, and controls bar or dot mode operation. The following tabulation shows the basic ways of using this input. Other more complex uses will be illustrated in the applications.

Bar Graph Display: Wire Mode Select (pin 9) *directly* to pin 3 (V^+ pin).

Dot Display, Single LM3915 Driver: Leave the Mode Select pin open circuit.

Dot Display, 20 or More LEDs: Connect pin 9 of the *first* driver in the series (i.e., the one with the lowest input voltage comparison points) to pin 1 of the next higher LM3915 driver. Continue connecting pin 9 of lower input drivers to pin 1 of higher input drivers for 30 or more LED displays. The last LM3915 driver in the chain will have pin 9 left open. All previous drivers should have a 20k resistor in parallel with LED #9 (pin 11 to V_{LED}).

Mode Pin Functional Description

This pin actually performs two functions. Refer to the simplified block diagram below.

Block Diagram of Mode Pin Function

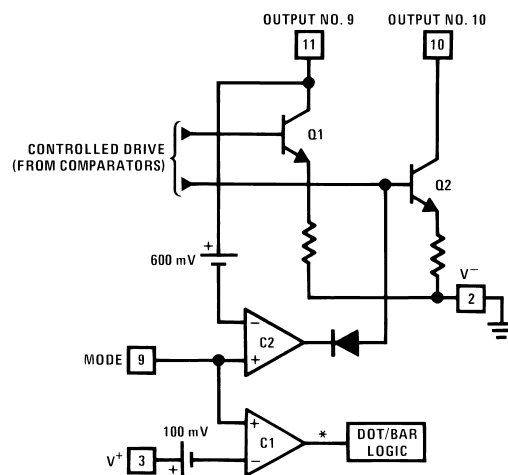

DS005104-7

*High for bar

Application Hints (Continued)

Power dissipation, especially in bar mode should be given consideration. For example, with a 5V supply and all LEDs programmed to 20 mA the driver will dissipate over 600 mW. In this case a 7.5 Ω resistor in series with the LED supply will cut device heating in half. The negative end of the resistor should be bypassed with a 2.2 μ F solid tantalum capacitor to pin 2.

TIPS ON RECTIFIER CIRCUITS

The simplest way to display an AC signal using the LM3915 is to apply it right to pin 5 unrectified. Since the LED illuminated represents the instantaneous value of the AC waveform, one can readily discern both peak and average values of audio signals in this manner. The LM3915 will respond to positive half-cycles only but will not be damaged by signals up to ± 35 V (or up to ± 100 V if a 39k resistor is in series with the input). It's recommended to use dot mode and to run the LEDs at 30 mA for high enough average intensity.

True average or peak detection requires rectification. If an LM3915 is set up with 10V full scale across its voltage divider, the turn-on point for the first LED is only 450 mV. A simple silicon diode rectifier won't work well at the low end due to the 600 mV diode threshold. The half-wave peak detector in *Figure 1* uses a PNP emitter-follower in front of the diode. Now, the transistor's base-emitter voltage cancels out the diode offset, within about 100 mV. This approach is usually satisfactory when a single LM3915 is used for a 30 dB display.

Display circuits using two or more LM3915s for a dynamic range of 60 dB or greater require more accurate detection. In the precision half-wave rectifier of *Figure 2* the effective diode offset is reduced by a factor equal to the open-loop gain of the op amp. Filter capacitor C2 charges through R3 and discharges through R2 and R3, so that appropriate selection of these values results in either a peak or an average detector. The circuit has a gain equal to $R2/R1$.

It's best to capacitively couple the input. Audio sources frequently have a small DC offset that can cause significant error at the low end of the log display. Op amps that slew quickly, such as the LF351, LF353, or LF356, are needed to faithfully respond to sudden transients. It may be necessary to trim out the op amp DC offset voltage to accurately cover a 60 dB range. Best results are obtained if the circuit is adjusted for the correct output when a low-level AC signal (10 mV to 20 mV) is applied, rather than adjusting for zero output with zero input.

For precision full-wave averaging use the circuit in *Figure 3*. Using 1% resistors for R1 through R4, gain for positive and

negative signal differs by only 0.5 dB worst case. Substituting 5% resistors increases this to 2 dB worst case. (A 2 dB gain difference means that the display may have a ± 1 dB error when the input is a nonsymmetrical transient). The averaging time constant is $R5-C2$. A simple modification results in the precision full-wave detector of *Figure 4*. Since the filter capacitor is not buffered, this circuit can drive only high impedance loads such as the input of an LM3915.

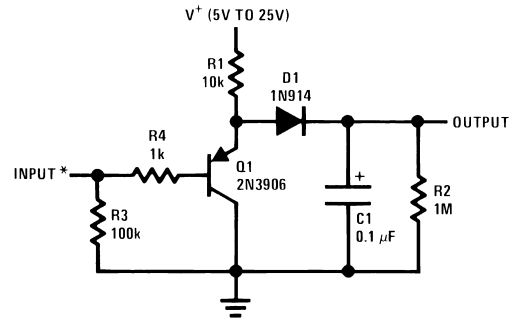

DS005104-9

*DC Couple

FIGURE 1. Half-Wave Peak Detector

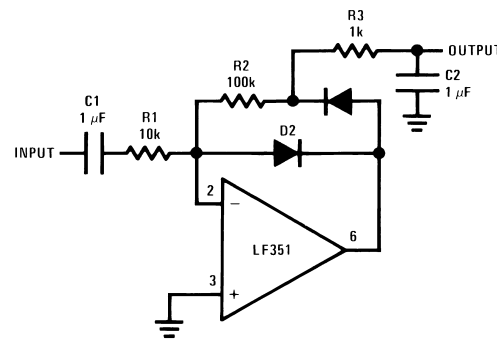

DS005104-10

D1, D2: 1N914 or 1N4148

	Average	Peak
R2	1k	100k
R3	100k	1k

R1 = R2 for $A_V = 1$ R1 = $R2/R10$ for $A_V = 10$ C1 = $10/R1$

FIGURE 2. Precision Half-Wave Rectifier

Application Hints (Continued)

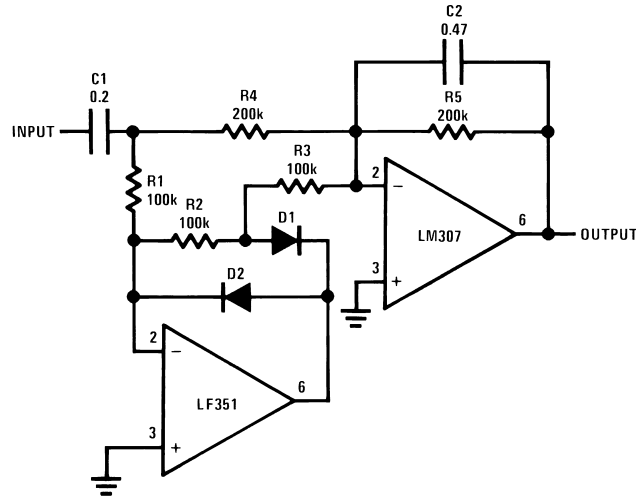

DS005104-11

D1, D2: 1N914 or 1N4148

FIGURE 3. Precision Full-Wave Average Detector

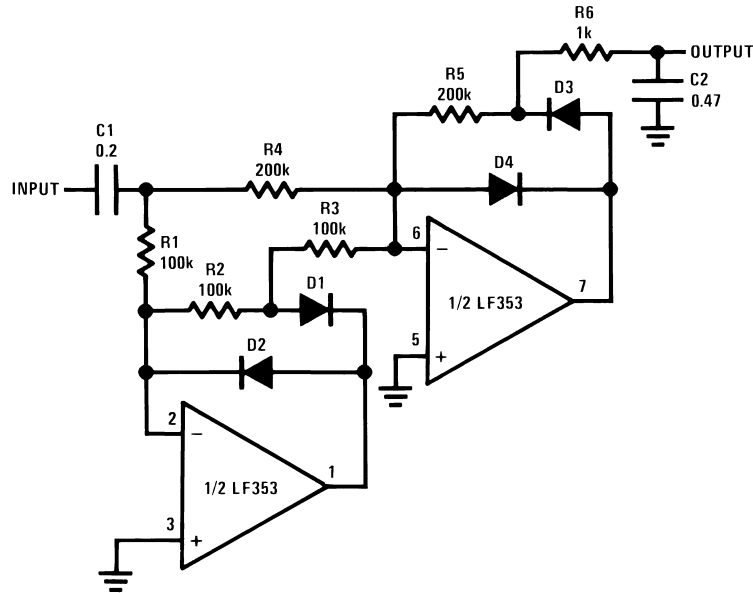

DS005104-12

D1, D2, D3, D4: 1N914 or 1N4148

FIGURE 4. Precision Full-Wave Peak Detector

CASCADING THE LM3915

To display signals of 60 dB or 90 dB dynamic range, multiple LM3915s can be easily cascaded. Alternatively, it is possible to cascade an LM3915 with LM3914s for a log/linear display or with an LM3916 to get an extended range VU meter.

A simple, low cost approach to cascading two LM3915s is to set the reference voltages of the two chips 30 dB apart as in *Figure 5*. Potentiometer R1 is used to adjust the full scale voltage of LM3915 #1 to 316 mV nominally while the second IC's reference is set at 10V by R4. The drawback of this method is that the threshold of LED #1 is only 14 mV and, since the LM3915 can have an offset voltage as high as 10 mV, large errors can occur. This technique is not recommended for 60 dB displays requiring good accuracy at the first few display thresholds.

A better approach shown in *Figure 6* is to keep the reference at 10V for both LM3915s and amplify the input signal to the lower LM3915 by 30 dB. Since two 1% resistors can set the amplifier gain within ± 0.2 dB, a gain trim is unnecessary. However, an op amp offset voltage of 5 mV will shift the first LED threshold as much as 4 dB, so that an offset trim may be required. Note that a single adjustment can null out offset in both the precision rectifier and the 30 dB gain stage. Alternatively, instead of amplifying, input signals of sufficient amplitude can be fed directly to the lower LM3915 and *attenuated* by 30 dB to drive the second LM3915.

Application Hints (Continued)

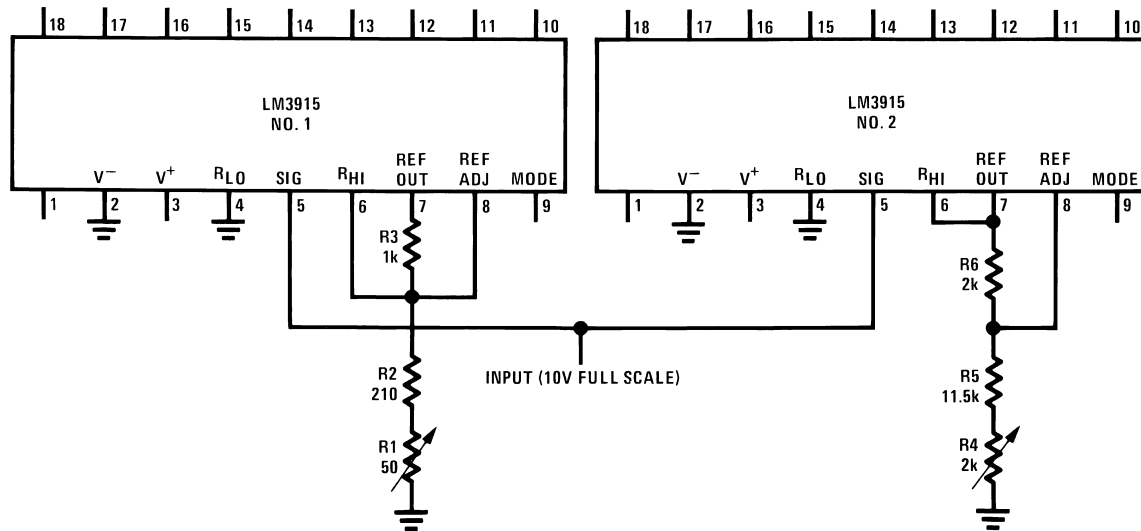

DS005104-13

FIGURE 5. Low Cost Circuit for 60 dB Display

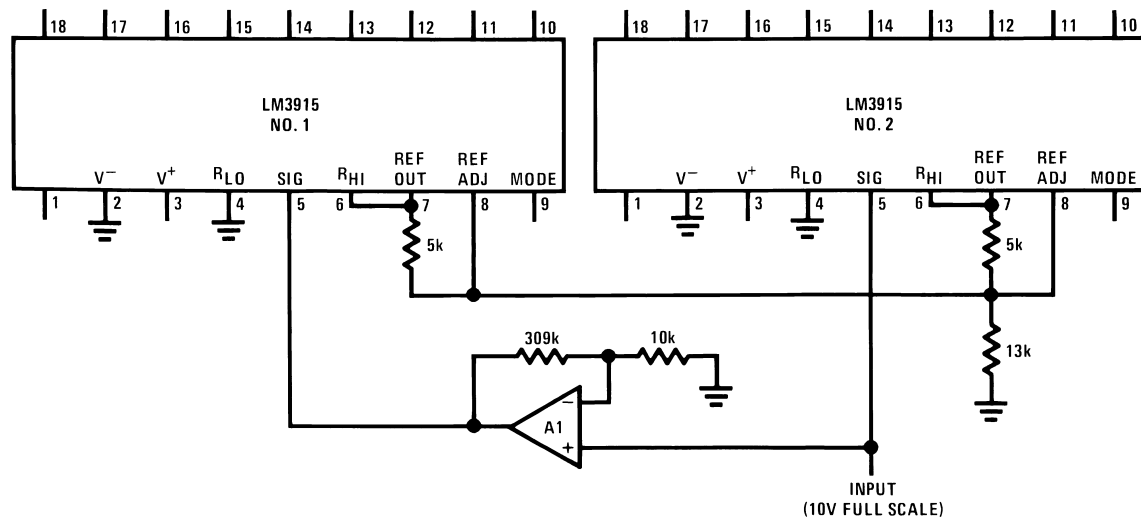

DS005104-14

FIGURE 6. Improved Circuit for 60 dB Display

To extend this approach to get a 90 dB display, another 30 dB of amplification must be placed in the signal path ahead of the lowest LM3915. Extreme care is required as the lowest LM3915 displays input signals down to 0.5 mV! Several offset nulls may be required. High currents should not share the same path as the low level signal. Also power line wiring should be kept away from signal lines.

TIPS ON REFERENCE VOLTAGE AND LED CURRENT PROGRAMMING

SINGLE LM3915

The equations in *Figure 7* illustrate how to choose resistor values to set reference voltage for the simple case where no LED intensity adjustment is required. A LED current of 10 mA to 20 mA generally produces adequate illumination. Having 10V full-scale across the internal voltage divider gives best accuracy by keeping signal level high relative to the offset voltage of the internal comparators. However, this causes

450 μ A to flow from pin 7 into the divider which means that the LED current will be at least 5 mA. R1 will typically be between 1 k Ω and 2 k Ω . To trim the reference voltage, vary R2.

The circuit in *Figure 8* shows how to add a LED intensity control which can vary LED current from 9 mA to 28 mA. The reference adjustment has some effect on LED intensity but the reverse is not true.

MULTIPLE LM3915s

Figure 9 shows how to obtain a common reference trim and intensity control for two LM3915s. The two ICs may be connected in cascade for a 60 dB display or may be handling separate channels for stereo. This technique can be extended for larger numbers of LM3915s by varying the values of R1, R2 and R3 in inverse proportion to the number of devices tied in. The ICs' internal references track within 100 mV so that worst case error from chip to chip is only 0.1 dB for $V_{REF} = 10V$.

Application Hints (Continued)

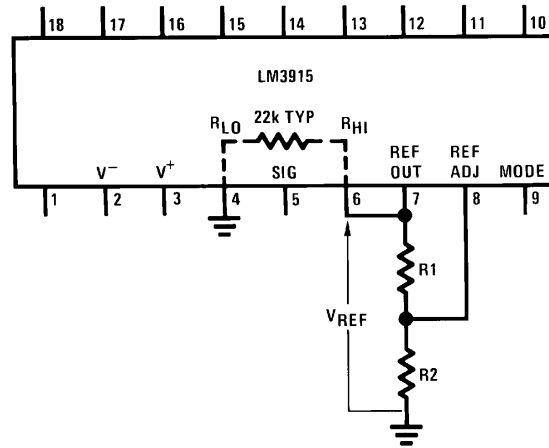

DS005104-15

Adjust R2 to vary V_{REF}

$$\text{Pick } R1 = \frac{12.5V}{I_{LED} - V_{REF}/2.2 \text{ k}\Omega}$$

$$\text{Pick } R2 = \frac{(V_{REF} - 1.25V)}{(1.25V/R1) + 0.08 \text{ mA}}$$

FIGURE 7. Design Equations for Fixed LED Intensity

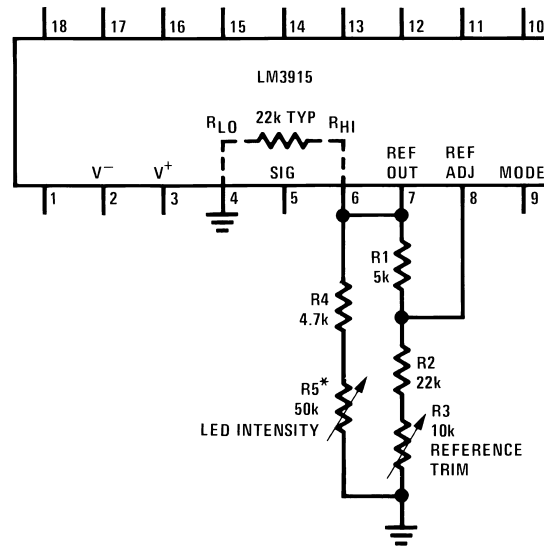

DS005104-16

*9 mA < I_{LED} < 28 mA @ $V_{REF} = 10V$

FIGURE 8. Varying LED Intensity

Application Hints (Continued)

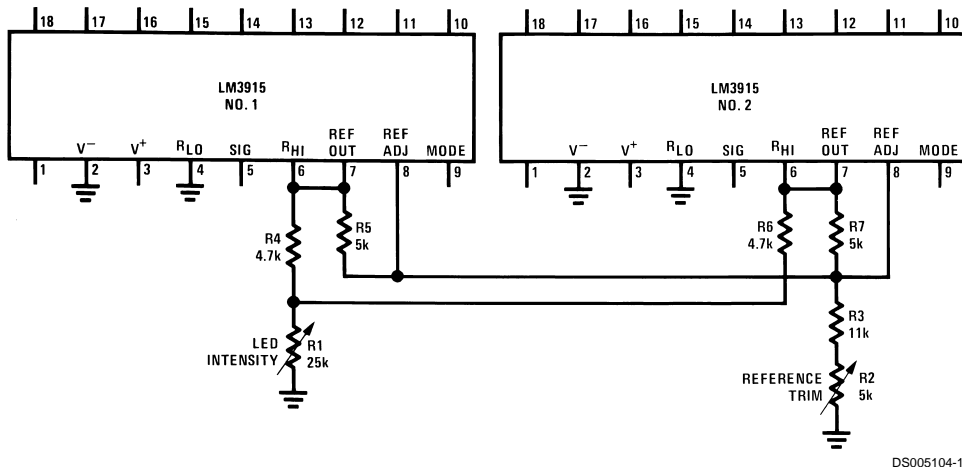

DS005104-17

FIGURE 9. Independent Adjustment of Reference Voltage and LED Intensity for Multiple LM3915s

The scheme in *Figure 10* is useful when the reference and LED intensity must be adjusted independently over a wide range. The R_{HI} voltage can be adjusted from 1.2V to 10V with no effect on LED current. Since the internal divider here does not load down the reference, minimum LED current is much lower. At the minimum recommended reference load of $80\ \mu\text{A}$, LED current is about 0.8 mA. The resistor values shown give a LED current range from 1.5 mA to 20 mA.

At the low end of the intensity adjustment, the voltage drop across the $510\ \Omega$ current-sharing resistors is so small that chip to chip variation in reference voltage may yield a visible variation in LED intensity. The optional approach shown of connecting the bottom end of the intensity control pot to a negative supply overcomes this problem by allowing a larger voltage drop across the (larger) current-sharing resistors.

Other Applications

For increased resolution, it's possible to obtain a display with a smooth transition between LEDs. This is accomplished by varying the reference level at pin 6 by 3 dBp-p as shown in *Figure 11*. The signal can be a triangle, sawtooth or sine wave from 60 Hz to 1 kHz. The display can be run in either dot or bar mode.

When an exponentially decaying RC discharge waveform is applied to pin 5, the LM3915's outputs will switch at equal intervals. This makes a simple timer or sequencer. Each time interval is equal to $RC/3$. The output may be used to drive logic, opto-couplers, relays or PNP transistors, for example.

Typical Applications

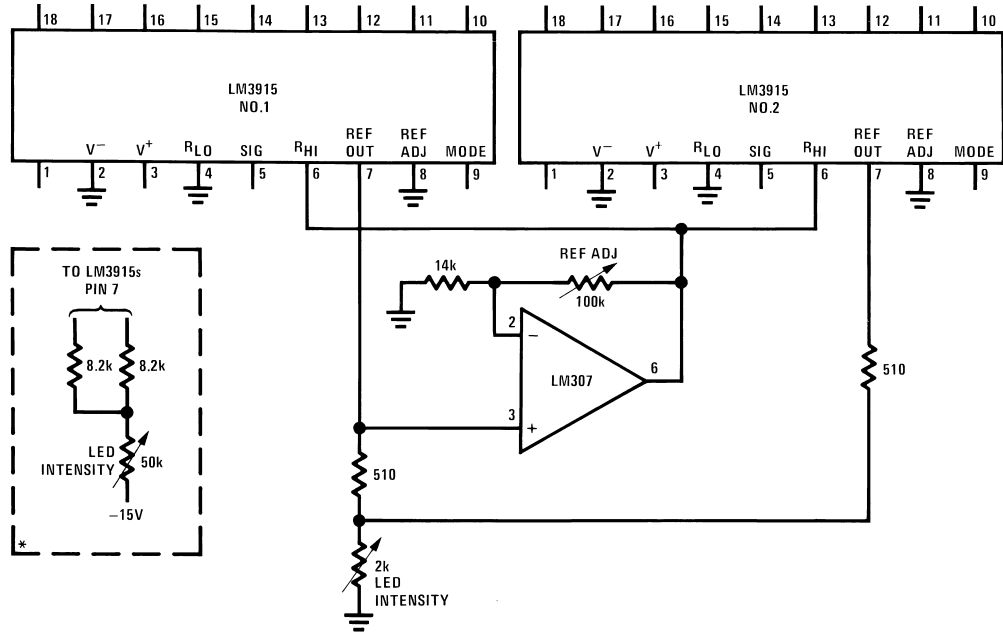

DS005104-18

*Optional circuit for improved intensity matching at low currents.
See text.

FIGURE 10. Wide-Range Adjustment of Reference Voltage and LED Intensity for Multiple LM3915s

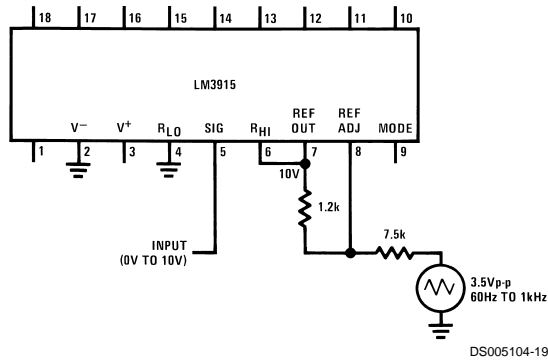

DS005104-19

FIGURE 11. 0V to 10V Log Display with Smooth Transitions

Typical Applications (Continued)

Extended Range VU Meter

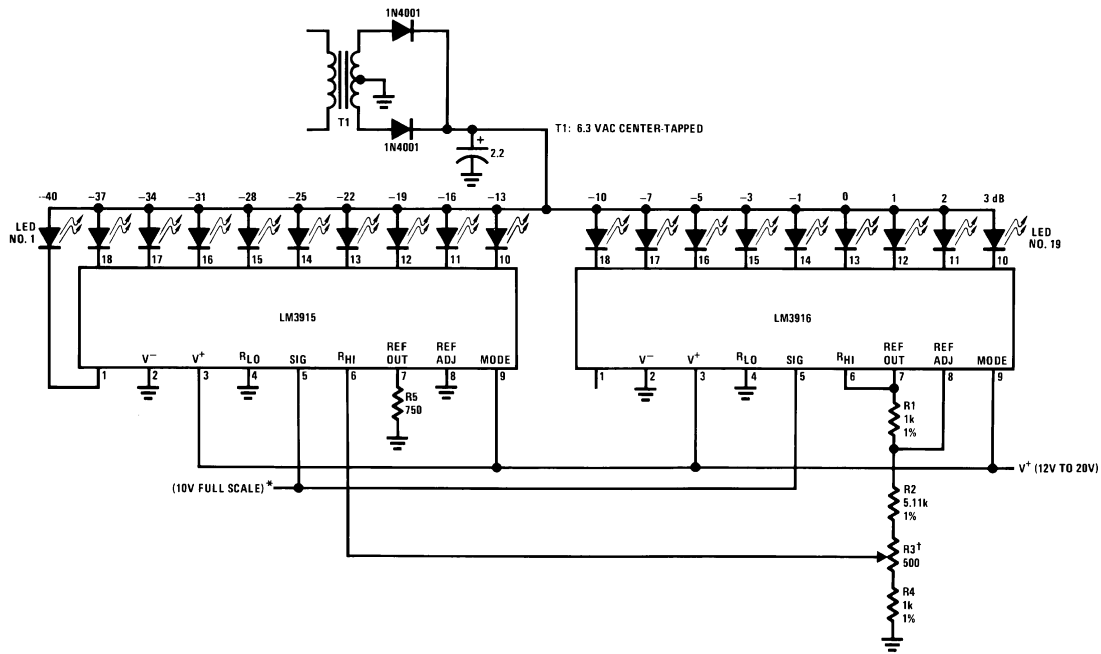

DS005104-20

This application shows that the LED supply requires minimal filtering.
 *See Application Hints for optional Peak or Average Detector.
 †Adjust R3 for 3 dB difference between LED #11 and LED #12.

Vibration Meter

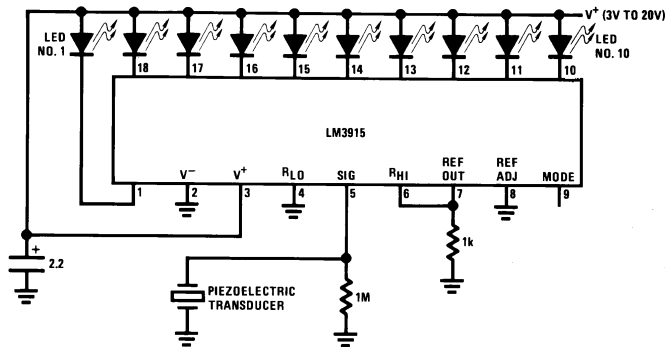

DS005104-21

LED	Threshold
1	60 mV
2	80 mV
3	110 mV
4	160 mV
5	220 mV
6	320 mV
7	440 mV
8	630 mV
9	890 mV
10	1.25V

Typical Applications (Continued)

Indicator and Alarm, Full-Scale Changes Display from Dot to Bar

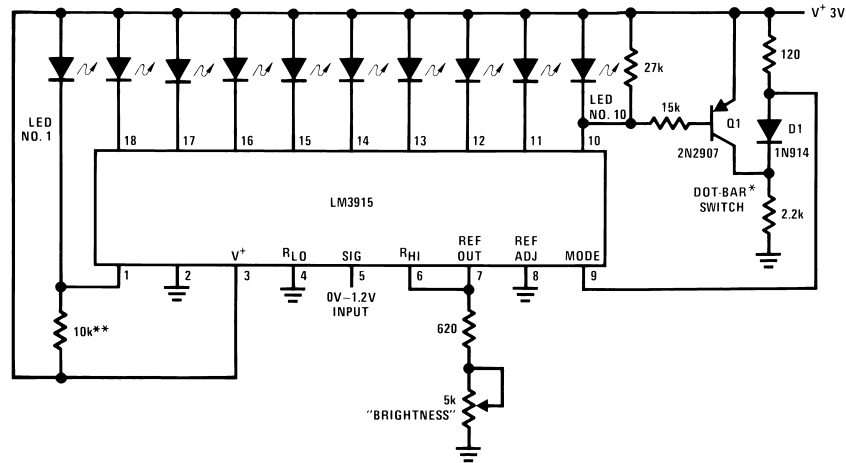

DS005104-22

*The input to the dot bar switch may be taken from cathodes of other LEDs.
 Display will change to bar as soon as the LED so selected begins to light.
 **Optional. Shunts 100 μ A auxiliary sink current away from LED #1.

60 dB Dot Mode Display

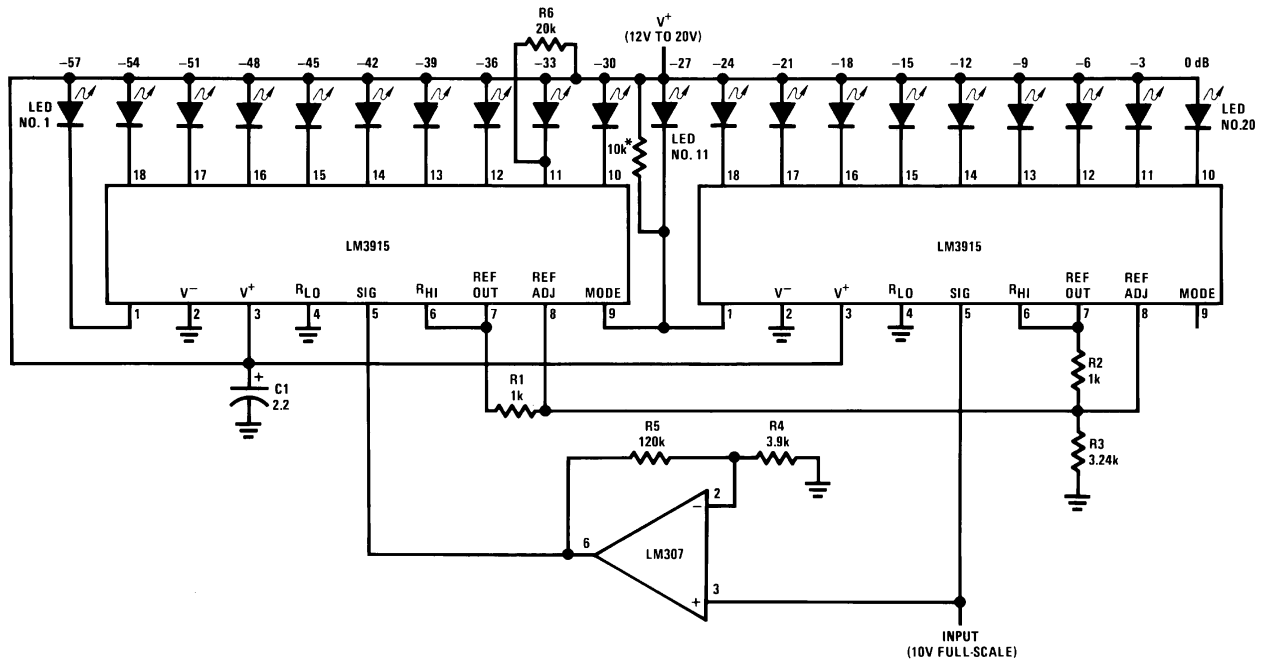

DS005104-23

**Optional. Shunts 100 μ A auxiliary sink current away from LED #11.

Typical Applications (Continued)

Driving Vacuum Fluorescent Display

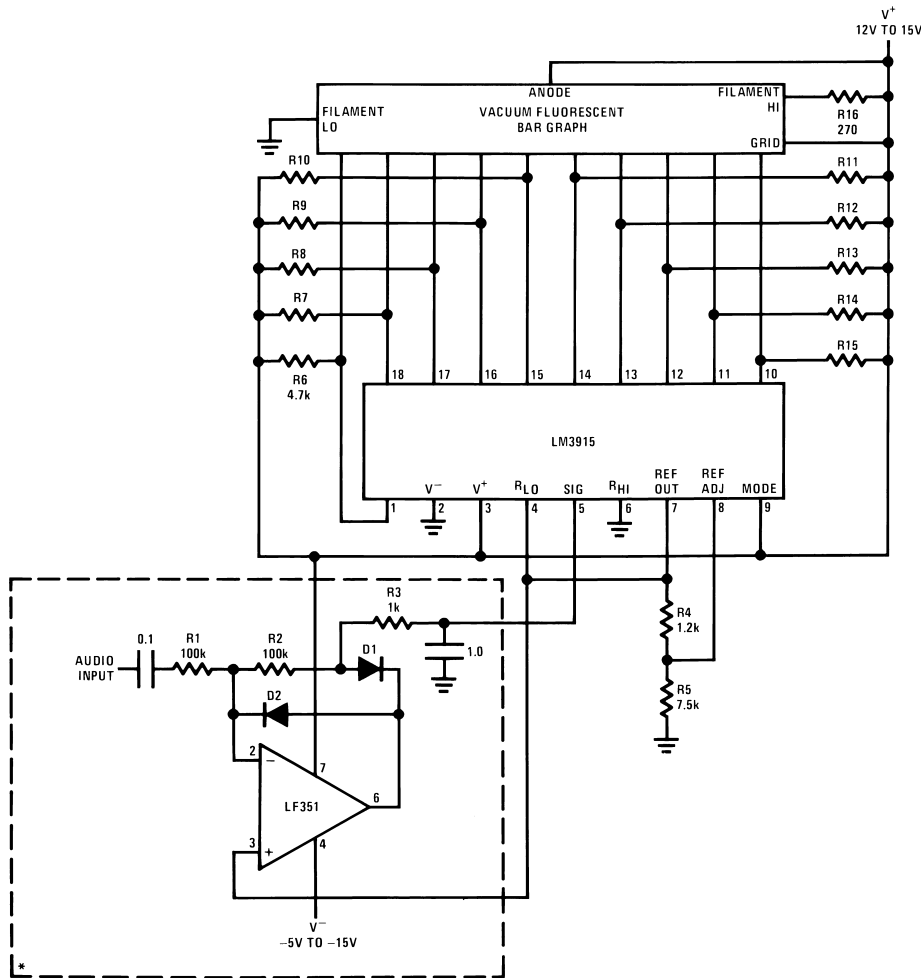

DS005104-24

R7 thru R15: 10k ±10%
 D1, D2: 1N914 or 1N4148
 *Half-wave peak detector.
 See Application Hints.

Low Current Bar Mode Display

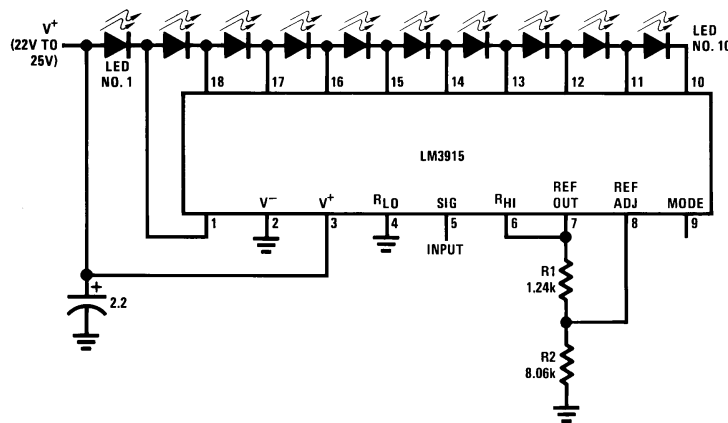

DS005104-25

Supply current drain is only 15 mA with ten LEDs illuminated.

Typical Applications (Continued)

Driving Liquid Crystal Display

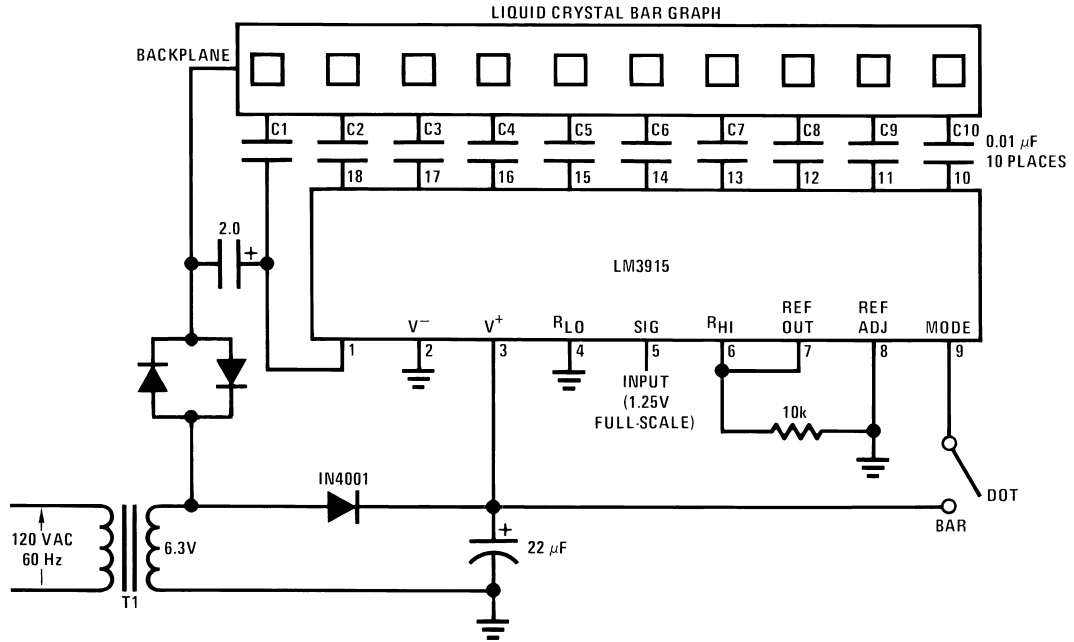

DS005104-26

Bar Display with Alarm Flasher

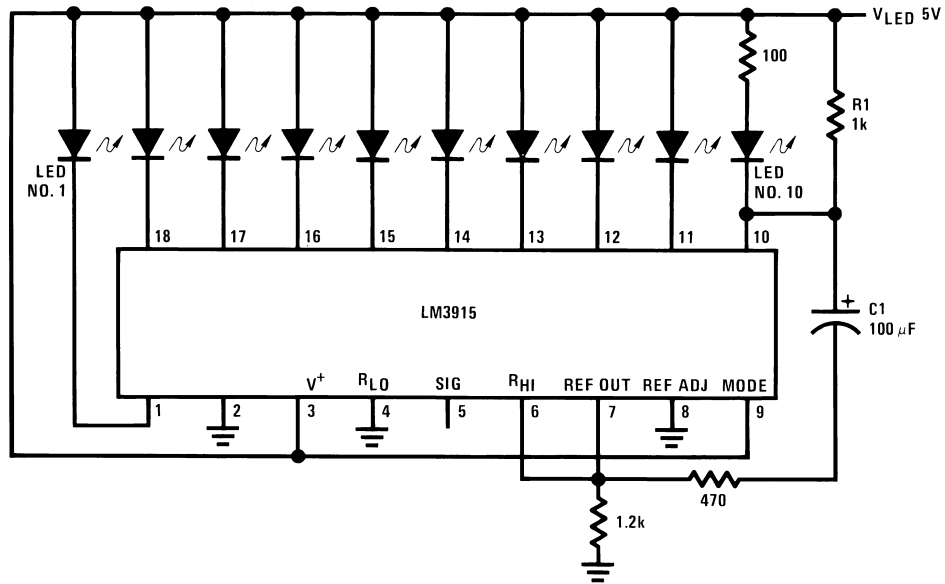

DS005104-27

Full-scale causes the full bar display to flash. If the junction of R1 and C1 is connected to a different LED cathode, the display will flash when that LED lights, and at any higher input signal.

Typical Applications (Continued)

Audio Power Meter

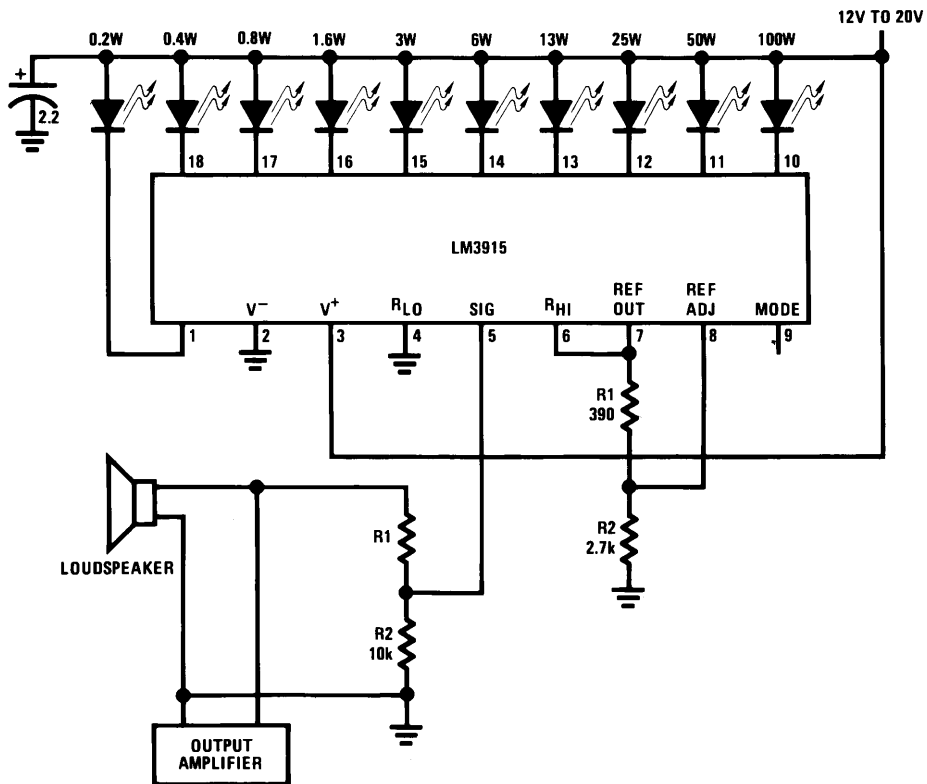

DS005104-31

Load Impedance	R1
4Ω	10k
8Ω	18k
16Ω	30k

See Application Hints for optional Peak or Average Detector

Connection Diagram

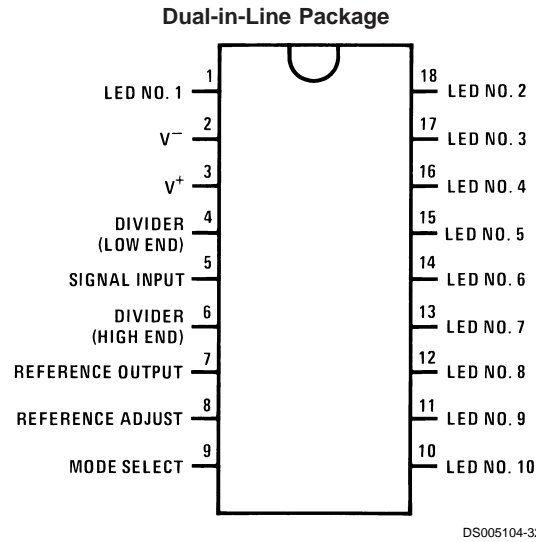

Top View

Order Number LM3915N-1
See NS Package Number NA18A
Order Number LM3915N *

See NS Package Number N18A

*Discontinued, Life Time Buy date 12/20/99

Definition of Terms

Absolute Accuracy: The difference between the observed threshold voltage and the ideal threshold voltage for each comparator. Specified and tested with 10V across the internal voltage divider so that resistor ratio matching error predominates over comparator offset voltage.

Adjust Pin Current: Current flowing out of the reference adjust pin when the reference amplifier is in the linear region.

Comparator Gain: The ratio of the change in output current (I_{LED}) to the change in input voltage (V_{IN}) required to produce it for a comparator in the linear region.

Dropout Voltage: The voltage measured at the current source outputs required to make the output current fall by 10%.

Input Bias Current: Current flowing out of the signal input when the input buffer is in the linear region.

LED Current Regulation: The change in output current over the specified range of LED supply voltage (V_{LED}) as mea-

sured at the current source outputs. As the forward voltage of an LED does not change significantly with a small change in forward current, this is equivalent to changing the voltage at the LED anodes by the same amount.

Line Regulation: The average change in reference output voltage (V_{REF}) over the specified range of supply voltage (V^+).

Load Regulation: The change in reference output voltage over the specified range of load current ($I_{L(REF)}$).

Offset Voltage: The differential input voltage which must be applied to each comparator to bias the output in the linear region. Most significant error when the voltage across the internal voltage divider is small. Specified and tested with pin 6 voltage (V_{RHI}) equal to pin 4 voltage (V_{RLO}).

Relative Accuracy: The difference between any two adjacent threshold points. Specified and tested with 10V across the internal voltage divider so that resistor ratio matching error predominates over comparator offset voltage.

Physical Dimensions inches (millimeters) unless otherwise noted

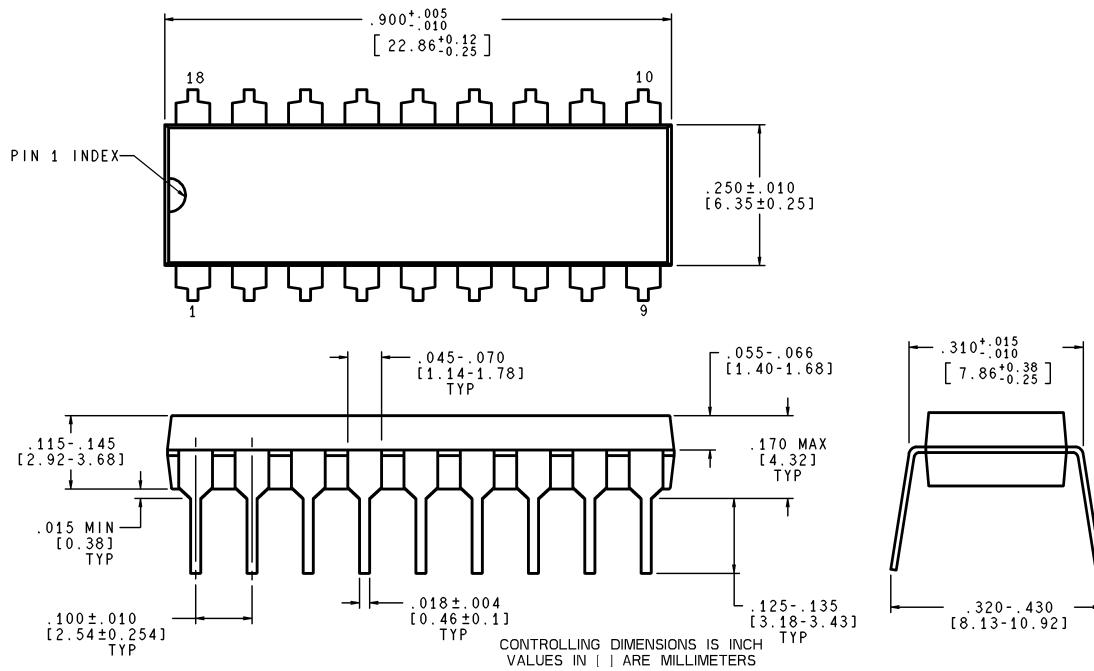

NA18A (Rev A)

Note: Unless otherwise specified.

- Standard Lead Finish:
 - 200 microinches /5.08 micrometer minimum
 - lead/tin 37/63 or 15/85 on alloy 42 or equivalent or copper
- Reference JEDEC registration MS-001, Variation AC, dated May 1993.

Molded Dual-In-Line Package (N)
Order Number LM3915N-1
NS Package Number NA18A

Physical Dimensions inches (millimeters) unless otherwise noted (Continued)

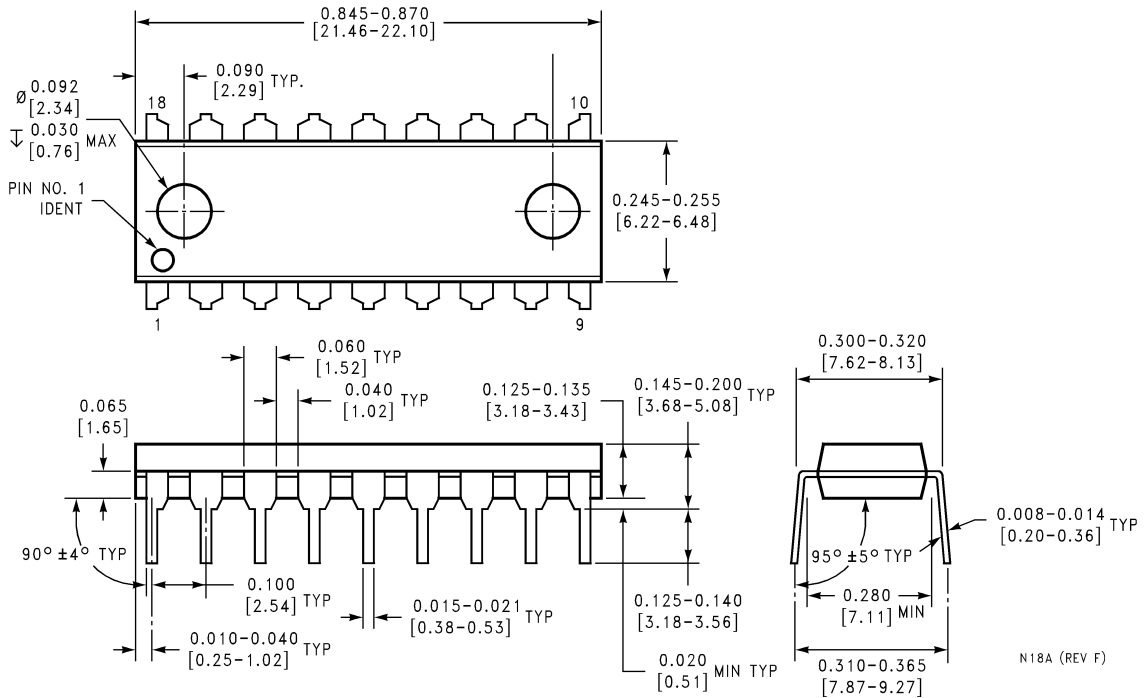

Molded Dual-In-Line Package (N)

Order Number LM3915N *

NS Package Number N18A

***Discontinued, Life Time Buy date 12/20/99**

LIFE SUPPORT POLICY

NATIONAL'S PRODUCTS ARE NOT AUTHORIZED FOR USE AS CRITICAL COMPONENTS IN LIFE SUPPORT DEVICES OR SYSTEMS WITHOUT THE EXPRESS WRITTEN APPROVAL OF THE PRESIDENT AND GENERAL COUNSEL OF NATIONAL SEMICONDUCTOR CORPORATION. As used herein:

1. Life support devices or systems are devices or systems which, (a) are intended for surgical implant into the body, or (b) support or sustain life, and whose failure to perform when properly used in accordance with instructions for use provided in the labeling, can be reasonably expected to result in a significant injury to the user.
2. A critical component is any component of a life support device or system whose failure to perform can be reasonably expected to cause the failure of the life support device or system, or to affect its safety or effectiveness.



National Semiconductor Corporation
Americas
Tel: 1-800-272-9959
Fax: 1-800-737-7018
Email: support@nsc.com
www.national.com

National Semiconductor Europe
Fax: +49 (0) 180-530 85 86
Email: europe.support@nsc.com
Deutsch Tel: +49 (0) 69 9508 6208
English Tel: +44 (0) 870 24 0 2171
Français Tel: +33 (0) 1 41 91 8790

National Semiconductor Asia Pacific Customer Response Group
Tel: 65-2544466
Fax: 65-2504466
Email: ap.support@nsc.com

National Semiconductor Japan Ltd.
Tel: 81-3-5639-7560
Fax: 81-3-5639-7507