



The HS20 is a compact, rugged encoder designed with the needs of the small motor market in mind. It can be used where lighter duty encoders are not suitable or cost effective. The compact design makes it easy to incorporate into tight installations and the IP64 rating means it will stand up to dust, dirt, and splashing liquids.

Other features include dual preloaded bearings for longevity and stability, differential line driver outputs for noise immunity and a standard, Euro-style 8-pin sealed connector for easy connectivity. A specially designed, non-marring shaft clamp allows for easy installation and eliminates shaft damage should you need to reinstall or reposition the encoder on the shaft.

Mechanical Specifications

- Shaft Bore:** 5/8", 1/2", 1/4", metric available
- Allowable Misalignment:** 0.005 TIR, 0.010 Axial using R2 Tether
- Bore Runout:** 0.001 TIR
- Starting Torque at 25°C:** 3.5 in-oz (max)
- Bearings:** 52100 dual preloaded bearings
- Shaft Material:** Aluminum
- Bearing Housing:** Aluminum with protective finish
- Cover:** Aluminum with protective finish
- Bearing Life:** 7.5 X 10⁹ revs
- Maximum RPM:** 6000 (see frequency response)
- Moment of Inertia:** 3.4 X 10⁻⁴ oz-in-sec²
- Weight:** 8 ounces, maximum

Electrical Specifications

- Code:** Incremental output format; 2 channels in quadrature, with complements; 1/2 cycle index gated with negative B channel
- Cycles Per Shaft Turn:** 2 through 1024
- Supply Voltage:** 5–28 VDC ± 5%
- Current Requirements:** 100mA typical + output load, 250mA (max)
- Voltage/Output:** (see note 5)
 28V/V: Line Driver, 5–28 VDC in, V_{out} = Vin
 28V/5: Line Driver, 5–28 VDC in, V_{out} = 5 VDC
 28V/OC: Open Collector, 5–28 VDC in, OC_{out}
 (Higher frequency response may be available. Please consult with the factory.)
- Protection Level:** Overvoltage, reverse voltage. Outputs short-circuit protected (1 minute max) (see note 5)
- Frequency Response:** 100kHz
- Output Termination Pinouts:** see Table 1, back page

Environmental Specifications

- Enclosure Rating:** IP64
- Temperature:** 0–70° Standard
- Shock:** 50 g's for 11 msec duration
- Vibration:** 5–2000 Hz @ 20 g's
- Humidity:** 98% RH non-condensing

NOTES AND TABLES: All notes and tables referred to in the text can be found on the back page.

HS20 Incremental Ordering Options

FOR ASSISTANCE CALL 800-350-2727

Use this diagram, working from left to right to construct your model number (example: HS20-50-R2-SS-1024-ABZC-28V/V-K8).

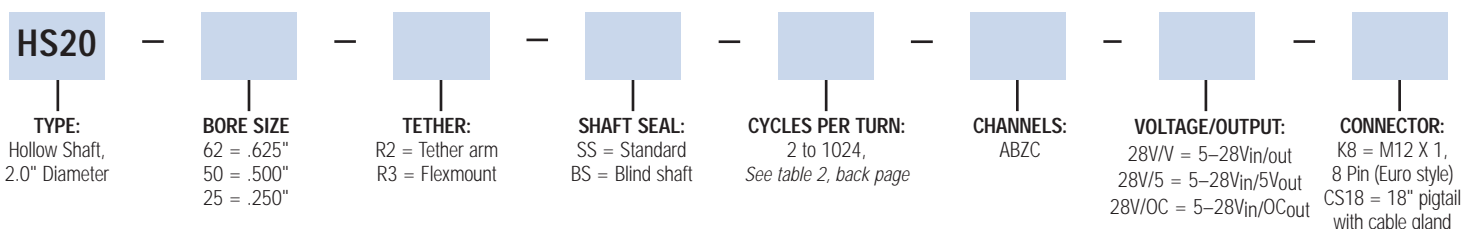

These commodities, technology or software if exported from the United States must be in accordance with the Bureau of Industry, and Security, Export Administration regulations. Diversion contrary to U.S. law is prohibited.

Tel: 805-968-0782 / 800-350-2727 | Fax: 805-968-3154 / 800-960-2726 | 7230 Hollister Ave., Goleta, CA 93117-2807 | www.beied.com

Specification No. 924-02082-001 Rev.06-08

Dimensions

R2 Tether Arm

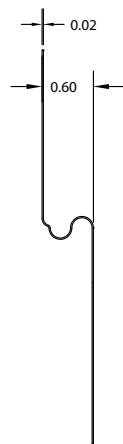
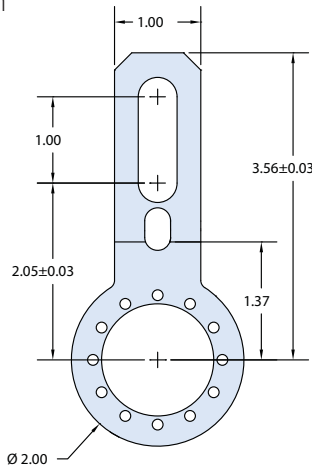

HS20 Diagram

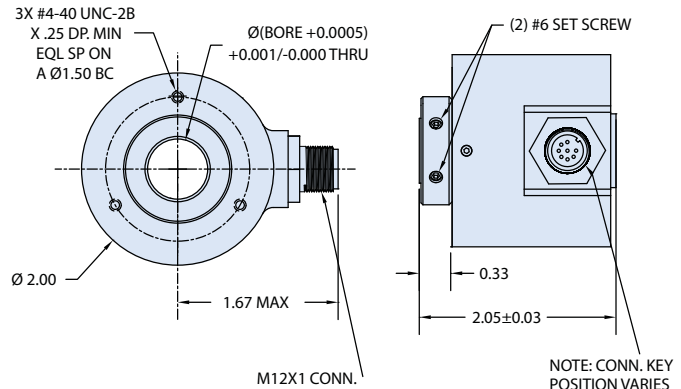

Tables and Figures

Table 1—Output Termination Pinouts

PIN (K8)	WIRE	FUNCTION
1	YEL	A
4	BLU	B
6	ORN	Z
2	RED	+V (SUPPLY)
7	BLK	OV (CIRCUIT COMMON)
N/C	GRN	CASE GROUND
3	W/YEL	\bar{A}
5	W/BLU	\bar{B}
8	W/ORN	\bar{Z}

Table 2—HS20 Disc Resolutions

2	3	5	6	8	10	11	12	24	25	30	32	40	50	60	64
70	75	80	100	105	115	120	125	150	192	200					
240	250	256	300	336	400	410	500	512	600						
720	785	1000	1024												

Figure 1 Output Waveform

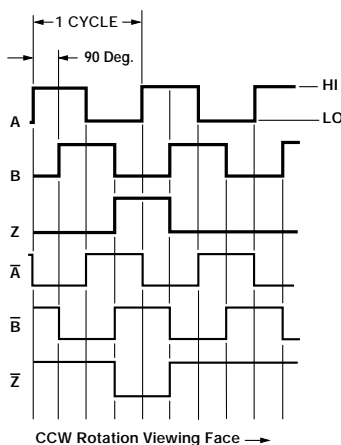

Notes

1. Mounting is usually done either using the D-style square flange mount, E- or G-style servo mounts, or one of the standard face mounts, F1 for example. Consult factory for additional face mount options.

2. The shaft seal is recommended in virtually all installations. The most common exceptions are applications requiring a very low starting torque or those requiring operation at both high temperature and high speed.

3. Non-standard index widths and multiple indices are available by special order. Consult factory.

4. Complementary outputs are recommended for use with line driver type (source/sink) outputs. When used with differential receivers, this combination provides a high degree of noise immunity.

5. **Output IC's:** Output IC's are available as either Line Driver (LD) or NPN Open Collector (OC) types. Open Collectors require pull-up resistors, resulting in higher output source impedance (sink impedance is similar to that of line drivers). In general, use of a Line Driver style output is recommended. Line Drivers source or sink current and their lower impedance mean better noise immunity and faster switching times. **Warning:** Do not connect any line driver outputs directly to circuit common/OV, which may damage the driver. Unused outputs should be isolated and left floating. Our applications specialists would be pleased to discuss your system requirements and the compatibility of your receiving electronics with Line Driver type outputs.

28V/V: Multi-voltage Line Driver (7272*): 100 mA source/sink. Input voltage 5 to 28 VDC +/- 5% standard (Note: $V_{out} = V_{in}$). This driver is TTL compatible when used with 5 volt supply. Supply lines are protected against overvoltage to 60 volts and reverse voltage. Outputs are short circuit protected for one minute. Supply current is 120 mA typical (plus load current). This is the recommended replacement for 3904R and 7406R open collector outputs with internal pullup resistors. It is also a direct replacement for any 4469, 88C30, 8830 or 26LS31 line driver.

28V/5: Multi-voltage Line Driver (7272*): 100 mA source/sink. Input voltage 5 to 28 VDC +/- 5% standard, internally regulated with 5V (TTL compatible) logic out. Supply lines are protected against overvoltage to 60 volts and reverse voltage. Outputs are short circuit protected for one minute. Supply current is 90 mA typical (plus load current).

15V/V: Multi-voltage Line Driver (4469*): 100 mA source/sink. Input voltage 5 to 15 VDC +/- 5% standard (Note: $V_{out} = V_{in}$). TTL compatible when used with 5 volt supply. Supply lines are protected against overvoltage to 60 volts and reverse voltage. Outputs are short circuit protected for one minute. Supply current is 90 mA typical (plus load current). This is a direct replacement for the 4469 Line Driver.

28V/OC: NPN Open Collector (3904*, 7273*): Current sink of 80 mA max. Current sourced by external pull-up resistor. Output can be pulled up to voltage other than supply voltage (30 V max). Input voltage 5 to 28 VDC +/- 5% standard. Supply current is 120 mA typical. This replaces prior IC's with designations of 3904, 7406, 3302, 681 and 689.

5V/OCR, 15V/OCR, 24V/OCR: Open Collector (3904R*, 7406R*, 7273R*): Current sink of 70 mA max. Includes internal pull-ups sized at approximately 100 ohms/volt. Max current source is 10 mA. Supply current is 100 mA typical, 120 mA with internal pull-ups. The 5V/OCR, 15V/OCR and 24V/OCR are often replaced by the 28V/V in system upgrades.

3904, 3904R, 4469, 5V/V, 5V/OC, 5V/OCR, 9V/OC: Intrinsically safe line driver and open collector outputs. These drivers are specific to intrinsically safe encoders, and are installed per the appropriate control drawings listed in Table 2.1 on page 48 of the 2008 BEI Spec Guide.

6. Special -S at the end of the model number is used to define a variety of non-standard features such as special shaft lengths, voltage options, or special testing. Please consult the factory to discuss your special requirements.

7. Higher frequency response may be available. Please consult with the factory.

8. Extended temperature ratings are available in the following ranges:

-40 to 70°C, -40 to 85°C, -20 to 105°C and -40 to 105°C depending on the particular model. Some models can operate down to -55°C. Extended temperature ranges can affect other performance factors. Consult with factory for more specific information.

9. Mating straight plug receptacles may be ordered from the factory:

For M12 use MS3116F12-10S, For M14 use MS3106F14S-6S
For M14/19 use MS3116J14-19S, For M16 use MS3106F16S-1S
For M18 use MS3106F18-1S, For M20 use MS3106F20-29S