



Current-Mode PWM Controller with Supervisor

Features

- Synchronous Forward, Forward, and Flyback
- Lowest External Parts Count, Smallest Magnetics
- Eliminates Bootstrap Transformer Winding
- Supervisor Circuit Reduces Output Capacitance* up to 40%
- Supervisor Circuit Functions as μP WATCHDOG
- 15V to 250V Start-Up Regulator with START/STOP Control
- $<1\text{mA}$ Operating, $<6\mu\text{A}$ Standby Input Current
- V_{DD} Powered Operation down to 2.9V
- Charge Pump Voltage Multiplier Gate Drive Supply
- Compatible with Logic Gate MOSFETs at $V_{\text{DD}} = 3.3\text{V}$
- Compatible with Standard Gate MOSFETs at $V_{\text{DD}} = 5\text{V}$
- Programmable Soft Start
- $<50\%$ Duty Cycle Operation
- 15KHz to 350KHz Fixed Frequency PWM Operation
- Fault Tolerant Peer-to-Peer Synchronization
- Precision $\pm 1\%$ Band Gap Voltage Reference
- Precision $\pm 4\%$ Current Limit
- Current Sense Leading Edge Blanking
- Fast Over Current Shutdown
- Small SSOP-20 Footprint

* For short duration line loss, supervisor disables soft start if output within tolerance when V_{IN} returns and thus reduces holdup requirements.

General Description

The HV9606 PWM controller allows the design of high efficiency ($>90\%$) power supplies for distributed board mounted power (BMP) applications. Its high frequency capability provides high currents (20A @ 3.3V) with small transformers and its low internal operating voltage and current is capable of achieving high efficiencies in low power applications.

The HV9606 utilizes fixed frequency current mode control with duty cycle internally limited to $<50\%$. It supports both isolated and non-isolated topologies and provides all the necessary functions to implement a flyback, forward or synchronous forward converter with a minimum of external parts. The low V_{DD} operation of the HV9606 eliminates the bootstrap magnetic winding in non-isolated topologies. An on chip charge pump generates the gate drive voltage for driving an external N-channel MOSFET and eliminates the need for clamping by offering 250V immunity to high voltage transients common in telecom and network systems.

(continued on back page)

Applications

- Powered Ethernet and VoIP Terminals
- Cable Modems and Amplifiers
- ISDN Network Terminations, Terminals and Adapters
- Network Equipment
- Servers, PCs and Peripheral Equipment
- Telecommunication Systems and Terminals
- Distributed Board Mounted Power
- Battery Backup Systems
- Portable Power Applications
- Automotive and Heavy Equipment

Typical Application Circuit

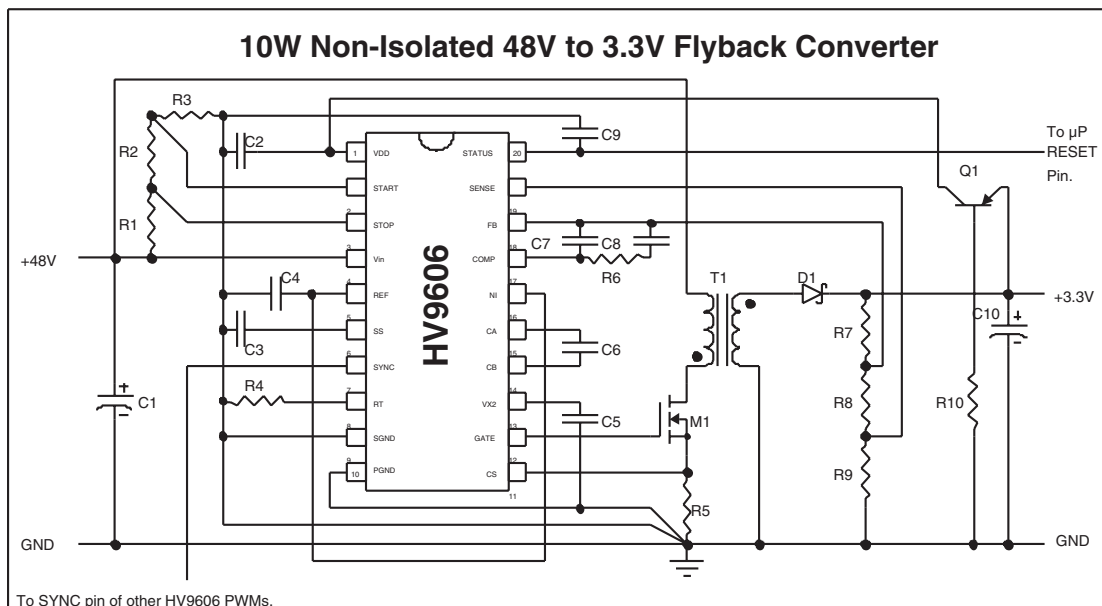

03/05/02

Supertex Inc. does not recommend the use of its products in life support applications and will not knowingly sell its products for use in such applications unless it receives an adequate "products liability indemnification insurance agreement." Supertex does not assume responsibility for use of devices described and limits its liability to the replacement of devices determined to be defective due to workmanship. No responsibility is assumed for possible omissions or inaccuracies. Circuitry and specifications are subject to change without notice. For the latest product specifications, refer to the Supertex website: <http://www.supertex.com>. For complete liability information on all Supertex products, refer to the most current databook or to the Legal/Disclaimer page on the Supertex website.

Electrical Characteristics (-40°C ≤ T_A ≤ +85°C unless otherwise noted)

Symbol	Parameter	Min	Typ	Max	Units	Conditions
--------	-----------	-----	-----	-----	-------	------------

Pre-Regulator Startup

V _{IN}	Regulator input voltage	15		250	V	
I _{IN}	Input leakage current			6	mA	V _{IN} = 20V, Start = 0V, Stop = 0V
I _{IN}	Input leakage current			50	mA	V _{IN} = 250V
I _{START}	Pre-regulator start-up current	5			mA	V _{IN} = 15V, Start & Stop 10M to V _{IN}
V _{DD(REG)}	Regulator output voltage	2.8	2.9	3.0	V	V _{IN} < 120V
UVLO _{VDD}	V _{DD} Under voltage lockout threshold	2.7	2.8	2.9	V	V _{DD} rising
UVLO _{VDD}	V _{DD} Under voltage lockout hysteresis	100		200	mV	

Supply (Test Condition: 0.1mF CA to CB and 0.1μF VX2 to PGND)

V _{DD}	Operating range	2.9		5.5	V	
I _{DD}	Supply current		1.0	1.5	mA	GATE open, f _{OSC} = 50KHz, V _{DD} = 3.3V
V _{VX2}	Gate drive charge pump supply	1.8 × V _{DD}			V	
UVLO _{VX2}	VX2 Under voltage lockout threshold	4.5			V	
UVLO _{VX2}	VX2 Under voltage lockout hysteresis		0.4		V	

Start/Stop Control

V _{START}	Start threshold	6.44	7.00	7.56	V	V _{IN} rising
V _{STOPR}	Stop threshold on rising V _{IN}	13	14	15	V	V _{IN} rising, V _{START} = 0V
V _{STOPF}	Stop threshold on falling V _{IN}	6.44	7.00	7.56	V	V _{IN} falling, V _{START} = 0V
I _{START}	Start input current			50	nA	
I _{STOP}	Stop input current			50	nA	

MOSFET Driver Output (Test condition: V_{VX2} = 5V)

V _{GATE(HIGH)}	Output high voltage	V _{VX2} -0.2			V	I _{GATE} = 10mA
V _{GATE(LOW)}	Output low voltage			0.15	V	I _{GATE} = -10mA
t _R	Rise time		30	50	nSec	C _{LOAD} = 250pF
t _F	Fall time		30	50	nSec	C _{LOAD} = 250pF

Charge Pump

f _{OSC}	Initial accuracy		10		%	
f _{OSCRANGE}	Oscillator Frequency Range	30		800	kHz	
T _C	Temperature coefficient		100	300	PPM/°C	f _{OSC} = 100 KHz
Δf/f	Voltage stability		1	2	%	f _{OSC} = 100 KHz, 2.9V V _{DD} 5.5V

SYNC

I _{OSYNC}	Sync output current		10	20	mA	
I _{ISYNC}	Sync input current	10			mA	V _{SYNC} < 0.1 Volt
I _{VSYNC}	Sync input voltage absolute limits	-0.5		V _{DD} +0.5	V	

PWM

F _{PWM}	PWM Oscillation Frequency	15		400	kHz	F _{PWM} = f _{OSC} /2, Stability as f _{OSC} above
D _{MAX}	Maximum duty cycle			49.99	%	f _{OSC} = 30KHz
D _{MAX}	Maximum duty cycle	49			%	f _{OSC} = 800KHz
D _{MIN}	Minimum pulse width before pulse drop out		130	195	nSec	V _{DD} = 3.3V
D _{MIN}	Minimum duty cycle			0	%	V _{FB} > V _{NI} , V _{SS} > 2V
D _{MIN}	Minimum duty cycle			0	%	V _{FB} < V _{NI} , V _{SS} 0.1V

Electrical Characteristics, continued $(-40^{\circ}\text{C} \leq T_A \leq +85^{\circ}\text{C}$ unless otherwise noted)

Symbol	Parameter	Min	Typ	Max	Units	Conditions
--------	-----------	-----	-----	-----	-------	------------

Reference

V_{REF}	Reference output voltage		1.2402		V	$T_A = 25^{\circ}\text{C}$, 2.4V V_{DD} 5.5V
V_{REF}	Reference output voltage tolerance			1.0	%	$T_A = 25^{\circ}\text{C}$, 2.4V V_{DD} 5.5V
V_{REF}	Reference output voltage tolerance			2.0	%	-40°C T_A 85°C , 2.4V V_{DD} 5.5V
V_{REF}	Load regulation		2.0	5.0	mV	$0 < I_{REF} < 0.1\mu\text{A}$
V_{REF}	Line regulation		2.0	5.0	mV	2.4V V_{DD} 5.5V
$I_{REF(SHORT)}$	Short circuit current			3.0	mA	$V_{REF} = \text{GND}$

Current Sensing (Test conditions: $V_{DD} = 3.3\text{V}$)

V_{CS}	Usable control current sense range	0		0.59	V	
V_{CS}	Current limit threshold	$0.48V_{REF}$	$0.50V_{REF}$	$0.52V_{REF}$	V	
V_{CS}	Leading edge current sense blanking time		85		nSec	
t_{DELAY}	Current limit delay to output		70	120	nSec	$V_{CS} = 0$ to 1V step after blanking time

Error Amplifier (Test conditions: 2.9V V_{DD} 5.5V)

I_{FB} or I_{NI}	Input bias current		25	200	nA	$V_{FB} = 1.5\text{V}$, $V_{NI} = 1.5\text{V}$
$V_{FB} - V_{NI}$	Input offset voltage			± 3.0	mV	$V_{FB} = V_{COMP}$, $V_{NI} = 1.5\text{V}$
V_{CM}	Common mode input range	0		$V_{DD} - 0.1$	V	
A_{VOL}	Open loop voltage gain	65			dB	
BW	Unity gain bandwidth	1.0			MHz	
I_{SOURCE}	Output current sourcing		2.0	1.0	mA	$V_{FB} < V_{NI}$
I_{SINK}	Output current sinking	-100			mA	$V_{FB} > V_{NI}$
V_{COMP}	Output voltage range	0		$V_{DD} - 0.7$	V	
PSRR	Power supply rejection	50			dB	

Soft Start

$V_{SS(LOW)}$	Soft start low output			0.1	V	$V_{DD} = 2.9\text{V}$, $V_{SENSE} = 0\text{V}$, $V_{CS} = 2.9\text{V}$
$V_{SS(HI)}$	Soft start high output	2.5		V_{DD}	V	$V_{DD} = 2.9\text{V}$, $V_{SENSE} = 2.9\text{V}$, $V_{CS} = 2.9\text{V}$
$I_{SS(HI)}$	Soft start output current		10	20	mA	$V_{DD} = 2.9\text{V}$, $V_{SENSE} = 2.9\text{V}$, $V_{CS} = 2.9\text{V}$
t_F	Soft start output fall time			10	mSec	$C_{SS} = 0.1\mu\text{F}$

Status Output (Test conditions: 2.7V V_{DD} 5.5V)

I_{SINK}	Output current sinking	5.0	10		mA	
I_{SOURCE}	Output current sourcing		10	20	μA	
$V_{STATUS(HIGH)}$	High output voltage	$V_{DD-0.1}$		V_{DD}	V	No load
$V_{STATUS(LOW)}$	Low output voltage		0.1	0.2	V	Sinking 2mA
$V_{SENSE(THLH)}$	Sense input threshold for rising input	$0.85V_{REF} + 0.050$	$0.85V_{REF} + 0.075$	$0.85V_{REF} + 0.100$	V	$V_{STATUS} = \text{LOW to HIGH transition}$
$V_{SENSE(THHL)}$	Sense input threshold for falling input	$0.85V_{REF} + 0.050$	$0.85V_{REF} + 0.075$	$0.85V_{REF} + 0.100$	V	$V_{STATUS} = \text{HIGH to LOW transition}$
$V_{SENSE(HYST)}$	Sense input hysteresis	100	150	200	mV	

Absolute Maximum Ratings*

V_{IN} Input Voltage	-0.3V to +250V
Supply Voltage, V_{DD}	-0.3V to +6V
Gate Drive Supply Voltage, $VX2$	-0.3 to +15V
Operating Ambient Temperature Range	-40°C to +85°C
Storage Temperature Range	-65°C to +150°C
Power Dissipation @ 25°C, SSOP	750mW
Power Dissipation @ 25°C, Plastic DIP	750mW

* All voltages referenced to SGND and PGND pins.

Ordering Information

Package Options	
20 Pin SSOP	Die
HV9606SP	HV9606X

Pinout

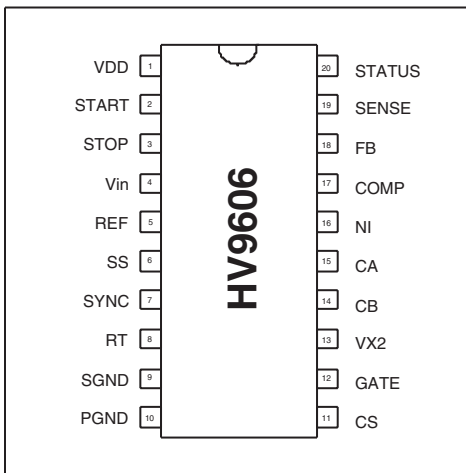

Pin Description

V_{DD} – This is the supply pin for the PWM Logic and Analog circuits. When the input voltage to the V_{IN} pin exceeds the start voltage the input regulator seeks to regulate the voltage on the capacitor connected to this pin to a nominal 2.9V. After the PWM has started, the bootstrap supply will regulate this voltage to a nominal 3.3V or 5V. With V_{IN} connected to PGND the circuit can be powered via this pin in the voltage range of 2.9V to 5.5V with a nominal 2.8V UVLO.

START – The resistive divider from V_{IN} sets the start-up regulator start voltage.

STOP – The resistive divider from V_{IN} sets the start-up regulator stop voltage. A low power sleep mode function may be implemented by pulling this pin to SGND.

V_{IN} – This is the startup linear regulator input. It can accept DC input voltages in the range of 15V to 250V. With START and STOP programmed to more than 20V, the leakage current on this pin is less than 6 μ A at $V_{IN} = 20V$.

VREF – This pin provides a 1% tolerance reference voltage.

SS – A capacitor connected to this pin determines the soft start time. Soft start may be initiated by a low $VX2$ voltage or an over current condition when the supervisor circuit STATUS output is low. During short duration input interruptions when the output voltage does not decay below programmed limits, the supervisor circuit inhibits soft start to permit rapid recovery of the system.

SYNC – This I/O pin may be connected to the SYNC pin of other HV9606 circuits and will cause the oscillators to lock to the highest frequency oscillator. Synchronization to a master clock is possible by means of an open collector or open drain logic gate or optocoupler provided the low duty cycle does not exceed 50%. If synchronization is utilized then a pull up resistor to V_{DD} is required to overcome the effects of parasitic capacitance on the circuit board. The value of the resistor required will depend on the operating frequency and master clock duty cycle.

RT – The resistor connected from this pin to SGND sets the frequency of the internal oscillator by setting the charging current for the internal timing capacitor. The PWM output frequency is one half the oscillator frequency.

SGND – Common connection for all Logic and Analog circuits.

PGND – Common connection for Gate Driver circuit.

CS – This is the current sense input. Under normal operation the over current limit is triggered when the voltage on this pin exceeds $0.5V_{REF}$, however, current sensing is blanked during the first 85ns on time of the MOSFET to prevent false triggering during the turn on switching transition. The loop control operating peak current sense may be set to any level below $0.5V_{REF}$.

GATE – This push-pull CMOS output is designed to drive the gate of an N-Channel power MOSFET.

$VX2$ – This is the supply pin for the Gate Driver circuit and is generated by the Charge Pump V_{DD} voltage multiplier circuit. It should be bypassed to PGND with a capacitor, typically 0.1mF.

CA and CB – The charge pump circuit uses a capacitor (typically 0.01 μ F) connected between these pins to generate the $VX2$ voltage.

NI – High impedance non-inverting input of the error amplifier.

COMP – The output of the error amplifier.

FB – High impedance inverting input of the error amplifier.

SENSE – This is the input pin to the supervisory circuit. On a rising input voltage the circuit changes state at a nominal $0.85V_{REF} + 0.075V$. When the input voltage is decaying the circuit changes state a nominal $0.85V_{REF} - 0.075V$.

STATUS – This is the output of the supervisory circuit. When the sense-input voltage is high, this output is pulled up to V_{DD} by a 10mA current source and the Soft Start function is disabled. When the sense-input is low, this output is pulled low and it may be used to directly control the reset of a microprocessor or it may be used to drive an optocoupler or LED indicator.

Functional Block Diagram

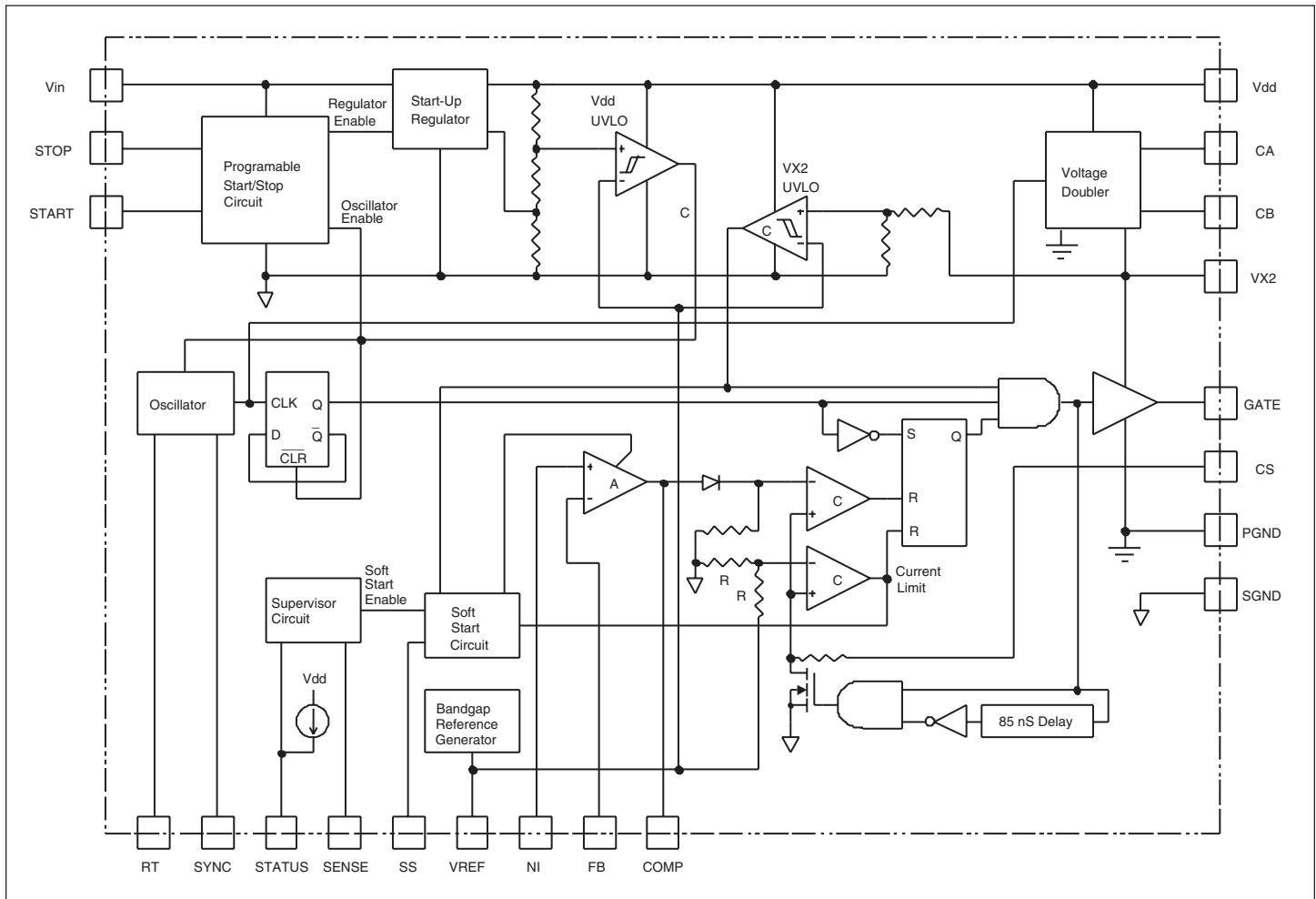

Functional Description

The HV9606 is made up of several functional blocks. The operation of each of these blocks is described in the following sections.

Programmable Start/Stop Control Circuit

In applications such as Powered Ethernet and Pair Gain, power is fed from a remote source over data-carrying wire pairs. For various reasons each of these systems require that below some voltage level on the line, the load shall appear as a very high impedance. In all of these systems the leakage current at some voltage level is specified. Start control provides this function by holding the circuit in a high input impedance state until the input voltage exceeds the programmed START threshold.

Since these systems provide power feed over the data wire pairs, the input supply source impedance to the DC/DC converter can be significant, from tens to hundreds of ohms. This creates a significant problem since the open circuit voltage may be sufficient to exceed the programmed START voltage, but as soon as the DC/DC converter begins to draw current, the voltage drop due to the resistance of the wire pairs significantly reduces the effective voltage.

Let us consider a specific application situation where the maximum loop resistance of the wire pair is 20Ω , the minimum open circuit voltage is $40V$, the maximum open circuit voltage is $60V$, the maximum allowable current is $500mA$ and the minimum current is $5mA$. From these conditions it is evident that the

effective voltage range at the input of the DC/DC converter is $30V$ to $59.9V$. The minimum power available at the input of the DC/DC converter is $30V \times 500mA$ or $15W$. Therefore, if the DC/DC converter is required to deliver a guaranteed maximum $12.5W$ at its output then its efficiency must be at least 84% .

Based on the above application conditions it is evident that the DC/DC converter cannot be allowed to start until the effective voltage exceeds $40V$ and must stop when the effective voltage drops below $30V$. If we impose an additional constraint that at $20V$ open circuit voltage on the wire pair, the resistor divider cannot draw more than $1\mu A$ the values for the $R1$, $R2$ and $R3$ resistor divider can be calculated as follows, since the input current on the start and stop pins is negligible.

$$V / I = 20V / 1\mu A = R1 + R2 + R3 = 20M\Omega$$

$$V_{START} / V_{IN} = 7V / 40V = R3 / (R1 + R2 + R3) = R3 / 20M\Omega$$

$$R3 = 20M\Omega \times 7V / 40V$$

$$R3 = 3.5M\Omega$$

$$V_{STOP} / V_{IN} = 7V / 30V = (R2 + R3) / (R1 + R2 + R3)$$

$$V_{STOP} / V_{IN} = (R2 + 3.5M\Omega) / 20M\Omega$$

$$R2 = (20M\Omega \times 7V / 30V) - 3.5M\Omega$$

$$R2 = 1.17M\Omega$$

And

Functional Description, continued:

$$R1 = 20M\Omega - R2 - R3 = 20M\Omega - 1.17M\Omega - 3.5M\Omega$$

$$R1 = 15.33M\Omega$$

The programmable start/stop control circuit was designed to provide this function. It inhibits the internal regulator, shuts down the oscillator and holds the PWM reset until the programmed start input voltage is exceeded. If the circuit is operating and the effective input voltage drops below the programmed stop threshold the internal regulator is inhibited, the oscillator is shut down and the PWM is reset.

Start-Up Regulator

The start-up regulator guarantees a maximum V_{IN} pin leakage current of $6\mu A$ at 20V at the V_{IN} pin while it is inhibited by the START/STOP circuit. When the effective input voltage exceeds the programmed START voltage, the regulator is turned on and seeks to provide a nominal 2.9V at the V_{DD} pin, which is the supply voltage for all internal circuitry within the HV9606 except the start/stop circuit. This regulator is capable of input voltages up to 250 Volts, which is the typical maximum arrester voltage limit used to provide protection on telephone wires. Due to the high voltage rating of the regulator the HV9606 can be used for applications operating from rectified AC mains up to 140Vrms. The regulator can supply a minimum of 5mA, which is sufficient to power the internal circuitry and provide gate drive power for the external MOSFET until the bootstrap circuit from the output of the PWM drives the voltage on the V_{DD} pin higher than the regulator set point. This forces the regulator to turn off and reduce the input current at the V_{IN} pin to leakage levels. The V_{DD} pin is typically bypassed with a capacitor of at least $1\mu F$, which provides the peak currents required by the voltage doubler and in turn the gate driver for the external MOSFET.

For low power applications the circuit may be operated without bootstrapping. Care should be taken to assure that the power dissipation in the regulator does not become excessive, as it might be if the input voltage is high and the gate drive energy required is high (operating at high frequency).

It is also possible to use the HV9606 by powering V_{DD} from supply voltages of 2.9V to 5.5V. In these applications the V_{IN} pin should be connected to SGND pin and the START and STOP pins may be connected to SGND pin or left open. In this application the START/STOP control and start-up regulator circuits are not used.

V_{DD} Under Voltage Lockout

To guarantee correct operation, internal circuitry is held reset by an under voltage lockout (V_{DD} UVLO) until the regulator output voltage is at least 100mV below the regulation set point. To guarantee stable starting the V_{DD} UVLO has a hysteresis of 100mV.

Oscillator

The oscillator circuit operates at twice the PWM output frequency. The frequency can be programmed in the range of 30KHz to 800KHz by means of a single resistor connected from the RT pin to SGND.

Synchronization

The SYNC pin is an input/output (I/O) port to a unique fault tolerant peer-to-peer and/or to master clock synchronization circuit. For synchronization the SYNC pins of multiple HV9606 based converters can be connected together and may also be connected to the open drain/collector output of an external

master clock. When connected in this manner the oscillators will lock to the device with the highest operating frequency. The LOW duty cycle of an external master clock should not exceed 50%. When synchronized in this manner, a permanent logic HIGH or LOW condition on the SYNC pin will result in a loss of synchronization, but the HV9606 based converters will continue to operate at their individually set operating frequency. For this reason the SYNC pin is considered fault tolerant, since loss of synchronization will not result in total system failure.

Depending on the cumulative parasitic capacitance on the SYNC pin when connected in the above manner a pull up resistor may be required from the SYNC pin to the V_{DD} pin on each HV9606 based DC/DC converter circuit. The value of the resistor will depend on the cumulative parasitic capacitance and operating frequency.

Voltage Doubler

The HV9606 can operate on internal voltages ranging from 2.9V to 5.5V. It may be difficult to find power MOSFETs capable of operating with such low gate drive voltages. For this reason the HV9606 incorporates a voltage doubler circuit that generates a voltage on the VX2 pin that is approximate two times the V_{DD} voltage. This circuit uses capacitive charge transfer methods and requires the connection of a capacitor (typically 0.01mF) between the CA and CB pins as well as an energy storage capacitor (typically 0.1mF) connected from the VX2 pin to PGND pin. The voltage doubler operates at the PWM output frequency.

The gate driver output on the GATE pin operates from the VX2 voltage, logic level (5V) gate power MOSFETs may be used when V_{DD} is bootstrapped at 3.3V or standard (10V) gate MOSFETs may be used when V_{DD} is bootstrapped at 5V.

VX2 Under Voltage Lockout

To guarantee that sufficient gate drive voltage is available, an under voltage lockout circuit (VX2 UVLO) monitors the VX2 voltage. If the VX2 voltage drops below 4.5V the gate driver output of the PWM circuit is inhibited to prevent damage to the power MOSFET. This under voltage lockout has a hysteresis of 400mV to prevent spurious operation.

Band Gap Reference

The operating limits of all internal circuits, except the START/STOP circuit, are based on the 1% tolerance band gap reference voltage available on the REF pin. It is capable of delivering 100mA for use by external circuitry without degrading the reference.

Current Sense and Current Limit

Current sensing is accomplished by means of a resistor connected in series with the source of the external power MOSFET. There are two independent comparators monitoring the voltage drop across this resistor. One provides absolute peak current limiting at 0.5VREF and the other provides peak current feedback to the PWM control loop.

Gate charge and capacitive loading reflected to the drain of the power MOSFET results in high current spike at the positive leading edge of gate drive when the MOSFET is turning on. This can result in false tripping of the current limit comparator or false operation of the control loop. To prevent this condition an 85nSec leading edge current sense blanking circuit is incorporated in the HV9606. This blanking period is sufficient in most applications to achieve stable operation. However, additional filtering of the MOSFET turn on current spike may be added by connecting a resistor in series with the (CS) current sense pin and a capacitor from the current sense pin to SGND pin.

Functional Description, continued:

Error Amplifier

The error amplifier has a minimum gain bandwidth of 1MHz. The inverting and non-inverting inputs are available respectively at FB and NI pins and the amplifier output is available at the COMP pin. Maximum application flexibility is provided by having all terminals of the error amplifier available. The design of the error amplifier prevents its output from saturating to the high rail (V_{DD}) thus providing very fast slew recovery capability.

Soft Start Control Circuit

The soft start circuit provides a nominal constant current output of 10 μ A at the SS pin for charging a capacitor connected to this pin. The instantaneous voltage on the SS pin determines the high limit of the error amplifier, thus forcing the PWM to start at minimum output duty cycle and slowly increase the duty cycle until a stable closed loop operation is achieved. The value of the capacitor should be selected to achieve this stable closed loop operation before the voltage on the SS pin exceeds 1.2V at maximum output load on the DC/DC converter.

Soft start can only be initiated if the STATUS output of the SUPERVISOR circuit is low. The SS pin is pulled low, discharging the capacitor and engaging soft restart whenever the peak current sense limit is exceeded or the VX2 UVLO detects a low gate drive voltage.

PWM Circuit

The current mode PWM circuit operates at one half the oscillator frequency with a duty cycle guaranteed not to exceed 50%. Its minimum pulse width (typically 130nSec) provides a wide dynamic control range especially when operating at low frequencies.

For the dynamic control range required by a given application the maximum operating frequency can be determined using the following equations.

$$t_{ON} = (V_{IN(MAX)} / V_{IN(MIN)}) \times (P_{OUT(MAX)} / P_{OUT(MIN)}) \times D_{MIN}$$

$$f_{OSC} = 2 f_{PWM} < 1 / t_{ON}$$

Where t_{ON} is the maximum gate drive output on time, $V_{IN(MAX)}$ and $V_{IN(MIN)}$ are the maximum and minimum input voltage, $P_{OUT(MAX)}$ and $P_{OUT(MIN)}$ are the maximum and minimum output power, D_{MIN} is the worst case minimum gate drive output duty cycle (195nSec), f_{PWM} is the maximum gate drive switching frequency and f_{OSC} is the maximum oscillator frequency.

Supervisor Circuit

Designers may use this voltage monitor circuit for various applications. The supervisor circuit controls the function of the soft start circuit, which will be enabled when the STATUS output pin is in a low state. The STATUS output pin is low when the voltage on the SENSE pin is less than $0.85V_{REF} - 100mV$.

The supervisory circuit can be used to monitor the output voltage of the DC/DC converter. When used in this manner the STATUS output pin may be used as a WATCHDOG to reset a micro controller when ever its supply voltage decays to a programmed voltage level below which unpredictable operation may result. Using it in this manner in a non-isolated topology, where the output voltage is used for bootstrapping V_{DD} , it will inhibit soft start as long as the output is within programmed limits, thereby providing a rapid restart after a short duration input voltage dropout. This allows the minimization of both input and output capacitors for a given system hold up time requirement. In an isolated topology, sizing the V_{DD} capacitor for a hold up time greater than the output hold up time requirement will similarly permit the minimization of the input and output capacitors.

The supervisory circuit can also be used as a high accuracy low input voltage detection and inhibit circuit by connecting the STATUS pin to the SS pin. Since the status pin has a 10mA internal pull up it will double the charging current of the soft start capacitor, thus the soft start capacitor value needs to be doubled for the same soft start time. The SENSE pin may be connected through a resistor divider to any monitored voltage source (other than the output of the HV9606 based DC/DC converter) or to a logic output. When the voltage on the SENSE pin falls below the nominal threshold of $0.85V_{REF} - 75mV$, the SS pin will be pulled low, thereby inhibiting the gate drive output and shutting down the converter. The oscillator will operate even though the GATE output is held low and the SYNC I/O pin will maintain synchronization with other system components or provide a clock signal to the system.

Shut Down / Inhibit Operation

The HV9606 may be shut down or inhibited depending on the system requirements.

Pulling the STOP pin down to SGND will shut down the HV9606, placing it in a zero power (leakage only) mode where even the oscillator is halted. This pull down may be accomplished with a discrete MOSFET, an optocoupler, or the open drain/collector output of a logic gate with at least 20V breakdown rating. Using this shut down method will cause the SYNC pin to be pulled low, thus synchronization of other components connected to the SYNC line will be lost.

Provided the input voltage remains above the programmed stop threshold, inhibit of the PWM can be achieved by pulling the SS pin low to SGND, thereby forcing the gate drive output to a permanent low state and guaranteeing a soft restart when SS pin pull down is released. The internal start up regulator will power the HV9606 thus the oscillator will operate and the SYNC I/O pin will maintain synchronization with other system components or provide a clock signal to the system. This pull down could be accomplished with a discrete MOSFET, an optocoupler, or the open drain/collector output of a logic gate with at least a 5V breakdown rating.

Application Information

Typical Semi-Isolated ISDN Circuit

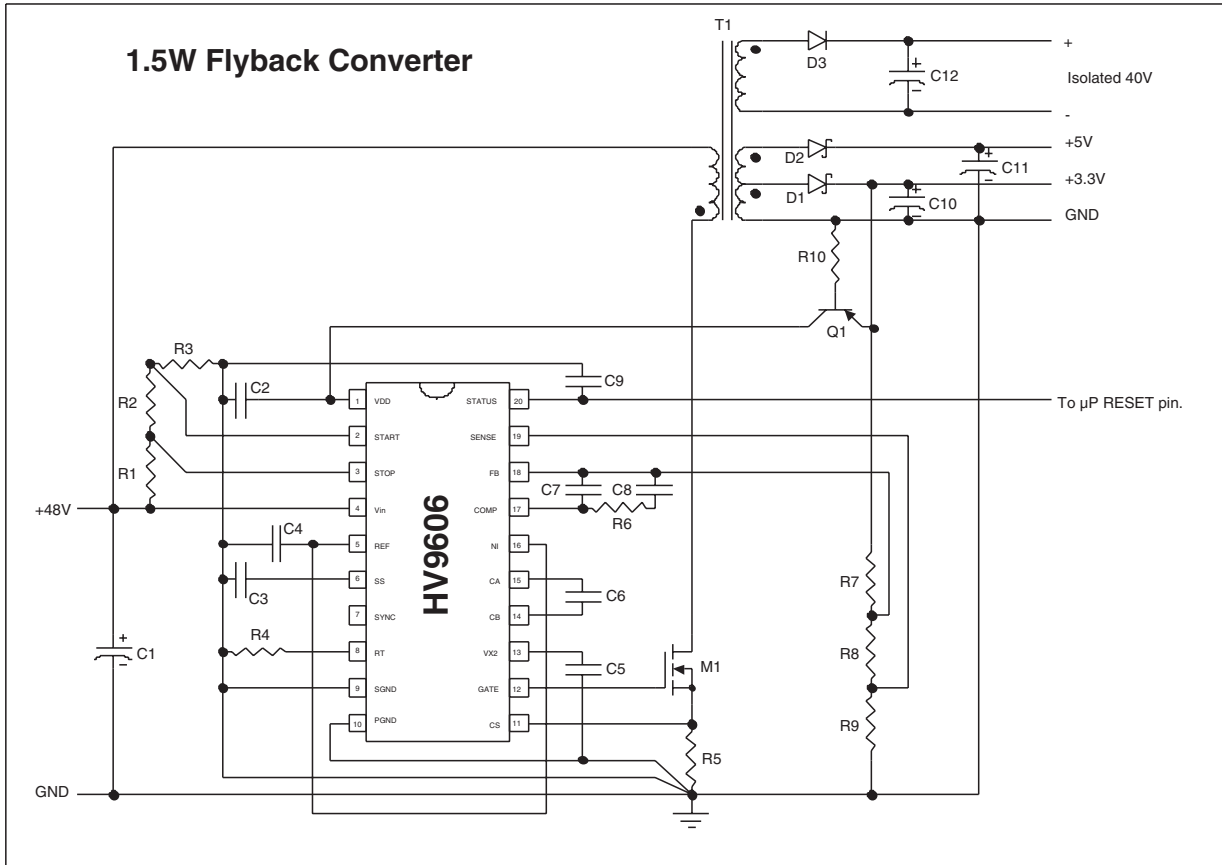

Typical Isolated ISDN Circuit

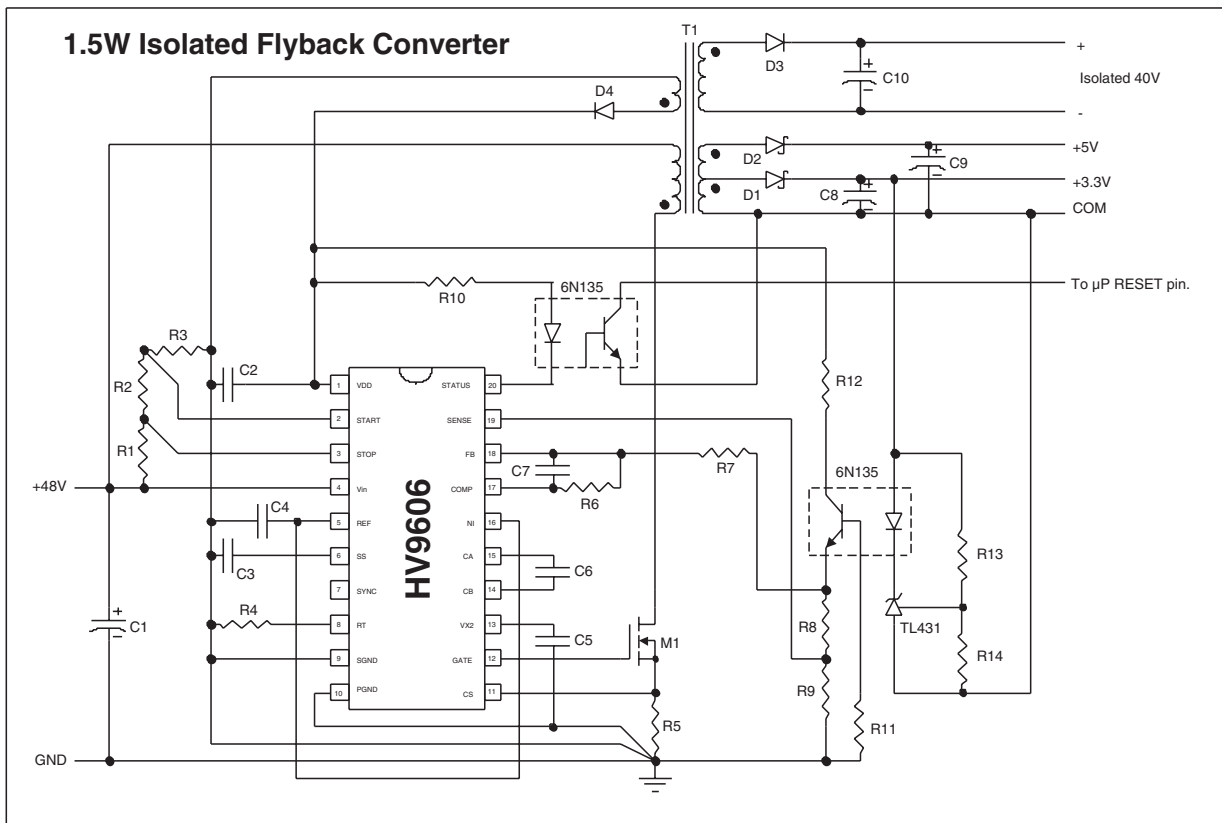

Application Information

Typical Board Mounted Power Synchronous Forward Converter

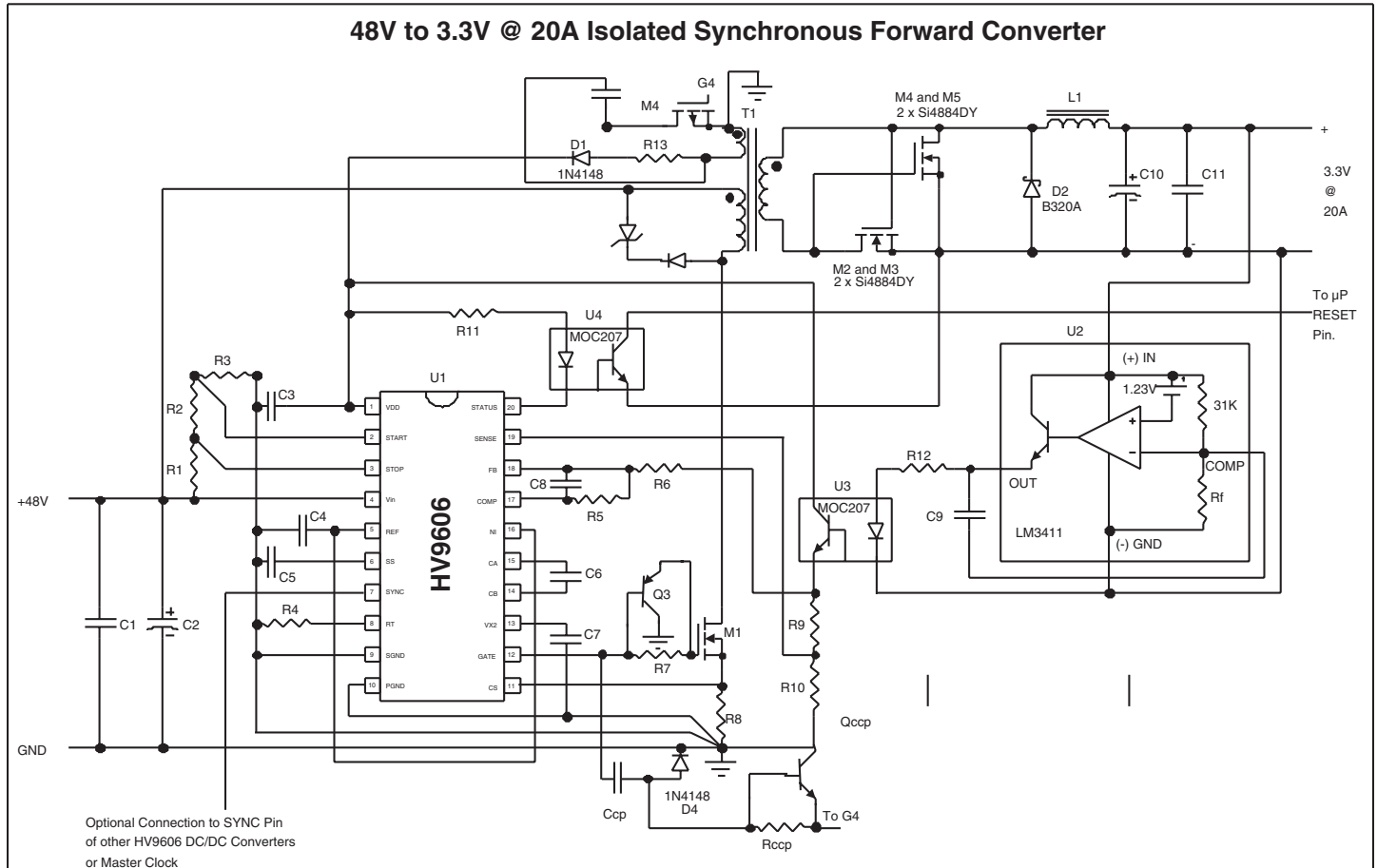

General Description, *continued from Page 1*

It conforms to the requirements of IEEE 802.3 Powered Ethernet and ETR-080 ISDN specifications.

The oscillator is programmable and provides fault tolerant peer-to-peer synchronization to other similar circuits or master clock. The chip draws almost no current ($<6\mu\text{A}$ @ $V_{\text{IN}} < 20\text{V}$) until the programmable START/STOP thresholds of the start-up regulator are satisfied. It can also be powered via the V_{DD} pin, rather than the V_{IN} pin, in the range of 2.9V to 5.5V.

Other functions include leading edge current sense blanking, programmable SOFT START, precision 1% band gap reference and a SUPERVISOR CIRCUIT. The SUPERVISOR can provide housekeeping functions such as μP supply monitoring and reset, soft start inhibit for rapid restart on short duration input voltage interruption. It also minimizes input and output capacitance requirements.