

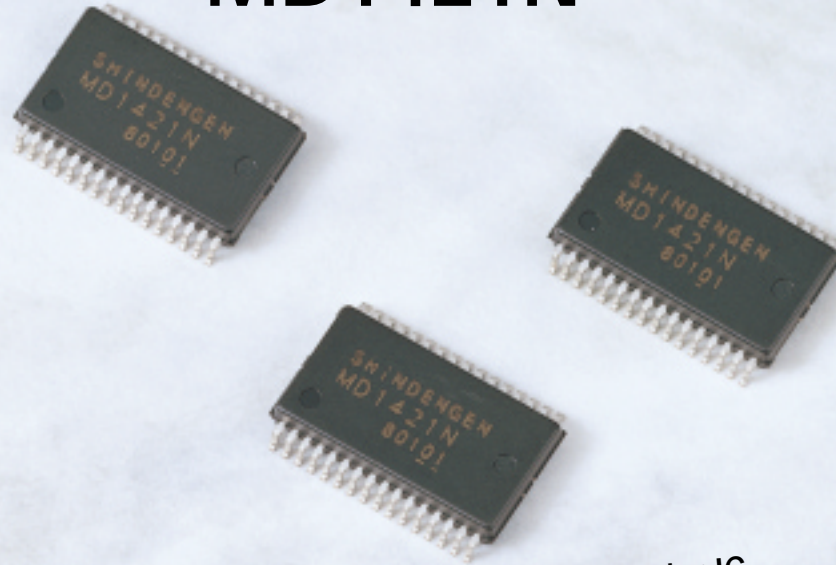

**NEW
PRODUCTS**

Synchronous Rectification DC to DC Converter Power IC MD1421N



3.3V/5V PWM Control Stepping Down Converter IC
Synchronous Rectification Method realizes High Output Power and High
Efficiency (typ. 95%) integrating high performance and high function in
compact package

Summary

MD1421N is a non-isolated, PWM control stepping down DC to DC converter power IC including main MOSFET switch and synchronous rectification MOSFET inside. It has maximum 15W (5V, 3A) output power and high efficiency in wide range. It also has wide input voltage range (8 - 40V) and it is possible to get 3.3V or 5V output voltage by selecting terminal. Its package is new compact surface mount type (SSOP-32) and it is possible to design DC to DC converter with fewer external components and smaller mounting area.

Feature

- Input Voltage range 8-40V
- Maximum Output Current 3A
- Included main MOSFET switch and synchronous rectification MOSFET
- Output 3.3V / 5V (Selective with output switching terminal)
- High Efficiency typ. 95% (at: Vin=8V, Vout=5V, Iout=1A)
- Fixed Frequency 250kHz PWM Control
- Over Current Protection Function
- Low Input Voltage Protection Function (UVLO)
- Thermal Shut Down Function
- Remote control On / Off function

SHINDENGEN
ELECTRIC MFG. CO., LTD.

Block Diagram

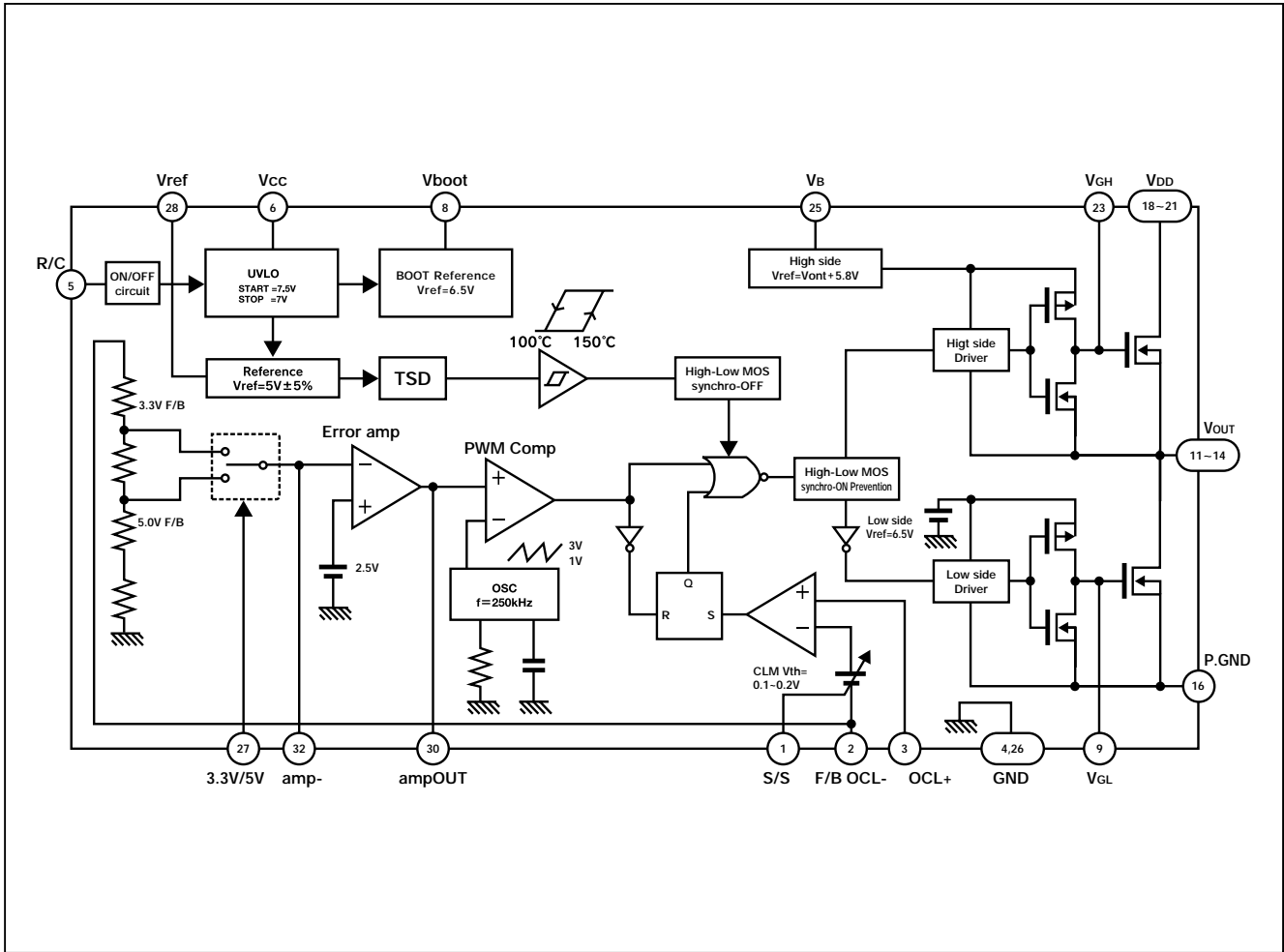

Application Example

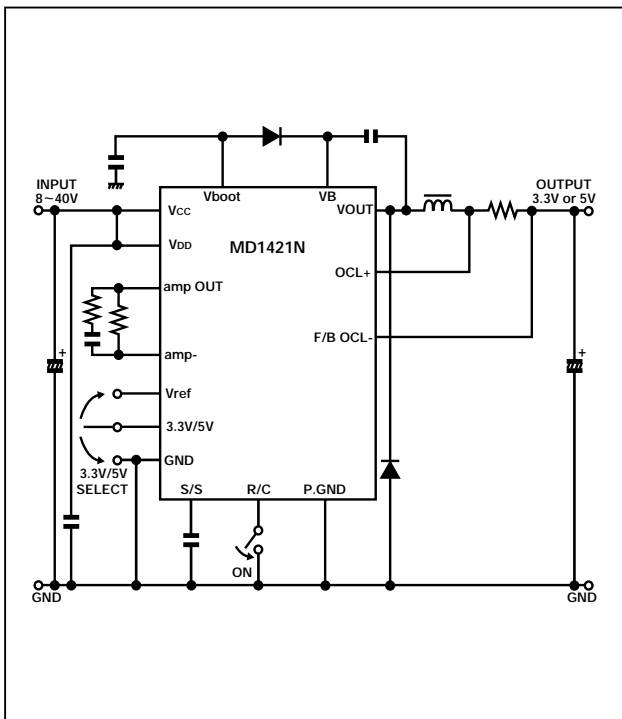

Pin Layout

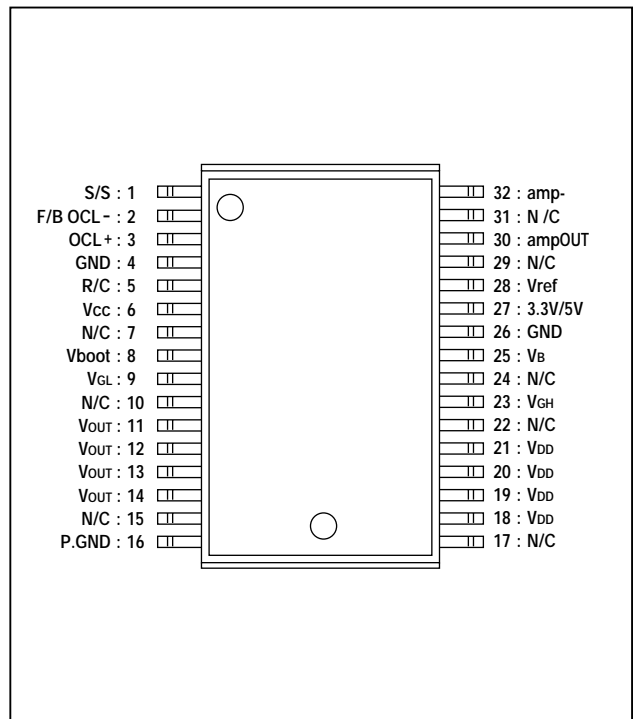

Absolute Maximum Ratings (Ta=25°C)

Item	Symbol	Rating	Unit
Line voltage	V _{IN}	42	V
Output MOS input voltage	V _{DD}	42	V
Output current (A V E)	I _{OUTave}	3	A
Output current (P E A K)	I _{OUTpeak}	4	A
Remote control voltage	V _{RC}	5.5	°C
Storage temperature	T _{stg}	-40~150	°C
Junction temperature	T _j	150	°C

Recommended Operation Conditions

Item	Recommended Value	Unit
Input voltage	8~40	V
Operation temperature	-10~80	°C

Electrical Characteristics (Ta=25°C)

Item	Symbol	Condition	MIN	TYP	MAX	Unit
HighsideMOS Drain-source breakdown voltage	V _{dss}	I _D =1mA, V _{GS} =0V	42	—	—	V
HighsideMOS Drain interruption current	I _{dss}	V _{DS} =40V, V _{GS} =0V	—	—	10	μA
HighsideMOS Drain-source ON resistance	R _{on}	I _D =1.2A, V _{GS} =4.5V	—	33	70	mΩ
HighsideMOS Source-drain Di forward voltage	V _{SD}	I _S =1.2A, V _{DS} =0V	—	—	1.5	V
LowSideMOS Drain-source breakdown voltage	V _{dss}	I _D =1mA, V _{GS} =0V	42	—	—	V
LowSideMOS Drain interruption current	I _{dss}	V _{DS} =40V, V _{GS} =0V	—	—	10	μA
LowSideMOS Drain-source ON resistance	R _{on}	I _D =1.2A, V _{GS} =4.5V	—	33	70	mΩ
LowSideMOS Source-drain breakdown voltage	V _{SD}	I _S =1.2A, V _{DS} =0V	—	—	1.5	V
Start voltage	V _{cc_start}	—	7	7.5	8	V
Stop voltage	V _{cc_stop}	—	6.5	7	7.5	V
Start-stop voltage hysteresis	V _{cc_hys}	—	—	0.5	—	V
Current consumption	I _{cc}	V _{cc} =8~40V	—	10	12	mA
Current consumption with remote control OFF	I _{cc_off}	V _{cc} =8V~40V	—	1.2	1.5	mA
Voltage with remote control terminal ON	V _{RC_on}	V _{cc} =8V~40V	-0.2	—	0.5	V
Voltage with remote control terminal OFF	V _{RC_off}	V _{cc} =8V~40V	2.5	—	5.3	V
Current with remote control terminals shorted	I _{rc}	V _{cc} =8V~40V	—	—	250	μA
BOOT terminal voltage	V _{boot}	V _{cc} =24V	6	6.5	7	V
Internal reference voltage	V _{ref}	V _{cc} =8V~40V	4.75	5	5.25	V
Internal oscillation frequency	f _{osc}	V _{cc} =24V	212.5	250	287.5	kHz
Overcurrent threshold voltage	V _{th_OCL}	V _{cc} =24V	0.162	0.19	0.218	V
SoftStart terminal current	I _{s/s}	V _{cc} =24V	-20	-12.5	-5	μA
"H" CHG terminal input voltage	V _{CHGH}	—	4.5	—	V _{ref}	V
"L" CHG terminal input voltage	V _{CHGL}	—	GND	—	0.5	V
Overcurrent protection operating temperature	T _{TSD}	—	—	150	—	°C

Outline Dimensions

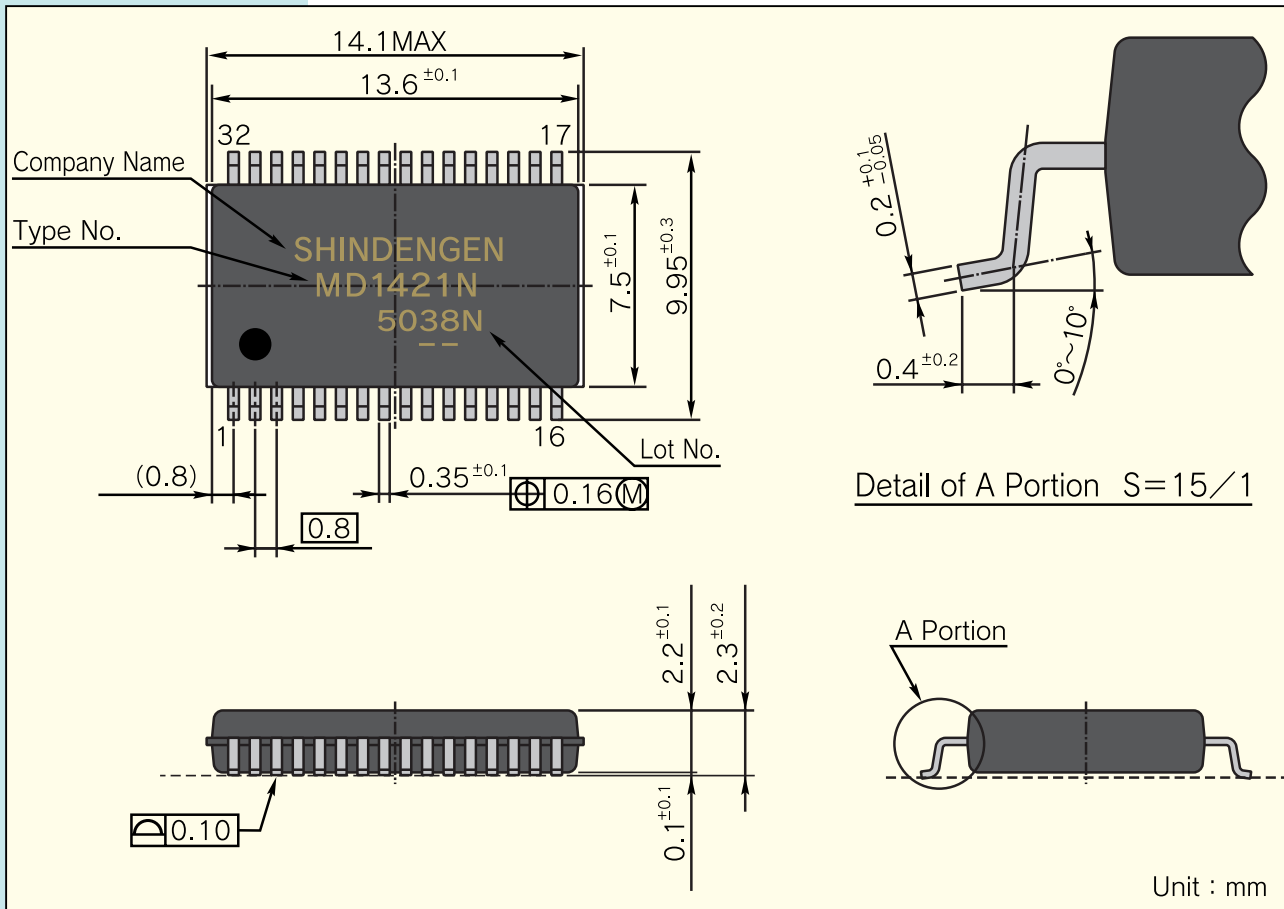

■ The level of quality of our products shown in this catalog is intended for use in standard applications requiring ordinary reliability. In the case these products are to be used in equipment or devices for special or specific applications requiring extremely high levels of quality and reliability in which failure or malfunction of a product may directly affect human life or health, always make sure to obtain confirmation by contacting our firm in advance. The quality levels of our products are classified in the manner shown below,

Standard Applications

Computers, OA and other office equipment, communication terminal equipment, measuring instruments, AV equipment, amusement equipment, home appliances, machine tools, personal equipment, industrial robots, etc.

Special Applications

Transportation equipment (automotive, marine, etc.), trunk line communication equipment, traffic signal equipment, fire prevention/anti-theft equipment, various safety devices, health care equipment, etc.

Specific Applications

Nuclear power control systems, aeronautical equipment, aerospace equipment, submarine relay equipment, devices and systems for preserving life, etc.

■ Although efforts are constantly made to improve quality and reliability, please select a product after careful examination so that personal injury, accidents and social damage can be prevented as a result of deploying measures such as a redundant design, designs that prevent the spreading of fire, designs that prevent malfunctions and so forth while taking safety into consideration as necessary.

* All specifications are subject to change without notice.

Please note that the information contained in this catalog may change for improvement or other purpose without notice.

Issued: October 2000

Export regulations of strategic materials, etc.

This product is classified as the integrated circuit specified in Item 7 in the Attached Table No. 1 to the Export Trade Control Order and in Article 6 of the Ordinance of the Ministry of International Trade and Industry.

This product is subject to the KNOW regulation.

October 2000

Shindengen America, Inc.

Head Office

2985 E. Hillcrest Drive, Suite 140
Westlake Village, CA 91362, U.S.A.
Phone: (1)-805-373-1130 Fax: (1)-805-373-3710

Chicago Office

411 Business Center Drive, Suite 112
Mt. Prospect, IL 60056 U.S.A.
Phone: (1)-847-827-7100 Fax: (1)-847-827-7122

Shindengen UK Ltd.

Howard Court, 12 Tewin Road,
Welwyn Garden City, Hertfordshire. AL7 1BW
Phone: (44)-1707-332-992 Fax: (44)-1707-332-955

German Representative Office

Kaiser-Strasse 25, D-40479 Dusseldorf, Germany
Phone: (49)-211-491968-0 Fax: (49)-211-4986499



SHINDENGEN
ELECTRIC MFG. CO., LTD.

Ikebukuro office:

RECRUIT Ikebukuro Bldg., 1-13-23, Minami-Ikebukuro,

Toshima-ku, Tokyo 171-0022, Japan

Phone : (81)-03-5951-8106

Fax : (81)-03-5951-8099