

L64780 DVB-T COFDM Demodulator

Technical Manual

February 2000

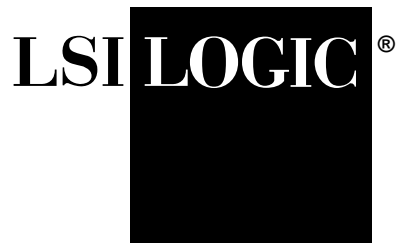

Order No. I14027

This document contains proprietary information of LSI Logic Corporation. The information contained herein is not to be used by or disclosed to third parties without the express written permission of an officer of LSI Logic Corporation.

Document DB14-000113-00, First Edition (February 2000)

This document describes LSI Logic Corporation's L64780 DVB-T COFDM Demodulator and will remain the official reference source for all revisions/releases of this product until rescinded by an update.

To receive product literature, visit us at <http://www.lsilogic.com>.

LSI Logic Corporation reserves the right to make changes to any products herein at any time without notice. LSI Logic does not assume any responsibility or liability arising out of the application or use of any product described herein, except as expressly agreed to in writing by LSI Logic; nor does the purchase or use of a product from LSI Logic convey a license under any patent rights, copyrights, trademark rights, or any other of the intellectual property rights of LSI Logic or third parties.

TRADEMARK ACKNOWLEDGMENT

The LSI Logic logo design and G10 are registered trademarks of LSI Logic Corporation. All other brand and product names may be trademarks of their respective companies.

Copyright © 1999, 2000 by LSI Logic Corporation. All rights reserved.

Preface

This book is the primary reference and technical manual for the L64780 DVB-T COFDM Demodulator. It contains a complete functional description as well as complete physical and electrical specifications for the LSI Logic L64780.

Audience

This document assumes you are familiar with digital video broadcasting, terrestrial television transmission and reception, modulation/demodulation, error control coding, digital signal processing, microprocessors, and related support devices. The people who benefit from this book are:

- engineers and managers evaluating the L64780 for use in a receiver for digital TV or cable data transmissions.
 - engineers designing the L64780 into a system.
-

Organization

This document has the following chapters and appendixes:

- [Chapter 1, Introduction](#), provides a brief overview of the L64780 and lists its features and benefits.
- [Chapter 2, Architectural Overview](#), describes the architecture of the L64780 and gives a functional description of its main components.
- [Chapter 3, Interfaces](#), describes the interfaces of the L64780 and gives a functional description of each.
- [Chapter 4, Register Descriptions](#), provides a description of the registers that determine the functionality of the L64780.

- [Chapter 5, Signal Descriptions](#), provides a description of the signals used and generated by the L64780.
- [Chapter 6, Specifications](#), describes the specifications for the L64780 electrical and mechanical characteristics.
- [Appendix A, Programming the L64780 Using The Serial Bus Interface](#), describes how to program the L64780 using the Serial Bus.

Related Publications

ETSI Specification ETS 300 744. 1997. "Digital broadcasting systems for television, sound and data services; Framing structure, channel coding and modulation for digital terrestrial television."

Stott, J.H., 1996. *The DVB Terrestrial (DVB-T) Specification and its Implementation In a Practical Modem*. International Broadcasting Convention 1996.

Conventions Used in This Manual

The word *assert* means to drive a signal true or active. The word *deassert* means to drive a signal false or inactive.

Hexadecimal numbers are indicated by the prefix "0x" (for example, 0x32CF). Binary numbers are indicated by the prefix "0b" (for example, 0b0011.0010.1100.1111).

Contents

Chapter 1	Introduction	
1.1	Overview	1-1
1.2	Using the L64780 in a Receiver	1-3
1.3	RF Tuner Block Functions	1-4
1.4	Modes of Operation	1-6
1.5	Features	1-6
1.6	Typical Performance	1-7

Chapter 2	Architectural Overview	
2.1	Demodulator Module Functional Description	2-2
2.2	Analog-to-Digital Converter (ADC)	2-4
2.3	Automatic Gain Control (AGC)	2-4
2.3.1	AGC Target RMS Value	2-4
2.3.2	AGC External Loop Filter	2-5
2.3.3	AGC Loop Gain K_s	2-6
2.4	Real-to-Complex Conversion	2-7
2.5	Fast Fourier Transform (FFT) Block	2-8
2.6	Time Synchronization	2-8
2.6.1	Timing Loop Gain	2-8
2.6.2	TIM_CLK_INIT Register Definition	2-9
2.6.3	TIM External Loop Filter	2-9
2.7	Automatic Frequency Control (AFC)	2-10
2.7.1	Analog Frequency Synchronization	2-10
2.7.2	Digital Frequency Synchronization	2-10
2.7.3	AFC Loop Gain	2-11
2.7.4	AFC_INIT_FREQ Register Definition	2-12
2.7.5	AFC External Loop Filter	2-12
2.8	TPS Decoding and Frame Synchronization	2-13
2.9	Mode Control Logic	2-14

2.10	Channel Estimation and Equalization	2-15
2.11	Viterbi Metric Assignment and Quantization	2-16
2.12	Symbol Deinterleaver	2-17
2.13	Bit Deinterleaver	2-17

Chapter 3

Interfaces

3.1	Output Interface	3-1
3.1.1	Output Format in Nonhierarchical Mode	3-1
3.1.2	Output Format in Hierarchical Mode	3-5
3.2	MUXIN Interface	3-8
3.2.1	Access to Timing and DDFS Blocks	3-10
3.2.2	Access to the AFC Block	3-10
3.2.3	Access to the FFT Block	3-11
3.2.4	Access to the CSI Block	3-11
3.2.5	Access to the SDI Block	3-12
3.3	MUXOUT Interface	3-13
3.3.1	DDFS Output	3-14
3.3.2	FFT Output	3-14
3.3.3	AFC Output	3-14
3.3.4	Channel Equalizer (CE) Output	3-15
3.3.5	CSI Output	3-15
3.3.6	ADC Output	3-16
3.4	Microprocessor Interface	3-16

Chapter 4

Register Descriptions

4.1	Memory Map	4-2
4.2	Interrupt Registers	4-7
4.2.1	Address Line 0x00	4-7
4.2.2	Interrupt Mask Register, Address Line 0x01	4-9
4.3	TPS Registers	4-11
4.3.1	Address Line 0x02	4-11
4.3.2	Address Line 0x03	4-12
4.3.3	Address Line 0x04	4-14
4.4	Parameter Registers	4-16
4.4.1	Address Line 0x05	4-16
4.4.2	Address Lines 0x06, 0x07, 0x08	4-19
4.4.3	Address Line 0x09	4-20

4.4.4	Address Line 0x0A	4-23
4.4.5	Address Line 0x0B	4-24
4.4.6	Address Line 0x0C	4-25
4.4.7	Address Line 0x0D	4-27
4.4.8	Address Line 0x0E	4-27
4.4.9	Address Lines 0x0F, 0x10	4-28
4.4.10	Address Line 0x11	4-29
4.4.11	Address Line 0x12	4-30
4.4.12	Address Line 0x13	4-31
4.4.13	Address Line 0x14	4-31
4.5	Mux Register Address Line 0x15	4-32
4.6	Performance Monitoring Registers Address Line 0x16	4-34
4.6.1	Address Line 0x17	4-35
4.6.2	Address Line 0x18	4-35
4.7	Mode Register Address Line 0x19	4-36
4.8	3-Wires Register Address Line 0x1A	4-38

Chapter 5

Signal Descriptions

5.1	Overview	5-1
5.2	Microprocessor Interface	5-3
5.3	Main Signals	5-4
5.4	Sigma-Delta Outputs	5-6
5.5	MUX Signals	5-6
5.6	3-Wires Signals	5-7
5.7	JTAG Signals	5-7
5.8	Test Pins	5-8
5.9	ASIC Pins	5-8
5.10	PLL Pins	5-8
5.11	Tester Pins	5-9

Chapter 6

Specifications

6.1	Electrical Specifications	6-1
6.2	AC Timing	6-4
6.2.1	Input Data Interface	6-4
6.2.2	Output Data Interface	6-5
6.2.3	Reset Timing	6-5
6.3	Signal Specifications	6-6

6.4	Pinouts	6-11
6.4.1	Pin List	6-11
6.4.2	Pin Layout	6-14
6.5	Mechanical Drawing	6-15

Appendix A Programming the L64780 Using The Serial Bus Interface

A.1	Serial Bus Protocol Overview	A-2
A.2	Programming the Slave Address Using the Serial Bus	A-3
A.2.1	Write Cycle Using the Serial Bus	A-3
A.2.2	Read Cycle Using the Serial Bus	A-4

Customer Feedback

Figures

1.1	Typical Terrestrial-Only Receiver	1-3
1.2	UHF Tuner Example	1-4
1.3	Receiver Architecture for Satellite and Terrestrial Reception	1-5
1.4	Performance with Additive White Gaussian Noise (AWGN)	1-7
1.5	DVB-T Carrier to Co-channel PAL-I Interference Ratio for Failure	1-8
1.6	Maximum Level of a Single Echo for Failure of QPSK, Rate 1/2, Guard Interval 7	1-8
2.1	DTTV Demodulator Architecture	2-3
2.2	Structure of 9-Bit AGC_TARGET Register	2-4
2.3	AGC Loop Pass Filter	2-5
2.4	External Low-Pass Loop Filter	2-9
2.5	AFC Loop Pass Filter	2-12
2.6	Scattered Pilot Structure	2-15
3.1	Output Interface in Nonhierarchical and Serial Modes	3-2
3.2	Nonhierarchical, Serial Mode, 64 QAM Constellation	3-2
3.3	Nonhierarchical, Serial Mode, 16 QAM Constellation	3-3
3.4	Nonhierarchical, Serial Mode, QPSK Constellation	3-3
3.5	Output Interface in Nonhierarchical and Parallel Modes	3-3
3.6	Nonhierarchical, Parallel Mode, 64 QAM Constellation	3-4
3.7	Nonhierarchical, Parallel Mode, 16 QAM Constellation	3-4

3.8	Nonhierarchical, Parallel Mode, QPSK Constellation	3-4
3.9	Output Interface in Hierarchical and Two FECs Modes	3-5
3.10	Hierarchical, Two FEC Decoders, 16 QAM Constellation	3-5
3.11	Hierarchical, Two FEC Decoders, 64 QAM Constellation	3-6
3.12	Output Interface in Hierarchical and One FEC Mode	3-6
3.13	Hierarchical, One FEC Decoder Mode With 16 QAM (HP or LP Selected) or 64 QAM (LP Selected only)	3-7
3.14	Hierarchical, One FEC Decoder Mode With 64 QAM (HP Selected Only)	3-7
3.15	MUXIN Signals Interface	3-8
3.16	Timing and DDFS Input Mapping	3-10
3.17	AFC Input Mapping	3-10
3.18	FFT Input Mapping	3-11
3.19	CSI Input Mapping	3-11
3.20	SDI Input Mappings	3-12
3.21	D[23:0] Bus Mapping in Three-Bit Soft Decision	3-12
3.22	D[23:0] Bus Mapping in Four-Bit Soft Decision	3-12
3.23	DDFS Output Mapping	3-14
3.24	FFT Output Mapping	3-14
3.25	AFC Output Mappings	3-14
3.26	CE Output Mappings	3-15
3.27	CSI Output Mappings	3-15
3.28	ADC Output Mapping	3-16
4.1	Graphical View of the L64780 Register Address Space 1	4-4
4.2	Graphical View of the L64780 Register Address Space 2	4-5
4.3	Graphical View of the L64780 Register Address Space 3	4-6
4.4	Interrupt Generation	4-9
5.1	L64780 Logic Symbol	5-2
6.1	Input Data AC Timing	6-4
6.2	Output Data AC Timing	6-5
6.3	Reset Timing	6-5
6.4	Package Pin Layout	6-14
6.5	160 PQFP Mechanical Drawing: Top and Side Views	6-15
6.6	160 PQFP Mechanical Drawing: Detail	6-16
A.1	Serial Bus Overview	A-2
A.2	General Call Address	A-3

Tables

2.1	Approximate and Exact Frequencies for Real to Complex Conversion	2-7
3.1	MUXINBUS Mapping	3-8
3.2	MUXIN Configuration	3-9
3.3	MUXOUT_select Word Definition	3-13
3.4	Mode Selection Using the P_S Input Signal	3-16
4.1	L64780 Registers and Internal Memory Map	4-2
4.2	DDFS Block Modes	4-21
4.3	MUXIN Signal Settings and MUXIN Clock	4-33
6.1	Absolute Maximum Ratings	6-1
6.2	Recommended Operating Conditions	6-2
6.3	DC Characteristics	6-2
6.4	Input Data AC Timing Parameters	6-4
6.5	Output Data AC Timing Parameters	6-5
6.6	Reset AC Timing Parameters	6-5
6.7	Signal Summary List	6-6

Chapter 1

Introduction

This chapter provides an overview of the LSI Logic L64780 DVB-T COFDM Demodulator. It also lists this chip's features and benefits, and provides an illustrated description of its typical performance. This chapter contains the following sections:

- Section 1.1, "Overview," page 1-1
 - Section 1.2, "Using the L64780 in a Receiver," page 1-3
 - Section 1.3, "RF Tuner Block Functions," page 1-4
 - Section 1.4, "Modes of Operation," page 1-6
 - Section 1.5, "Features," page 1-6
 - Section 1.6, "Typical Performance," page 1-7
-

1.1 Overview

The L64780 is part of a digital terrestrial television receiver for signals transmitted in accordance with the Digital Video Broadcasting-Terrestrial/European Telecommunications Standards Institute (DVB-T/ETSI) specification. These signals convey digital information using Coded Orthogonal Frequency Division Multiplexing (COFDM), as well as concatenated Reed-Solomon and convolutional forward error correction (FEC) techniques. This information payload takes the form of an MPEG-2 transport stream that conveys picture, sound, and data information. This MPEG-2 transport stream format is used also in related specifications for the transmission of digital television signals by satellite or cable.

The concatenated coding used in the DVB-T/ETSI specification is identical to that in the DVB-S specification for satellite transmissions. The FEC decoder can take the same form in receivers for satellite as well as terrestrial transmissions. Thus, the L64780 chip provides all the necessary demodulation functions *except* for FEC decoding, which is done by a separate chip, such as the L64724 or the L64705. The L64780 I/O format and pinouts simplify its connection to the L64724/L64705.

The DVB-T/ETSI specification incorporates many modes, providing a wide range of capacity/performance trade-off options. The L64780 demodulates all these modes.

Terrestrial transmission paths are prone to multipath, which can result in “ghosting” on analog television pictures. With conventional methods of digital transmission, multipath causes inter-symbol interference. This becomes increasingly problematic as the bit rate increases.

The DVB-T/ETSI specification uses a special form of modulation that uses Coded Orthogonal Frequency Division Multiplexing, which is well-suited to channels with significant multipath. It can tolerate signals with long delay and high relative amplitude. Consequently, the L64780 can accommodate natural multipath (from terrain, buildings, etc.) and it can be used in a Single Frequency Network (SFN). In an SFN, many transmitters operate on the same frequency with the same modulation (used in Digital Audio Broadcasting, which also uses COFDM).

In the frequency domain, multipath can be seen as channel frequency selectivity. COFDM applies concatenated FEC coding, then distributes the coded data over many carriers (1705 or 6817 in this case, depending on the mode). At the receiver, the frequency selectivity of the channel causes some carriers to be degraded or suppressed. However, the receiver can determine how much each carrier is affected by noise, then pass this information to the inner-code Viterbi decoder by means of soft-decision bits. This allows the Viterbi decoder to decode the data more efficiently. A second decoder, for the Reed-Solomon FEC, completes the process.

1.2 Using the L64780 in a Receiver

The L64780 provides those parts of a receiver for DVB-T signals that are exclusive to the terrestrial specification for COFDM demodulation and inner interleaving. This includes synchronization, channel-equalization, and derivation of channel-state information.

The combination of the LSI Logic L64780 and L64724 (or L64705) chips forms the core of a receiver design for DVB-T, supporting two possible approaches: exclusively DVB-T reception, and dual DVB-T/DVB-S reception (see [Figure 1.1](#)).

Figure 1.1 Typical Terrestrial-Only Receiver

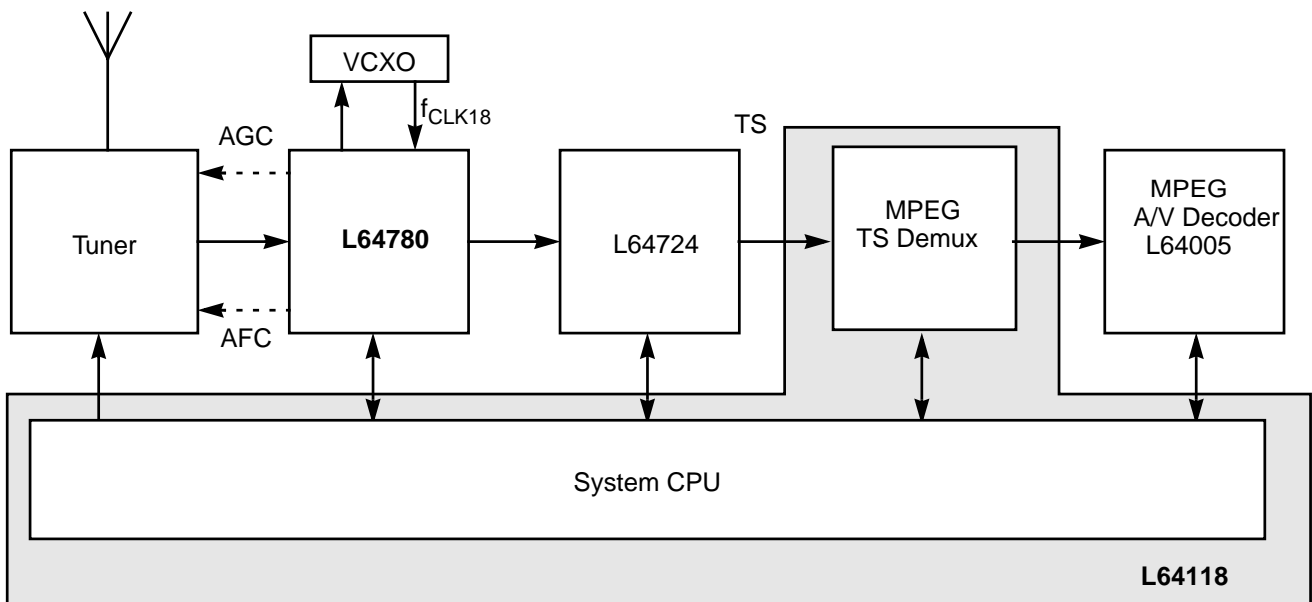

AGC (automatic gain control)

AFC (automatic frequency control)

[Figure 1.1](#) shows the basic structure for a terrestrial-only receiver. The UHF (or, possibly, VHF) signal from the antenna passes through a Tuner module that delivers a low intermediate frequency (IF) signal to the L64780 chip by means of an analog-to-digital converter (ADC). The L64780 chip performs all the essential functions for COFDM demodulation, excluding the final steps of error correction. It requires a sampling-frequency clock oscillator (at f_{CLK18} MHz), for which it provides the control voltage to lock its frequency to the desired value. The L64780 chip delivers soft-decision information to the L64705 or L64724 chip,

which then completes the error correction, delivering an MPEG-2 Transport Stream. Other MPEG-standard LSI Logic chips (for example, L64118 and L64005) can then be used to demultiplex the MPEG-2 Transport Stream into its coded audio, coded video, and data components, handle Conditional Access, and decode the audio and video signals for presentation to the display and loudspeakers. In [Figure 1.1](#), the microprocessor is embedded in the L64118. It controls RF-channel selection, mode selection for the L64780 chip, and program selection for the MPEG demultiplexer.

1.3 RF Tuner Block Functions

[Figure 1.2](#) indicates the functions performed within the RF Tuner block. The example uses a double-conversion approach, in which the RF Tuner converts the UHF signal to a first IF (IF1, where filtering, amplification, and gain control are done) followed by another conversion to the second low IF, (IF2), required at the input of the L64780.

Figure 1.2 UHF Tuner Example

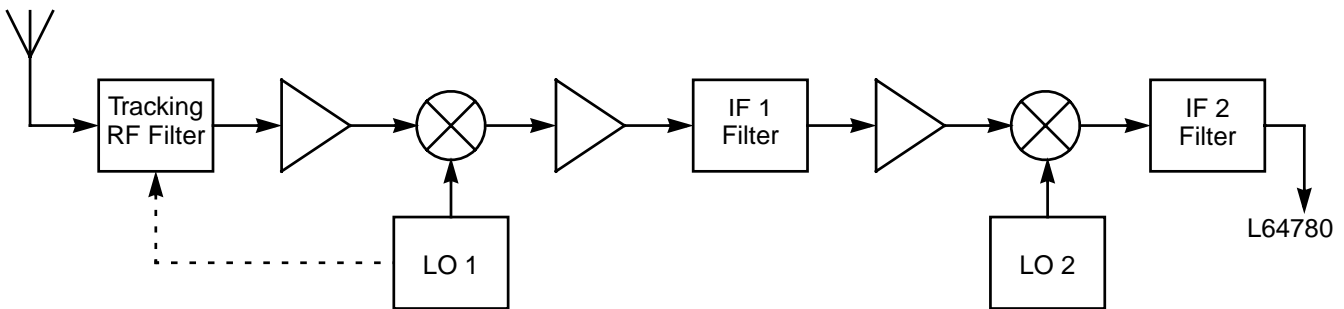

Figure 1.3 illustrates how terrestrial and satellite reception can be combined in one unit. For satellite reception, the IF signal (for example, from 1 to 2 GHz) from the dish unit is fed into a satellite tuner. This tuner:

1. Selects one RF signal from the 1 to 2 GHz range
2. Converts the signal to one or more intermediate frequencies
3. Down-converts the signal to base band
4. Feeds its I and Q components into the L64724 single-chip DVB-S satellite receiver

The L64724:

1. Samples the I and Q baseband signals
2. Demodulates the QPSK
3. Processes the error correction functions

The L64724 also implements a bypass of the ADC and demodulation functions. Thus, it can accept the soft decisions delivered by L64780 and feed them directly to the Viterbi decoder. This architecture implements a cost-effective solution for mixed satellite and terrestrial front-ends.

Figure 1.3 Receiver Architecture for Satellite and Terrestrial Reception

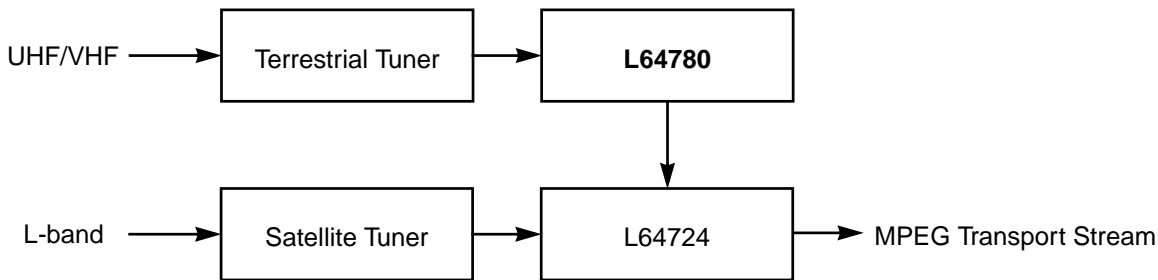

1.4 Modes of Operation

The L64780 supports all the modes of the DVB-T specification, including:

- 2 K and 8 K FFT sizes
- Nonhierarchical QPSK, 16 QAM, and 64 QAM constellations
- Hierarchical 16 QAM and 64 QAM constellations
- Constellation scale factors $\alpha = 1, 2, \text{ and } 4$
- Code rates of $1/2, 2/3, 3/4, 5/6, \text{ and } 7/8$
- Guard intervals of $1/4, 1/8, 1/16, \text{ and } 1/32$

1.5 Features

The L64780 features include:

- DVB-T compliance
- Internal or external DAC
- Digital real-to-complex conversion
- Spectrum inversion
- 2 K or 8 K FFT size
- Rapid time synchronization
- Rapid frequency synchronization
- Common phase error correction
- High-order filter for frequency interpolation
- Automatic mode switching
- Automatic frame detection
- Use of channel state information for protection against multipath and interference
- 3- or 4-bit soft decision outputs
- Analog or digital AFC
- AGC

- Stand-alone FFT mode (forward or inverse)
- Easy connection to the L64705 or L64724 for FEC
- 160-pin PQFP package

1.6 Typical Performance

Figure 1.4 illustrates the target performance of the L64780 compared to the simulation results in the ETSI specification for all the nonhierarchical modes in a Gaussian channel. Differences between the target performance and the simulations are accounted for as follows:

- About 1.5 dB for the noisy reference effect in the channel equalizer
- 0.1–0.3 dB for noise on the channel state measurement

It is not possible to be specific about the source of the remaining small difference (about 0.4 dB) because we do not have enough information about the conditions under which the simulations were performed.

The two losses (in the channel equalizer and channel state information) are compromises made in the interests of the speed of tracking of a time-varying channel. Sacrificing the tracking ability reduces the losses.

Figure 1.4 Performance with Additive White Gaussian Noise (AWGN)

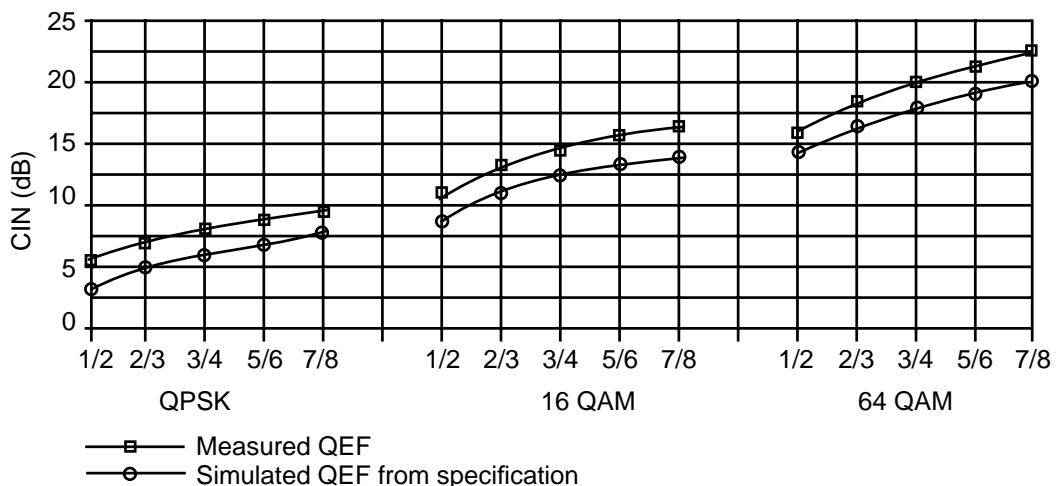

Figure 1.5 illustrates the target protection ratio of PAL-I into DVB-T. The point indicated by “carriers coincident about here” shows the point where the vision carrier of the PAL-I signal lines up directly with one of the carriers on the OFDM frequency raster.

Figure 1.5 DVB-T Carrier to Co-channel PAL-I Interference Ratio for Failure

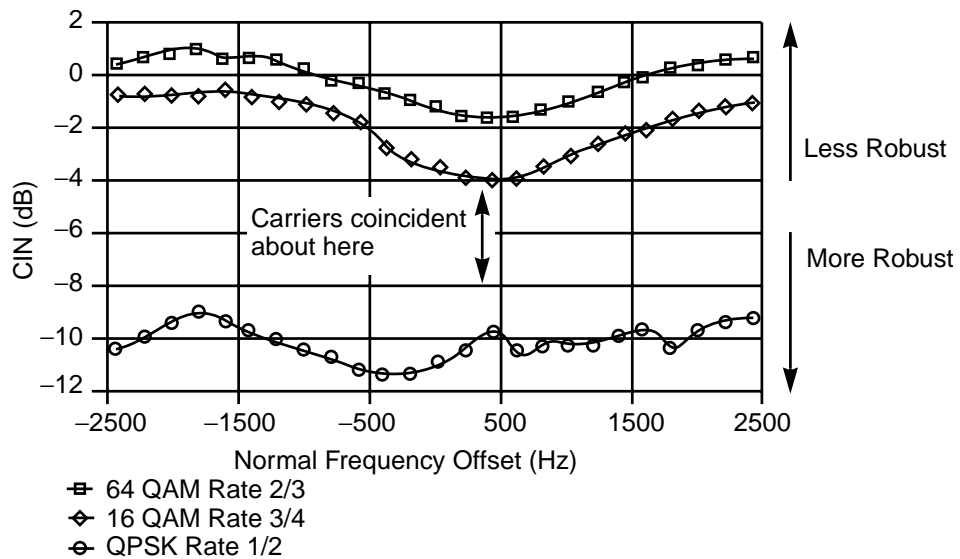
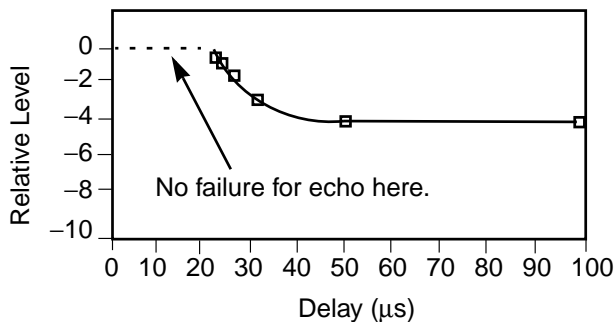

Figure 1.6 illustrates the maximum level of echo acceptable to the demodulator. The graph shows that in the selected mode, the demodulator works without failure inside the guard interval and without failure significantly outside it.

Figure 1.6 Maximum Level of a Single Echo for Failure of QPSK, Rate 1/2, Guard Interval 7



Chapter 2

Architectural Overview

This chapter describes the L64780 architecture and provides a functional description of each of its components. It contains the following sections:

- Section 2.1, “Demodulator Module Functional Description,” page 2-2
- Section 2.2, “Analog-to-Digital Converter (ADC),” page 2-4
- Section 2.3, “Automatic Gain Control (AGC),” page 2-4
- Section 2.4, “Real-to-Complex Conversion,” page 2-7
- Section 2.5, “Fast Fourier Transform (FFT) Block,” page 2-8
- Section 2.6, “Time Synchronization,” page 2-8
- Section 2.7, “Automatic Frequency Control (AFC),” page 2-10
- Section 2.8, “TPS Decoding and Frame Synchronization,” page 2-13
- Section 2.9, “Mode Control Logic,” page 2-14
- Section 2.10, “Channel Estimation and Equalization,” page 2-15
- Section 2.11, “Viterbi Metric Assignment and Quantization,” page 2-16
- Section 2.12, “Symbol Deinterleaver,” page 2-17
- Section 2.13, “Bit Deinterleaver,” page 2-17

2.1 Demodulator Module Functional Description

The components of the L64780 are integrated to provide a complete system solution for demodulation of terrestrial and satellite originated signals. [Figure 2.1](#) shows the components of the L64780 and indicates their interaction. These components are described in the following sections.

Figure 2.1 DTTV Demodulator Architecture

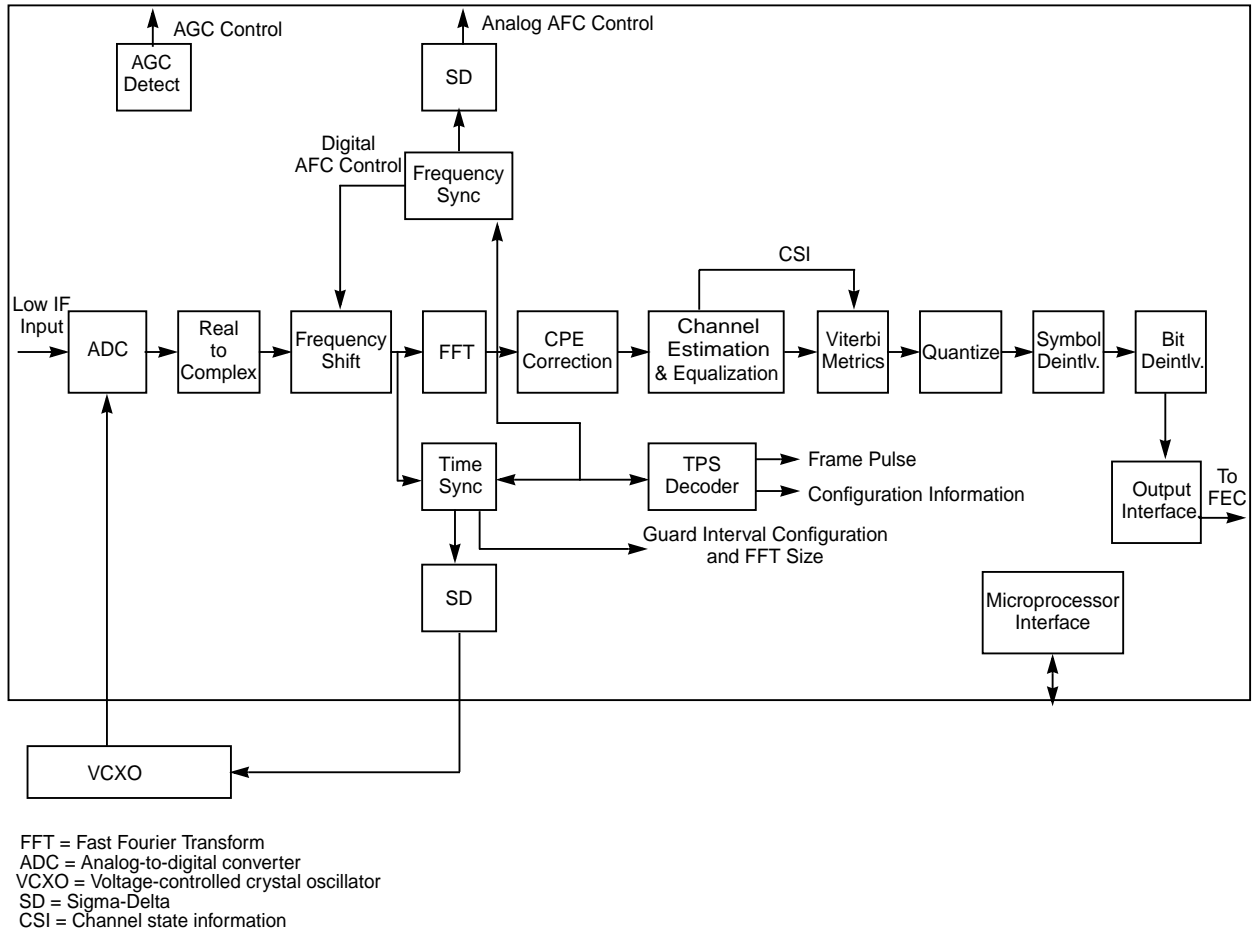

2.2 Analog-to-Digital Converter (ADC)

Features of the L64780 analog-to-digital converter include:

- low-IF center frequency input: 4.57 MHz
- input bandwidth: 8 MHz
- sampling clock: 18.29 MHz
- resolution: 8-bit

The L64780 also offers a 10-bit parallel port for connection to an external, 10-bit ADC.

2.3 Automatic Gain Control (AGC)

The Tuner AGC Amplifier amplifies the signal. The resulting signal has an RMS value of σ_0 . The AGC amplifies this signal so that its variance allows the FFT to work properly. To do this, the input signal power must be 10.95 dB down on the maximum ADC input range, normalized to 1.0. This means the RMS value of the input to the L64780 is: $\sigma_0 = 0.283$.

2.3.1 AGC Target RMS Value σ_T

Figure 2.2 defines The nine-bit AGC_TARGET register.

Figure 2.2 Structure of 9-Bit AGC_TARGET Register

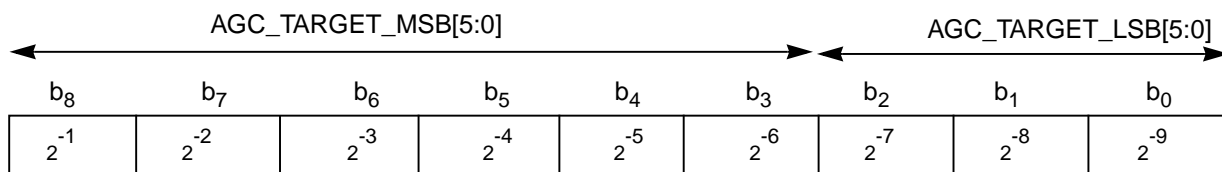

For the FFT to perform correctly, the input level of the COFDM signal must be 10.95 dB down on the normalized 1.0 Input Range. Thus, the target RMS value, σ , of the input signal must be 0.283, as shown in Equation 2.1.

$$\text{Equation 2.1} \quad \sigma_T = \left[512 \sqrt{\frac{2}{\pi}} \cdot \sigma \right]$$

Since the recommended RMS value is $\sigma = 0.283$, the recommended σ_T value is $\sigma = 0.226$, resulting in an AGC_TARGET initial value of 0x74 (0b0111.0100). Thus:

- AGC_TARGET_LSB = 0x4 (0b100)
- AGC_TARGET_MSB = 0x0E (0b01110)

Also see the description in [Section 4.4.4, “Address Line 0x0A,” page 4-23](#).

2.3.2 AGC External Loop Filter

The input power control signal drives the Sigma Delta modulated output, AGCOUT. Use the AGCOUT signal to drive an external passive RC filter that feeds the gain control stage, as shown in [Figure 2.3](#).

Figure 2.3 AGC Loop Pass Filter

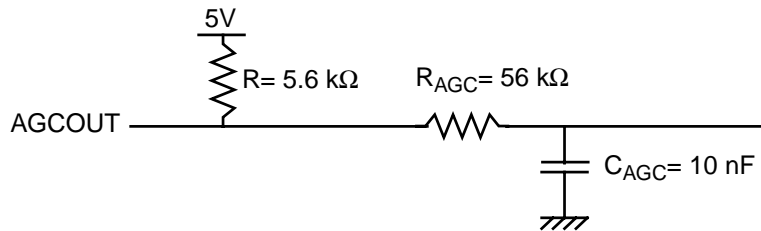

The R and C values for the low-pass filter must meet the following requirement:

Equation 2.2 $R_{AGC} \cdot C_{AGC} = 560 \mu\text{s}$

See [Figure 2.3](#) for the recommended values.

2.3.3 AGC Loop Gain K_s

The gain of the loop, K_s , must obey the following rule:

$$\text{Equation 2.3} \quad K_s = \frac{8.5 \times 10^{-5}}{F \cdot \sigma_T}$$

where:

- F is the slope of the tuner AGC characteristics in dB/V.
- σ_T is the target value for the input signal.

With an RMS value of $\sigma = 0.283$, and a tuner characteristic of 50 dB/V, the loop gain is:

$$\text{Equation 2.4} \quad K_s = 7.5 \times 10^{-6}$$

To code K_s , LSI Logic uses an approximation to the nearest power of 2. LSI Logic uses the AGC_GAIN[2:0] register, with the following correspondence:

$$\text{Equation 2.5} \quad K_s \approx 2^{-8-2 \cdot \text{AGC_GAIN}}$$

Because the number of values AGC_GAIN can have is limited, so are those of K_s . Thus,

$$\text{Equation 2.6} \quad \text{AGC_GAIN} \approx \left\lfloor \frac{\log K_s}{2 \log 2} - 4 \right\rfloor$$

In our example, AGC_GAIN = 4 is the most appropriate value, giving a value of:

$$\text{Equation 2.7} \quad K_s \approx 1.52 \times 10^{-5}$$

The real-to-complex block takes the input samples from the ADC output and converts them into a complex baseband representation for input to the FFT block.

2.4 Real-to-Complex Conversion

The DVB-T signal occupies a bandwidth of approximately 7.61 MHz; the signal is symmetrically disposed in extent about a notional center carrier. As radiated, this normally lies in the UHF range; however, its spectrum is not symmetrical, because its upper and lower sidebands are different (a double-sideband modulated signal does have a symmetrical spectrum). Thus, a complex representation is needed to describe it at baseband. This spectrum can be derived using the in-phase I and quadrature-phase Q demodulators, but each would have to be sampled separately, using two ADCs and many well-matched components.

The L64780 chip avoids the complexity and expensive matching of analog components. It uses a single ADC, and derives the complex-baseband representation by internal digital processing. The ADC samples the DVB-T signal at a low IF, then the real-to-complex block digitally shifts the samples to complex baseband form, centered on zero frequency. It is fundamental to the operation of this conversion processing that the nominal center frequency (f_{LIF}) of the low IF is related to the sampling frequency, f_{CLK18} , used by the ADC (see [Table 2.1](#), which shows that $f_{CLK18} = 4 f_{LIF}$ almost exactly). The AFC circuitry of the L64780 ensures that this is the case. The output of the block is complex numbers at the rate of $f_{CLK18}/2$.

The frequencies in [Table 2.1](#) apply for the normal version of the DVB-T specification for use with UHF channels spaced by 8 MHz. To adopt the DVB-T specification for use with 7 MHz or 6 MHz channel spacing, scale the clock frequency and all other frequencies within the system (including the bit-rate capacity and low IF) by factors of 7/8 and 6/8, respectively.

Table 2.1 Approximate and Exact Frequencies for Real to Complex Conversion

	Symbol	Approx. Frequency, MHz	Exact Frequency, MHz
ADC sampling frequency	f_{CLK18}	18.28	128/7
Low-IF center frequency	f_{LIF}	4.57	32/7

2.5 Fast Fourier Transform (FFT) Block

The FFT block converts from the temporal to the frequency domain representation. It has the following modes of operation:

- FFT and Inverse FFT
- 2 k (2048 points) and 8 k (8192 points) mode

2.6 Time Synchronization

This block finds the optimum timing for the start of the FFT window, and synchronizes the frequency of the clock, f_{CLK18} , to the received signal

The options for the duration of the symbol and the duration of the guard interval are given in paragraph 4.4 of the DVB-T/ETSI Specification.

The block takes the sequence of complex numbers from the real-to-complex conversion block and, to synchronize the clock, produces a control signal for the voltage-controlled oscillator. The control voltage of the VCXO is converted into a Sigma-Delta (Σ/Δ) Modulated signal and output as a single wire signal. This signal requires external low-pass filtering to extract its mean value, which represents the control voltage of the oscillator.

The transmitter repeats a segment of the signal during the guard interval. This block detects the repeated portion of the signal. The signal processing resists impairment from high levels of echoes or interference.

2.6.1 Timing Loop Gain

In 2 k mode, the optimal IIRGAIN is 0b01, or $\alpha \approx 3.125 \times 10^{-2}$.

This leads to K_I and K_P values of:

Equation 2.8 $K_I = \frac{1.69}{K_{VCXO}}$ $K_P = 512 \times K_I$

In 8 k mode, the optimal IIRGAIN is 0b11, or $\alpha \approx 7.8 \times 10^{-3}$.

This leads to K_I and K_P values equal to:

$$\text{Equation 2.9} \quad K_I = \frac{0.1}{K_{VCXO}} \quad K_P = 512 \times K_I$$

2.6.2 TIM_CLK_INIT Register Definition

The TIM_CLK_INIT register is defined as a two's complement 15-bit register that has the following meaning:

$$\text{Equation 2.10} \quad W_i = W_0 + \frac{5K_{VCXO} \times \text{TIM_CLK_INIT}}{2^{15}}$$

where W_0 is the central frequency of the VCXO.

2.6.3 TIM External Loop Filter

The control voltage signal of the VCXO drives the Sigma Delta modulated output, VCXOUT. Use the VCXOUT to drive an external passive RC filter that feeds the timing clock control stage. See [Figure 2.4](#).

Figure 2.4 External Low-Pass Loop Filter

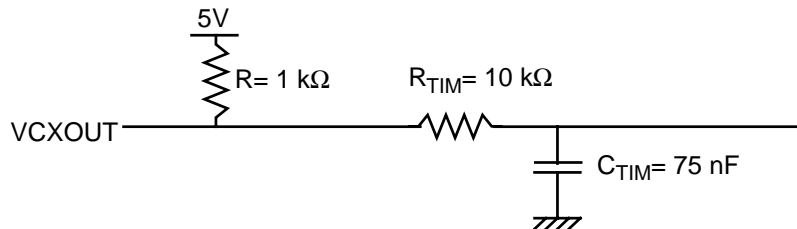

The -3 dB cutoff frequency of this system is $f_0 = 212 \text{ Hz}$, giving an estimate of the TIM Loop Bandwidth and resulting in a low-pass filter time constant $T1 = RC = 750 \mu\text{s}$.

The R and C values for the low-pass filter must meet the following requirement: $R_{\text{TIM}} \cdot C_{\text{TIM}} = 750 \mu\text{s}$.

2.7 Automatic Frequency Control (AFC)

The two methods for applying the correction required to achieve frequency synchronization are analog and digital. The method used depends on the design of the analog tuner. The L64780 allows both options, which are described in the following subsections.

2.7.1 Analog Frequency Synchronization

This block adjusts the frequency of the local oscillator in the tuner so that the center frequency of the low IF is equal to its nominal value of f_{LIF} . The adjustment must be accurate to within a small fraction of the carrier spacing, so that intercarrier interference is kept to an acceptably low level and the tracking ability of the channel estimation is not absorbed in correcting for the error in the frequency of the local oscillator.

The block takes the sequence of complex numbers from the output of the FFT block and produces a control signal for the local oscillator. This control signal is delivered as a single-wire Sigma-Delta (Σ/Δ) signal.

The initial error in the frequency of the local oscillator can be several times the carrier spacing; the measurement of the frequency error relies on the continual pilot carriers. The measurement range is ± 51.7 kHz in the 8k mode and ± 143 kHz in the 2k mode. The oscillator control signal is derived from the measured frequency error.

The value of the control signal can also be read and initialized through the microprocessor interface, which allows a previously stored value to be used when a channel is selected, making acquisition faster.

2.7.2 Digital Frequency Synchronization

This block uses digital signal processing (DSP) to correct for the tolerance in the frequency of the local oscillator in the tuner. The DSP shifts the frequency of the complex baseband signal so that its center frequency is zero. The shift needs to be accurate to within a small fraction of the carrier spacing so that intercarrier interference is kept to an acceptably low level and so the tracking ability of the channel estimation is not absorbed in correcting for the error in the frequency of the local oscillator.

The block takes the sequence of complex numbers from the output of the FFT block and produces a numerical control signal. It also takes the sequence of complex numbers from the real-to-complex conversion block and applies the frequency shift to the numbers according to the numerical control signal. Then, it passes the data on to the FFT block.

The digital frequency synchronization block comprises two parts: one to shift the frequency of the complex baseband signal, and one to measure the error in the center frequency of the complex baseband signal as presented to the FFT block.

Multiplying the signal by a rotating vector shifts the frequency of the complex baseband signal. A number-controlled oscillator (NCO) with sine and cosine outputs generates the rotating vector. The frequency range of the NCO is ± 143 kHz.

The error in the frequency of the local oscillator translates directly into an error in the center frequency of the complex baseband signal. The range of measurement is ± 51.7 kHz in the 8 k mode, and ± 143 kHz in the 2 k mode. The numerical control signal is derived from the measured frequency error.

Use the microprocessor interface to read and initialize the value of the control signal. This allows a previously stored value to be used when a channel is selected, thus making acquisition faster.

2.7.3 AFC Loop Gain

In digital AFC mode, the optimal sensitivity (K_{SENS}) is when the AFC_SENSITIVITY field in the Parameter Registers (see [page 4-18](#)) is set to 0b110:

$$\text{Equation 2.11} \quad K_{\text{SENS}} \approx 1.56 \times 10^{-2}$$

In analog AFC mode, the optimal AFC_SENSITIVITY is defined as:

$$\text{Equation 2.12} \quad K_{\text{SENS}} = \frac{74.4}{K_{\text{VCXO}}}$$

2.7.4 AFC_INIT_FREQ Register Definition

In AFC digital loop mode, the AFC_INIT_FREQ register is defined as a two's complement 24-bit register with the following usage:

$$\text{Equation 2.13} \quad W_i = W_0 + \left(\frac{143 \times 10^3}{2^{23}} \times \text{AFC_INIT_FREQ} \right)$$

where W_0 is the central frequency of the VCXO.

In AFC analog loop mode, the AFC_INIT_FREQ register is defined as a two's complement 24-bit register and in the L64780 has the following usage:

$$\text{Equation 2.14} \quad W_i = W_0 + \left(\frac{5K_{VCXO}}{2^{20}} \times \text{AFC_INIT_FREQ} \right)$$

where W_0 is the frequency of the VCXO.

2.7.5 AFC External Loop Filter

The control signal of the frequency loop drives the Sigma-Delta modulated output AFCOUT. Use the AFCOUT signal to drive an external passive RC filter that feeds the timing clock control stage, as shown in [Figure 2.5](#).

Figure 2.5 AFC Loop Pass Filter

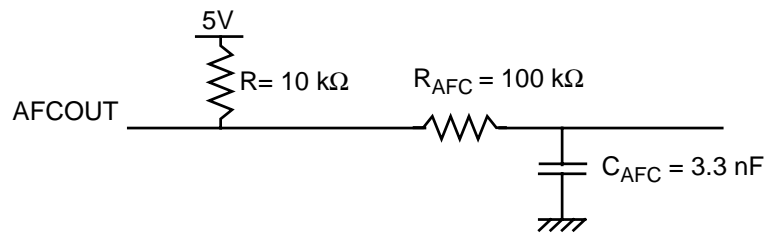

The -3 dB cutoff frequency of this circuit is $f_0 = 482$ Hz, giving a rough estimate of the Frequency Loop Bandwidth and resulting in a low-pass filter time constant:

$$\text{Equation 2.15} \quad T_1 = RC = 300 \mu\text{s}$$

The R and C values for the low-pass filter must meet the requirement shown in [Equation 2.16](#):

$$\text{Equation 2.16} \quad R_{\text{AFC}} \cdot C_{\text{AFC}} = 330 \mu\text{s}$$

2.8 TPS Decoding and Frame Synchronization

This block takes the sequence of complex numbers from the output of the FFT block and recovers the Transmission Parameter Signalling (TPS) data defined in paragraph 4.6 of the DVB-T/ETSI specification. The block passes the resulting data to the control logic of the L64780; it thus configures the mode of operation of much of the demodulator's circuitry.

The TPS data contains information on:

- The modulation system
- Whether the transmission is hierarchical
- What the value of α is (if the transmission is hierarchical)
- The inner code rate(s)
- The guard interval
- The mode: 2 k or 8 k

The guard interval and mode interaction cannot be used for acquisition, but assist the receiver in handling a reconfiguration of the transmission.

By implication, the TPS also indicates the phase of the four-symbol sequence of insertion of scattered pilots.

The TPS Decoder extracts the data bits from the TPS carriers and retains the most recent 67 bits. The decoder detects the start of the frame and carries out the Bose-Chaudhuri-Hocque (BCH) error check on the block of 67 bits, so that data containing errors can be discarded. All the data in the list above are passed to the control logic along with two flags: one indicates the start of a frame; the other indicates whether the error check detects errors. If there were no errors, the control logic uses the data to configure the demodulator, discarding any previous settings. The settings can be read and initialized through the microprocessor interface, which allows previously stored settings to be used when a channel is selected, making acquisition faster.

2.9 Mode Control Logic

If previously stored mode data are available, they are used when a channel is selected or when the signal strength rises after a period of signal loss. This is done by the means of an external microprocessor and makes acquisition faster. When the Mode Control Logic becomes an error-free TPS block, mode data from that TPS block replaces any previously determined mode data.

In this context, the mode data consists of:

- 2 k or 8 k mode
- Length of the guard interval
- Modulation system
- Hierarchy information
- Inner code rate

The mode control logic configures all the demodulator blocks whose operation is affected by these parameters. Acquisition of the demodulator is outlined in the following steps:

1. Achieve full synchronization of the FFT start and the clock frequency.
2. Make coarse and fine automatic frequency control (AFC) corrections, and achieve frequency synchronization.
3. Equalize the channel frequency response, once the Symbol Number is zero.
4. Wait up to one frame for the start of a TPS block, and wait another frame for the complete TPS block to be received. There is a wait of one or more additional frames, if necessary, until a TPS block is received without errors.
5. The modulation system, hierarchy information, and code rate from the TPS data are used to configure the Viterbi metric assignment block, and, by means of the microprocessor interface, the external Viterbi decoder(s).

2.10 Channel Estimation and Equalization

The output from the FFT block is a sequence of complex numbers, each describing the signal received on one of the COFDM carriers. The numbers correspond to the values, chosen from the points of the current constellation, which were used to modulate each carrier at the modulator. However, each carrier is received with unknown amplitude and phase due to the combined effects of:

- The channel through which the RF signal has passed (which, in general, is frequency selective)
- Any minor error in the FFT timing window

The purpose of the channel estimation and equalization block is to correct these effects so that the complex numbers at its output would, if plotted on an Argand diagram, correspond to points of the transmitted constellation (for example, QPSK, 16 QAM, or 64 QAM) except for any superimposed noise or interference.

The transmitted DVB-T signal contains “scattered pilots,” which are distributed among the data cells in a regular pattern (see [Figure 2.6](#)). These are transmitted with known values: the imaginary part is always zero, while the real part has a fixed amplitude. The sign of the real part, however, is determined by the carrier number (according to a pseudo-random function that also is used in a similar way to determine the real part of continual pilots).

Figure 2.6 Scattered Pilot Structure

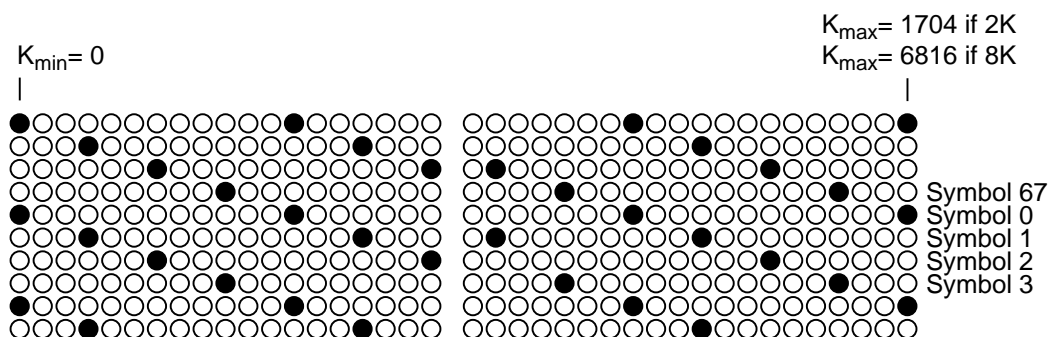

The Channel Estimation and Equalization Block compares each received scattered-pilot cell with the known transmitted value (derived from a

PRBS generator) to obtain a snapshot of the response of the “channel” (including any timing uncertainty) for the corresponding carrier at that time instant.

The data cells that must be corrected lie between the scattered pilots, in both frequency and time. This allows for appropriately generated corrections for each data cell by using a suitable form of interpolation applied to the measured values of the scattered pilots. As well as obtaining “in-between” values of the channel response, the interpolator also slightly reduces the effects of thermal noise on the scattered-pilot measurements. The reduction in noise and the fact that scattered pilots are transmitted with a power approximately 2.5 dB greater than data cells, keeps the inevitable loss of performance due to scattered-pilot noise within acceptable bounds.

2.11 Viterbi Metric Assignment and Quantization

This block takes in the sequence of complex numbers, each describing the signal received on one of the COFDM carriers, after equalization. These are the received versions of the complex numbers chosen at the modulator from the points of the current constellation, according to the coded bits to be sent. This block forms Viterbi metrics (“soft decisions”) for each of the received bits. These metrics are quantized and passed on, after reordering in the deinterleaver stages, to the associated Viterbi convolutional decoder. The use of “soft” rather than “hard” decisions is vital to obtaining the rugged properties of COFDM.

The associated Viterbi convolutional decoder, which resides on a separate chip (for example, the LSI Logic L64724), is capable of accepting soft decisions that are quantized to either three or four bits. Three bits are required for acceptable performance, while four bits improve the performance for higher-order modulation options of the DVB-T specification, especially with non-uniform constellations. Decoder chips designed primarily for QPSK or BPSK modulation commonly use three bits because the advantage of using four bits is minimal.

The L64780 chip provides 4-bit soft decisions, but it also can be used to drive 3-bit decoders.

2.12 Symbol Deinterleaver

From each received constellation point, the Viterbi metric assignment block extracts up to six soft decisions. The symbol deinterleaver accepts one COFDM symbol containing soft decisions and reorders them according to an algorithm defined in the DVB-T specification. It then passes this reordered data to the bit deinterleaver.

Echoes cause minima (“holes”) in the received spectrum, leading to groups of carriers on which the data is unreliable. For optimum operation of the Viterbi decoder, these groups of unreliable carriers must be split up. The symbol deinterleaver fulfills part of this function; the remainder is done by the bit deinterleaver.

In 2 k mode, there are 1705 COFDM carriers, of which 1512 in each symbol carry data. Each of these carriers yields either 2 (QPSK), 4 (16 QAM), or 6 (64 QAM) soft decisions. Each of these soft decisions consists of four bits of information. The effect of the operation of the symbol deinterleaver is to write the possible 1512 24-bit words into a RAM using one address sequence, and to read them using a different address sequence. This means there is a delay of one COFDM symbol between the input and the output. In the 8 k case, there are 6048 (out of a total of 6817) COFDM carriers that convey data; thus, the L64780 provides a 6048 by 24-bit RAM.

2.13 Bit Deinterleaver

In the presence of multipath or interference, some COFDM carriers convey data less ruggedly than others. Each COFDM carrier supplies either two, four, or six soft decisions; these would be impaired if the carrier they came from were impaired. For optimum operation of the Viterbi decoder, it is best if groups of unreliable soft decisions are maximally spaced. The purpose of the bit deinterleaver is to split up unreliable soft decisions caused by a single unreliable COFDM carrier. The symbol deinterleaver separates groups of unreliable COFDM carriers.

The bit deinterleaver accepts groups of 3-bit or 4-bit soft decisions generated from the same COFDM carrier from the symbol deinterleaver.

The bit deinterleaver rearranges these groups of soft decisions to separate soft decisions generated from the same carrier. The bit deinterleaver passes these soft decisions to the output interface of the L64780 for external decoding.

There are 6-bit deinterleavers, I0 to I5. For QPSK, one COFDM carrier provides two soft decisions: one from the real part, and one from the imaginary part. I0 deinterleaves the soft decision extracted from the real part; I1 deinterleaves the soft decision from the imaginary part. In this case, I2 to I5 are not used.

For 16 QAM (both hierarchical and nonhierarchical), one COFDM carrier provides four soft decisions: two from the real part, and two from the imaginary part. I0 deinterleaves the MSB soft decision extracted from the real part; I1 deinterleaves the MSB from the imaginary part. I2 deinterleaves the LSB from the real part; I3 deinterleaves the LSB from the imaginary part. In this case, I4 and I5 are not used.

For 64 QAM (both hierarchical and nonhierarchical), one COFDM carrier provides six soft decisions: three from the real part, three from the imaginary part. I0 deinterleaves the MSB soft decision extracted from the real part; I1 deinterleaves the MSB from the imaginary part. I2 deinterleaves the CSB from the real part; I3 deinterleaves the CSB from the imaginary part. I4 deinterleaves the LSB from the real part; I5 deinterleaves the LSB from the imaginary part.

Chapter 3

Interfaces

This chapter describes the interfaces for the LSI Logic L64780 DVB-T COFDM Demodulator. It consists of the following sections:

- Section 3.1, “Output Interface,” page 3-1
 - Section 3.2, “MUXIN Interface,” page 3-8
 - Section 3.3, “MUXOUT Interface,” page 3-13
 - Section 3.4, “Microprocessor Interface,” page 3-16
-

3.1 Output Interface

The output interface formats the soft decisions for presentation to the downstream Viterbi decoder. The input to this block is a stream of four-bit or 3-bit Viterbi soft decisions from the inner bit deinterleaver. The output from this block connects to a Viterbi decoder that is external to the L64780. The output from soft decisions is in a format suitable for direct connection to the L64724 or L64705.

This block operates differently in nonhierarchical and hierarchical modes, and can have a serial or parallel output format. This block’s operational modes are described in the following subsections.

3.1.1 Output Format in Nonhierarchical Mode

In nonhierarchical mode, the output format can be serial or parallel.

3.1.1.1 Serial Output Format

In serial output mode, the output port of the L64780 is configured as shown in [Figure 3.1](#).

Figure 3.1 Output Interface in Nonhierarchical and Serial Modes

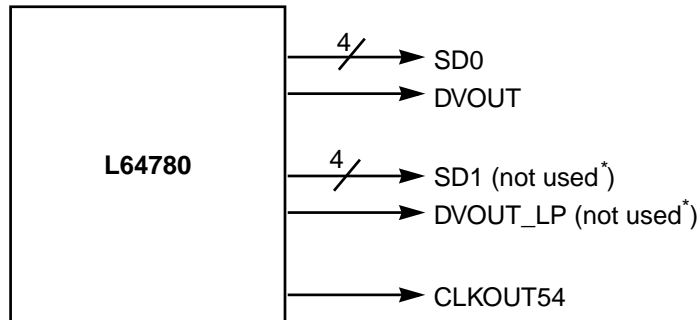

* When not used, the signal is deasserted LOW.

The output interface passes 4-bit or 3-bit soft decisions to the Viterbi decoder through the SD0 signal accompanied by the assertion of DVOUT. All outputs from the output interface are clocked at 54 MHz by CLKOUT54.

With a 64 QAM constellation, the L64780 extracts six soft decisions from every constellation point at 9 MHz; for example, one soft decision is presented every 54 MHz clock cycle. See [Figure 3.2](#).

Figure 3.2 Nonhierarchical, Serial Mode, 64 QAM Constellation

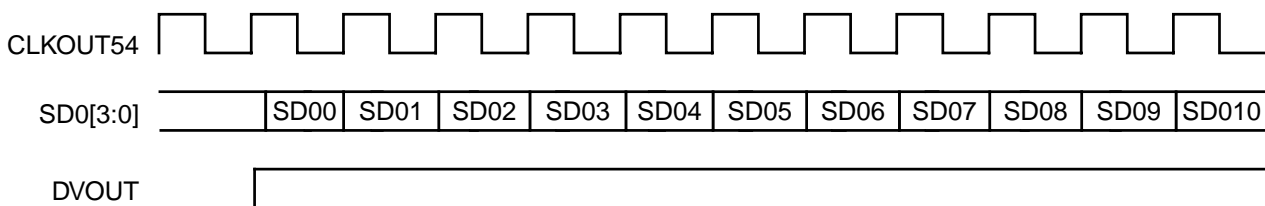

Every time a set of soft decisions is received from the bit deinterleaver, the DVOUT signal stays asserted for six 54 MHz clock cycles. The DVOUT signal is deasserted only during the scattered pilots, unused carriers, or guard interval.

For a 16 QAM constellation, during which four soft decisions are extracted every 9 MHz, the DVOUT signal stays asserted over four out of six 54 MHz clock cycles. See [Figure 3.3](#).

Figure 3.3 Nonhierarchical, Serial Mode, 16 QAM Constellation

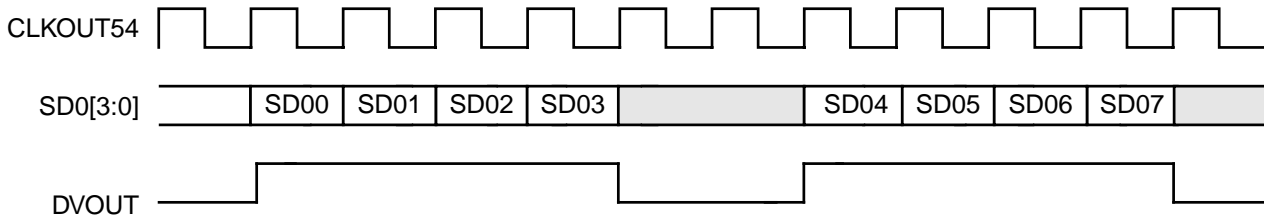

For the QPSK constellation, only two soft decisions are extracted every 9 MHz, resulting in DVOUT being asserted over two out of six 54 MHz clock cycles. See [Figure 3.4](#).

Figure 3.4 Nonhierarchical, Serial Mode, QPSK Constellation

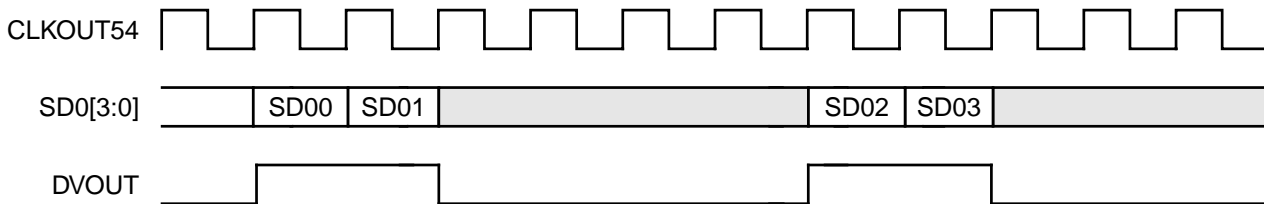

3.1.1.2 Parallel Output Format

In this mode, soft decisions are output in parallel, and the output interface of the L64780 is configured. See [Figure 3.5](#).

Figure 3.5 Output Interface in Nonhierarchical and Parallel Modes

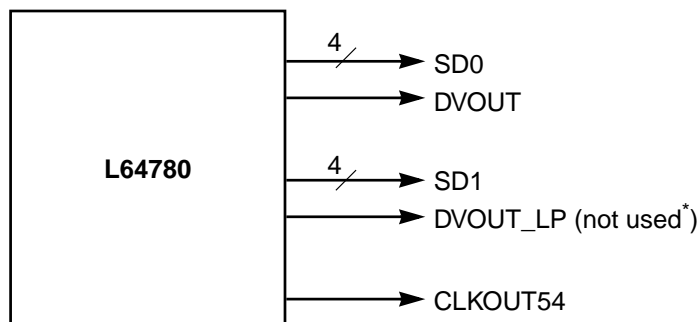

* When not used, the signal is deasserted LOW.

The output interface passes two soft decisions to the Viterbi decoder in parallel through SD0 and SD1, accompanied by a data valid indicator.

Because soft decisions are presented in parallel in 64 QAM, the soft decisions are presented in three consecutive 54 MHz clock cycles over a six 54 MHz clock cycle period (Figure 3.6). The DVOUT signal is deasserted during the scattered pilots, unused carriers, and guard interval.

Figure 3.6 Nonhierarchical, Parallel Mode, 64 QAM Constellation

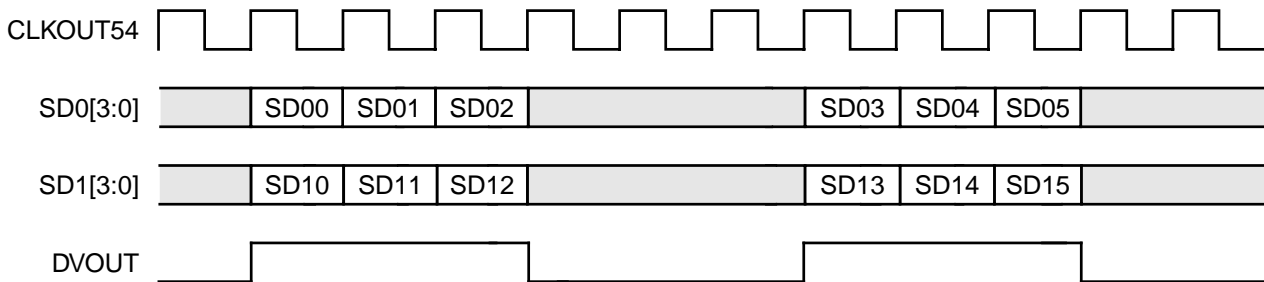

When a 16 QAM constellation is used, DVOUT is asserted for two 54 MHz clock cycles in six clock cycles (Figure 3.7). When QPSK is used, it is asserted for only one out of six clock cycles (Figure 3.8).

Figure 3.7 Nonhierarchical, Parallel Mode, 16 QAM Constellation

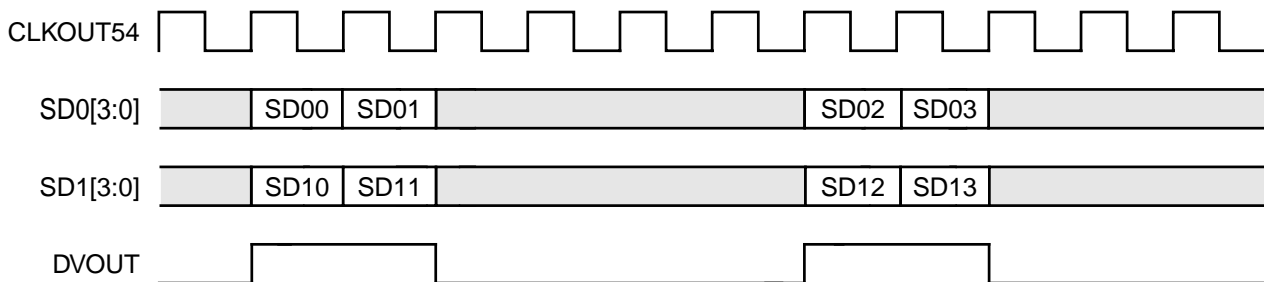
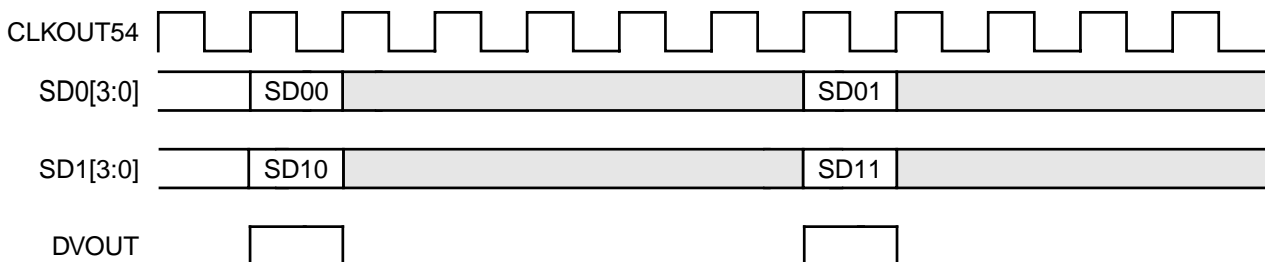

Figure 3.8 Nonhierarchical, Parallel Mode, QPSK Constellation



3.1.2 Output Format in Hierarchical Mode

The following subsections describe the decoding of High-Priority and Low-Priority data streams in hierarchical mode.

3.1.2.1 Decoding of HP and LP Streams

In hierarchical mode, the output port of the L64780 is configured (Figure 3.9). The High- and Low-Priority streams are delivered on SD0 and SD1, respectively. DVOUT validates the High-Priority data stream; DVOUT_LP validates the Low-Priority data stream.

Figure 3.9 Output Interface in Hierarchical and Two FECs Modes

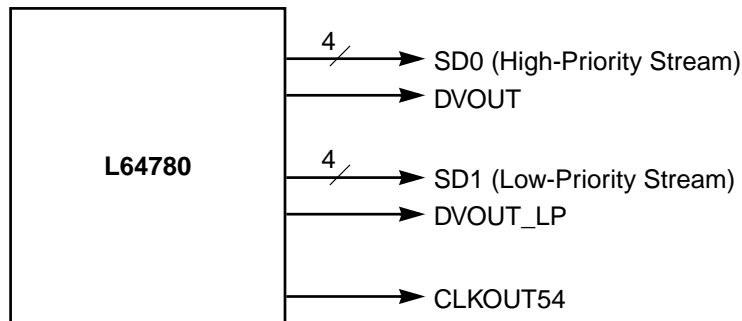

When in 16 QAM mode, two soft decisions are transmitted on SD0 and SD1. DVOUT and DVOUT_LP stay asserted for two of six 54 MHz clock cycles. See Figure 3.10.

Figure 3.10 Hierarchical, Two FEC Decoders, 16 QAM Constellation

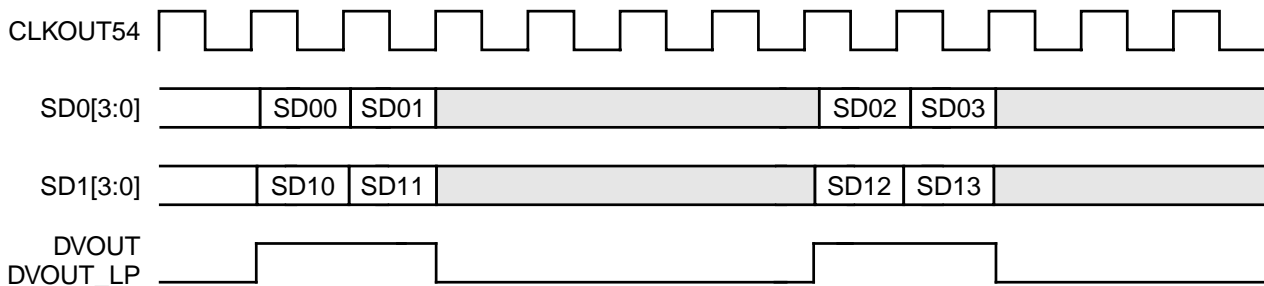

When in 64 QAM mode, two soft decisions are transmitted on SD0 and four soft decisions are transmitted on SD1. The DVOUT signal stays asserted during two 540 MHz clock cycles over six 54 MHz clock cycles and the DVOUT_LP signal stays asserted for four of six 54 MHz clock cycles. See [Figure 3.11](#).

Figure 3.11 Hierarchical, Two FEC Decoders, 64 QAM Constellation

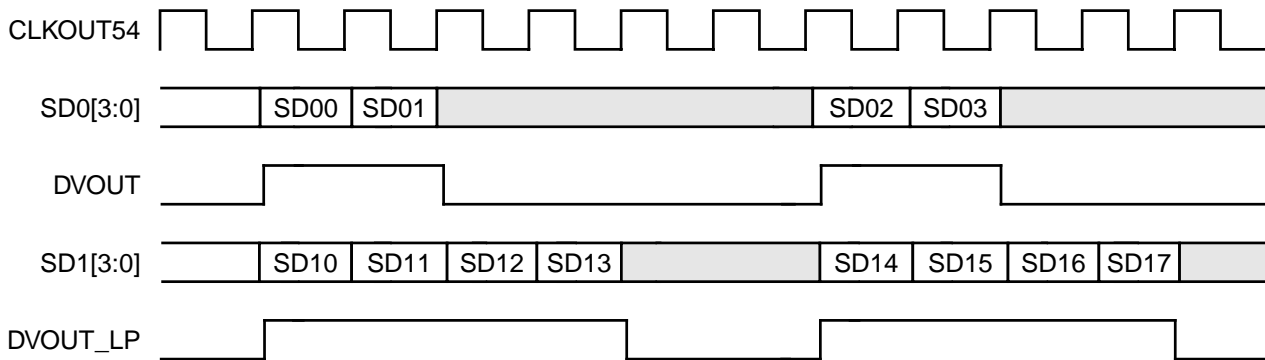

3.1.2.2 Decoding Only One Stream (HP or LP)

In this mode, the output port of the L64780 is configured ([Figure 3.12](#)). The DOF_HPLP signal selects between the HP and LP output streams. The data stream in this output format is the same as for the nonhierarchical case.

Figure 3.12 Output Interface in Hierarchical and One FEC Mode

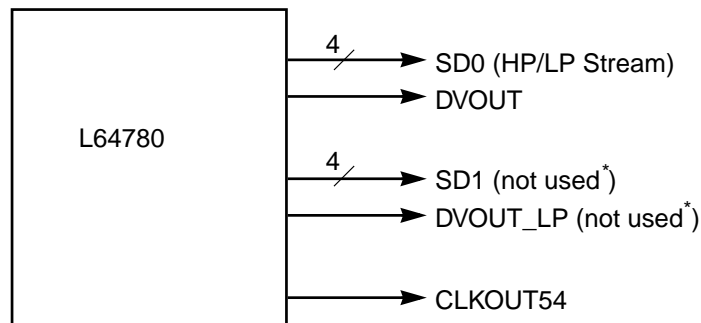

* When not used, the signal is deasserted LOW.

When a set of soft decisions is received from the Bit Deinterleaver block in 16 QAM (HP or LP selected) or in 64 QAM (only HP selected), two soft decisions are transmitted over SD0. The result is that DVOUT is asserted for two of six 54 MHz clock cycles. See [Figure 3.13](#).

Figure 3.13 Hierarchical, One FEC Decoder Mode With 16 QAM (HP or LP Selected) or 64 QAM (LP Selected only)

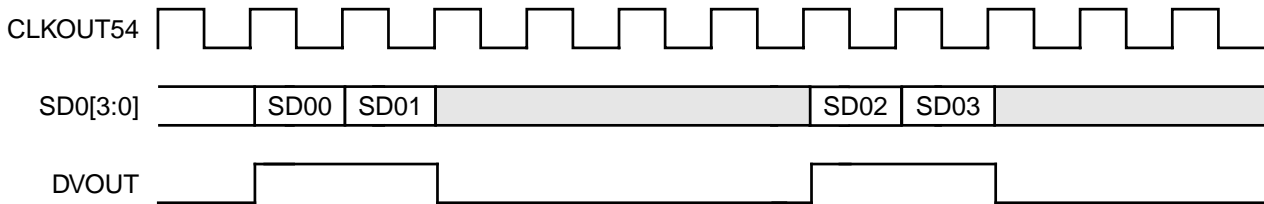

When a set of soft decisions is received from the Bit Deinterleaver block, and the DOF function is configured in 64 QAM with the LP data stream selected, four consecutive soft decisions must be transmitted over SD0. Thus, DVALIDOUT is asserted for four of six 54 MHz clock cycles. See [Figure 3.14](#).

Figure 3.14 Hierarchical, One FEC Decoder Mode With 64 QAM (HP Selected Only)

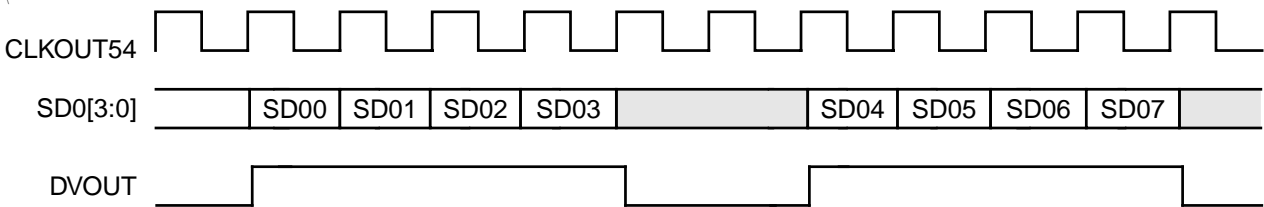

3.2 MUXIN Interface

The MUXIN bus lets you enter data (or test vectors) into the device at specific locations, which lets you bypass some front functional blocks and test an internal functional block.

Important: This interface is used for LSI Logic internal testing and is not intended for use in customer production receivers.

The MUXIN bus (MUXINBUS) is a 27-bit wide bus, multiplexed with the bypass ADC bus (DIGADCIN[9:0]). [Table 3.1](#) shows the bus mapping.

Table 3.1 MUXINBUS Mapping

MUXINBUS[26:10]	MUXINBUS[9:0]
MUXIN[16:0]	DIGADCIN[9:0]

Clocking data into the chip is very simple because the L64780 offers a clock output (CLKMUXIN) that automatically has the correct phase and frequency. CLKMUXIN automatically selects the correct internal clock, depending on the block selected. Figure 3.15 shows how to connect external logic that brings the data to the MUXINBUS.

Figure 3.15 MUXIN Signals Interface

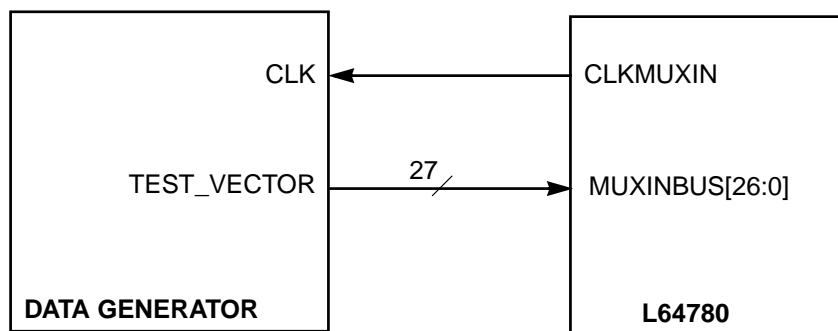

The MUXINBUS is software controlled and provides six testing possibilities. The control word is MUXIN_select[2:0], located at address 0x15, mapped on bits 3 to 5. [Table 3.2](#) defines the MUXIN_select[2:0] word.

Table 3.2 MUXIN Conifguration

MUXIN_select[2:0]	Definition
0	Normal mode
1	Access to Timing and DDFS block
2	Access to AFC block
3	Access to FFT block
4	Access to CSI block
5	Input to SDI block
6	Reserved
7	Reserved

3.2.1 Access to Timing and DDFS Blocks

When selecting access to the Timing and DDFS blocks, the CLKMUXIN signal is configured as an 18 MHz clock (more precisely, four times the low IF). The DDFS block is the digital rotator that performs the carrier frequency compensation.

The signals on the bus are I and Q data (in two's complement format), a start pulse (START), and a data valid signal (DV). These signals are mapped on the MUXINBUS. See [Figure 3.16](#).

Figure 3.16 Timing and DDFS Input Mapping

26	25	24	23	21	20	11	10	9	0
0	START	DV	0	Q[9:0]			0	I[9:0]	

In this mode, you can select whether the start pulse comes from the MUXINBUS or from the Timing recovery unit. The start pulse delimits every COFDM symbol. This selection is done through the DDFS_MODE bit (address 0x9, bit 1). If DDFS_MODE = 0, the start pulse comes from the test bus (test mode); otherwise, the Timing block delivers the start pulse. Note that this mode could correspond to an external down-converter that feeds the I and Q data directly into the Timing and DDFS blocks.

3.2.2 Access to the AFC Block

The AFC block performs the estimation of the carrier frequency drift and produces an analog or digital feedback control signal to compensate for this drift. In this mode, the CLKMUXIN signal is configured as a 36 MHz clock (more precisely, eight times the low IF).

The signals on the bus are I and Q data (in two's complement format), a start pulse (START), a data valid (DV) signal, and the COFDM symbol number (S_NB). These signals are mapped on the MUXINBUS. See [Figure 3.17](#).

Figure 3.17 AFC Input Mapping

26	25	24	23	22	21	20	11	10	9	0
0	START	DV	S_NB	0	Q[9:0]			0	I[9:0]	

In this mode, you can select whether the COFDM symbol number comes from the TPS informations (Frame Number) or from the MUXINBUS (S_NB). This selection is done through the AFC_MODE bit (address 0x5, bit 6). If AFC_MODE = 0, the COFDM symbol number comes from the MUXINBUS (S_NB) or full MUXIN mode; otherwise, it comes from the TPS register (partial MUXIN mode).

3.2.3 Access to the FFT Block

In this mode, the CLKMUXIN signal is configured as a 36 MHz clock (more precisely, eight times the low IF).

The signals on the bus are I and Q data (in two's complement format) and a start pulse (START). These signals are mapped on the MUXINBUS. See [Figure 3.18](#).

Figure 3.18 FFT Input Mapping

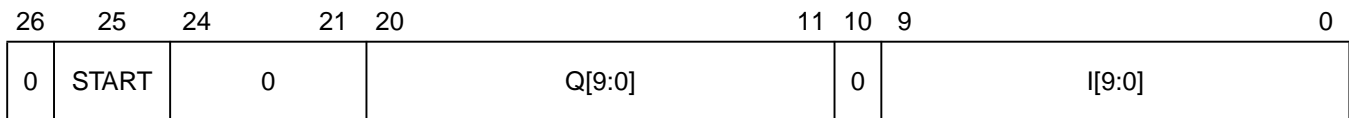

In this mode, the L64780 can be used as a stand-alone FFT processor in forward mode (FFT_DIR = 0) or in inverse mode (FFT_DIR = 1). The FFT_DIR register is located at address 0x11, bit 2.

3.2.4 Access to the CSI Block

The CSI block performs the Channel State Information (CSI) processing, which builds the soft decisions for the Viterbi decoder using *a priori* information from the Channel Equalizer (CE). In this mode, CLKMUXIN is configured as an 18 MHz clock (more precisely: four times the low IF).

The signals on the bus are I and Q data (in twos complement format), a start pulse (START), a data valid (DV) signal, the COFDM symbol number (S_NB), and a marker (or data valid) on scattered pilots (DVSP). These signals are mapped on the MUXINBUS. See [Figure 3.19](#).

Figure 3.19 CSI Input Mapping

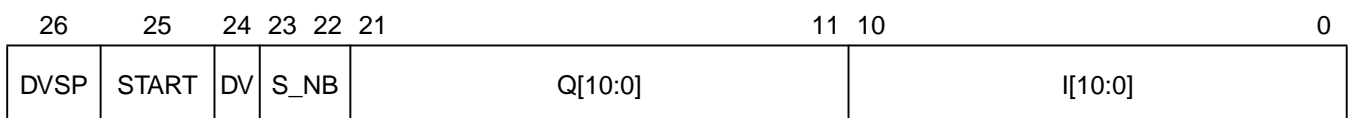

3.2.5 Access to the SDI Block

The SDI block performs Symbol Deinterleaving (SDI) as specified in the ETSI specification. In this mode, the CLKMUXIN signal is configured as an 18 MHz clock (more precisely, four times the low IF).

The signals on the 24-bit data bus (D) contain up to six soft decisions, up to four bits per soft decision, a start pulse (START), a data valid (DV) signal, and the symbol parity (S_P). An odd symbol number is marked by S_P = 1; even symbol numbers are marked by S_P = 0. These signals are mapped on the MUXINBUS. See [Figure 3.20](#).

Figure 3.20 SDI Input Mappings

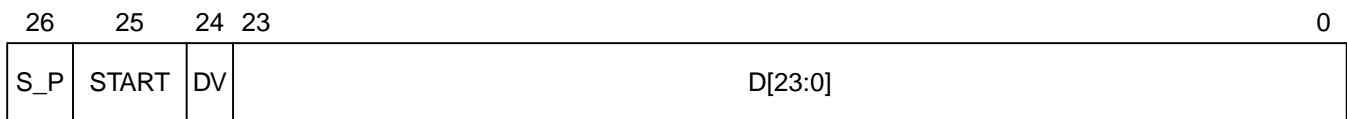

The data bus (D) is mapped in 3-bit and 4-bit soft decision modes, as shown in [Figure 3.21](#) and [Figure 3.22](#), respectively. The MSB is at the highest weight position. Note that X means reserved.

Figure 3.21 D[23:0] Bus Mapping in Three-Bit Soft Decision

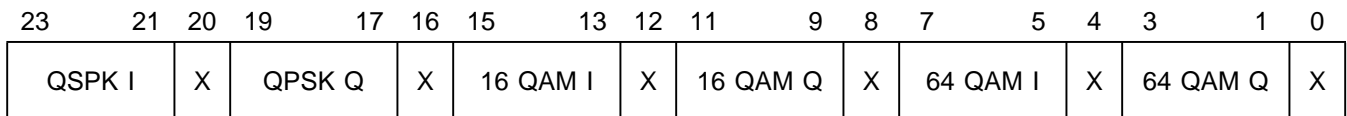
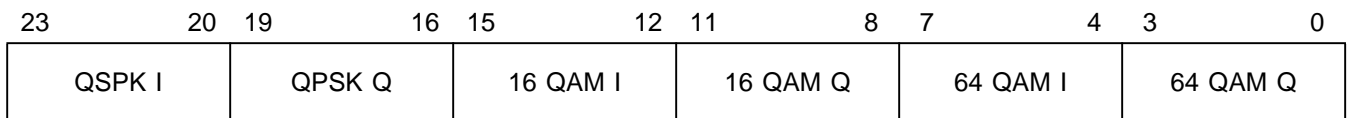

Figure 3.22 D[23:0] Bus Mapping in Four-Bit Soft Decision



3.3 MUXOUT Interface

The MUXOUT bus lets you probe any point in the device while receiving a transport stream (TS).

Important: This interface is used for LSI Logic internal test purposes and is not intended for customer production receivers.

MUXOUTBUS is 27 bits wide. For each probed point, data and control signals are available on this bus (including the clock). The clock has the same aspect ratio as CLKMUXIN; it is not a 50% duty cycle type.

Software controls the MUXOUTBUS, which provides five test possibilities. The control word is MUXOUT_select[2:0], located at address 0x15 (bits 2 to 0). [Table 3.3](#) define the MUXOUT_select word.

Table 3.3 MUXOUT_select Word Definition

MUXIN_select[2:0]	Definition
0	DDFS output
2	AFC output
3	CE output
4	CSI output
5	ADC output
6	Reserved
7	Reserved

Note that the MUXOUT bus can be 3-stated by asserting the MUX_CTRL bit (bit 3 of the Mode Register Address Line), at address 0x19. The bus is active when MUX_CTRL is set to 0.

3.3.1 DDFS Output

The DDFS output lets you probe signals after carrier frequency compensation and prior to FFT processing. The signals are I and Q data (in two's complement format), a start pulse that delimits the COFDM symbols (START), a data valid (DV) signal that accompanies valid data, and an 18 MHz clock. These signals are mapped on the MUXOUTBUS. See [Figure 3.23](#).

Figure 3.23 DDFS Output Mapping

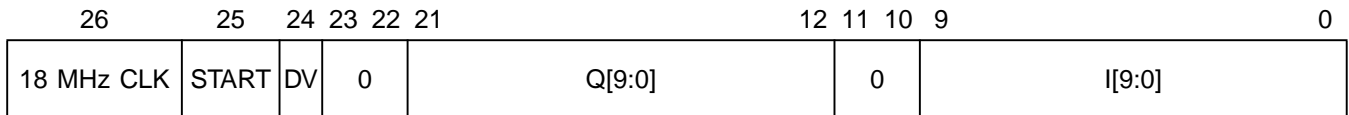

3.3.2 FFT Output

The FFT output lets you probe data prior to Common Phase Error (CPE) correction and Channel Equalization (CE). The signals are I and Q data (in two's complement format), a start pulse that delimits the COFDM symbols (START), a data valid (DV) signal that accompanies valid data, and a 36 MHz clock. These signals are mapped on the MUXOUTBUS. See [Figure 3.24](#).

Figure 3.24 FFT Output Mapping

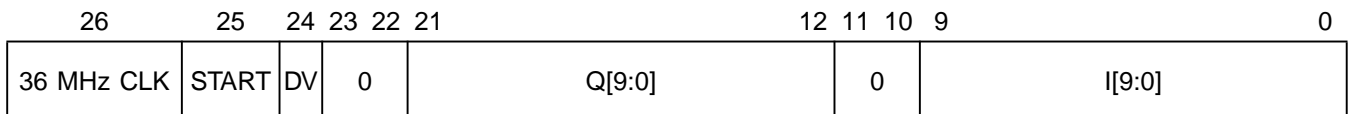

3.3.3 AFC Output

The AFC output lets you probe data after Common Phase Error (CPE) correction and prior to Channel Equalization (CE). The signals are I and Q data (in two's complement format), a start pulse that delimits the COFDM symbols (START), a data valid (DV) signal that accompanies valid data, and a 36 MHz clock. These signals are mapped on the MUXOUTBUS. See [Figure 3.25](#).

Figure 3.25 AFC Output Mappings

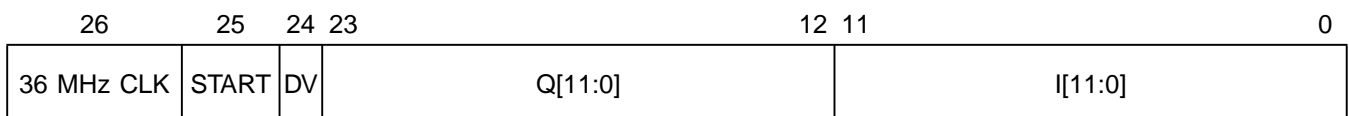

3.3.4 Channel Equalizer (CE) Output

The Channel Equalizer (CE) output lets you probe data after channel equalization or the frequency response of the channel. After channel equalization, you can display the constellation by feeding I and Q data into two DACs. For constellation display purposes, the DACs require only 8-bit resolution.

The signals at this point are I and Q data in two's complement format, a start pulse that delimits the COFDM symbols (START), a data valid (DV) signal that accompanies valid data, and a 36 MHz clock. These signals are mapped on the MUXOUTBUS. See [Figure 3.26](#).

Figure 3.26 CE Output Mappings

26	25	24	23	12	11	0
36 MHz CLK	START	DV	Q[11:0]			I[11:0]

The I and Q data available on the bus represent either the equalized data or frequency response of the channel depending upon the CE_SELECT bit (address 0x11, bit 3). When CE_SELECT = 0, equalized data are present on the MUXOUT bus; otherwise, the MUXOUT bus contains the channel response in the frequency domain.

3.3.5 CSI Output

The CSI output provides an averaged measure per carrier on the confidence to be placed on the hard decision.

The signals present at this point are the degree of confidence (CSI), a start pulse that delimits the COFDM symbols (START), a data valid (DV) signal that accompanies valid data, and an 18 MHz clock. These signals are mapped on the MUXOUTBUS. See [Figure 3.27](#).

Figure 3.27 CSI Output Mappings

26	25	24	23	11	10	0
18 MHz CLK	START	DV	0	CSI[10:0]		

A high value on the CSI bus indicates a low level of confidence, and vice-versa. The CSI word is nonsigned data, which can be used to drive a bar graph representing the quality of reception in a channel.

3.3.6 ADC Output

The ADC output lets you probe the internal ADC. The signals are the digitized input samples (ADC) and the 18 MHz clock. These signals, which are in two's complement format, are mapped on the MUXOUTBUS. See [Figure 3.28](#).

Figure 3.28 ADC Output Mapping

26	25	8	7	0
18 MHz CLK	0		ADC[7:0]	

3.4 Microprocessor Interface

The microprocessor interface operates in Serial Mode.

Important: A Parallel mode interface is provided for test purposes. This interface is used for LSI Logic internal testing and is not intended for use in customer production receivers.

The Serial Bus mode interface is a serial interface operating in slave mode. Its protocol is compatible with I²C specifications. For a more detailed description of the Serial Bus, see [Appendix A](#). The P_S input signal selects either the serial or parallel mode. [Table 3.4](#) summarizes the different modes.

Table 3.4 Mode Selection Using the P_S Input Signal

P_S	Mode	Notes
Low	Parallel	LSI Internal use only
High	Serial	L64780 Serial Interface

When in Serial interface mode, D0 is used as a serial data signal, and A0 is used as a serial clock signal. D[7:1] are used to set the serial bus slave address. When using the serial bus, D[7:1] must be hardwired to set the appropriate device slave address.

Chapter 4

Register Descriptions

This chapter provides an overview of the L64780 register space and gives a detailed description of its registers. This chapter consists of the following sections:

- Section 4.1, “Memory Map,” page 4-2
- Section 4.2, “Interrupt Registers,” page 4-7
- Section 4.3, “TPS Registers,” page 4-11
- Section 4.4, “Parameter Registers,” page 4-16
- Section 4.5, “Mux Register Address Line 0x15,” page 4-32
- Section 4.6, “Performance Monitoring Registers Address Line 0x16,” page 4-34
- Section 4.7, “Mode Register Address Line 0x19,” page 4-36
- Section 4.8, “3-Wires Register Address Line 0x1A,” page 4-38

4.1 Memory Map

Table 4.1 lists all L64780 registers and provides the DTTV demodulator internal memory map. A description of each of these registers groups is provided in the following sections.

Table 4.1 L64780 Registers and Internal Memory Map

Space	Address	Register name	Register Width (Bits)	Type
1	0x00	Interrupt register	2	R
	0x01	Interrupt Mask register	2	R/W
	0x02	TPS register 1	4	R/W
	0x03	TPS register 2	6	R/W
	0x04	TPS register 3	7	R/W
	0x05	Parameters register 1	8	R/W
	0x06	Parameters register 2	8	R/W
	0x07	Parameters register 3	8	R/W
	0x08	Parameters register 4	8	R/W

Table 4.1 L64780 Registers and Internal Memory Map (Cont.)

Space	Address	Register name	Register Width (Bits)	Type
2	0x09	Parameters register 5	8	R/W
	0x0A	Parameters register 6	8	R/W
	0x0B	Parameters register 7	8	R/W
	0x0C	Parameters register 8	8	R/W
	0x0D	Parameters register 9	8	R/W
	0x0E	Parameters register 10	8	R/W
	0x0F	Parameters register 11	8	R/W
	0x10	Parameters register 12	8	R/W
	0x11	Parameters register 13	8	R/W
	0x12	Parameters register 14	3	R/W
	0x13	Parameters register 15	6	R/W
	0x14	Parameters register 16	6	R/W
3	0x15	MUX register	6	R/W
	0x16	Performance Monitoring register 1	6	R/W
	0x17	Performance Monitoring register 2	8	R
	0x18	Performance Monitoring register 3	8	R
	0x19	Mode register	6	R/W
	0x1A	3 Wires register	6	RW

Figure 4.1 through Figure 4.3 give a graphical view of the register address space. Shaded parts in these figures denote reserved bits.

Figure 4.1 Graphical View of the L64780 Register Address Space 1

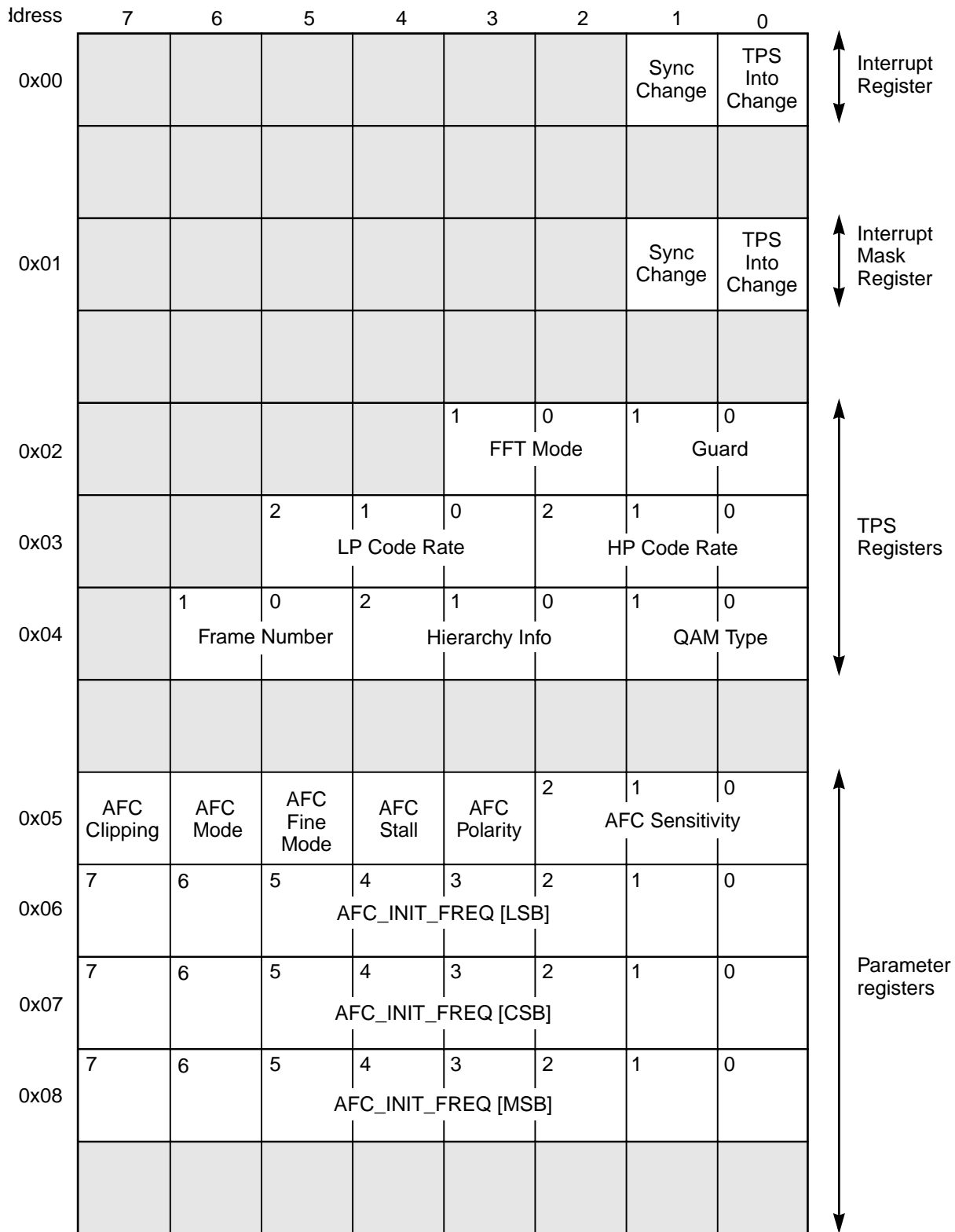

Figure 4.2 Graphical View of the L64780 Register Address Space 2

Address	7	6	5	4	3	2	1	0	
0x09	Soft Decision Width	BDI Disable	SDI Disable	DOF Out Format		DDFS Disable	DDFS Mode	ADC On Chip	
0x0A	AGC Target[LSB]			AGC Disable	AGC Polarity	2	1	0	
0x0B	ADC Format	R2C SI	5	4	3	2	1	0	
	AGC target[MSB]								
0x0C	2	1	0	2	1	2	1	0	
	TIM_LOOP_I		TIM_LOOP_P			TIM IIRgain			
0x0D	7	6	5	4	3	2	1	0	
	Timing Offset Position[LSB]								
0x0E	TIM STALL	TIM Polarity	Timing Offset Position[MSB]						
0x0F	7	6	5	4	3	2	1	0	
	Timing CLK INIT [LSB]								
0x10	7	6	5	4	3	2	1	0	
	Timing CLK INIT [MSB]								
0x11	CPE Disable	CE Disable	Disable ETS	TEMPO Type	CE Select	FFT Direction	FFT Gain setting		
0x12						CSI Out Format	CSI IIRate		
0x13			5	4	3	2	1	0	
	HP_OFFSET								
0x14			5	4	3	2	1	0	
	LP_OFFSET								

Parameter Registers

Figure 4.3 Graphical View of the L64780 Register Address Space 3

Address	7	6	5	4	3	2	1	0	
0x15			2	1	0	2	1	0	MUX Register
			MUXIN Select			MUXOUT Select			
0x16			Frame Sync OK	TPS OK	Freq Sync OK	TIM Clock Sync OK	TIM Start Sync OK	Sync OK	Performance Monitoring Registers
0x17	7	6	5	4	3	2	1	0	
	Average Channel State Information Indication								
0x18	7	6	5	4	3	2	1	0	
	Peak Channel State Information Indication								
0x19		Odrain Ctrl	Wires3 Ctrl	SD Ctrl	MUX Ctrl	Soft Reset	Auto Mode Enable	Change Mode	Mode Register
0x1A			2	1	0	2	1	0	3 Wires Register
			WIRES3_IN			WIRES3_OUT			

The Sync change event is visible through the signal SYNC CHANGE (see [Section 4.6, “Performance Monitoring Registers Address Line 0x16”](#)) and occurs when at least one of the following synchronizations has changed during the demodulation:

- The Frame_Sync_OK bit is set to 1 when the frame synchronization is reached and reset to 0 when the frame synchronization is lost. The Frame_Sync_OK bit is visible through the Performance Monitoring register.
- The Freq_Sync_OK bit is set to 1 when the demodulator is frequency locked and reset to 0 when the frequency synchronization is not yet reached or lost. The Freq_Sync_OK bit is visible through Performance Monitoring Register 1.
- The Start_Sync_OK bit is set to 1 when the timing block has properly determined the start of the FFT; it is reset to 0 when this is lost. Start_Sync_OK bit is visible through Performance Monitoring Register 1.
- The Clock_Sync_OK bit is set to 1 when the sampling frequency is properly locked; it is reset to 0 when sync is not reached. Clock_Sync_OK is visible through Performance Monitoring register 1.
- The TPS_Sync_OK bit is set to 1 when the TPS frame is error free; it is reset to 0 when the frame is corrupted. The TPS_Sync_OK bit is visible through Performance Monitoring Register 1.

TPS_INFO_CHANGE

TPS Change Interrupt

R 0

A valid TPS structure has been received that differs from the current mode of the DTTV demodulator. This interrupt does not occur if the only change is in the frame number.

The TPS_INFO_CHANGE bit is initially reset to 0 (no interrupt). If this bit is set to 1, an interrupt is generated.

The TPS_INFO_CHANGE bit is set to 1 only when the received error-free (BCH-correct) TPS is different from the last TPS information stored in the TPS registers. This bit is only reset by a microprocessor read access. The TPS_INFO_CHANGE bit is evaluated every COFDM frame, and it is visible through the TPS_INFO_CHANGE signal (see [Section 4.3, “TPS Registers”](#)).

4.2.2 Interrupt Mask Register, Address Line 0x01

The microprocessor can select between a polling or interrupt driven approach by programming the Interrupt Mask register. Only when the bit in the Interrupt Mask register associated with the event bit in the Interrupt register is set to 1 is the interrupt for this event is enabled; otherwise, polling is selected.

Any interrupt-related events reported in the Interrupt register lead to the assertion of the INT_n signal (active LOW). On receiving an interrupt signal, the microcontroller is expected to read the Interrupt register to identify the cause(s) of this interrupt. The microcontroller thereby resets all interrupt events in the Interrupt register; this remains in effect until a new interrupt (TPS info change or Sync change) occurs. To disable permanently the interrupt mechanism, reset the Interrupt Mask register. [Figure 4.4](#) shows an implementation of the interrupt generation.

Figure 4.4 Interrupt Generation

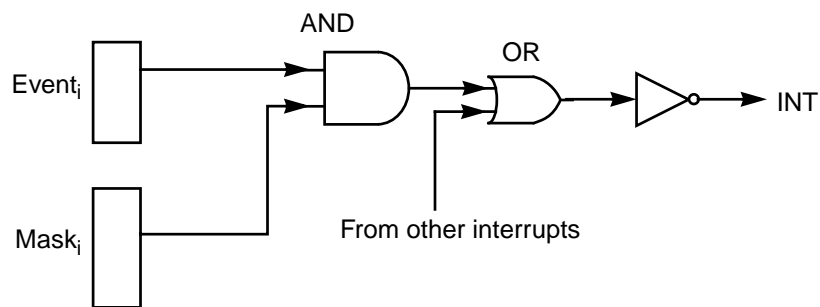

Note that a read access to Address 0 resets the Interrupt Register. But it does not mask new interrupts that arise at the time the host reads the interrupt register; thus, when the Host reads the interrupt register, each interrupt is either reset, or set again if a new interrupt occurs.

7	2	1	0
0x01	RES	SYNC_CHANGE_MASK	TPS_INFO_CHANGE_MASK

RES **Reserved** **[7:2]**
 These bits are reserved.

SYNC_CHANGE_MASK
Synchronization Change Interrupt Mask **R/W 1**
 This bit enables or disables the generation of an interrupt if one or more aspects of the DTTV demodulator synchronization have changed. If this bit is 0, the interrupt is masked; if the bit is 1, the interrupt is enabled. The initial condition for this bit is 0.

TPS_INFO_CHANGE_MASK
TPS Change Interrupt Mask **R/W 0**
 This bit enables or disables the generation of the interrupt for the TPS_INFO_CHANGE bit. If this bit is 0, the interrupt is masked; if the bit is 1, the interrupt is enabled. The initial condition for this bit is 0.

4.3 TPS Registers

These registers have two functions, depending on whether they are read from, or written to. If they are read from, they indicate that the contents of the last TPS structure were correctly received. If they are written to, they set the next mode of operation of the DTTV demodulator. The mode change does not take effect until the CHANGE_MODE command is issued (by setting the CHANGE_MODE bit in the Mode register). The meaning of the bits contained in the TPS are described in the ETSI specification.

4.3.1 Address Line 0x02

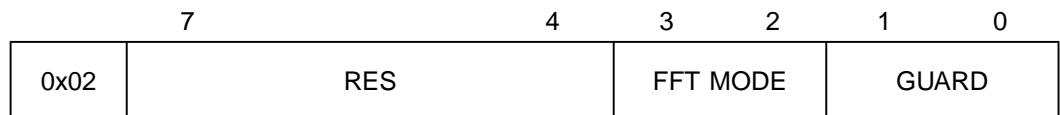

RES **Reserved** **[7:4]**
These bits are reserved.

FFTMODE **COFDM Transmission Mode** **R/W [3:2]**
When this register is read, these bits provide the last value received by the channel, using the TPS signalling information.
When the register is written, these bits store the next COFDM transmission mode value that the system uses. The values are:

FFTMODE[1:0]	Definition
00	2 k Mode
01	8 k Mode
10	Unused
11	Unused

The initial condition for the FFTMODE is 0b00 (2k).

GUARD **Guard Interval** **R/W [1:0]**

When this register is read, the Guard Interval provides the last value received by the channel, using the TPS signalling information.

When this register is written, Guard [1:0] stores the next Guard value that the system uses. The values are:

GUARD[1:0]	Definition
00	1/32 Guard Interval
01	1/16 Guard Interval
10	1/8 Guard Interval
11	1/4 Guard Interval

The initial condition for the Guard Interval is 0b00 (1/32).

4.3.2 Address Line 0x03

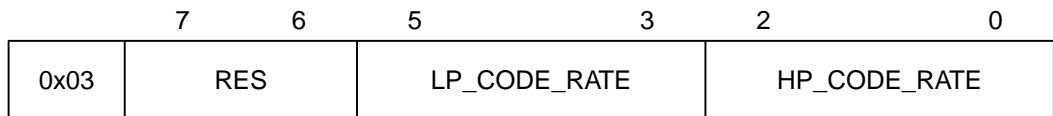

RES **Reserved** **[7:6]**
These bits are reserved.

LP_CODE_RATE **Viterbi Low-Priority Code Rate** **R/W [5:3]**
When this register is read, these bits provide the last value received by the channel, using the TPS signalling information.

When this register is written, these bits store the next Viterbi Code Rate for the Low-Priority stream value that the system uses. The values are:

LP_CODE_RATE[2:0]			Definition
0	0	0	1/2 Code Rate
0	0	1	2/3 Code Rate
0	1	0	3/4 Code Rate
0	1	1	5/6 Code Rate
1	0	0	7/8 Code Rate
1	0	1	Reserved
1	1	0	Reserved
1	1	1	Reserved

The initial condition for the LP_CODE_RATE is 0b000 (1/2).

HP_CODE_RATE

Viterbi High-Priority Code Rate

R/W [2:0]

When this register is read, these bits provide the last value received by the channel, using the TPS signalling information.

When this register is written, these bits store the next Viterbi Code Rate for the High-Priority stream value that the system uses. The values are:

HP_CODE_RATE[2:0]		Definition
000		1/2 Code Rate
001		2/3 Code Rate
010		3/4 Code Rate
011		5/6 Code Rate
100		7/8 Code Rate
101		Reserved
110		Reserved
111		Reserved

The initial condition for these bits is 0b001 (2/3).

4.3.3 Address Line 0x04

7	6	5	4	2	1	0
0x04	RES	FRAME_NB	HIERARCHY		QAMTYPE	

RES **Reserved** **7**
This bit is reserved.

FRAME_NB **COFDM Frame Number** **R [6:5]**
When this register is read, these bits provide the last value received by the channel, using the TPS signalling information. The values are:

FRAME_NB[1:0]		Definition
0	0	Frame 0
0	1	Frame 1
1	0	Frame 2
1	1	Frame 3

The initial condition for the FRAME_NB is 0b00 (Frame 0). Internally, there are three TPS registers:

- The first (0x02, the active TPS register) contains the current mode of the DTTV demodulator.
- The second (the next TPS register, 0x03) is written by writing to the TPS register in the register map. When the “change mode” command is issued, the next TPS register is copied into the active TPS register, and this becomes the current mode of the demodulator.
- The third register (the received TPS register, 0x04) contains a copy of the last valid TPS that was received in the input signal. This register can be read by reading from the TPS register in the register map.

If the AUTO_MODE_ENABLE bit is set, then every time a valid TPS is received and a super-frame boundary is detected, the demodulator copies the contents of the received TPS register into the active TPS register (and changes the current mode of the DTTV receiver if the received TPS changes).

If the received TPS (stored in the received TPS register) and the current mode of the DTTV demodulator (held in

the active TPS register) differ, the TPS_INFO_CHANGE bit is set to 1 for one CLK18 clock cycle. When the TPS_INFO_CHANGE interrupt is enabled and this event occurs, the DTTV demodulator generates an interrupt to the external microcontroller. The rule for the TPS_INFO_CHANGE applies to all TPS data bits except for the frame number.

HIERARCHY COFDM Nonuniform Constellation Ratio R/W [4:2]

When this register is read, these bits provide the last value received by the channel, using the TPS signalling information.

When this register is written, these bits store the next Constellation expansion ratio that the system uses. The values are:

HIERARCHY[2:0]	Definition
000	Nonhierarchical
001	$\alpha = 1$
010	$\alpha = 2$
011	$\alpha = 4$
100	Reserved
101	Reserved
110	Reserved
111	Reserved

The initial condition for the HIERARCHY is 0b000 (Nonhierarchical).

QAMTYPE **Constellation Type** **R/W [1:0]**

When this register is read, these bits provide the last value received by the channel, using the TPS signalling information.

When this register is written to, these bits store the next Constellation Type value that the system uses. The values are:

QAMTYPE[1:0]	Definition
00	QPSK
01	16 QAM
10	64 QAM
11	reserved

The initial condition for the QAMTYPE is 0b10 (64 QAM).

4.4 Parameter Registers

The Parameter registers contain configuration information. If the registers are read, they indicate the current parameter value. These Parameter registers are only configurable through the microprocessor.

4.4.1 Address Line 0x05

	7	6	5	4	3	2	0
0x05	AFC_CLIPPING	AFC_MODE	AFC_FINE_MODE	AFC_STALL	AFC_POL	AFC_SENSITIVITY	

AFC_CLIPPING

AFC Loop Bandwidth Limiter **R/W 7**

This bit selects the combination method between the Fine Algorithm part and the Coarse Algorithm part.

When using Method I (AFC_CLIPPING = 0), the combination is done by adding the two values. When the Coarse part is an integer number of carrier spacing, and the Fine part is a fraction of the carrier spacing, the result is the exact frequency offset.

When using Method II (AFC_CLIPPING = 1), the Fine part is only considered when the AFC Coarse value is 0.

If not, the value applied to the Tuner Oscillator (via the Sigma-Delta) is either +1 or -1. This limits the bandwidth of the system.

The initial condition for the AFC_CLIPPING bit is 1, which is Method II.

AFC_MODE AFC Muxin Mode R/W 6

When the MUXIN bus is connected to the AFC, this bit determines if the Symbol Number is coming from the OBC (Partial MUXIN Mode), as in Normal functional mode, or coming from the MUXIN bus itself (Full MUXIN Mode). If this bit is 0, the Symbol Number is coming from the Full MUXIN Mode; if this bit is 1, the Symbol Number is coming from the Partial MUXIN Mode.

The initial condition for the AFC_MODE is 0, the Full MUXIN mode. However, this has no effect if the default mode of AFC_MUXIN is 0 (which means that the AFC is taking its Symbol Number from the OBC no matter what the value of AFC_MODE is). See the definition of the MUXIN register for more information.

AFC_FINE_MODE

AFC Fine Algorithm Mode R/W 5

This bit determines if the AFC Fine Algorithm performs a weighted mean.

If the Weighted mean mode is chosen (this bit is 0), the AFC algorithm performs a weighted mean on the signal measurements to perform its Fine AFC calculation.

If the Unweighted mean mode is chosen (this bit is 1), the AFC algorithm does not perform a weighted mean on the signal measurements to perform its Fine AFC calculation.

The initial condition for this bit is 0, the Weighted Mean mode.

AFC_STALL AFC Loop Updating Freeze R/W 4

This bit determines if the AFC Loop is working or frozen.

If the Loop is working (0), the integrator inside the L64780 updates its value from time to time.

If the Loop is stalled (1), the integrator inside the L64780 keeps its internal value constant, enabling you to set the Frequency Offset by means of software (using AFC_INIT_FREQ).

The initial condition for the AFC_STALL is 0, the normal working mode.

AFC_POL AFC VCO Polarity R/W 3

These bits determine the polarity of the external VCO.

If the polarity is positive (this bit is 0), the output frequency of the external down-converter must increase with increasing voltage from the AFCOUT pin.

If the polarity is negative (this bit is 1), the output frequency of the external down-converter must decrease with increasing voltage from the AFCOUT pin.

The initial condition for the AFC_POL is 0 (positive).

AFC_SENSITIVITY

AFC Loop Gain R/W [2:0]

These bits adjust the AFC Gain of the Loop Filter. The value is set according to the sensitivity of the AFC input of the external down-converter. The values in digital AFC loop mode are:

AFC_SENSITIVITY[2:0]			Definition
0	0	0	$K_{SENS} \approx 1.52 \times 10^{-5}$
0	0	1	$K_{SENS} \approx 3 \times 10^{-5}$
0	1	0	$K_{SENS} \approx 6 \times 10^{-5}$
0	1	1	$K_{SENS} \approx 1.22 \times 10^{-4}$
1	0	0	$K_{SENS} \approx 2.44 \times 10^{-4}$
1	0	1	$K_{SENS} \approx 4.88 \times 10^{-4}$
1	1	0	$K_{SENS} \approx 9.8 \times 10^{-4}$
1	1	1	$K_{SENS} \approx 1.95 \times 10^{-3}$

The initial condition for these bits is 0b110, or

$$K_{SENS} \approx 9.8 \times 10^{-4}.$$

The values in Analog AFC loop mode are:

AFC_SENSITIVITY[2:0]			Definition
0	0	0	$K_{SENS} \approx 2.44 \times 10^{-4}$
0	0	1	$K_{SENS} \approx 4.88 \times 10^{-4}$
0	1	0	$K_{SENS} \approx 9.8 \times 10^{-4}$
0	1	1	$K_{SENS} \approx 1.95 \times 10^{-3}$
1	0	0	$K_{SENS} \approx 3.9 \times 10^{-3}$
1	0	1	$K_{SENS} \approx 7.8 \times 10^{-3}$
1	1	0	$K_{SENS} \approx 1.56 \times 10^{-2}$
1	1	1	$K_{SENS} \approx 3.1 \times 10^{-2}$

The initial condition for these bits is 0b110, or
 $K_{SENS} \approx 1.56 \times 10^{-2}$.

4.4.2 Address Lines 0x06, 0x07, 0x08

7	0
0x06	AFC_INIT_FRQ_LSB
0x07	AFC_INIT_FRQ_CSB
0x08	AFC_INIT_FRQ_MSB

AFC_INIT_FRQ

AFC Initial Frequency Offset

R/W [7:0]

These three 8-bit registers select the Initial Frequency Offset that is directed towards the Tuner or the DDFS block.

- When these registers are read, the resultant value represents the actual Frequency Offset (for example, the content of the integrator) recovered by the system.
- When this register is written, the resultant value reinitializes the Integrator value.
- Three OBC accesses are necessary to update these registers; thus, you should first stall the Integrator by setting AFC_STALL to 1, then update the values. You can reactivate the integrator by resetting AFC_STALL to 0.

The initial condition for these registers is 0.

4.4.3 Address Line 0x09

	7	6	5	4	3	2	1	0
0x09	SOFTBIT	BDI_ DISABLE	SDI_ DISABLE	DOF_OUTPUT_ FORMAT	DDFS_ DISABLE	DDFS_ MODE	ADCON	

SOFTBIT **Soft Decision Number of Bits** **R/W 7**
 This bit determines if a 3-bit (0) or a 4-bit (1) soft decision is used. The initial condition for this bit is 1.

BDI_DISABLE **BDI Disable** **R/W 6**
 If this bit is 1, the Bit Deinterleaver is disabled; if this bit is 0, the Bit Deinterleaver is enabled. The initial condition for this bit is 0, the Normal Operational Mode.

SDI_DISABLE **SDI Disable** **R/W 5**
 If this bit is 1, the Symbol Deinterleaver is disabled; if this bit is 0, the Symbol Deinterleaver is enabled. The initial condition for this bit is 0, the Normal Operational Mode.

DOF_OUTPUT_FORMAT **Chip Output Format** **R/W [4:3]**
 These bits select the output format of the L64780 towards the FEC decoder chip. The different formats are described in [Section 3.4, "Microprocessor Interface."](#)
 There are three modes:

- When in Nonhierarchical mode, two submodes are provided: Serial and Parallel. In Serial Mode, data is presented only on SD0. In Parallel Mode, data is presented on SD0 and SD1.
- When in Hierarchical mode with only one FEC chip, either the HP stream or the LP Stream is presented.

- When in Hierarchical mode with two FEC chips, HP and LP streams are presented on SD0 and SD1, respectively.

Hierarchical	DOF_OUTPUT_		Definition
	FORMAT[1:0]		
NO	X	0	Serial Mode
NO	X	1	Parallel Mode
YES	0	0	HP stream over SD0, 1 FEC Mode
YES	1	0	LP stream over SD0, 1 FEC Mode
YES	X	1	HP over SD0, LP over SD1, Two FEC Mode

The initial condition for these bits is 0b00.

DDFS_DISABLE

DDFS Disable

R/W 2

This bit determines if the DDFS performs the Baseband correction (0) or not (1). The initial condition for the DDFS_DISABLE is the Normal Operational Mode (0).

DDFS_MODE

DDFS Start Pulse Selector

R/W 1

If this bit is 0, the DDFS block gets its START Pulse (pulse delimiting every COFDM symbol) from the Timing Recovery Unit Block; if this bit is 1, the DDFS block gets its START Pulse from the MUXIN Block.

The initial condition value for the DDFS_MODE bit is 0.

The DDFS block can operate in four modes, as listed in [Table 4.2](#).

Table 4.2 DDFS Block Modes

DDFS Mode	DDFS Muxin	DDFS Disable	Functional Mode
X	0	0	Normal
0	1	0	Test
1	1	0	Down-Converter Off-Chip
X	X	1	Disable Mode

When in Normal mode, the L64780 receives a real signal in the intermediate frequency (about 4.5 MHz), and the R2C block performs the baseband conversion. In this mode, the DDFS block receives a complex baseband signal directly from the R2C block and takes the DDFS_XIN, DDFS_YIN, and DDFS_DVIN signals and the symbol synchronization DDFS_STARTIN signal from the Timing synchronization (TIM) block.

In Down-Converter Off-Chip mode, the baseband conversion is done by the tuner, but the COFDM symbol synchronization signal is still provided by the TIM block. In this mode, the DDFS block takes the DDFS_XOFF, DDFS_YOFF, and DDFS_DVOFF signals from the off-chip interface, whereas the symbol synchronization DDFS_STARTIN signal comes from the TIM block (see [Section 3.2.1, “Access to Timing and DDFS Blocks,” page 3-10](#), for the DDFS_XOFF, DDFS_YOFF, and DDFS_DVOFF signals mapping into the MUXIN bus).

When in Test mode, the DDFS block receives the baseband complex data and the symbol synchronization from the off-chip interface. In this mode, the DDFS_XOFF, DDFS_YOFF, DDFS_DVOFF, and DDFS_STARTOFF signals come from the off-chip interface. (See [Section 3.2.1, “Access to Timing and DDFS Blocks,” page 3-10](#), for the DDFS_XOFF, DDFS_YOFF, and DDFS_DVOFF and DDFS_STARTOFF signals mapping into the MUXIN bus.)

In Disable mode, only the DDFS_XIN, DDFS_YIN, DDFS_DVIN, and DDFS_STARTIN signals are used; no frequency shift is applied to the incoming complex data, but the data processing time latency must be preserved.

ADCON	ADC Selector	R/W 0
	This bit determines if the L64780 uses the 8-bit on-chip (1), or the external 10-bit (0) ADC. The initial condition for the ADCON is 0, the external 10-bit ADC.	

4.4.4 Address Line 0x0A

	7	5	4	3	2	0
0x0A	AGC_TARGET_LSB	AGC_DISABLE	AGC_POL	AGC_GAIN		

AGC_TARGET_LSB

AGC Target RMS Value (LSB)

R/W [7:5]

These bits select the LSBs of the Target RMS value of the AGC Loop (see [Section 2.3.1, "AGC Target RMS Value"](#)). The initial condition for these bits is 0b100.

AGC_DISABLE

AGC Disable

R/W 4

This bit determines if the AGC is disabled (1) or not (0). The initial condition for the AGC_DISABLE bit is 0, Normal Operational Mode.

AGC_POL

AGC Loop Polarity

R/W 3

This bit selects the polarity of the external AGC Loop.

If the polarity is positive (this bit is 0), the gain of the external down-converter must increase with increasing voltage from the AGCOUT pin.

If the polarity is negative (this bit is 1), the gain of the external down-converter must decrease with increasing voltage from the AGCOUT pin.

The initial condition for the AGC_POL is 1, negative.

AGC_GAIN **AGC Loop Gain** **R/W [2:0]**
 These bits adjust the AGC Gain of the Loop Filter. The value is set according to the sensitivity of the AGC loop. The values are:

AGC_GAIN[2:0]			Definition
0	0	0	$K_s \approx 3.9 \times 10^{-3}$
0	0	1	$K_s \approx 9.8 \times 10^{-4}$
0	1	0	$K_s \approx 2.4 \times 10^{-4}$
0	1	1	$K_s \approx 6.1 \times 10^{-5}$
1	0	0	$K_s \approx 1.5 \times 10^{-5}$
1	0	1	$K_s \approx 3.8 \times 10^{-6}$
1	1	0	$K_s \approx 9.5 \times 10^{-7}$
1	1	1	$K_s \approx 2.4 \times 10^{-7}$

The initial condition for these bits is 0b011, $K_s \approx 6.1 \times 10^{-5}$.

4.4.5 Address Line 0x0B

7	6	5	0
0x0B	ADC_FORMAT	R2C_SI	AGC_TARGET_MSB

ADC_FORMAT

Format of ADC Output R/W 7

This bit determines if the ADC outputs its values in two's complement (1) or in binary offset format (0). The initial condition for the ADC_FORMAT bit is 0, binary offset.

R2C_SI

COFDM Spectrum Inversion R/W 6

During the up-conversion and the following down-conversion, the COFDM spectrum can be inverted, depending on the equipment used. This bit determines if the COFDM signal should be spectrally inverted (1) or not (0).

The initial condition for the R2C_SI bit is 0, normal operation.

This spectrum inversion changes the sign of the sine function (negative for 0, positive for 1).

AGC_TARGET_MSB

AGC Target RMS Value (MSB)

R/W [5:0]

These bits select the MSBs of the Target RMS value of the AGC Loop (see [Section 2.3.1, “AGC Target RMS Value”](#)).

The initial condition for these bits is 0x0E.

4.4.6 Address Line 0x0C

	7	5	4	2	1	0
0x0C	TIM_LOOP_I		TIM_LOOP_P		TIM_IIRGAIN	

TIM_LOOP_I Timing Gain Loop 2

R/W [7:5]

These bits adjust the Timing Gain of the Loop Filter. The value is set according to the sensitivity of the VXCO loop.

TIM_LOOP_I[2:0]			Definition
0	0	0	$K_I \approx 0.125$
0	0	1	$K_I \approx 3.125 \times 10^{-2}$
0	1	0	$K_I \approx 7.8 \times 10^{-3}$
0	1	1	$K_I \approx 1.95 \times 10^{-3}$
1	0	0	$K_I \approx 4.8 \times 10^{-4}$
1	0	1	$K_I \approx 1.22 \times 10^{-4}$
1	1	0	$K_I \approx 3 \times 10^{-5}$
1	1	1	$K_I \approx 7.63 \times 10^{-6}$

The initial condition for the TIM_LOOP_I is 0b011 (Gain 3) $K_I \approx 1.95 \times 10^{-3}$.

TIM_LOOP_P

Timing Gain Loop 1

R/W [4:2]

These bits adjust the Timing Gain of the Loop Filter. The value is set according to the sensitivity of the VXCO loop.

TIM_LOOP_P[2:0]			Definition
0	0	0	$K_P \approx 8.0$
0	0	1	$K_P \approx 4.0$
0	1	0	$K_P \approx 2.0$
0	1	1	$K_P \approx 1.0$
1	0	0	$K_P \approx 0.5$
1	0	1	$K_P \approx 0.25$
1	1	0	$K_P \approx 0.125$
1	1	1	$K_P \approx 6.25 \times 10^{-2}$

The initial condition for the TIM_LOOP_P is 0b011 (Gain 3) $K_P \approx 1.0$.

TIM_IIRGAIN Timing IIR Filter Time Constant

R/W [1:0]

These bits govern the amount of IIR Filtering done in the Timing Loop Filter.

TIM_IIRGAIN[1:0]		Definition
0	0	$\alpha \approx 6.25 \times 10^{-2}$
0	1	$\alpha \approx 3.125 \times 10^{-2}$
1	0	$\alpha \approx 1.56 \times 10^{-2}$
1	1	$\alpha \approx 7.8 \times 10^{-3}$

The initial condition for the TIM_IIRGAIN is 0b01 (Gain 1) $\alpha \approx 3.125 \times 10^{-2}$.

4.4.7 Address Line 0x0D

7	0
0x0D	TIM_OFFSET_LSB

TIM_OFFSET_LSB

Start Pulse Phase Offset (LSB)

R/W [7:0]

The start pulse is a signal with a periodicity of every FFT-MODE+GUARD 9 MHz cycles (in steady state). The TIM_OFFSET bits adjust the phase of this signal in the periodic window. The initial condition for the TIM_OFFSET_LSB bits is 0x00.

4.4.8 Address Line 0x0E

7	6	5	0
0x0E	TIM_STALL	TIM_POL	TIM_OFFSET_MSB

TIM_STALL

TIM Loop Updating Freeze

R/W 7

This bit determines if the Loop is working (this bit is 0) or stalled (this bit is 1).

If the Loop is working, the integrator inside the L64780 updates its value.

If the Loop is stalled, the integrator inside the L64780 keeps its internal value constant, letting you set the VCXO Frequency Offset by means of the TIM_CLK_INIT bits.

The initial condition for the TIM_STALL bit is 0, normal working mode.

TIM_POL

TIM VCXO Polarity

R/W 6

This bit determines the polarity of the external VCXO:

- If the polarity is positive (this bit is 0), the output frequency of the external VCXO increases with increasing voltage from VCXOUT.
- If the polarity is negative (this bit is 1), the output frequency of the external VCXO decreases with increasing voltage from VCXOUT.

The initial condition for the TIM_POL is 1, negative polarity.

TIM_OFFSET_MSB

Start Pulse Phase Offset (MSB)

R/W [5:0]

The start pulse is a signal with a periodicity of every FFT-MODE + GUARD 9 MHz cycles (in steady state). The TIM_OFFSET bits adjust the phase of this signal in the periodic window. The initial condition for these bits is 0x00.

4.4.9 Address Lines 0x0F, 0x10

	7	0
0x0F	TIM_CLK_INIT_LSB	
0x10	TIM_CLK_INIT_MSB	

TIM_CLK_INIT

Timing Initial VCXO Offset

R/W [7:0]

These two registers, TIM_CLK_INIT_LSB and TIM_CLK_INIT_MSB, select the initial VCXO frequency offset that is directed to the external VCXO.

When this register is read, its value represents the actual VCXO offset (for example, the content of the integrator) recovered by the system.

When this register is written, this value reinitializes the Integrator value.

Two OBC accesses are required to update these registers; thus, you should first stall the Integrator by setting TIM_STALL to 1, then update the values. The process can be unfrozen by clearing TIM_STALL back to 0.

The initial condition for these bits is 0x00 (both registers set to 0x00).

4.4.10 Address Line 0x11

	7	6	5	4	3	2	1	0
0x11	CPE_DISABLE	CE_DISABLE	CE_DISABLE_ETS	CE_TEMPOTYPE	CE_SELECT	FFT_DIR	FFT_GAIN	

CPE_DISABLE

Common Phase Error Disable **R/W 7**

This bit determines if the CPE is disabled (1) or not (0). The initial condition for this bit is 0, normal operation.

CE_DISABLE CE Disable **R/W 6**

This bit determines if the CE is disabled (1) or not (0). The initial condition for this bit is 0, normal operation.

CE_DISABLE_ETS

CE Timing Shift Disable **R/W 5**

The Channel Equalizer emulates a negative echo to ease implementation. If this bit has a value of 1, the negative echo generation is disabled. If this bit is set to 0, the negative echo generation is enabled. The initial condition for this bit is 0, Working Mode.

CE_TEMPOTYPE

CE Timing Interpolation Type **R/W 4**

This bit selects the mode of operation of the Channel Equalizer Timing Interpolation. If this bit is 0, the mode is Zero Order Hold; if this bit is 1, the mode is Linear. The initial condition for this bit is 1, Linear.

CE_SELECT CE MUXOUT Selector **R/W 3**

When MUXOUT is selected to output the Channel Equalizer value, either the Channel Response (1) or the Equalized Data (0) can be output. Note that both cases do not affect receiver functionality. The initial condition for this bit is 0, Equalized Data.

FFT_DIR FFT Direction **R/W 2**

This bit determines if the FFT is in Forward mode (Timing to Frequency Domain, 0) or Backward mode (Frequency to Timing Domain, 1). For L64780 normal operational mode, the FFT direction is Forward. The initial condition for the FFT_DIR is 0, Forward.

FFT_GAIN **FFT Clipping and Rounding** **R/W [1:0]**
 This register selects how the FFT clips and rounds in case of overflow. The values are:

FFT_GAIN[1:0]		Definition
0	0	Gain 0
0	1	Gain 1
1	0	Gain 2
1	1	Gain 3

The initial condition for these bits is 0b10, Gain 2.

4.4.11 Address Line 0x12

0x12	RES	CSI_OUT_FORMAT	CSI_IIRATE
------	-----	----------------	------------

RES **Reserved** **[7:3]**
 These bits are reserved.

CSI_OUT_FORMAT **CSI Softbits Format** **R/W 2**
 This bit allows the generation of softbit values either in two's complement (1) or in binary offset (0). The initial condition for this bit is 0, binary offset.

CSI_IIRATE **CSI IIR Filter Gain** **R/W [1:0]**
 These bits set the IIR Gain of the Channel State Information Unit. The values are:

CSI_IIRATE[1:0]		Definition
0	0	Gain 0
0	1	Gain 1
1	0	Gain 2
1	1	Gain 3

The initial condition for the CSI_IIRATE is 0b01, Gain 1.

4.4.12 Address Line 0x13

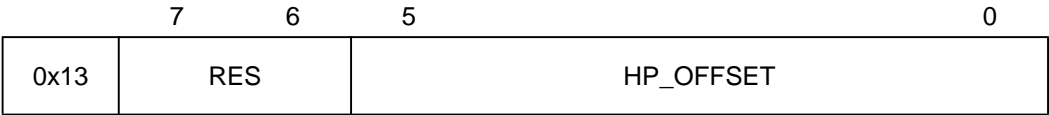

RES **Reserved** **[7:6]**
 These bits are reserved.

HP_OFFSET **CSI HP Stream Quantizer Gains** **R/W [5:0]**
 These bits set the Quantizer Gain of the Channel State Information Unit for the High-Priority stream. The initial value for the HP_OFFSET bits is 0x36.

4.4.13 Address Line 0x14

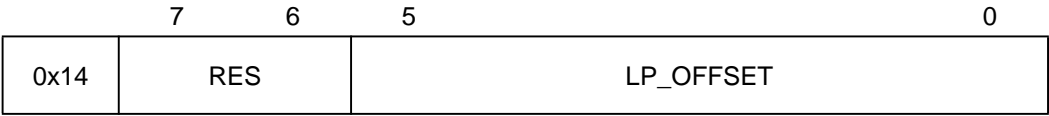

RES **Reserved** **[7:6]**
 These bits are reserved.

LP_OFFSET **CSI LP Stream Quantizer Gains** **R/W [5:0]**
 These bits set the Quantizer Gain of the Channel State Information Unit for the Low-Priority stream. The initial value for the LP_OFFSET is 0x36.

4.5 Mux Register Address Line 0x15

This register brings data to and from specific blocks. The MUXIN register is directly output from the OBC and goes to the Clock generator block.

	7	6	5	3	2	0
0x15	RES		MUXIN		MUXOUT	

RES **Reserved** **[7:6]**
 These bits are reserved.

MUXIN **MUXIN Selector** **R/W [5:3]**
 These bits select the point in the system to be driven through the MUXIN input pins and the CLKMUXIN clock to sample the data coming into the L64780. There are six possibilities:

MUXIN	Definition	Muxin Clock
000	Normal Mode	Set LOW
001	MUXIN inputs to Timing and DDFS Block	18 MHz
010	MUXIN inputs to AFC Block	36 MHz
011	MUXIN inputs to FFT Block	36 MHz
100	MUXIN inputs to CSI Block	18 MHz
101	MUXIN inputs to SDI Block	18 MHz
110	unused	Set LOW
111	unused	Set LOW

The initial value for MUXIN is 0b000 (no MUXIN).

[Table 4.3](#) defines how to set the different MUXIN signals and the Muxin clock.

Table 4.3 MUXIN Signal Settings and MUXIN Clock

MUXIN	TIM Muxin	DDFS Muxin	AFC Muxin	FFT Muxin	CSI Muxin	SDI Muxin	Muxin Clock
000	0	0	0	0	0	0	Set LOW
001	1	1	0	0	0	0	CLK18
010	0	0	1	0	0	0	CLK36
011	0	0	0	1	0	0	CLK36
100	0	0	0	0	1	0	CLK18
101	0	0	0	0	0	1	CLK18
110	0	0	0	0	0	0	Set LOW
111	0	0	0	0	0	0	Set LOW

MUXOUT

MUXOUT Selector

R/W [2:0]

These bits select the point in the system to be monitored through the output block. There are six possibilities:

MUXOUT[2:0]			Definition
0	0	0	DDFS Output Presented
0	0	1	FFT Output Presented
0	1	0	AFC Output Presented
0	1	1	CE Output Presented
1	0	0	CSI Output Presented
1	0	1	AFC Output Presented
1	1	0	unused
1	1	1	unused

The initial value for these bits is 0b011, CE Output.

4.6 Performance Monitoring Registers Address Line 0x16

These registers contain the aggregate statistical and monitoring information available to the OBC block.

	7	6	5	4	3	2	1	0
0x16	RES	FRAME_SYNC_OK	TPS_SYNC_OK	AFC_SYNC_OK	TIM_CLK_SYNC_OK	TIM_START_SYNC_OK	TIM_START_SYNC_OK	SYNC_OK

RES **Reserved** **[7:6]**
 These bits are reserved.

FRAME_SYNC_OK **COFDM Frame Synchronization** **R/W 5**
 If the frame synchronization in the DTTV demodulator is correct, this bit is 1 (ODFM frame is locked). If this bit is 0, the COFDM frame is unlocked. The initial condition for this bit is 1, locked.

TPS_SYNC_OK **TPS Synchronization** **R/W 4**
 If the BCH code in the TPS indicates that the TPS is valid, this bit is 1 (TPS is locked). If this bit is 0, TPS is unlocked. The initial condition for this bit is 1, locked.

AFC_SYNC_OK **AFC Synchronization** **R/W 3**
 If the frequency synchronization in the DTTV demodulator is correct, this bit is 1 (AFC locked); otherwise, it is 0 (unlocked). The initial condition for this bit is 1, locked.

TIM_CLK_SYNC_OK **Timing Synchronization** **R/W 2**
 If the sampling frequency synchronization in the DTTV demodulator is correct, this bit is 1 (VCXO is locked); otherwise, it is unlocked. The initial condition for this bit is 1, locked.

TIM_START_SYNC_OK

Start Pulse Synchronization

R/W 1

If the start FFT window synchronization (start pulse is locked) in the DTTV demodulator is correct, this location is 1; otherwise, the start pulse is unlocked. The initial condition for this bit is 1, locked.

SYNC_OK

Overall Chip Synchronization

R/W 0

If all aspects of the DTTV demodulator are synchronized, this bit is 1. If this bit is 0, at least one unit is not locked. The initial condition for this bit is 1, locked.

4.6.1 Address Line 0x17

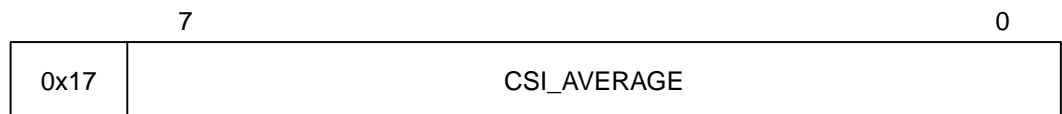

CSI_AVERAGE

CSI Reliability Average

R [7:0]

This register indicates the overall reliability of the carriers by making an average (integer number) of the reliability of each carrier.

4.6.2 Address Line 0x18

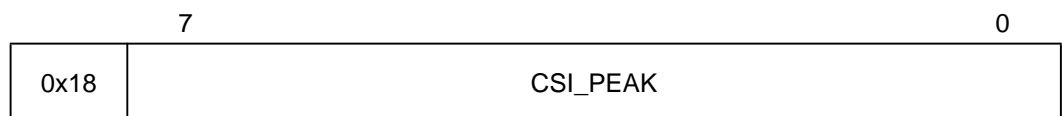

CSI_PEAK

CSI Reliability Peak

R [7:0]

This register gives the integer number of carriers when the value of the filtered Channel State Information exceeds a given threshold. If more than 255 carriers exceed this value, then 255 is returned.

4.7 Mode Register Address Line 0x19

This register influences how the DTTV demodulator operates.

	7	6	5	4	3	2	1	0
0x19	RES	ODRAIN_CTRL	WIRES3_CTRL	SD_CTRL	MUX_CTRL	SOFT_RESET	AUTO_MODE_ENABLE	CHANGE_MODE

RES **Reserved** **7**
This bit is reserved.

ODRAIN_CTRL

Output Drain Controller **R/W 6**

This bit allows the 3-Wire Bus pins to be set in Open Drain Mode. When this bit is 1, the 3-wire output bus is working in open drain (1 => Z, 0 => 0). When this bit is 0, the bus is in normal mode. The initial condition for this bit is 1, Output Drain Mode.

The WIRES3_CTRL and ODRAIN_CTRL bits generate the OBC_WIRE3_CTRL[2:0] 3-state control signals, as specified in the following table.

OBC_WIRE3_OUT	ODRAIN_CTRL	WIRES3_CTRL	OUT
0	0	0	0
0	1	0	0
0	0	1	Z
0	1	1	Z
1	0	0	1
1	1	0	Z
1	0	1	Z
1	1	1	Z

WIRES3_CTRL

3-Wire Bus 3-State Controller **R/W 5**

When this bit is 1, the 3-Wires Bus pins are 3-stated. When this bit is 0, the bus pins are in normal mode. The initial condition for this bit is 0, normal mode.

SD_CTRL	Normal Output 3-State Controller When this bit is 1, all Normal pins are 3-stated. The initial condition for this bit is 0, normal mode.	R/W 4
MUX_CTRL	MUXOUT 3-State Controller When this bit is 1, all MUXOUT pins are 3-stated. The initial condition for this bit is 0, normal mode.	R/W 3
SOFT_RESET	Chip Soft Reset Setting this bit enables a hard reset of the L64780 logic (except the OBC registers, which keep their values). This allows a proper reset of the chip in any default configuration (memories are also reset to 0). Note that the Soft Reset must be asserted from the external microcontroller; it is not a pulse. When this bit is 1, soft reset is enabled. When this bit is 0, no soft reset is possible.	R/W 2
AUTO_MODE_ENABLE	TPS Auto Updating This bit determines if the TPS updating is controlled by the external microcontroller, or if the Active registers are automatically updated each time new value TPS arrive from the Broadcaster. If this bit is 1, the current mode (as defined by the TPS register) of the demodulator is updated whenever a valid TPS is received. If this bit is 0, manual configuration of the TPS register is required. The initial condition for this bit is 0, Manual Update.	R/W 1
CHANGE_MODE	TPS Updating Register When a new mode of operation has been written into the TPS register, writing the value 1 into this location causes the demodulator to change mode. See Section 4.3, “TPS Registers,” page 4-11 for more information.	W 0

4.8 3-Wires Register Address Line 0x1A

The 3-wires register emulates the 3-Wires Bus protocol and controls the tuner. It can also be used to emulate a software I²C interface towards the tuner.

	7	6	5	3	2	0
0x1A	RES		WIRES3_IN		WIRES3_OUT	

RES **Reserved** **[7:6]**
These bits are reserved.

WIRES3_IN **3-Wires Input** **R/W [5:3]**
These bits collect the information coming from the 3-Wires off-chip inputs. The initial condition for WIRES3_IN is 0x0.

WIRES3_OUT **3-Wires Output** **R/W [2:0]**
These bits are directly presented off-chip to the control Tuner. The initial condition for WIRES3_OUT is 0x0.

Chapter 5

Signal Descriptions

This chapter describes the L64780 signals. These signals are grouped by function. Within each group, the signals are described in alphabetical order. This chapter consists of the following sections:

- Section 5.1, “Overview,” page 5-1
- Section 5.2, “Microprocessor Interface,” page 5-3
- Section 5.3, “Main Signals,” page 5-4
- Section 5.4, “Sigma-Delta Outputs,” page 5-6
- Section 5.5, “MUX Signals,” page 5-6
- Section 5.6, “3-Wires Signals,” page 5-7
- Section 5.7, “JTAG Signals,” page 5-7
- Section 5.8, “Test Pins,” page 5-8
- Section 5.9, “ASIC Pins,” page 5-8
- Section 5.10, “PLL Pins,” page 5-8
- Section 5.11, “Tester Pins,” page 5-9

5.1 Overview

Figure 5.1 provides the logic symbol for the L64780.

Figure 5.1 L64780 Logic Symbol

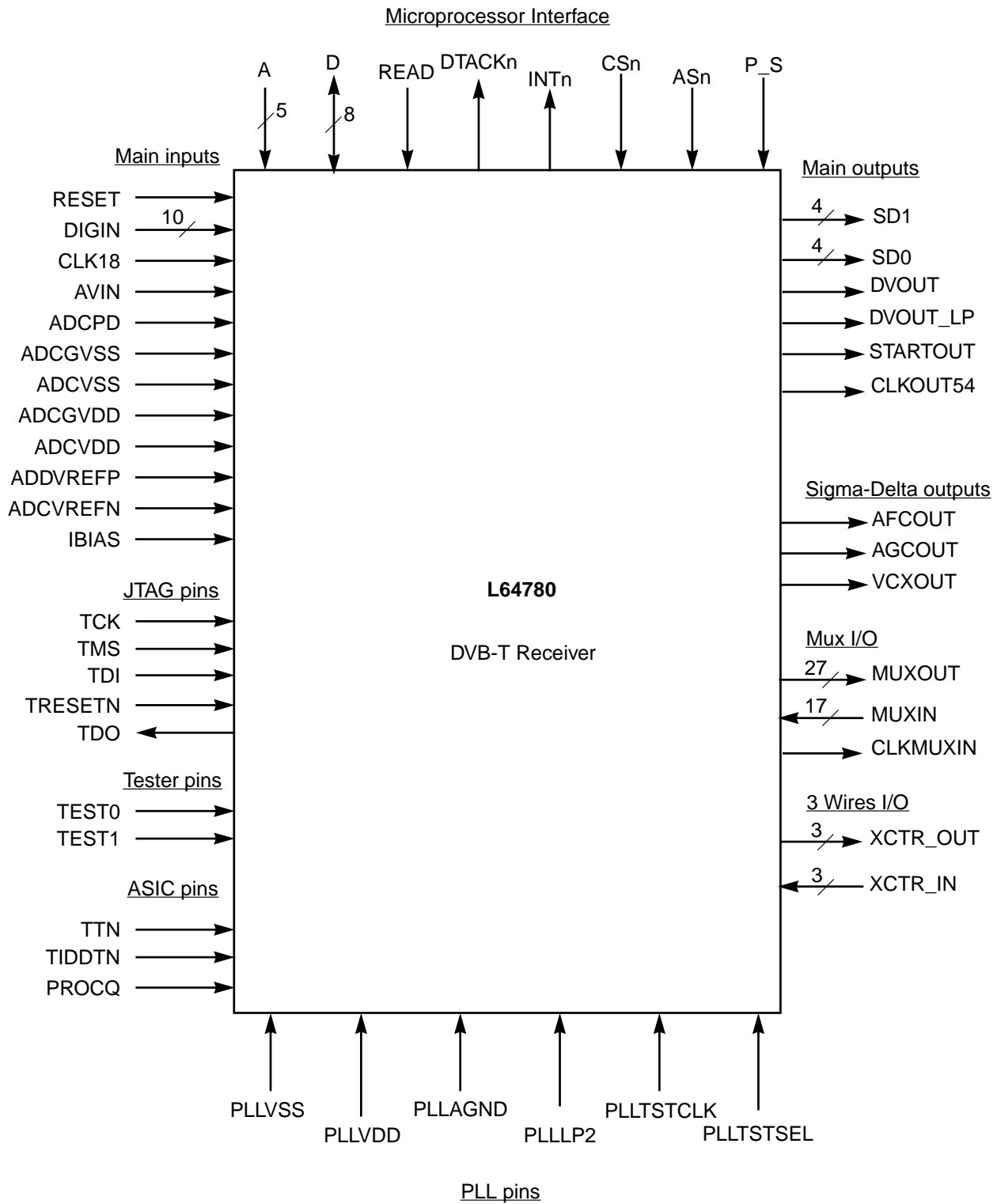

5.2 Microprocessor Interface

This section lists and describes the microprocessor interface signals.

Note that the parallel interface mode is used for LSI Logic internal testing and is not intended for use in customer production receivers. The serial mode interface is used for production systems.

A[4:0]	Address Bus	I
	The DTTV receiver has a five-bit address bus, A[4:0], that is used with an eight-bit data bus, D[7:0], a read/write strobe, Read, an address strobe, ASn, and a chip select strobe, CSn, to read and write internal registers. The address lines select internal registers. In Serial Mode, A0 is used as the serial clock, and A[4:1] must be connected to ground.	
ASn	Address Strobe	I
	Active LOW address strobe input. Latches the address on the A[4:0] bus on the falling edge. In Serial interface mode, ASn must be connected to VDD.	
CSn	Chip Select	I
	Active LOW chip select strobe input. During a read cycle, CSn must be LOW to access the on-chip data registers. During a read access, the external controller can latch the data from the DTTV receiver with the rising edge of CSn. During a write access, CSn must go LOW prior to data being valid from the external controller to the DTTV receiver. In Serial Interface mode, CSn must be connected to VDD.	
D[7:0]	Microprocessor Data Bus	I/O
	This bidirectional bus is used as an input when data is written to the chip, and as an output when the chip is read. When the L64780 is not being read or written to, the data lines are 3-stated. In Serial Interface Mode, D0 is used as the serial data, and D[7:1] are used for the programmable Serial Bus interface.	
DTACKn	Data Transaction Acknowledge	O
	Active LOW output indicating that the transaction has been completed. When not driven, the line is open-drain 3-stated.	

INTn	Interrupt The DTTV receiver asserts INTn when an internal, unmasked interrupt flag is set. INTn remains asserted as long as the interrupt condition persists and the interrupt flag is not masked. When not driven, the line is open-drain 3-stated.	O
P_S	Microprocessor Operation Mode When this signal is LOW, operation is Parallel Mode; when HIGH, operation is Serial Mode.	I
READ	Read Strobe When HIGH, a read operation is selected; when LOW, a write operation is selected. In Serial interface mode, READ must be connected to VDD.	I

5.3 Main Signals

This section lists and describes the main signals input to the L64780 or output to the L64705/L64724.

ADCGVDD	Guard VDD for Internal ADC Must be connected to VDD.	I
ADCGVSS	Internal ADC Guard VSS Must be connected to ground.	I
ADCPD	Power-Down Mode for Internal ADC This pin is active HIGH and in normal mode must be connected to ground.	I
ADCVDD	Analog VDD for Internal ADC Must be connected to VDD.	I
ADCVREFN	Internal ADC Negative Reference Voltage When not used, this pin must be connected to ground.	I
ADCVREFP	Internal ADC Positive Reference Voltage When not used, this pin must be connected to ground.	I
ADCVSS	Analog VSS for Internal ADC Must be connected to ground.	I
AVIN	Analog Input for Internal ADC For an external ADC, this pin must be connected to ground.	I

CLK18	18 MHz Clock	I
	This is the 18 MHz input clock coming from the external VCXO.	
CLKOUT54	54 MHz Clock	O
	This is the 54 MHz clock output and is used to clock the L64705 or the L64724.	
DIGIN[9:0]	Digital Inputs	I
	Digital inputs in normal mode when a 10-bit off-chip ADC is used. DIGIN0 represents the LSB, while DIGIN9 represents the MSB. This bus is latched with the CLK18 clock. In MUXIN mode, DIGIN[9:0] represents the 10 LSBs of the 27 MUXIN bits, with DIGIN[0] mapped to MUXIN0, and DIGIN9 to MUXIN9. For an on-chip ADC, this bus must be connected to ground.	
DVOUT	SD0 Data Valid Out	O 3-State
	When asserted HIGH, this signal validates the SD0[3:0] bus.	
DVOUT_LP	SD1 Data Valid Out	O 3-State
	When asserted HIGH, this signal validates the SD1[3:0] bus.	
IBIAS	Input Bias Current for Internal ADC	I
	When not used, this pin must be connected to ground.	
RESET	Reset	I
	Hard reset. This pin is active-HIGH. See Section Table 6.6, "Reset AC Timing Parameters," page 6-5 , for the minimum and maximum assertion time for a valid reset.	
SD0[3:0]	SD0 Bus	O 3-State
	The first 4-bit output bus used to output the high- and low-priority streams.	
SD1[3:0]	SD1 Bus	O 3-State
	The second 4-bit output bus used to output the high- and low-priority streams.	
STARTOUT	First Soft Decision Mark	O 3-State
	When asserted HIGH, this signal marks the first soft decision of an COFDM symbol to be presented off-chip.	

5.4 Sigma-Delta Outputs

This section lists and describes the output signals to the L64705/L64724.

AGCOUT	AGC Output Sigma-Delta output of the AGC.	O Open Drain
VCXOUT	Sigma Delta output of the VCXOUT.	O Open Drain
AFCOUT	AFC Output Sigma Delta output of the AFCOUT.	O Open Drain

5.5 MUX Signals

This section lists and describes the MUX input and output signals.

This interface is used for LSI Logic internal testing and is not intended for use in customer production receivers.

MUXIN[16:0]	Muxin Bus This bus is combined with the 10-bit ADCIN[9:0] to form a 27-input MUXIN bus. When not used, this bus must be connected to ground.	I Pull-Down
CLKMUXIN	Clock for MUXIN This pin provides the clock to latch the MUXIN bus.	I Clock
MUXOUT[26:0]	MUX Test Bus This 27-input bus is used for testing.	O 3-State

5.6 3-Wires Signals

This section lists and describes the 3-wire signals.

XCTR_OUT[2:0]

Tuner Control Output

O 3-State

These three output pins are mainly used to control the tuner and are directly controlled through the microprocessor.

XCTR_IN[2:0] **Tuner Control Input**

I

These three input pins collect information from the tuner. When not used, these pins must be connected to ground.

5.7 JTAG Signals

This section lists and describes the JTAG signals.

TCK

JTAG TAP Clock

I Pull-Up

When in normal operating mode, this pin must be connected to VDD.

TDI

JTAG TAP Test Data Input

I Pull-UP

When in normal operating mode, this pin must be connected to VDD.

TDO

JTAG TAP Test Data Output

O 3-State

JTAG TAP Test Data output.

TMS

JTAG TAP Test Mode Select

I Pull-Up

When in normal operating mode, this pin must be connected to VDD.

TRESETN

JTAG TAP Reset

I Pull-Up

When in normal operating mode, this pin must be connected to VDD.

5.8 Test Pins

This section lists and describes the test signals.

TEST0	Test Selection 0 This pin is used for test selection. When in normal operating mode, this pin must be connected to ground.	I
TEST1	Test Selection 1 This pin is used for test selection. When in normal operating mode, this pin must be connected to ground.	I

5.9 ASIC Pins

This section lists and describes the ASIC signals.

TTn	This pin is active LOW and controls all the output pins. In normal operating mode, it must be connected to VDD.	I
TIDDTN	This pin is active HIGH. In normal operating mode, it must be connected to ground.	I
PROCQ	Dedicated output for ASIC characterization.	O

5.10 PLL Pins

This section lists and describes the PLL signals.

PLLVSS	Ground for Internal PLL This signal must be connected to ground.	I
PLLVDD	VDD for Internal PLL This signal must be connected to VDD.	I
PLLAGND	Analog Ground for Internal PLL This signal must be connected to ground.	I
PLLLP2	VCO Voltage Control This signal must be connected to the external filter.	I

5.11 Tester Pins

This section lists and describes the internal tester signals.

PLLSTCLK

Pin dedicated to internal test purposes. In normal operating mode, this pin must be connected to ground. |

PLLSTSEL

Pin dedicated to internal test purposes. In normal operating mode, this pin must be connected to ground. |

Chapter 6

Specifications

This chapter describes the electrical specifications, power requirements, DC characteristics, and AC timing parameters for the L6780. It consists of the following sections:

- Section 6.1, “Electrical Specifications,” page 6-1
- Section 6.2, “AC Timing,” page 6-4
- Section 6.3, “Signal Specifications,” page 6-6
- Section 6.4, “Pinouts,” page 6-11
- Section 6.5, “Mechanical Drawing,” page 6-15

6.1 Electrical Specifications

This section specifies the electrical requirements for L64780.

[Table 6.1](#) lists the absolute maximum ratings for the L64780.

Table 6.1 Absolute Maximum Ratings

Parameter	Symbol	Limits ¹	Unit
DC Supply Voltage	V_{DD}	-0.3 to +3.9	V
LVTTL Input Voltage	V_{IN}	-1.0 to $V_{DD} + 0.3$	V
5 V Compatible Input Voltage	V_{IN}	-1.0 to 6.5	V
DC Input Current	I_{IN}	± 10	mA
Storage Temperature Range (Plastic)	T_{STG}	-40 to +125	°C

1. The ratings in this table are those beyond which permanent device damage is likely to occur. These values should not be used as the limits for normal device operation.

Table 6.2 lists the recommended operating conditions for the L64780.

Table 6.2 Recommended Operating Conditions

Parameter	Symbol	Limits ¹	Unit
DC Supply Voltage	V_{DD}	+3.0 to +3.6	V
Operating Ambient Temperature Range	T_A	0 to +70	°C

1. For normal device operation, adhere to the limits in this table. Sustained operation of the device at conditions exceeding these values, even if they are within the absolute maximum rating limits, can result in permanent device damage or impaired device reliability. Device functionality to stated DC and AC limits is not guaranteed if conditions exceed recommended operating conditions.

Table 6.3 lists the DC characteristics of L64780, which is produced with the LCBG10p process. This is a 0.35-micron drawn gate length cell-based process. Characteristics in the table are the same for any device that has a buffer with the listed parameters.

Table 6.3 DC Characteristics

Symbol	Parameter	Condition	Min	Typ	Max	Unit
V_{DD}	Supply Voltage		3.0	3.3	3.6	V
V_{IL}	Input Low Voltage		$V_{SS} - 0.5$		0.8	V
V_{IH}	Input High Voltage	LVTTL Temp Range	2.0		$V_{DD} + 0.3$	V
		5-V Compatible	2.0		5.5	V
V_T	Switching Threshold			1.4	2.0	V
V_{T+}	Schmitt Trigger, Positive-going Threshold			1.7	2.0	V
V_{T-}	Schmitt Trigger, Negative-going Threshold		0.8	1.0		V
	Schmitt Trigger, Hysteresis		0.6	0.7		V
I_{IN}	Input Current Inputs with Pulldown Resistors Inputs with Pullup Resistors	$V_{IN} = V_{DD}$ or V_{SS}	-10	± 1	10	mA
		$V_{IN} = V_{DD}$	35	115	222	mA
		$V_{IN} = V_{SS}$	-35	-115	-214	mA

Table 6.3 DC Characteristics (Cont.)

Symbol	Parameter	Condition	Min	Typ	Max	Unit
V _{OH}	Output High Voltage					
	Type B1	I _{OH} = -1 mA ²	2.4		V _{DD}	V
	Type B2	I _{OH} = -2 mA ³	2.4		V _{DD}	V
	Type B4	I _{OH} = -4 mA ³	2.4		V _{DD}	V
	Type B6	I _{OH} = -6 mA ³	2.4		V _{DD}	V
	Type B8	I _{OH} = -8 mA ³	2.4		V _{DD}	V
	Type B12 ¹	I _{OH} = -12 mA ³	2.4		V _{DD}	V
V _{OL}	Output Low Voltage					
	Type B1	I _{OL} = 1 mA		0.2	0.4	V
	Type B2	I _{OL} = 2 mA		0.2	0.4	V
	Type B4	I _{OL} = 4 mA		0.2	0.4	V
	Type B6	I _{OL} = 6 mA		0.2	0.4	V
	Type B8	I _{OL} = 8 mA		0.2	0.4	V
	Type B12 ²	I _{OL} = 12 mA		0.2	0.4	V
I _{OZ}	3-state Output Leakage Current	V _{OH} = V _{SS} or V _{DD}	-10	± 1	10	mA
I _{OS}	Output Short Circuit Current ^{3, BT4}	V _O = V _{DD} V _O = V _{SS}			140 -40	mA mA
	Output Short Circuit, BT4F	V _O = V _{DD} V _O = V _{SS}			67 -86	mA mA
I _{DD}	Quiescent Supply Current	V _{IN} = V _{DD} or V _{SS}				
I _{CC}	Dynamic Supply Current		tbd			mA
C _{IN}	Input Capacitance ⁴	Input and Bidirectional Buffers	2.5			pF
		5-volt Compatible	3.0			pF
C _{OUT}	Output Capacitance ⁵	Output Buffer ⁵	2.0			pF
		5-volt Compatible	3.0			pF

1. Requires two output pads.
2. See the “Interfacing to 5 V Signals Using G10[®]-p Technologies” application note for “F” series output buffer I_{OH} values.
3. Type B4 output. Output short circuit current for other outputs will scale.
4. Excluding package capacitance.
5. Output using single buffer structure (excluding package).

6.2 AC Timing

The following subsections provide the AC timing for the input data interface and output data interface.

6.2.1 Input Data Interface

Figure 6.1 shows the waveform timing for the input data interface.

Figure 6.1 Input Data AC Timing

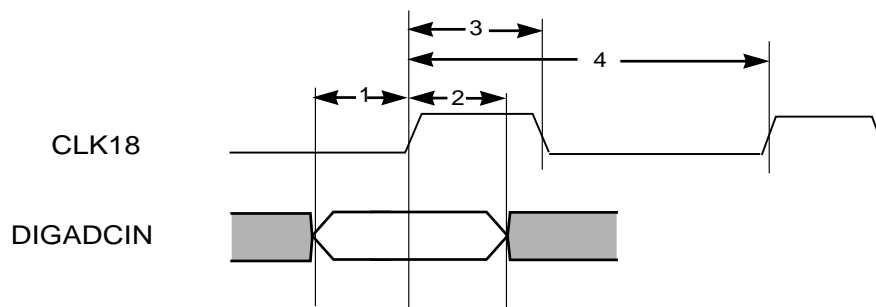

Table 6.4 lists the AC timings for the input data interface of the L64780.

Table 6.4 Input Data AC Timing Parameters

No.	Parameter	Description	Min	Max	Unit
1	t_s	Input Setup time to CLK18	6	–	ns
2	t_h	Input Hold time to CLK18	–	13	ns
3	t_{pwh}	Clock pulse width high	24.9	–	ns
4	t_{cycle}	Clock cycle time	55.5	–	ns

6.2.2 Output Data Interface

Figure 6.2 shows the waveform timing for the output data interface.

Figure 6.2 Output Data AC Timing

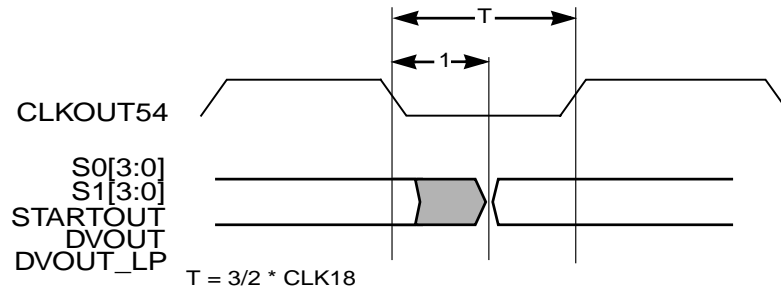

Table 6.5 lists the AC timing parameters for the output data interface of the L64780.

Table 6.5 Output Data AC Timing Parameters

	Parameter	Description	Min	Max	Unit
1	t_{od}	Output delay from CLKOUT54 falling edge	–	5.0	ns

6.2.3 Reset Timing

Figure 6.3 illustrates the reset timing for L64780. Table 6.6 lists and describes the output data AC timing parameters.

Figure 6.3 Reset Timing

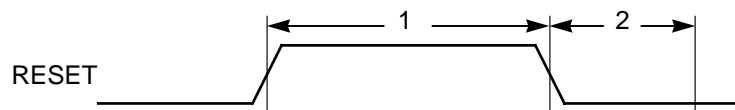

Table 6.6 Reset AC Timing Parameters

	Parameter	Description	Min	Max	Unit
1	t_{RWH}	Reset Pulse Width High	3	–	CLK18 cycles
2	t_{WK}	Wake-Up time (PLL acquisition time)	300	–	ms

6.3 Signal Specifications

Table 6.7 provides a summary of the pin numbers and their associated signals, grouped by function.

Table 6.7 Signal Summary List

Pin	Pin Name	Description	Buffer Type	5-Volt Compatible	Drive (mA)	Type	Active
Major I/Os							
99	CLK18	Input clock	LVTTL Input	Yes			–
20	RESET	Main Reset	LVTTL Input	Yes			High
34	CLKOUT54	Clock output to the L64705 or L64724	LVTTL Output	Yes			–
Microprocessor Interface							
125–9	A[4:0]	Address Bus ¹	LVTTL Input	Yes		Pull-Down	–
109–18	D[7:0]	Data Bus ²	LVTTL Bidir	Yes	4		–
108	READ	Read/Write selection	LVTTL Input	Yes		Pull-Up	–
107	CSn	Chip Select	LVTTL Input	Yes		Pull-Up	Low
106	ASn	Address Strobe	LVTTL Input	Yes		Pull-Up	Low
35	DTACKn	Data Acknowledge	LVTTL Output	Yes	4	3-State	Low
36	INTn	Interrupt	LVTTL Output	Yes	4	Open Drain	Low
105	P_S	Serial/Parallel Mode	LVTTL Input	Yes			–

Table 6.7 Signal Summary List (Cont.)

Pin	Pin Name	Description	Buffer Type	5-Volt Compatible	Drive (mA)	Type	Active
Main Input							
144–142, 139, 138, 135–133, 131, 130	DIGIN[9:0]	Digital Input in normal mode. Testin input otherwise	LVTTL Input	Yes		Pull-Down	–
152	ADCPD	ADC Power Down	Analog Input	Yes			HIGH
153	ADCGVSS	Guard VSS Supply	Analog Input	Yes			–
154	ADCVSS	Analog VSS supply	Analog Input	Yes			–
155	ADCVREFP	Positive Reference Voltage	Analog Input	Yes			–
156	ADCVREFN	Negative Reference Voltage	Analog Input	Yes			–
157	AVIN	Analog Input when using the internal ADC	Analog Input	YES			–
158	IBIAS	Input bias current	Analog Input	Yes			–
159	ADCVDD	Analog VDD supply	Analog Input	Yes			–
160	ADCGVDD	Guard VDD Supply	Analog Input	Yes			–

Table 6.7 Signal Summary List (Cont.)

Pin	Pin Name	Description	Buffer Type	5-Volt Compatible	Drive (mA)	Type	Active
Main Output							
63	DVOUT	SD0 Data Valid Out	LVTTL Output	Yes	4	3-state	–
62	DVOUT_LP	SD1 Data Valid Out	LVTTL Output	Yes	4	3-state	–
61	STARTOUT	First Soft Decision Mark	LVTTL Output	Yes	4	3-state	–
56–8, 60	SD0[3:0]	SD0 Bus	LVTTL Output	Yes	4	3-state	–
51–3, 55	SD1[3:0]	SD1 Bus	LVTTL Output	Yes	4	3-state	–
PWM Output							
42	VCXOUT	VCXOUT Timing Loop	LVTTL Output	Yes	4	Open Drain	–
122	AFCOUT	Output to the Tuner	LVTTL Output	Yes	4	Open Drain	–
150	AGCOUT	Output to the AGC	LVTTL Output	Yes	6	Open Drain	–
Mux In Pins							
5, 6, 8–12, 14–18, 21–24, 26	MUXIN[16:0]	Input Mux. Combined with DIGADCIN to form 27 input bits	LVTTL Input	Yes		Pull-Down	–
50	CLKMUXIN	Clock output use to Generate MUXIN bus	LVTTL Output	Yes	4		–

Table 6.7 Signal Summary List (Cont.)

Pin	Pin Name	Description	Buffer Type	5-Volt Compatible	Drive (mA)	Type	Active
Mux Out							
64, 66–69, 71–74, 76–79, 82–85, 87–90, 92–97,	MUXOUT[26:0]	Output Mux: Mainly for test issues	LVTTTL Output	Yes	4	3-state	–
3 Wires Buffer							
37–39	XCTR_OUT[2:0]	Pins used to control the Tuner	LVTTTL Output	Yes	4	3-state	–
2–4	XCTR_IN[2:0]	Pins used to retrieve informations from Tuner	LVTTTL Input	Yes			–
JTAG: Test Access Port (TAP)							
28	TCK	JTAG Tap Clock	LVTTTL Input	Yes		Pull-Up	–
29	TMS	JTAG Tap Test Mode Select	LVTTTL Input	Yes		Pull-Up	–
30	TDI	JTAG Tap Test Data Input	LVTTTL Input	Yes		Pull-Up	–
33	TDO	JTAG Tap Test Data Output	LVTTTL Output	Yes	4	3-state	–
27	TRESETN	JTAG Tap Reset	LVTTTL Input	Yes		Pull-Up	Low
Test PLL; Scan Mode; Bist Mode							
46	TEST0	Test Mode Selection	LVTTTL Input	Yes			–
47	TEST1	Test Mode Selection	LVTTTL Input	Yes			–

Table 6.7 Signal Summary List (Cont.)

Pin	Pin Name	Description	Buffer Type	5-Volt Compatible	Drive (mA)	Type	Active
ASIC Specific Pins							
45	TTN	Control tn pins of all bidirectional and 3-state outputs	LVTTL Input	Yes			Low
140	TIDDTN	Control power down PLL, oscillator and disable pull up/pull down	LVTTL Input	Yes			High
147	PROCQ	Dedicated output of Procmon	LVTTL Output	Yes			–
Internal PLL Pins							
103	PLLVSS	PLL ground	Analog Input	Yes			–
100	PLLVDD	PLL power	Analog Input	Yes			–
102	PLLLP2	VCO control voltage pin, connection to external loop filter	Analog Bidir	Yes			–
101	PLLAGND	PLL analog ground	Analog Output	Yes			–
Tester Pins							
145	PLLTSTCLK	open pll loop	LVTTL Input	Yes			–
146	PLLTSTSEL	replace pll clk output and feedback loop	LVTTL Input	Yes			High

1. A0 is also used as the I²C Serial Clock. Therefore Pin A0 is a Schmitt Buffer.
2. D0 is also used as the I²C Serial Data. Therefore, Pin D0 is a Bidirectional Schmitt Buffer.

6.4 Pinouts

The following subsections provide a numerical and alphabetic listing of the L64780 pins, as well as a pinout package drawing showing the location of the pins.

6.4.1 Pin List

[Table 6.8](#) numerically lists the L64780 pins and their associated signals.

Table 6.8 Pin List by Number

Signal	Pin	Signal	Pin	Signal	Pin	Signal	Pin
VDD	1	VSS	43	MUXOUT10	85	A2	127
XCTR_IN0	2	VSS2	44	VSS	86	A1	128
XCTR_IN1	3	TTN	45	MUXOUT9	87	A0	129
XCTR_IN2	4	TEST0	46	MUXOUT8	88	DIGIN_0	130
MUXIN0	5	TEST1	47	MUXOUT7	89	DIGIN_1	131
MUXIN1	6	VDD	48	MUXOUT6	90	VDD	132
VSS2	7	VDD	49	VDD	91	DIGIN_2	133
MUXIN2	8	CLKMUXIN	50	MUXOUT5	92	DIGIN_3	134
MUXIN3	9	SD1_3	51	MUXOUT4	93	DIGIN_4	135
MUXIN4	10	SD1_2	52	MUXOUT3	94	VSS	136
MUXIN5	11	SD1_1	53	MUXOUT2	95	VDD	137
MUXIN6	12	VSS	54	MUXOUT1	96	DIGIN_5	138
VDD	13	SD1_0	55	MUXOUT0	97	DIGIN_6	139
MUXIN7	14	SD0_3	56	VSS	98	TIDDTN	140
MUXIN8	15	SD0_2	57	CLK18	99	VSS2	141
MUXIN9	16	SD0_1	58	PLLVD	100	DIGIN_7	142
MUXIN10	17	VDD	59	PLLAGND	101	DIGIN_8	143
MUXIN11	18	SD0_0	60	PLLLP2	102	DIGIN_9	144
VSS2	19	STARTOUT	61	PLLVS	103	PLLTSTCLK	145
RESET	20	DVOUT_LP	62	VSS2	104	PLLTSTSEL	146
MUXIN12	21	DVOUT	63	P_S	105	PROCQ	147
MUXIN13	22	MUXOUT26	64	ASn	106	VDD	148
MUXIN14	23	VSS	65	CSn	107	VDD	149
MUXIN15	24	MUXOUT25	66	READ	108	AGCOUT	150
VDD	25	MUXOUT24	67	D_7	109	VSS	151
MUXIN16	26	MUXOUT23	68	VDD	110	ADCPD	152
TRESETN	27	MUXOUT22	69	VDD	111	ADCGVSS	153
TCK	28	VDD	70	D_6	112	ADCVSS	154
TMS	29	MUXOUT21	71	D_5	113	ADCVREFP	155
TDI	30	MUXOUT20	72	D_4	114	ADCVREFN	156
VSS2	31	MUXOUT19	73	D_3	115	AVIN	157
VSS	32	MUXOUT18	74	D_2	116	IBIAS	158
TDO	33	VSS	75	D_1	117	ADCVDD	159
CLKOUT54	34	MUXOUT17	76	D_0	118	ADCGVDD	160
DTACKn	35	MUXOUT16	77	VSS	119		
INTn	36	MUXOUT15	78	VSS2	120		
XCTR_OUT0	37	MUXOUT14	79	VSS	121		
XCTR_OUT1	38	VDD	80	AFCOUT	122		
XCTR_OUT2	39	VDD	81	VDD	123		
VDD	40	MUXOUT13	82	VSS2	124		
VDD	41	MUXOUT12	83	A_4	125		
VCXOUT	42	MUXOUT11	84	A_3	126		

Table 6.9 alphabetically lists the L64780 signals and their associated pins.

Table 6.9 Pin List by Name

Signal	Pin	Signal	Pin	Signal	Pin	Signal	Pin
A0	129	INTn	36	MUXOUT24	67	VDD	137
A1	128	MUXIN0	5	MUXOUT25	66	VDD	149
A2	127	MUXIN1	6	MUXOUT26	64	VDD	1
A3	126	MUXIN2	8	PLLAGND	101	VDD	13
A4	125	MUXIN3	9	PLLLP2	102	VDD	25
ADCGVDD	160	MUXIN4	10	PLLTSTCLK	145	VDD	48
ADCGVSS	153	MUXIN5	11	PLLTSTSEL	146	VDD	110
ADCPD	152	MUXIN6	12	PLLVDD	100	VDD	132
ADCVDD	159	MUXIN7	14	PLLVSS	103	VDD	148
ADCVREFN	156	MUXIN8	15	PROCQ	147	VSS	32
ADCVREFP	155	MUXIN9	16	READ	108	VSS	43
ADCVSS	154	MUXIN10	17	RESET	20	VSS	54
AFCOUT	122	MUXIN11	18	P_S	105	VSS	65
AGCOUT	150	MUXIN12	21	SD0_0	60	VSS	75
ASn	106	MUXIN13	22	SD0_1	58	VSS	86
AVIN	157	MUXIN14	23	SD0_2	57	VSS	98
CLK18	99	MUXIN15	24	SD0_3	56	VSS	119
CLKMUXIN	50	MUXIN16	26	SD1_2	52	VSS	121
CLKOUT54	34	MUXOUT0	97	SD1_0	55	VSS	136
CSn	107	MUXOUT1	96	SD1_1	53	VSS	151
D0	118	MUXOUT2	95	SD1_3	51	VSS2	7
D1	117	MUXOUT3	94	STARTOUT	61	VSS2	19
D2	116	MUXOUT4	93	TCK	28	VSS2	31
D3	115	MUXOUT5	92	TDI	30	VSS2	44
D4	114	MUXOUT6	90	TDO	33	VSS2	104
D5	113	MUXOUT7	89	TEST0	46	VSS2	120
D6	112	MUXOUT8	88	TEST1	47	VSS2	124
D7	109	MUXOUT9	87	TIDDTN	140	VSS2	141
DIGIN0	130	MUXOUT10	85	TMS	29	XCTR_IN0	2
DIGIN1	131	MUXOUT11	84	TRESETN	27	XCTR_IN1	3
DIGIN2	133	MUXOUT12	83	TTN	45	XCTR_IN2	4
DIGIN3	134	MUXOUT13	82	VCXOUT	42	XCTR_OUT0	37
DIGIN4	135	MUXOUT14	79	VDD	40	XCTR_OUT1	38
DIGIN5	138	MUXOUT15	78	VDD	41	XCTR_OUT2	39
DIGIN6	139	MUXOUT16	77	VDD	49		
DIGIN7	142	MUXOUT17	76	VDD	59		
DIGIN8	143	MUXOUT18	74	VDD	70		
DIGIN9	144	MUXOUT19	73	VDD	80		
DTACKn	35	MUXOUT20	72	VDD	81		
DVOUT	63	MUXOUT21	71	VDD	91		
DVOUT_LP	62	MUXOUT22	69	VDD	111		
IBIAS	158	MUXOUT23	68	VDD	123		

6.4.2 Pin Layout

Figure 6.4 illustrates the L64780 package pin layout.

Figure 6.4 Package Pin Layout

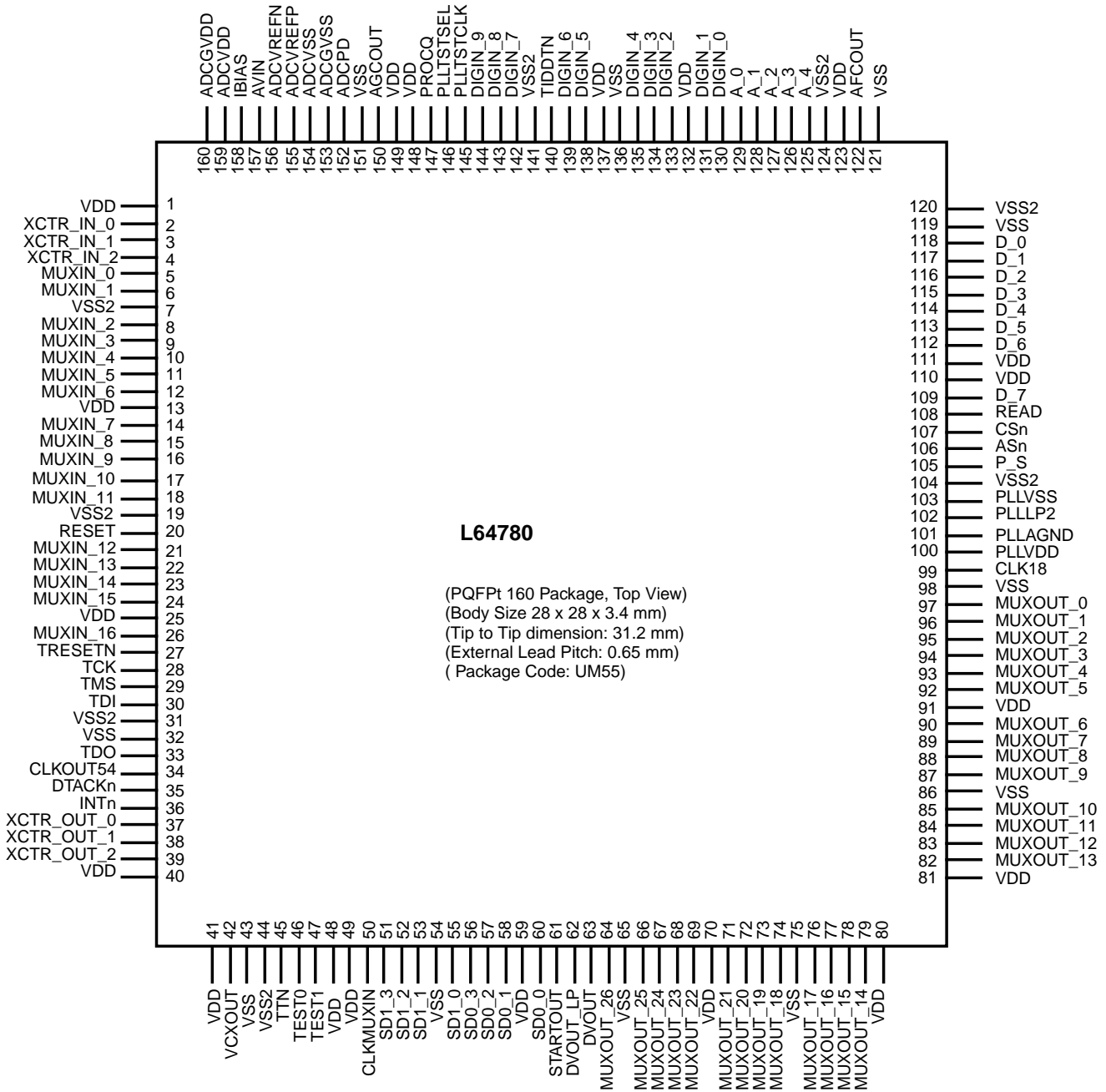

6.5 Mechanical Drawing

Figure 6.5 shows the mechanical drawing for the L64780 160-pin PQFP.

Figure 6.5 160 PQFP Mechanical Drawing: Top and Side Views

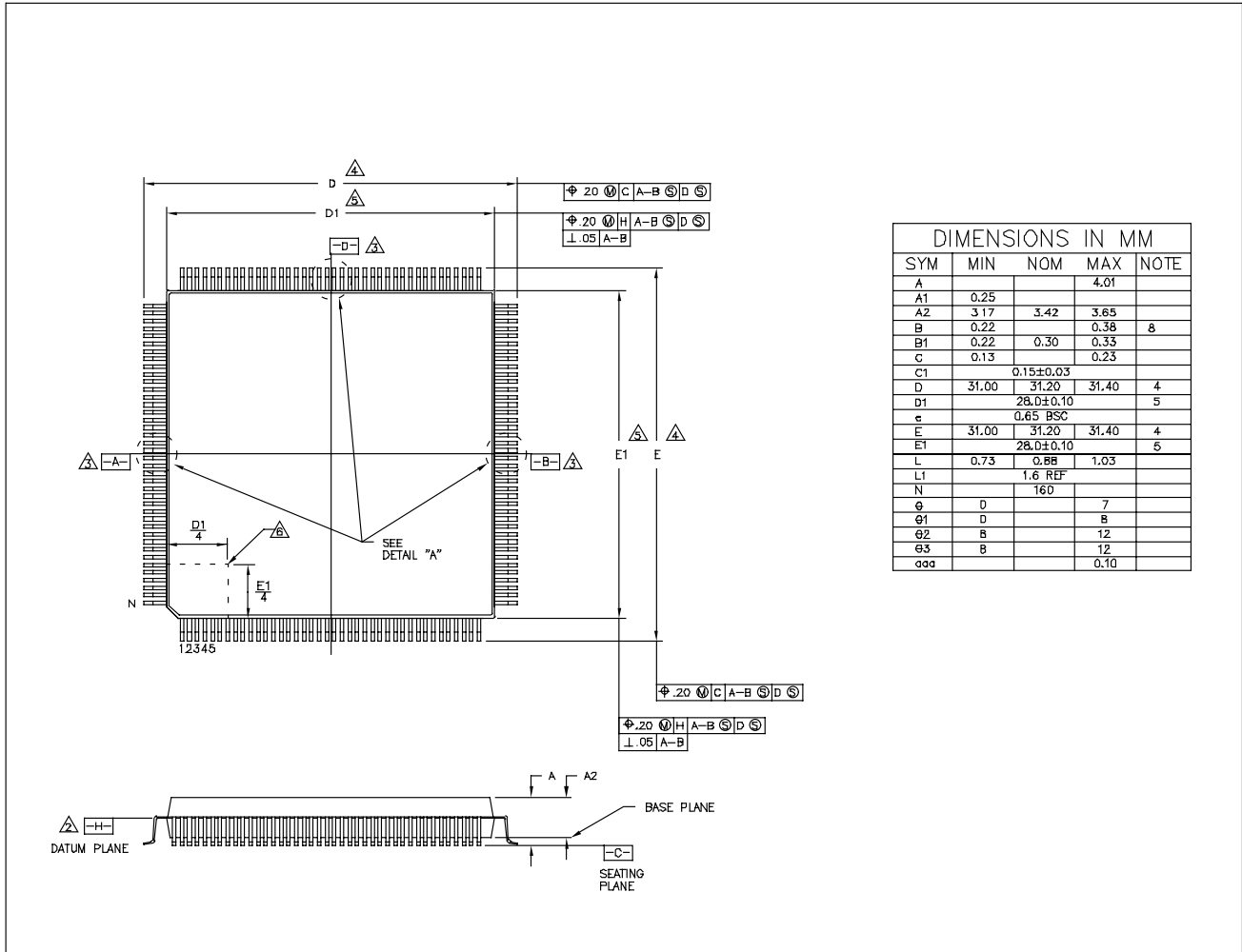

Important: This drawing may not be the latest version. For board layout and manufacturing, obtain the most recent engineering drawings from your LSI Logic marketing representative by requesting the outline drawing for package code UM55.

Figure 6.6 160 PQFP Mechanical Drawing: Detail

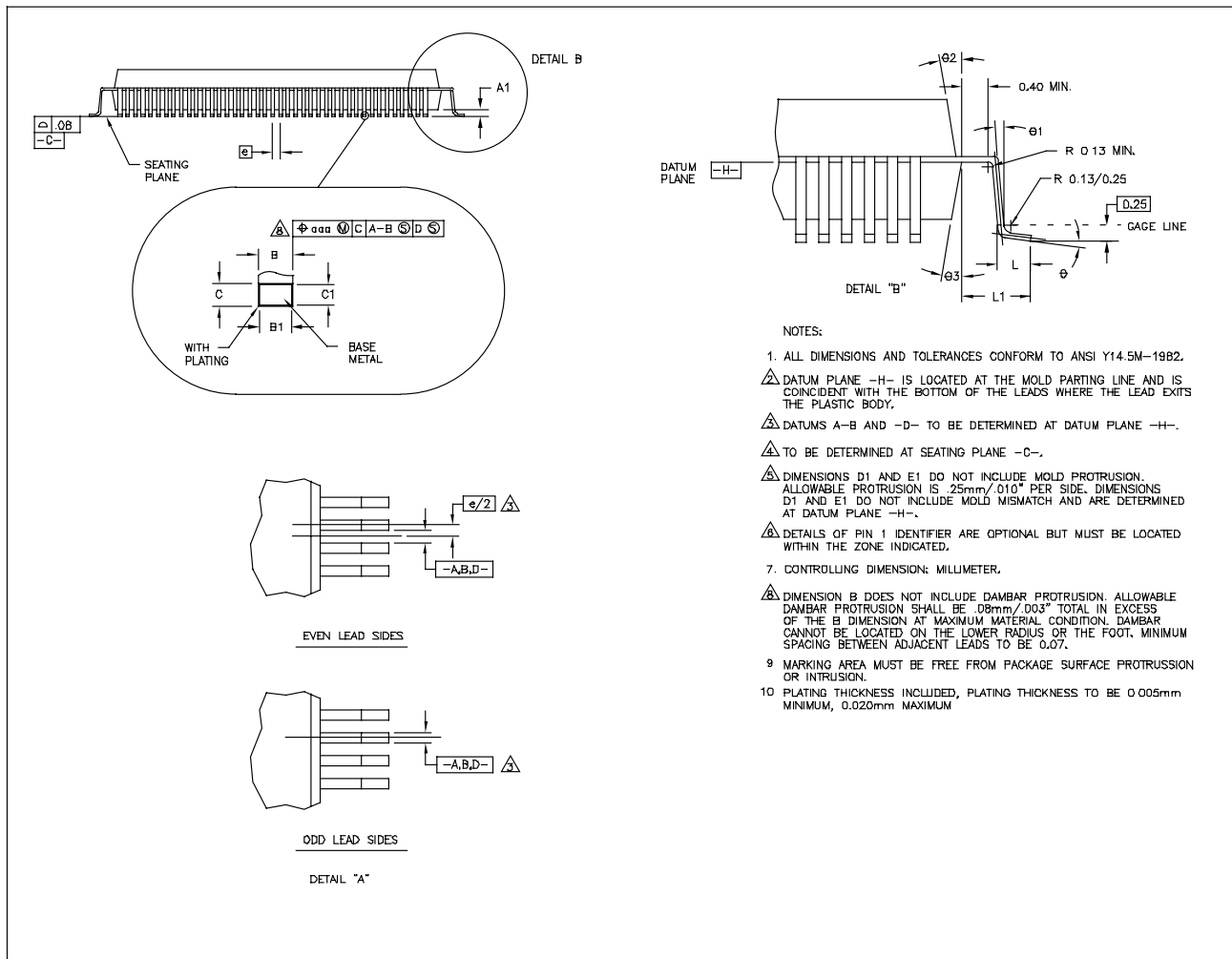

Important: This drawing may not be the latest version. For board layout and manufacturing, obtain the most recent engineering drawings from your LSI Logic marketing representative by requesting the outline drawing for package code UM55.

Appendix A

Programming the L64780 Using The Serial Bus Interface

This appendix discusses how to program the L64780 internal registers and data tables using the serial bus protocol. This appendix is intended primarily for system programmers who are developing software drivers using the serial bus.

It consists of the following sections:

- [Section A.1, “Serial Bus Protocol Overview,” page A-2](#)
- [Section A.2, “Programming the Slave Address Using the Serial Bus,” page A-3](#)

A.1 Serial Bus Protocol Overview

The multimaster Serial bus interface has two one-bit lines: A0 (Serial Clock), and D0 (Serial Data). These are connected to the bus (see [Figure A.1](#)). External pullup resistors hold the bus at a logic 1 when it is not in operation. See the Serial Bus protocol documentation for a detailed explanation and electrical characteristics. D[7:1] are used to set the serial bus slave address. When using the serial bus, D[7:1] must be hardwired to set the appropriate device slave address.

Select the serial bus mode on the L64780 by asserting P_S.

Features of the serial bus protocol include:

- Two one-bit lines: A0 and D0.
- D0: Serial Data.
- A0: serial clock (maximum frequency = 400 kHz).
- A0 and D0 have external pull-up resistors (the bus is normally HIGH).
- The Master always generates the clock, A0, and cycle start/stop conditions.

[Figure A.1](#) provides an overview illustration of the serial bus.

Figure A.1 Serial Bus Overview

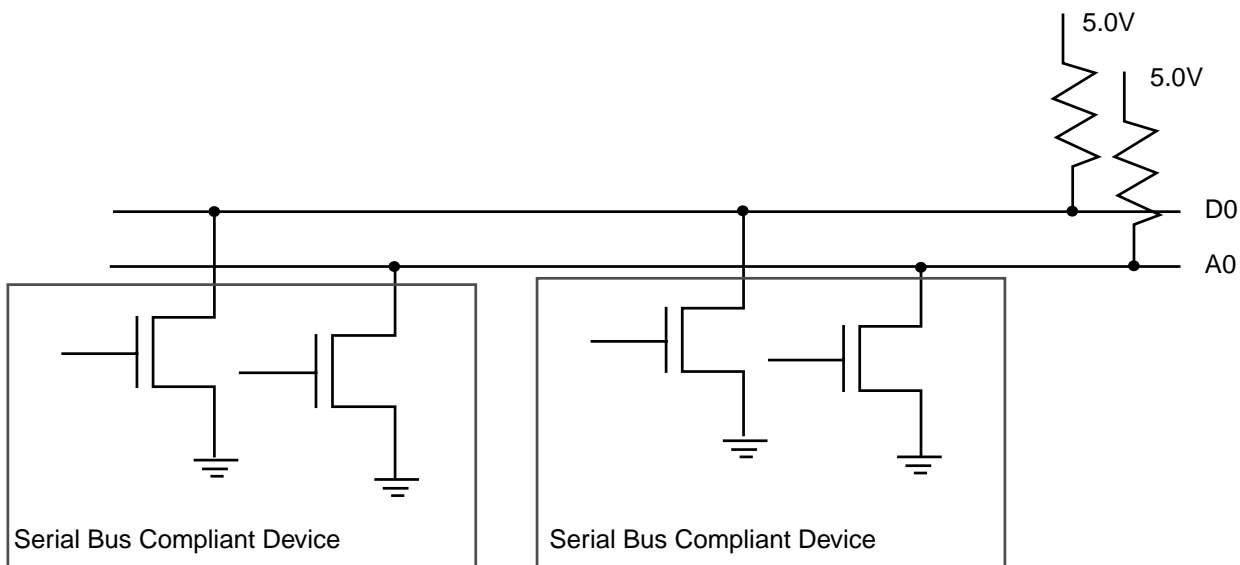

A.2 Programming the Slave Address Using the Serial Bus

A general call (Master issues a start condition followed by eight zeroes) is used to address every device on the serial bus. Any device that requires information to be supplied through this general call must acknowledge the cycle.

Figure A.2 General Call Address

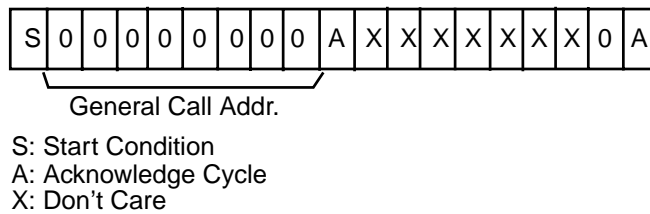

A.2.1 Write Cycle Using the Serial Bus

The following steps describe a write cycle using the serial bus.

1. The cycle is started by the Master issuing a start condition.
2. The 7-bit slave address is transmitted.
3. The R/W bit is reset to 0 and transmitted, indicating a write cycle.
4. The addressed Slave acknowledges the reception of the slave address by driving SDA LOW in the ACK cycle.
5. The Master sends the 8-bit address.
6. The addressed Slave acknowledges the reception of the address by driving SDA LOW in the ACK cycle.
7. The Master sends the 8-bit data.
8. The addressed Slave acknowledges the reception of the data by driving SDA LOW in the ACK cycle.
9. The Master terminates the cycle by issuing a stop condition.

A.2.2 Read Cycle Using the Serial Bus

1. The cycle is started with the start condition.
2. The 7-bit slave address is transmitted.
3. The R/W bit is reset to 0 and transmitted, indicating a write cycle.
4. The addressed Slave acknowledges the reception of the slave address by driving SDA LOW in the ACK cycle.
5. The Master sends the 8-bit address.
6. The addressed Slave acknowledges the reception of the address by driving SDA LOW in the ACK cycle.
7. The Master issues another start condition.
8. The 7-bit slave address is transmitted.
9. The R/W bit is set to 1 bit and transmitted, indicating a read cycle.
10. The addressed Slave acknowledges the reception of the slave address by driving SDA LOW in the ACK cycle.
11. The slave starts transmitting the data.
12. The Master must acknowledge receipt of the data by driving SDA LOW during the ACK cycle.
13. The Master terminates the cycle by issuing a stop condition.

Customer Feedback

We would appreciate your feedback on this document. Please copy the following page, add your comments, and fax it to us at the number shown.

If appropriate, please also fax copies of any marked-up pages from this document.

Important: Please include your name, phone number, fax number, and company address so that we may contact you directly for clarification or additional information.

Thank you for your help in improving the quality of our documents.

Reader's Comments

Fax your comments to: LSI Logic Corporation
Technical Publications
M/S E-198
Fax: 408.433.4333

Please tell us how you rate this document: *L64780 DVB-T COFDM Demodulator*. Place a check mark in the appropriate blank for each category.

	Excellent	Good	Average	Fair	Poor
Completeness of information	_____	_____	_____	_____	_____
Clarity of information	_____	_____	_____	_____	_____
Ease of finding information	_____	_____	_____	_____	_____
Technical content	_____	_____	_____	_____	_____
Usefulness of examples and illustrations	_____	_____	_____	_____	_____
Overall manual	_____	_____	_____	_____	_____

What could we do to improve this document?

If you found errors in this document, please specify the error and page number. If appropriate, please fax a marked-up copy of the page(s).

Please complete the information below so that we may contact you directly for clarification or additional information.

Name _____ Date _____
Telephone _____ Fax _____
Title _____
Department _____ Mail Stop _____
Company Name _____
Street _____
City, State, Zip _____

Customer Feedback

U.S. Distributors by State

A. E. Avnet Electronics
<http://www.hh.avnet.com>
B. M. Bell Microproducts,
Inc. (for HAB's)
<http://www.bellmicro.com>
I. E. Insight Electronics
<http://www.insight-electron-ics.com>
W. E. Wyle Electronics
<http://www.wyle.com>

Alabama

Daphne
I. E. Tel: 334.626.6190
Huntsville
A. E. Tel: 256.837.8700
I. E. Tel: 256.830.1222
W. E. Tel: 800.964.9953

Alaska

A. E. Tel: 800.332.8638

Arkansas

W. E. Tel: 972.235.9953

Arizona

Phoenix
A. E. Tel: 480.736.7000
B. M. Tel: 602.267.9551
W. E. Tel: 800.528.4040
Tempe
I. E. Tel: 480.829.1800
Tucson
A. E. Tel: 520.742.0515

California

Agoura Hills
B. M. Tel: 818.865.0266
Irvine
A. E. Tel: 949.789.4100
B. M. Tel: 949.470.2900
I. E. Tel: 949.727.3291
W. E. Tel: 800.626.9953
Los Angeles
A. E. Tel: 818.594.0404
W. E. Tel: 800.288.9953
Sacramento
A. E. Tel: 916.632.4500
W. E. Tel: 800.627.9953
San Diego
A. E. Tel: 858.385.7500
B. M. Tel: 858.597.3010
I. E. Tel: 800.677.6011
W. E. Tel: 800.829.9953
San Jose
A. E. Tel: 408.435.3500
B. M. Tel: 408.436.0881
I. E. Tel: 408.952.7000
Santa Clara
W. E. Tel: 800.866.9953
Woodland Hills
A. E. Tel: 818.594.0404
Westlake Village
I. E. Tel: 818.707.2101

Colorado

Denver
A. E. Tel: 303.790.1662
B. M. Tel: 303.846.3065
W. E. Tel: 800.933.9953
Englewood
I. E. Tel: 303.649.1800

Connecticut

Cheshire
A. E. Tel: 203.271.5700
I. E. Tel: 203.272.5843
Wallingford
W. E. Tel: 800.605.9953

Delaware

North/South
A. E. Tel: 800.526.4812
Tel: 800.638.5988
B. M. Tel: 302.328.8968
W. E. Tel: 856.439.9110

Florida

Altamonte Springs
B. M. Tel: 407.682.1199
I. E. Tel: 407.834.6310
Boca Raton
I. E. Tel: 561.997.2540
Clearwater
I. E. Tel: 727.524.8850
Fort Lauderdale
A. E. Tel: 954.484.5482
W. E. Tel: 800.568.9953
Miami
B. M. Tel: 305.477.6406
Orlando
A. E. Tel: 407.657.3300
W. E. Tel: 407.740.7450
Tampa
W. E. Tel: 800.395.9953
St. Petersburg
A. E. Tel: 727.507.5000

Georgia

Atlanta
A. E. Tel: 770.623.4400
B. M. Tel: 770.980.4922
W. E. Tel: 800.876.9953
Duluth
I. E. Tel: 678.584.0812

Hawaii

A. E. Tel: 800.851.2282

Idaho

A. E. Tel: 801.365.3800
W. E. Tel: 801.974.9953

Illinois

North/South
A. E. Tel: 847.797.7300
Tel: 314.291.5350
Chicago
B. M. Tel: 847.413.8530
W. E. Tel: 800.853.9953
Schaumburg
I. E. Tel: 847.885.9700

Indiana

Fort Wayne
I. E. Tel: 219.436.4250
W. E. Tel: 888.358.9953
Indianapolis
A. E. Tel: 317.575.3500

Iowa

W. E. Tel: 612.853.2280
Cedar Rapids
A. E. Tel: 319.393.0033

Kansas

W. E. Tel: 303.457.9953
Kansas City
A. E. Tel: 913.663.7900
Lenexa
I. E. Tel: 913.492.0408

Kentucky

W. E. Tel: 937.436.9953
Central/Northern/ Western
A. E. Tel: 800.984.9503
Tel: 800.767.0329
Tel: 800.829.0146

Louisiana

W. E. Tel: 713.854.9953
North/South
A. E. Tel: 800.231.0253
Tel: 800.231.5575

Maine

A. E. Tel: 800.272.9255
W. E. Tel: 781.271.9953

Maryland

Baltimore
A. E. Tel: 410.720.3400
W. E. Tel: 800.863.9953
Columbia
B. M. Tel: 800.673.7461
I. E. Tel: 410.381.3131

Massachusetts

Boston
A. E. Tel: 978.532.9808
W. E. Tel: 800.444.9953
Burlington
I. E. Tel: 781.270.9400
Marlborough
B. M. Tel: 508.480.9099
Woburn
B. M. Tel: 781.933.9010

Michigan

Brighton
I. E. Tel: 810.229.7710
Detroit
A. E. Tel: 734.416.5800
W. E. Tel: 888.318.9953

Minnesota

Champlin
B. M. Tel: 800.557.2566
Eden Prairie
B. M. Tel: 800.255.1469
Minneapolis
A. E. Tel: 612.346.3000
W. E. Tel: 800.860.9953
St. Louis Park
I. E. Tel: 612.525.9999

Mississippi

A. E. Tel: 800.633.2918
W. E. Tel: 256.830.1119

Missouri

W. E. Tel: 630.620.0969
St. Louis
A. E. Tel: 314.291.5350
I. E. Tel: 314.872.2182

Montana

A. E. Tel: 800.526.1741
W. E. Tel: 801.974.9953

Nebraska

A. E. Tel: 800.332.4375
W. E. Tel: 303.457.9953

Nevada

Las Vegas
A. E. Tel: 800.528.8471
W. E. Tel: 702.765.7117

New Hampshire

A. E. Tel: 800.272.9255
W. E. Tel: 781.271.9953

New Jersey

North/South
A. E. Tel: 201.515.1641
Tel: 609.222.6400
Mt. Laurel
I. E. Tel: 609.222.9566
Pine Brook
W. E. Tel: 800.862.9953
Parsippany
I. E. Tel: 973.299.4425
Wayne
W. E. Tel: 973.237.9010

New Mexico

W. E. Tel: 480.804.7000
Albuquerque
A. E. Tel: 505.293.5119

U.S. Distributors by State (Continued)

New York

Hauppauge
I. E. Tel: 516.761.0960
Long Island
A. E. Tel: 516.434.7400
W. E. Tel: 800.861.9953
Rochester
A. E. Tel: 716.475.9130
I. E. Tel: 716.242.7790
W. E. Tel: 800.319.9953
Smithtown
B. M. Tel: 800.543.2008
Syracuse
A. E. Tel: 315.449.4927

North Carolina

Raleigh
A. E. Tel: 919.859.9159
I. E. Tel: 919.873.9922
W. E. Tel: 800.560.9953

North Dakota

A. E. Tel: 800.829.0116
W. E. Tel: 612.853.2280

Ohio

Cleveland
A. E. Tel: 216.498.1100
W. E. Tel: 800.763.9953
Dayton
A. E. Tel: 614.888.3313
I. E. Tel: 937.253.7501
W. E. Tel: 800.575.9953
Strongsville
B. M. Tel: 440.238.0404
Valley View
I. E. Tel: 216.520.4333

Oklahoma

W. E. Tel: 972.235.9953
Tulsa
A. E. Tel: 918.459.6000
I. E. Tel: 918.665.4664

Oregon

Beaverton
B. M. Tel: 503.524.0787
I. E. Tel: 503.644.3300
Portland
A. E. Tel: 503.526.6200
W. E. Tel: 800.879.9953

Pennsylvania

Mercer
I. E. Tel: 412.662.2707
Pittsburgh
A. E. Tel: 412.281.4150
W. E. Tel: 440.248.9996
Philadelphia
A. E. Tel: 800.526.4812
B. M. Tel: 215.741.4080
W. E. Tel: 800.871.9953

Rhode Island

A. E. 800.272.9255
W. E. Tel: 781.271.9953

South Carolina

A. E. Tel: 919.872.0712
W. E. Tel: 919.469.1502

South Dakota

A. E. Tel: 800.829.0116
W. E. Tel: 612.853.2280

Tennessee

W. E. Tel: 256.830.1119
East/West
A. E. Tel: 800.241.8182
Tel: 800.633.2918

Texas

Austin
A. E. Tel: 512.219.3700
B. M. Tel: 512.258.0725
I. E. Tel: 512.719.3090
W. E. Tel: 800.365.9953
Dallas
A. E. Tel: 214.553.4300
B. M. Tel: 972.783.4191
W. E. Tel: 800.955.9953
El Paso
A. E. Tel: 800.526.9238
Houston
A. E. Tel: 713.781.6100
B. M. Tel: 713.917.0663
W. E. Tel: 800.888.9953
Richardson
I. E. Tel: 972.783.0800
Rio Grande Valley
A. E. Tel: 210.412.2047
Stafford
I. E. Tel: 281.277.8200

Utah

Centerville
B. M. Tel: 801.295.3900
Murray
I. E. Tel: 801.288.9001
Salt Lake City
A. E. Tel: 801.365.3800
W. E. Tel: 800.477.9953

Vermont

A. E. Tel: 800.272.9255
W. E. Tel: 716.334.5970

Virginia

A. E. Tel: 800.638.5988
W. E. Tel: 301.604.8488

Washington

Kirkland
I. E. Tel: 425.820.8100
Seattle
A. E. Tel: 425.882.7000
W. E. Tel: 800.248.9953

West Virginia

A. E. Tel: 800.638.5988

Wisconsin

Milwaukee
A. E. Tel: 414.513.1500
W. E. Tel: 800.867.9953
Wauwatosa
I. E. Tel: 414.258.5338

Wyoming

A. E. Tel: 800.332.9326
W. E. Tel: 801.974.9953

Sales Offices and Design Resource Centers

LSI Logic Corporation
Corporate Headquarters
Tel: 408.433.8000
Fax: 408.433.8989

NORTH AMERICA

California
Costa Mesa - Mint Technology
Tel: 949.752.6468
Fax: 949.752.6868

Irvine
◆ Tel: 949.809.4600
Fax: 949.809.4444

Pleasanton Design Center
Tel: 925.730.8800
Fax: 925.730.8700

San Diego
Tel: 858.467.6981
Fax: 858.496.0548

Silicon Valley
◆ Tel: 408.433.8000
Fax: 408.954.3353

Wireless Design Center
Tel: 858.350.5560
Fax: 858.350.0171

Colorado
Boulder
◆ Tel: 303.447.3800
Fax: 303.541.0641

Colorado Springs
Tel: 719.533.7000
Fax: 719.533.7020

Fort Collins
Tel: 970.223.5100
Fax: 970.206.5549

Florida
Boca Raton
Tel: 561.989.3236
Fax: 561.989.3237

Georgia
Alpharetta
Tel: 770.753.6146
Fax: 770.753.6147

Illinois
Oakbrook Terrace
Tel: 630.954.2234
Fax: 630.954.2235

Kentucky
Bowling Green
Tel: 270.793.0010
Fax: 270.793.0040

Maryland
Bethesda
Tel: 301.897.5800
Fax: 301.897.8389

Massachusetts
Waltham
◆ Tel: 781.890.0180
Fax: 781.890.6158

Burlington - Mint Technology
Tel: 781.685.3800
Fax: 781.685.3801

Minnesota
Minneapolis
◆ Tel: 612.921.8300
Fax: 612.921.8399

New Jersey
Red Bank
Tel: 732.933.2656
Fax: 732.933.2643

Cherry Hill - Mint Technology
Tel: 609.489.5530
Fax: 609.489.5531

New York
Fairport
Tel: 716.218.0020
Fax: 716.218.9010

North Carolina
Raleigh
Tel: 919.785.4520
Fax: 919.783.8909

Oregon
Beaverton
Tel: 503.645.0589
Fax: 503.645.6612

Texas
Austin
Tel: 512.388.7294
Fax: 512.388.4171

Plano
◆ Tel: 972.244.5000
Fax: 972.244.5001

Houston
Tel: 281.379.7800
Fax: 281.379.7818

Canada
Ontario
Ottawa
◆ Tel: 613.592.1263
Fax: 613.592.3253

INTERNATIONAL

France
Paris
LSI Logic S.A.
Immeuble Europa
◆ Tel: 33.1.34.63.13.13
Fax: 33.1.34.63.13.19

Germany
Munich
LSI Logic GmbH
◆ Tel: 49.89.4.58.33.0
Fax: 49.89.4.58.33.108

Stuttgart
Tel: 49.711.13.96.90
Fax: 49.711.86.61.428

Italy
Milano
LSI Logic S.P.A.
◆ Tel: 39.039.687371
Fax: 39.039.6057867

Japan
Tokyo
LSI Logic K.K.
◆ Tel: 81.3.5463.7821
Fax: 81.3.5463.7820

Osaka
◆ Tel: 81.6.947.5281
Fax: 81.6.947.5287

Korea
Seoul
LSI Logic Corporation of Korea Ltd
Tel: 82.2.528.3400
Fax: 82.2.528.2250

The Netherlands
Eindhoven
LSI Logic Europe Ltd
Tel: 31.40.265.3580
Fax: 31.40.296.2109

Singapore
Singapore
LSI Logic Pte Ltd
Tel: 65.334.9061
Fax: 65.334.4749

Tel: 65.835.5040
Fax: 65.732.5047

Sweden
Stockholm
LSI Logic AB
◆ Tel: 46.8.444.15.00
Fax: 46.8.750.66.47

Taiwan
Taipei
LSI Logic Asia, Inc.
Taiwan Branch
Tel: 886.2.2718.7828
Fax: 886.2.2718.8869

United Kingdom
Bracknell
LSI Logic Europe Ltd
◆ Tel: 44.1344.426544
Fax: 44.1344.481039

◆ Sales Offices with Design Resource Centers

International Distributors

Australia

New South Wales
Reptechnic Pty Ltd
◆ Tel: 612.9953.9844
Fax: 612.9953.9683

Belgium

Acal nv/sa
Tel: 32.2.7205983
Fax: 32.2.7251014

China

Beijing
LSI Logic International Services Inc.
Tel: 86.10.6804.2534
Fax: 86.10.6804.2521

France

Rungis Cedex
Azzurri Technology France
Tel: 33.1.41806310
Fax: 33.1.41730340

Germany

Haar
EBV Elektronik
Tel: 49.89.4600980
Fax: 49.89.46009840

Munich

Avnet Emg GmbH
Tel: 49.89.45110102
Fax: 49.89.42.27.75

Wuennenberg-Haaren

Peacock AG
Tel: 49.2957.79.1692
Fax: 49.2957.79.9341

Hong Kong

Hong Kong
AVT Industrial Ltd
Tel: 852.2428.0008
Fax: 852.2401.2105

EastEle

Tel: 852.2798.8860
Fax: 852.2305.0640

India

Bangalore
Spike Technologies India Private Ltd
◆ Tel: 91.80.664.5530
Fax: 91.80.664.9748

Israel

Tel Aviv
Eastronics Ltd
Tel: 972.3.6458777
Fax: 972.3.6458666

Japan

Tokyo
Global Electronics Corporation
Tel: 81.3.3260.1411
Fax: 81.3.3260.7100
Technical Center
Tel: 81.471.43.8200

Yokohama-City

Macnica Corporation
Tel: 81.45.939.6140
Fax: 81.45.939.6141

The Netherlands

Eindhoven
Acal Nederland b.v.
Tel: 31.40.2.502602
Fax: 31.40.2.510255

Switzerland

Brugg
LSI Logic Sulzer AG
Tel: 41.32.3743232
Fax: 41.32.3743233

Taiwan

Taipei
Avnet-Mercuries Corporation, Ltd
Tel: 886.2.2516.7303
Fax: 886.2.2505.7391

Lumax International Corporation, Ltd

Tel: 886.2.2788.3656
Fax: 886.2.2788.3568

Prospect Technology Corporation, Ltd

Tel: 886.2.2721.9533
Fax: 886.2.2773.3756

Serial Semiconductor Corporation, Ltd

Tel: 886.2.2579.5858
Fax: 886.2.2570.3123

United Kingdom

Maidenhead
Azzurri Technology Ltd
Tel: 44.1628.826826
Fax: 44.1628.829730

Swindon

EBV Elektronik
Tel: 44.1793.849933
Fax: 44.1793.859555

◆ Sales Offices with Design Resource Centers