



M.S.KENNEDY CORP.

**RAD HARD ULTRA LOW
DROPOUT POSITIVE ADJUSTABLE
LINEAR REGULATOR**

5824RH

4707 Dey Road Liverpool, N.Y. 13088

(315) 701-6751

FEATURES:

- Manufactured using  Space Qualified RH1573 Die
- Replaces IR OMR9604 and IRUH33PA13A
- Total Dose Tested to 450K RAD (Method 1019.7 Condition A)
- Ultra Low Dropout for Reduced Power Consumption
- External Shutdown Function
- Latching Overload Protection
- Optimized for 3.3V Input
- 1.265V to (VIN-0.4V) Output Voltage Range
- Output Current Limit
- Available in 2 Lead Form Options: Straight and Gullwing
- Contact MSK for MIL-PRF-38534 Qualification Status
- Available soon to DSCC SMD 5962F09208

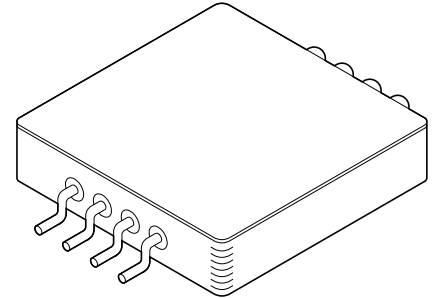

DESCRIPTION:

The MSK 5824RH is a rad hard adjustable linear regulator capable of delivering 3.0 amps of output current. Typical dropout is only 0.30 volts with a 3 amp load. An external shutdown function is ideal for power supply sequencing. This device also has internal latching overload protection. The MSK 5824RH is radiation hard and specifically designed for space/satellite applications. The device is packaged in a hermetically sealed space efficient 8 pin flatpack that is electrically isolated from the internal circuitry allowing for direct heat sinking.

EQUIVALENT SCHEMATIC

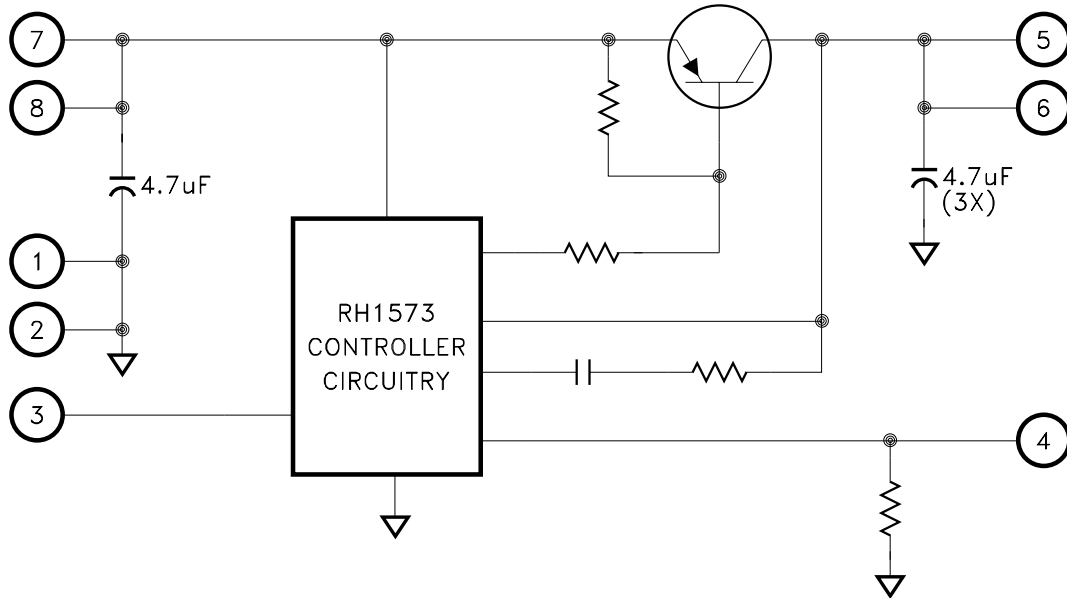

TYPICAL APPLICATIONS

- Satellite System Power Supplies
- Switching Power Supply Post Regulators
- Constant Voltage/Current Regulators
- Microprocessor Power Supplies

PIN-OUT INFORMATION

1 GND	8 VIN
2 GND	7 VIN
3 SHUTDOWN	6 VOUT
4 ADJUST	5 VOUT

 and the Linear Technology logo are registered trademarks and RH1573 is a copyright of Linear Technology Corporation

ABSOLUTE MAXIMUM RATINGS ^⑨

+ V _{IN}	Supply Voltage	+ 7V	T _{ST}	Storage Temperature Range	-65°C to + 150°C
I _{OUT}	Output Current ^⑦	3.5A	T _{LD}	Lead Temperature Range	300°C (10 Seconds)
T _C	Case Operating Temperature Range		P _D	Power Dissipation	See SOA Curve
	MSK5824K/H/E RH	-55°C to + 125°C	T _C	Junction Temperature	150°C
	MSK5824RH	-40°C to + 85°C			

ELECTRICAL SPECIFICATIONS

Parameter	Test Conditions ^① ^⑩	Group A Subgroup	MSK 5824 K/H/E RH			MSK 5824RH			Units
			Min.	Typ.	Max.	Min.	Typ.	Max.	
Reference Voltage		1,2,3	1.225	1.265	1.305	-	-	-	V
	Post 100KRAD(Si)	1	1.225	-	1.305	1.225	-	1.305	V
	Post 300KRAD(Si)	1	1.225	-	1.310	1.225	-	1.310	V
Line Regulation	2.97V ≤ V _{IN} ≤ 3.63V, I _O = 50mA	1	-0.25	-	+0.25	-0.25	-	+0.25	%/V
		2,3	-0.5	-	+0.5	-	-	-	%/V
Load Regulation	V _{IN} = 3.3V, 50mA ≤ I _{OUT} ≤ 3.0A	1	-1.0	-	1.0	-1.0	-	1.0	%/A
		2,3	-2.0	-	2.0	-	-	-	%/A
Input Voltage Range-Operating ^②	I _O = 3.0A	1,2,3	2.9	-	6.5	2.9	-	6.5	V
Dropout Voltage ^⑤	I _O = 3.0A, V _{OUT} = 2.5V	1,2,3	-	-	0.5	-	-	0.5	V
Current Limit ^⑦	V _{IN} = 3.3V, Overcurrent Latchup	1,2,3	3.0	-	-	3.0	-	-	A
Ripple Rejection ^②	F = 120Hz, I _O = 50mA	4	65	-	-	65	-	-	dB
		Post 300KRAD(Si)	4	40	-	-	40	-	-
Shutdown Source Current ^⑧	V _{SHDN} = 5.0V	-	-	200	-	-	200	-	µA
Shutdown Pin Threshold ^⑧	V _{IN} = 3.3V	1,2,3	1.0	-	1.6	1.0	-	1.6	V
Output Voltage at Shutdown	V _{IN} = 3.3V, I _O = 50mA V _{SHDN} = +3.3V	1,2,3	-0.1	-	+0.1	-0.1	-	+0.1	V
Thermal Resistance ^②	Junction to Case @ 125°C Output Device	-	-	5.0	6.5	-	5.0	6.5	°C/W

NOTES:

- ① Unless otherwise specified, V_{IN} = 3.3V, V_{SHUTDOWN} = 0V and I_{OUT} = 50mA. See figure 2 for typical test circuit.
- ② Guaranteed by design but not tested. Typical parameters are representative of actual device performance but are for reference only.
- ③ Industrial grade and "E" suffix devices shall be tested to subgroups 1 and 4 unless otherwise requested.
- ④ Military grade devices ("H" and "K" suffix) shall be 100% tested to subgroups 1,2,3 and 4.
- ⑤ Dropout limited by minimum value of V_{IN}.
- ⑥ Subgroup 1,4 TC = + 25°C
Subgroup 2 TC = + 125°C
Subgroup 3 TA = -55°C
- ⑦ Output current limit is dependent upon the values of V_{IN} and V_{OUT}. See Figure 1 and typical performance curves.
- ⑧ Refer to typical performance curves.
- ⑨ Continuous operation at or above absolute maximum ratings may adversely effect the device performance and/or life cycle.
- ⑩ Pre and post irradiation limits at 25°C, up to 300Krad TID, are identical unless otherwise specified.
- ⑪ Reference DSCC SMD 5962F09208 for electrical specification for devices purchased as such.

APPLICATION NOTES

PIN FUNCTIONS

V_{IN} - These pins provide power to all internal circuitry including bias, start-up, thermal limit and overcurrent latch. Input voltage range is 2.9V to 6.5V but the MSK 5824RH is optimized for 3.3V input. See MSK 5826RH for 5V input version.

GND - Internally connected to ground, these pins should be connected externally by the user to the circuit ground.

SHUTDOWN - There are two functions to the SHUTDOWN pin. It may be used to disable the output voltage or to reset a current latch condition. To activate the shutdown/reset functions the user must apply a voltage greater than 1.6V to the SHUTDOWN pin. The output voltage will turn on when the SHUTDOWN pin is pulled below the threshold voltage. If the SHUTDOWN pin is not used, it should be connected to ground. It should be noted that with the shutdown pin tied to ground, a current latch condition can only be reset by cycling power off, then on.

V_{OUT} - These are the output pins for the device.

ADJUST - This pin is used to set the output voltage. Connect a resistor between the adjust pin (4) and the output pins (5 and 6) to fix the output voltage at the desired value. Use the following equations to determine the nominal value of the adjust resistor (RADJ).

$$V_{OUT} = V_{REF} \times (1 + \text{RADJ}/1\text{K}\Omega)$$

$$\text{RADJ} = (V_{OUT}/V_{REF} - 1) \times 1\text{K}\Omega$$

OVERCURRENT LATCH

Overcurrent protection is provided by the MSK 5824RH series through the use of a timed latch off circuit. The internal latch timeout is triggered by an overcurrent condition. To allow for start up surge currents, the timeout is approximately TBDmS at 25° C. If the overcurrent condition remains at the end of the timeout cycle, the regulator will latch off until the latch is reset. To reset the latch, toggle the shutdown pin high then low or cycle V_{IN} off then back on. A thermal limit condition will trigger the latch with no time out delay.

INPUT POWER SUPPLY BYPASSING

The MSK 5824RH contains an internal 4.7μF tantalum input capacitor, type CWR19HB475CBB. The capacitor is rated for 15V maximum applied voltage and has been surge tested in accordance with condition B of MIL-PRF-55365. The system designer must ensure proper de-rating in accordance with their system requirements. To maximize transient response and minimize power supply transients it is recommended that a 100μF tantalum capacitor is connected between V_{IN} and ground. A 0.1μF ceramic capacitor should also be used for high frequency bypassing.

OUTPUT CAPACITOR SELECTION

The MSK 5824RH contains three internal 4.7μF tantalum output capacitors, type CWR19HB475KCBB. The capacitor are rated for 15V maximum applied voltage and have been surge tested in accordance with condition B of MIL-PRF-55365. The system designer must ensure proper de-rating in accordance with their system requirements. Output capacitors are required to maintain regulation and stability. A 220μF surface mount tantalum capacitor from the output to ground should suffice under most conditions. Ceramic output capacitors (0.1μF typical) should be placed directly across the load power connections as close to the load as possible. If the user finds that tighter voltage regulation is needed during output transients, more capacitance may be added. If more capacitance is added to the output, the bandwidth may suffer.

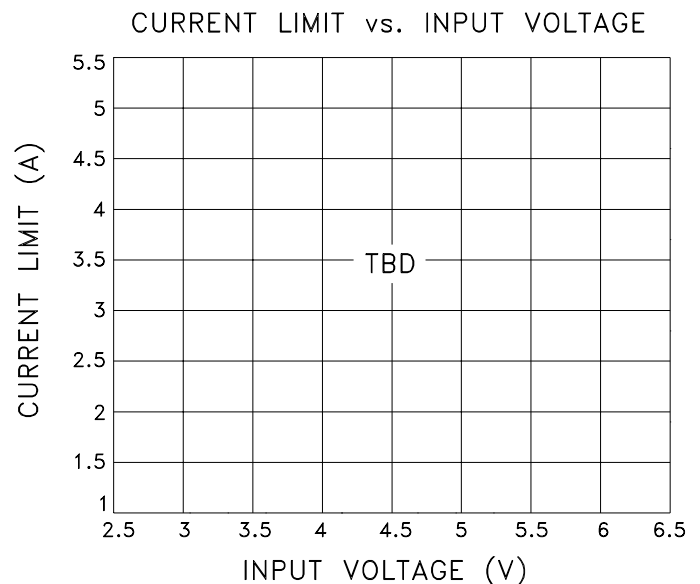

FIGURE 1

CURRENT LIMIT AND SOA

The MSK 5824RH current limit function is directly affected by the input and output voltages. Figure 1 illustrates the relationship between V_{IN} and I_{CL} for various output voltages. It is very important for the user to consult the SOA curve when using input voltages which result in current limit conditions beyond 3.5 Amps. When using input voltages which result in current limit above 3.5 Amps, the user must maintain output current within the SOA curve to avoid damage to the device. The current limit is adjusted internally for an input voltage of 3.3V.

APPLICATION NOTES CONT.

THERMAL LIMITING

The MSK 5824RH control circuitry has a thermal shutdown temperature of approximately 150°C. This thermal shutdown can be used as a protection feature, but for continuous operation, the junction temperature of the pass transistor must be maintained below 150°C. Proper heat sink selection is essential to maintain these conditions. Exceeding the thermal limit activates the latch feature of the MSK 5824RH. Toggle the shutdown pin high then low or cycle power to reset the latch. See shutdown pin description and overcurrent latch description for more information.

HEAT SINK SELECTION

To select a heat sink for the MSK 5824RH, the following formula for convective heat flow may be used.

Governing Equation:

$$T_J = P_D \times (R_{\theta JC} + R_{\theta CS} + R_{\theta SA}) + T_A$$

Where

- T_J = Junction Temperature
- P_D = Total Power Dissipation
- $R_{\theta JC}$ = Junction to Case Thermal Resistance
- $R_{\theta CS}$ = Case to Heat Sink Thermal Resistance
- $R_{\theta SA}$ = Heat Sink to Ambient Thermal Resistance
- T_A = Ambient Temperature

$$\text{Power Dissipation} = (V_{IN} - V_{OUT}) \times I_{OUT}$$

Next, the user must select a maximum junction temperature. The absolute maximum allowable junction temperature is 150°C. The equation may now be rearranged to solve for the required heat sink to ambient thermal resistance ($R_{\theta SA}$).

Example:

An MSK 5824RH is connected for $V_{IN} = +3.3V$ and $V_{OUT} = +2.5V$. I_{OUT} is a continuous 3A DC level. The ambient temperature is +25°C. The maximum desired junction temperature is +125°C.

$R_{\theta JC} = 6.5^\circ C/W$ and $R_{\theta CS} = 0.15^\circ C/W$ for most thermal greases

$$\begin{aligned} \text{Power Dissipation} &= (3.3V - 2.5V) \times (3A) \\ &= 2.4 \text{ Watts} \end{aligned}$$

Solve for $R_{\theta SA}$:

$$\begin{aligned} R_{\theta SA} &= \left[\frac{125^\circ C - 25^\circ C}{2.4W} \right] - 6.5^\circ C/W - 0.15^\circ C/W \\ &= 35.0^\circ C/W \end{aligned}$$

In this example, a heat sink with a thermal resistance of no more than 35.0°C/W must be used to maintain a junction temperature of no more than 125°C.

TYPICAL APPLICATIONS CIRCUIT

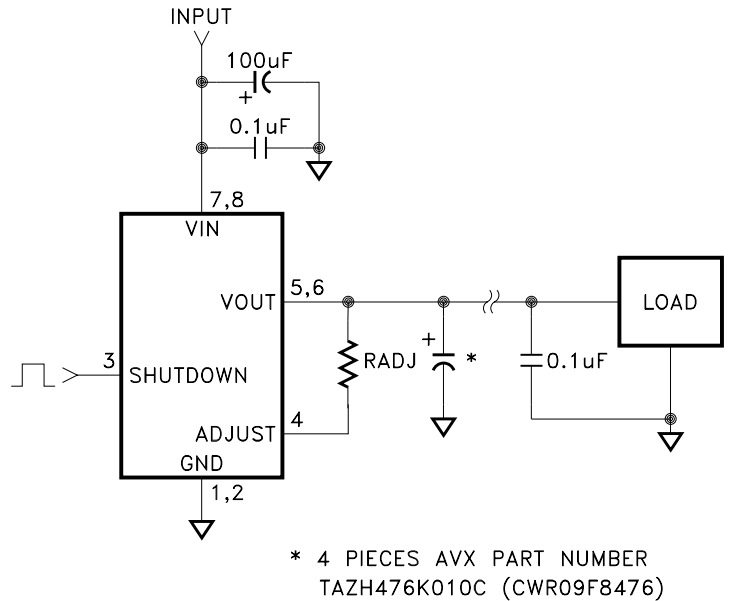

FIGURE 2

TOTAL DOSE RADIATION TEST PERFORMANCE

Radiation performance curves for TID testing have been generated for all radiation testing performed by MSK Kennedy. These curves show performance trends throughout the TID test process and are located in the MSK 5826RH radiation test report. The complete radiation test report is available in the RAD HARD PRODUCTS section on the MSK website.

<http://www.mskennedy.com/store.asp?pid=9951&catid=19680>

TYPICAL PERFORMANCE CURVES

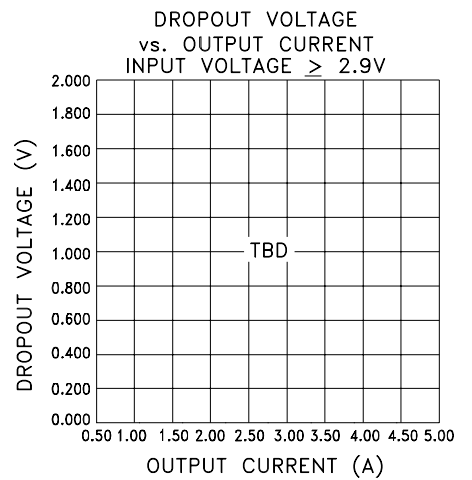
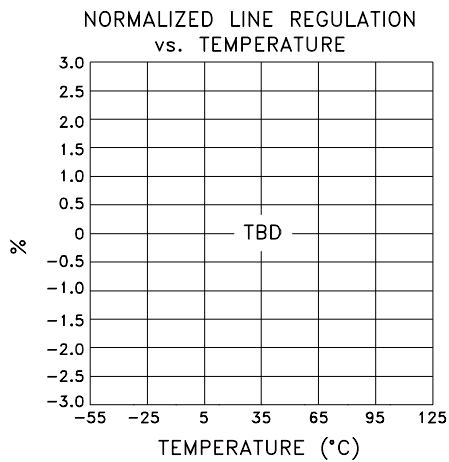
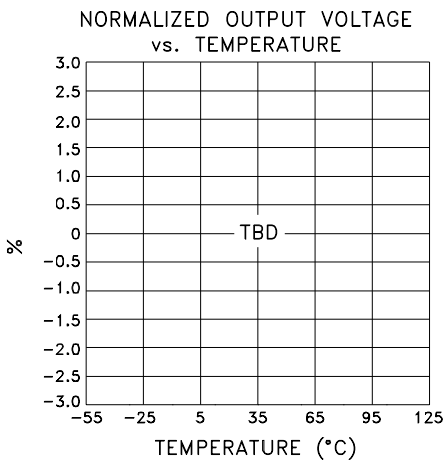
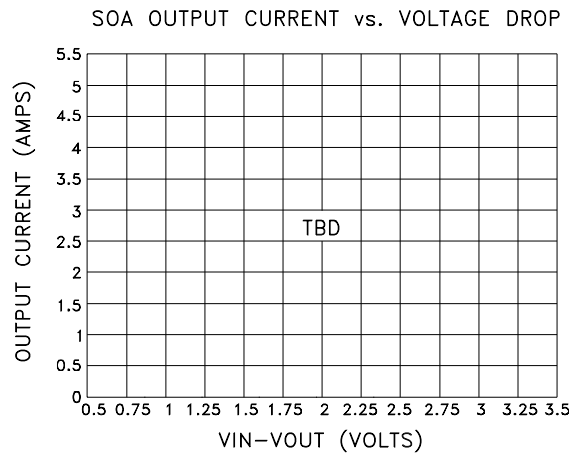
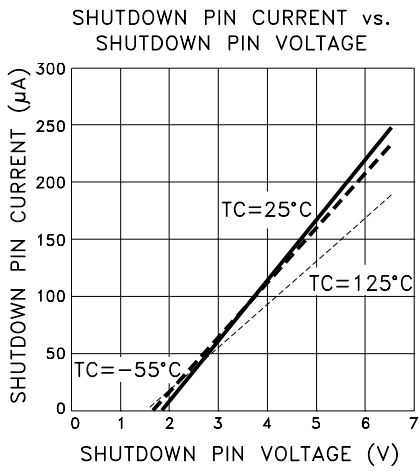
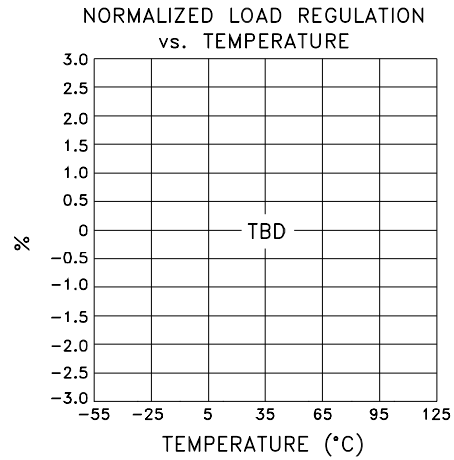
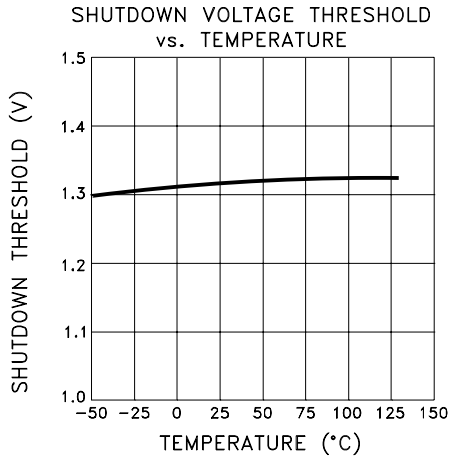

TYPICAL PERFORMANCE CURVES

MSK5824RH GAIN AND PHASE vs. FREQUENCY

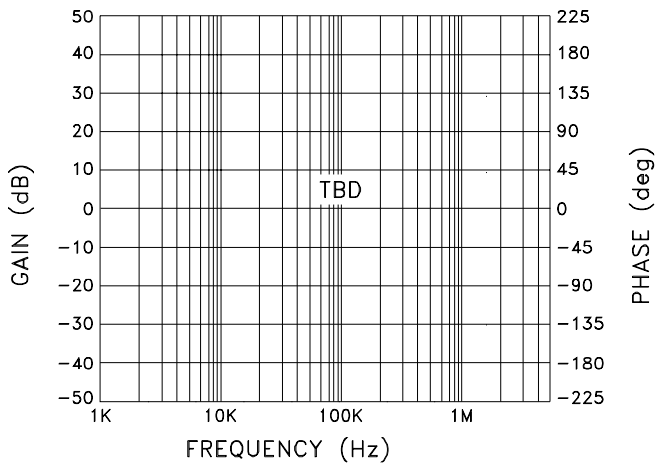

MSK5824RH GAIN AND PHASE vs. FREQUENCY

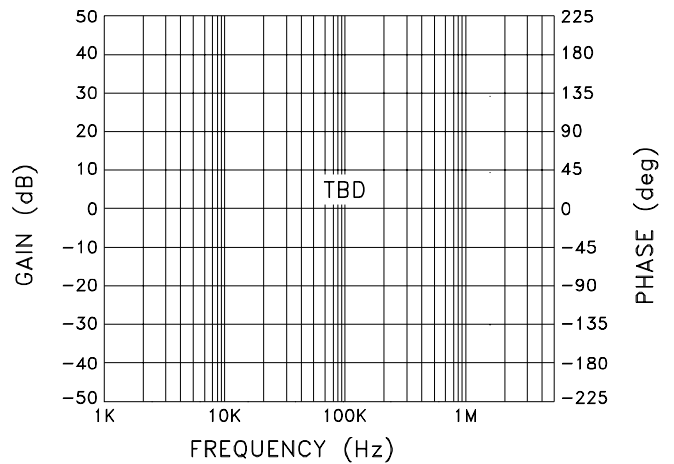

MSK5824RH GAIN AND PHASE vs. FREQUENCY

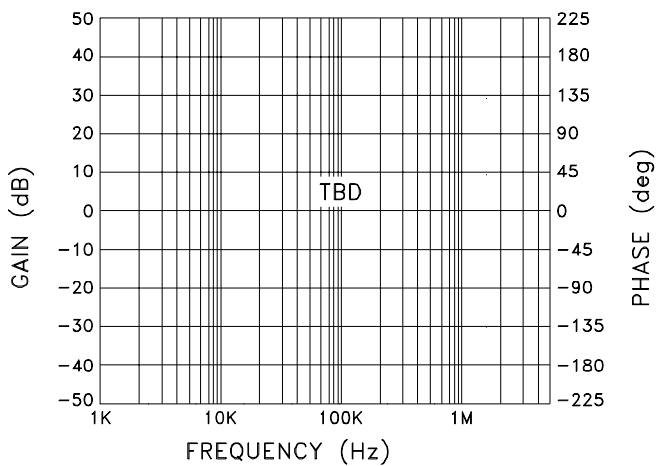

MSK5824RH GAIN AND PHASE vs. FREQUENCY

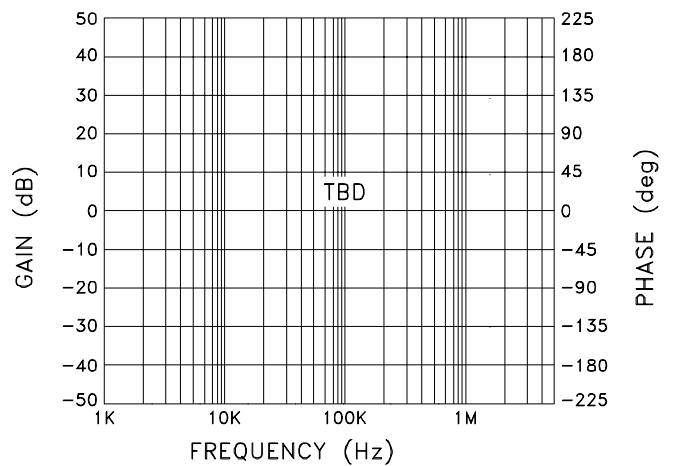

MSK5824RH GAIN AND PHASE vs. FREQUENCY

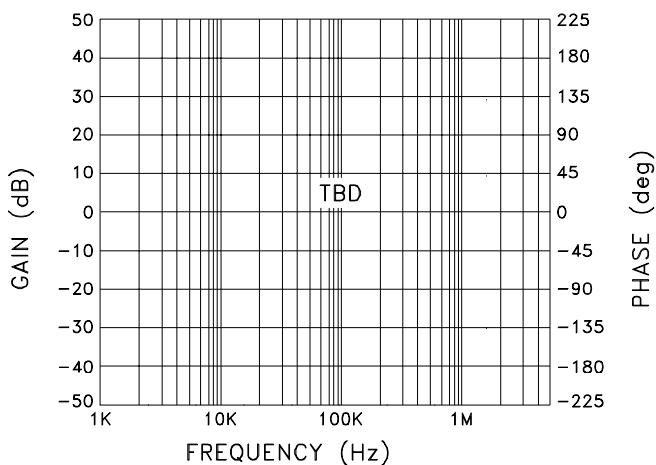

MSK5824RH GAIN AND PHASE vs. FREQUENCY

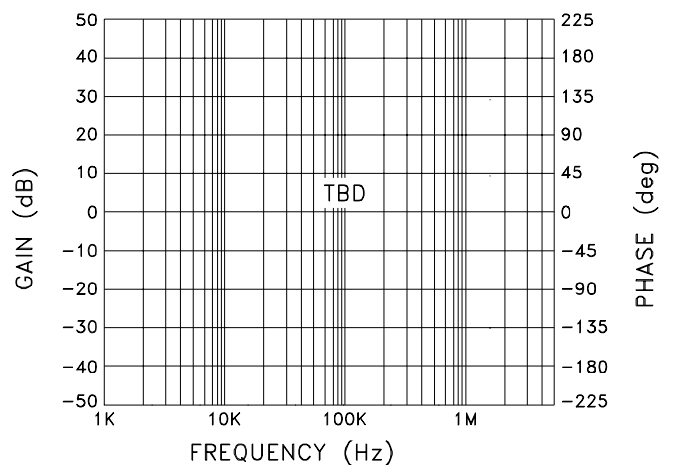

MECHANICAL SPECIFICATIONS

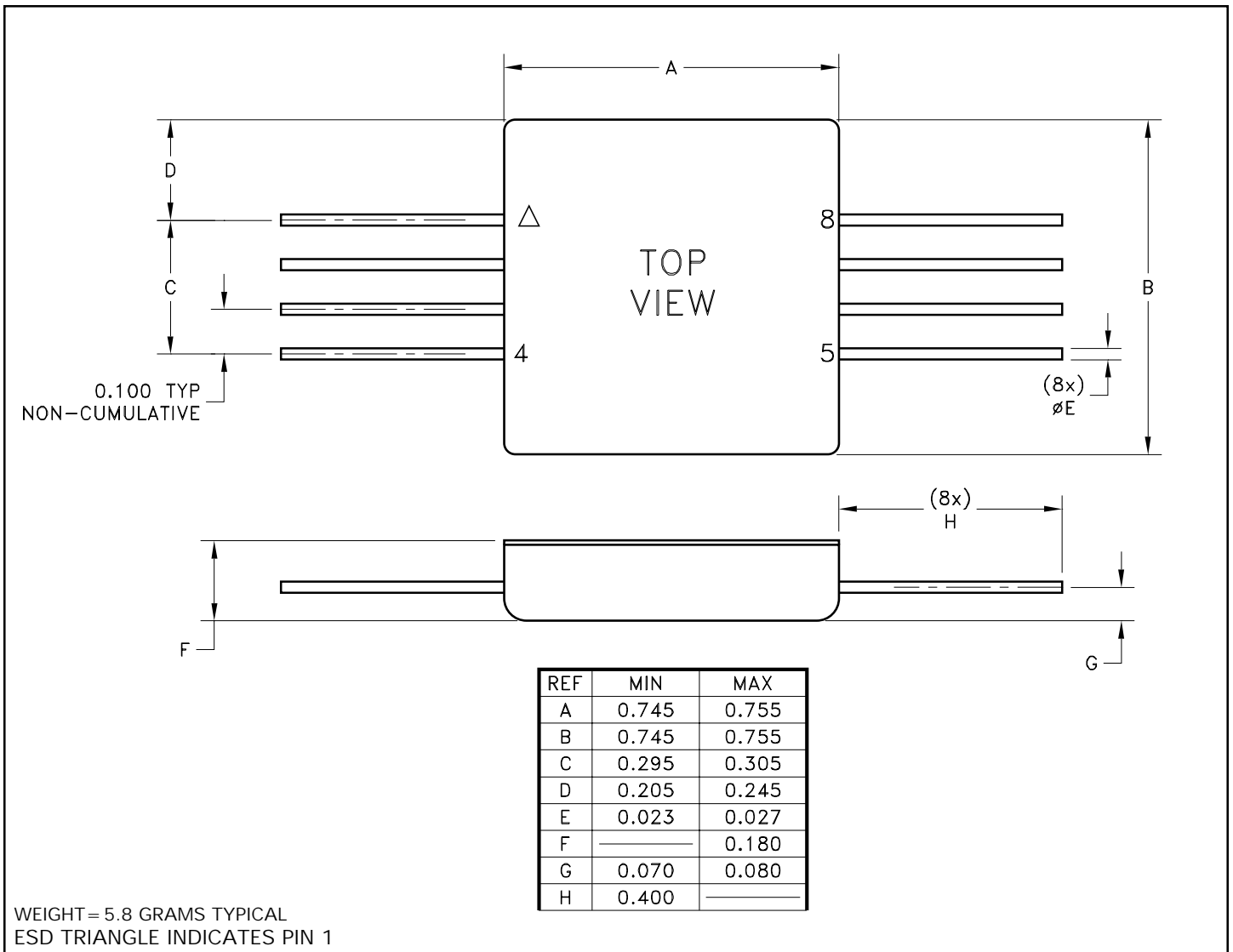

ORDERING INFORMATION

MSK5824 K RH

LEAD CONFIGURATIONS
 BLANK = STRAIGHT
 RADIATION HARDENED
 SCREENING
 BLANK = INDUSTRIAL; E = EXTENDED RELIABILITY
 H = MIL-PRF-38534 CLASS H; K = MIL-PRF-38534 CLASS K
 GENERAL PART NUMBER

The above example is a Class K regulator with straight leads.
 NOTE: See DSCC SMD 5962F09208 for DSCC part number options.

MECHANICAL SPECIFICATIONS

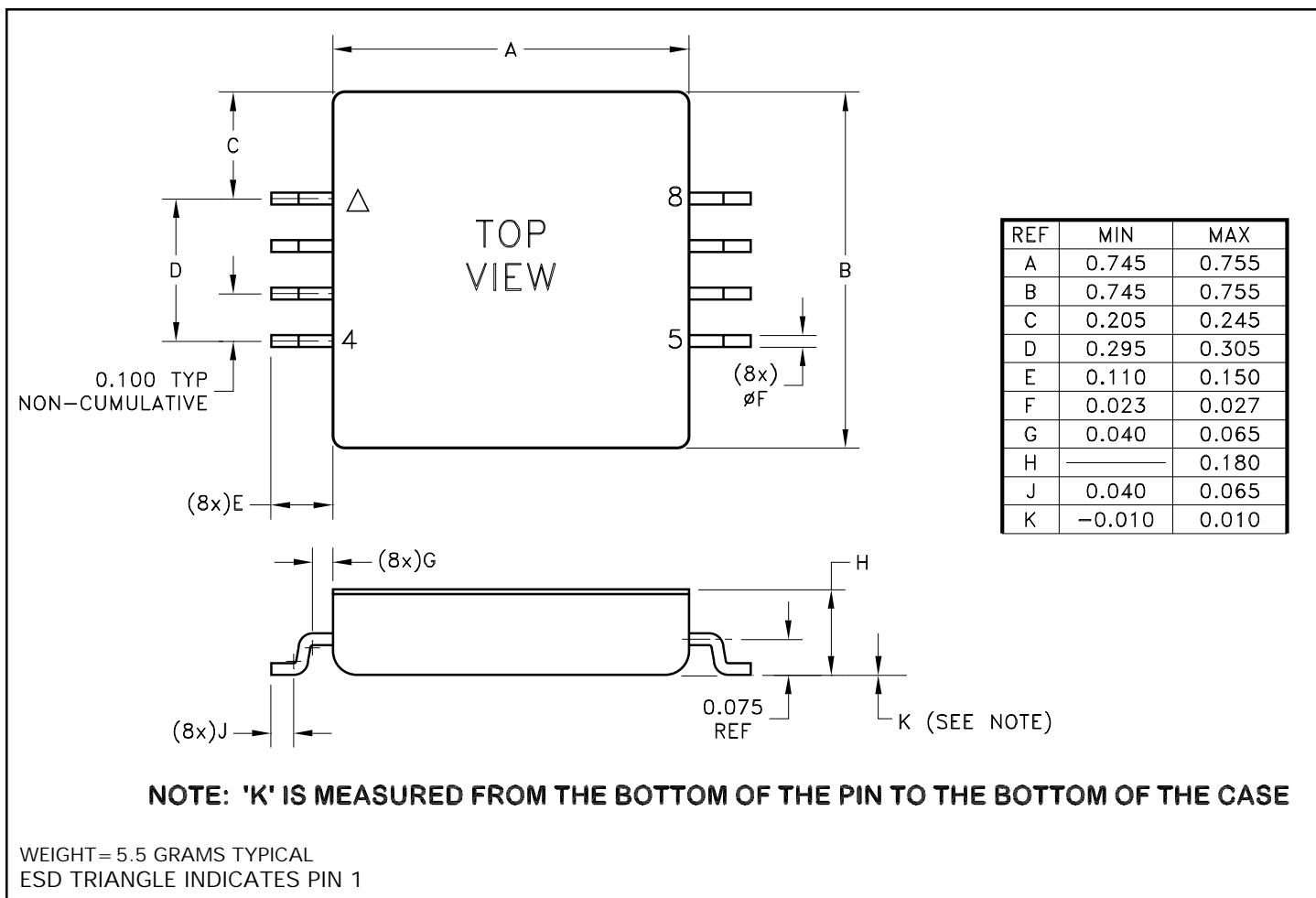

ORDERING INFORMATION

MSK5824 K RH G

LEAD CONFIGURATIONS

G = GULL WING

RADIATION HARDENED

SCREENING

BLANK = INDUSTRIAL; E = EXTENDED RELIABILITY

H = MIL-PRF-38534 CLASS H; K = MIL-PRF-38534 CLASS K

GENERAL PART NUMBER

The above example is a Class K regulator with gull wing formed leads.

NOTE: See DSCC SMD 5962F09208 for DSCC part number options.

M.S. Kennedy Corp.
4707 Dey Road, Liverpool, New York 13088
Phone (315) 701-6751
FAX (315) 701-6752
www.mskennedy.com

The information contained herein is believed to be accurate at the time of printing. MSK reserves the right to make changes to its products or specifications without notice, however, and assumes no liability for the use of its products.

Please visit our website for the most recent revision of this datasheet.

Contact MSK for MIL-PRF-38534 Class H, Class K status.