



M.S.KENNEDY CORP.

**RAD HARD POSITIVE,
1.0 AMP, SINGLE RESISTOR
ADJ VOLTAGE REGULATOR**

5976RH

4707 Dey Road Liverpool, N.Y. 13088

(315) 701-6751

FEATURES:

- Manufactured using  Space Qualified RH3080 Die
- MIL-PRF-38535 Class V Processing & Screening
- Total Dose Tested to TBD Krads(Si) (Method 1019.7 Condition A)
- Output Adjustable to Zero Volts
- Internal Short Circuit Current Limit
- Output Voltage is Adjustable with 1 External Resistor
- Output Current Capability to 1.0 Amps
- Internal Thermal Overload Protection
- Outputs may be Paralleled for Higher Current
- Available in 3 Lead Form Options: Straight, Up and Down
- Contact MSK for MIL-PRF-38535 Qualification and Radiation Status

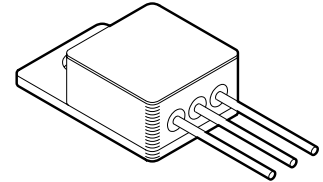

DESCRIPTION:

The MSK 5976RH offers an output voltage range down to zero volts while offering radiation tolerance for space applications. This, combined with the low θ_{JC} , allows increased output current while providing exceptional device efficiency. Because of the increased efficiency, a small hermetic 3 pin package can be used providing maximum performance while occupying minimal board space. Output voltage is selected by the user through the use of 1 external resistor. Additionally, the regulator offers internal short circuit current and thermal limiting, which allows circuit protection and eliminates the need for external components and excessive derating.

EQUIVALENT SCHEMATIC

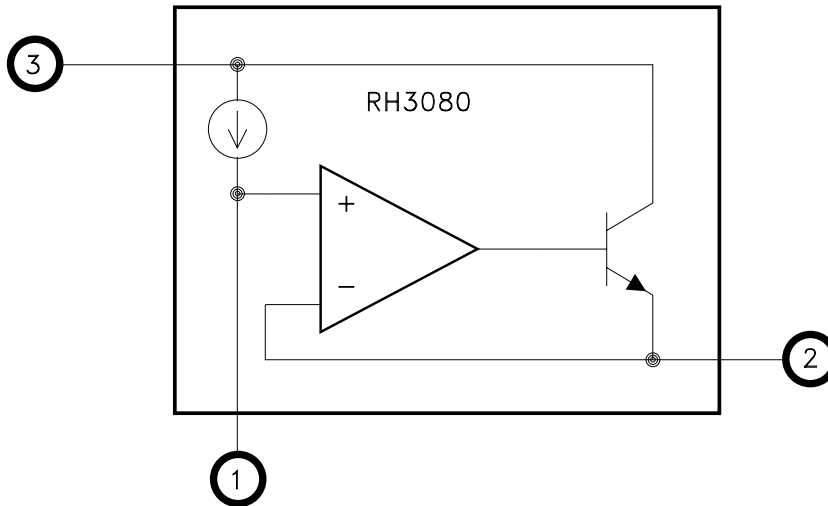

TYPICAL APPLICATIONS

- High Efficiency Linear Regulators
- Constant Voltage/Current Regulators
- Space System Power Supplies
- Switching Power Supply Post Regulators
- Very low Voltage Power Supplies

PIN-OUT INFORMATION

- 1 SET
- 2 VOUT
- 3 VIN

(CASE IS ISOLATED)

 and the Linear Technology logo are registered trademarks and RH3080 is a copyright of Linear Technology Corporation

ABSOLUTE MAXIMUM RATINGS ^⑦

V _{IN}	Input Voltage	40V	T _{ST}	Storage Temperature Range	-65 °C to + 150 °C
P _D	Power Dissipation	Internally Limited	T _{LD}	Lead Temperature Range	300 °C
I _{OUT}	Output Current ^⑦	1.0A		(10 Seconds)	
T _J	Junction Temperature	+ 150 °C	T _c	Case Operating Temperature	
				MSK 5976RH	-40 °C to + 85 °C
				MSK 5976V RH.	-55 °C to + 125 °C

ELECTRICAL SPECIFICATIONS

Parameter	Test Conditions	Group A Subgroup	MSK 5976V RH			MSK 5976RH			Units
			Min.	Typ.	Max.	Min.	Typ.	Max.	
Set Pin Current (I _{set})	V _{in} = 3.0V V _{out} = 1.0V I _{mA} < I _{LOAD} < 1.0A	1	9.80	10.0	10.20	9.80	10.0	10.20	µA
		2,3	9.80	-	10.20	-	-	-	µA
		Post Radiation	1	TBD	TBD	TBD	TBD	TBD	TBD
Output Offset Voltage (V _{os})	V _{in} = 3.0V V _{out} = 1.0V I _{LOAD} = 1mA	1	-5	0	5	-5	0	5	mV
		2,3	-6	-	6	-	-	-	mV
Load Regulation (ΔV _{os}) (ΔI _{set}) ^②	V _{in} = 3.0V V _{out} = 1.0V 1mA < I _{Load} < 1.0A	1	-	-	1.3	-	-	1.3	mV
		2,3	-	-	1.3	-	-	-	mV
		1	-	-0.1	-	-	-0.1	-	nA
Line Regulation (Δ I _{set}) (Δ V _{os}) ^②	3V < V _{in} < 25V V _{out} = 1.0V I _{Load} = 1mA	1	-	-	0.5	-	-	0.5	nA/V
		2,3	-	-	0.5	-	-	-	nA/V
		1	-	0.003	-	-	0.003	-	mV/V
Dropout Voltage	V _{out} = 1.0V I _{Load} = 1.0A	1	-	TBD	1.6	-	-	1.6	V
		2,3	-	-	1.6	-	-	-	V
Current Limit	V _{in} = 5.0V V _{out} = 1.0V	1	1.0	TBD	-	1.0	-	-	A
		2,3	1.0	-	-	-	-	-	A
		Post Radiation	1	TBD	TBD	TBD	TBD	TBD	TBD
Minimum Load Current ^⑥	V _{in} = 25V	-	-	-	1	-	-	1	mA
Ripple Rejection ^②	F = 120Hz Δ V _{in} = 0.5V _{pp}	-	-	75	-	-	75	-	dB
Thermal Resistance ^②	Junction to Case @125 °C	-	-	6.4	7.3	-	6.4	7.3	°C/W

NOTES:

- ① Output is decoupled to ground using a 3.3 tantalum low ESR capacitor in parallel with a 0.1µF ceramic capacitor unless otherwise specified. (See Figure 1).
- ② Guaranteed by design but not tested. Typical parameters are representative of actual device performance but are for reference only.
- ③ Industrial grade devices shall be tested to subgroup 1 unless otherwise specified.
- ④ Class V devices shall be 100% tested to subgroups 1,2 and 3.
- ⑤ Subgroup 1 TA = TC = + 25 °C
Subgroup 2 TA = TC = + 125 °C
Subgroup 3 TA = TC = -55 °C
- ⑥ Minimum load current verified while testing line regulation.
- ⑦ Continuous operation at or above absolute maximum ratings may adversely effect the device performance and/or life cycle.
- ⑧ Pre and Post irradiation limits at 25 °C, up to TBD TID, are identical unless otherwise specified.

OUTPUT VOLTAGE

A single resistor (R_{set}) from the SET pin to ground creates the reference voltage for the internal Error Amplifier. The MSK 5976RH SET pin supplies a constant current of 10uA that develops the reference voltage. The output voltage is simply $R_{set} \times 10\mu A$. Since the output is internally driven by a unity-gain amplifier, an alternative to using R_{set} is to connect a high quality reference source to the SET pin. With a minimum load requirement of 1mA on the Output, the Output Voltage can be adjusted to near 0V. To bring the output voltage to 0V, the load must be connected to a slightly negative voltage supply to sink the 1mA minimum load current from a 0V output.

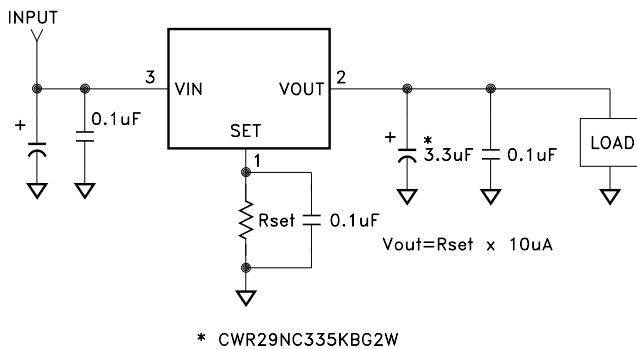

FIGURE 1

OUTPUT CAPACITANCE

For stability purposes, the MSK 5976RH requires a minimum output capacitor of 2.2µF with an ESR of 0.5Ω or less. Tantalum or ceramic capacitors are recommended. A larger capacitance value will improve transient response for increased load current changes. Consideration must also be given to temperature characteristics of the capacitors used.

ADDITIONAL STABILITY

A capacitor placed in parallel with the SET pin resistor to ground, will improve the output transient response and filter noise in the system. To reduce output noise, typically less than 100pF is all that will be required. Capacitors up to 1µF can be used, however consideration must be given to the effect the time constant created will have on the startup time.

LOAD REGULATION

The MSK 5976RH specified load regulation is Kelvin Sensed, therefore the parasitic resistance of the system must be considered to design an acceptable load regulation. The overall load regulation includes the specified MSK 5976RH load regulation plus the parasitic resistance multiplied by the load current as shown in Figure 2. R_{so} is the series resistance of all conductors between the MSK 5976RH output and the load. It will directly increase output load regulation error by a voltage drop of $\Delta I_o \times R_{so}$. R_{ss} is the series resistance between the set pin and the load. R_{ss} will have little effect on load regulation if the set pin trace is connected as close to the load as possible keeping the load return current on a separate trace as shown. R_{sr} is the series resistance of all of the conductors between the load and the input power source return. R_{sr} will not effect load regulation if the set pin is connected with a Kelvin Sense type connection as shown in Figure 2, but it will increase the effective dropout voltage by a factor of $I_o \times R_{sr}$. Keeping R_{so} and R_{sr} as low as possible will ensure minimal voltage drops and wasted power.

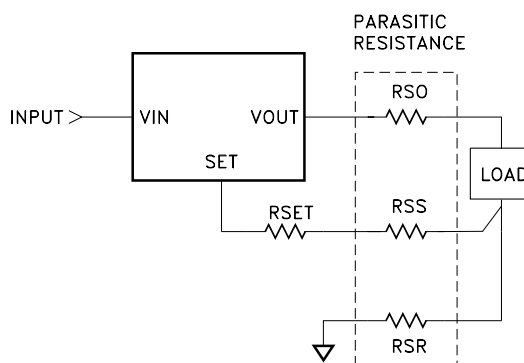

FIGURE 2

PARALLELING DEVICES

When currents greater than 1.0 A are needed, the MSK 5976RH's may be paralleled to multiply the current capacity. As shown in Figure 3, the Vin and SET pins must be tied together. The Vout pins are connected to the load with consideration to the conductor resistance. The conductor resistance of each MSK 5976RH Vout connection to the load, must be equal to create equal load sharing. As little as 10mΩ ballast resistance typically ensures better than 80% equal sharing of load current at full load. Additional consideration must be given to the effect the additional Vout conductor resistance has on load regulation; see paragraph titled "Load Regulation".

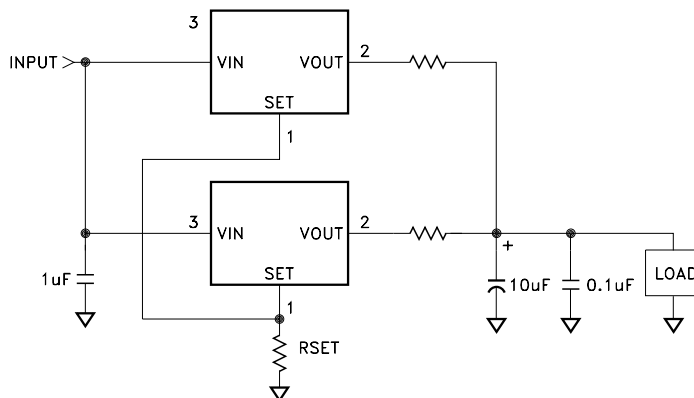

FIGURE 3

IMPROVING INITIAL ACCURACY AND REDUCING TEMPERATURE DRIFT

The initial output accuracy of the MSK 5976RH due to set pin current tolerance and set point resistor accuracy can be reduced to 0.2% using the MSK 109RH radiation hardened precision reference. Minimal drift of the MSK 109RH from temperature extremes and irradiation ensure very tight regulation. The circuit can be configured to use the 2.5V reference to directly set the output at 2.5V or with a slight variation it can provide any output within the operating range of the MSK 5976RH down to 0V output. Select R_s to maintain between 1mA and 10mA of current through the reference; see Figure 4 below. R_s may be tied to V_{in} or another power source. The optional trim resistor can be used to further trim out initial output and system error. Reference the MSK 109RH data sheet for application circuits that provide stable output voltages across the full operating range of the MSK 5976RH including down to 0V output and the operating characteristics of the MSK 109RH.

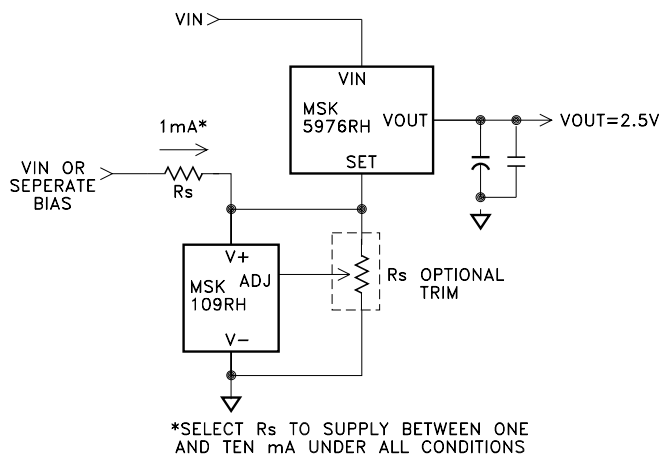

FIGURE 4

ADDING SHUTDOWN

The MSK 5976RH can be easily shutdown by either reducing R_{set} to 0Ω or connecting a transistor from the set pin to ground. By connecting two transistors, as shown in Figure 5, a low current voltage source is all that is required to take the set pin to ground as well as pull the output voltage to ground. Q2 pulls the output voltage to ground when no load is present and only needs to sink 10mA. Use a low leakage switching diode between V_{out} and Set to avoid overstress during shutdown transitions.

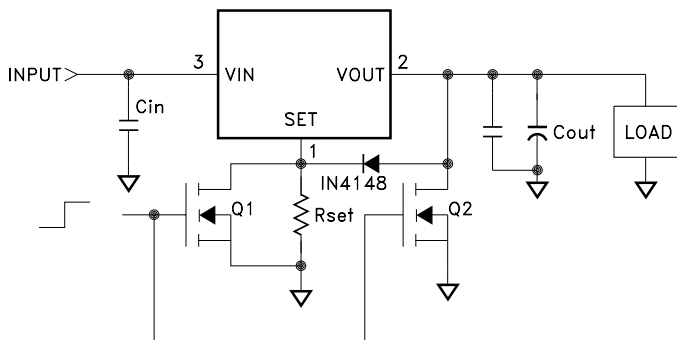

FIGURE 5

HEAT SINKING

To determine if a heat sink is required for your application and if so, what type, refer to the thermal model and governing equation below.

$$\text{Governing Equation: } T_j = P_d \times (R_{\theta jc} + R_{\theta cs} + R_{\theta sa}) + T_a$$

WHERE

- T_j = Junction Temperature
- P_d = Total Power Dissipation
- $R_{\theta jc}$ = Junction to Case Thermal Resistance
- $R_{\theta cs}$ = Case to Heat Sink Thermal Resistance
- $R_{\theta sa}$ = Heat Sink to Ambient Thermal Resistance
- T_c = Case Temperature
- T_a = Ambient Temperature
- T_s = Heat Sink Temperature

EXAMPLE:

This example demonstrates the thermal calculations for the TO-257 package with the regulator operating at one-half of its maximum rated output current.

Conditions for MSK 5976RH:

$$V_{in} = +3.0V; I_{out} = +0.50A \quad V_{out} = +1.0V$$

- 1.) Assume 45° heat spreading model.
- 2.) Find regulator power dissipation:

$$\begin{aligned} P_d &= (V_{in} - V_{out})(I_{out}) \\ P_d &= (3-1)(0.50) \\ &= 1.0W \end{aligned}$$

- 3.) For conservative design, set $T_j = +125^\circ\text{C Max.}$
- 4.) For this example, worst case $T_a = +90^\circ\text{C.}$
- 5.) $R_{\theta jc} = 7.3^\circ\text{C/W}$ from the Electrical Specification Table.
- 6.) $R_{\theta cs} = 0.15^\circ\text{C/W}$ for most thermal greases.
- 7.) Rearrange governing equation to solve for $R_{\theta sa}$:

$$\begin{aligned} R_{\theta sa} &= ((T_j - T_a)/P_d) - (R_{\theta jc}) - (R_{\theta cs}) \\ &= (125^\circ\text{C} - 90^\circ\text{C})/1.0W - 7.3^\circ\text{C/W} - 0.15^\circ\text{C/W} \\ &= 27.6^\circ\text{C/W} \end{aligned}$$

In this case the result is 27.6°C/W. Therefore, a heat sink with a thermal resistance of no more than 27.6°C/W must be used in this application to maintain regulator circuit junction temperature under 125°C.

TOTAL DOSE RADIATION TEST PERFORMANCE

Radiation performance curves for TID testing will be generated for all radiation testing performed by MS Kennedy. These curves show performance trends throughout the TID test process and can be located in the MSK 5976RH radiation test report. The complete radiation test report will be available in the RAD HARD PRODUCTS section on the MSK website.

ADDITIONAL APPLICATION INFORMATION

For additional applications information, please reference Linear Technology Corporation's® LT3080 and RH3080 data sheets.

TYPICAL PERFORMANCE CURVES

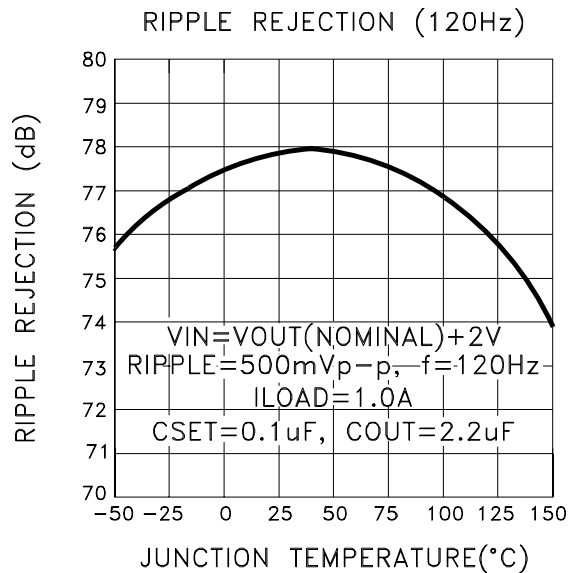
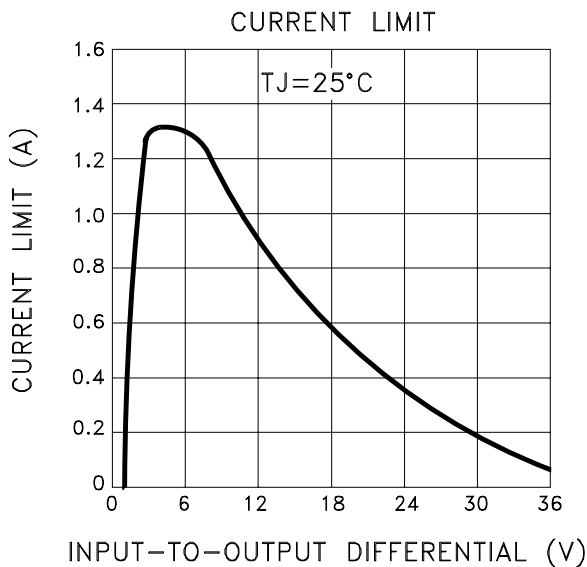
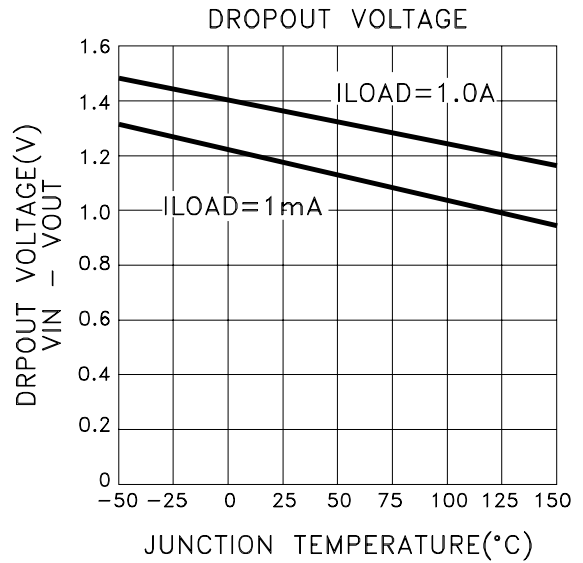
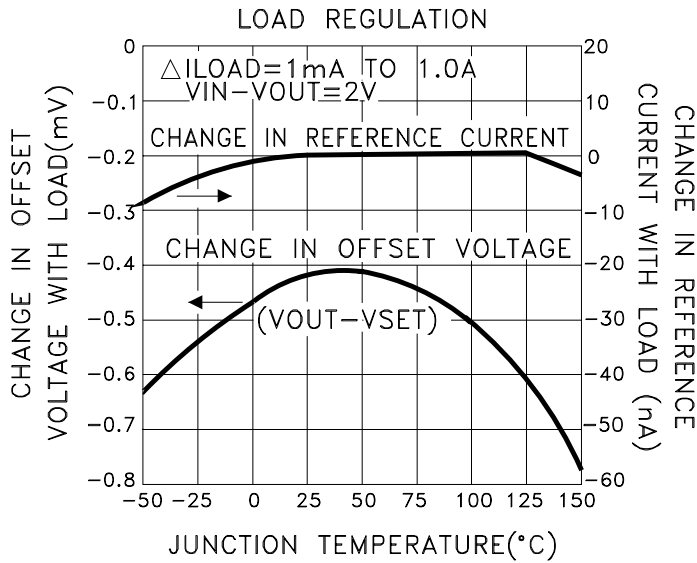
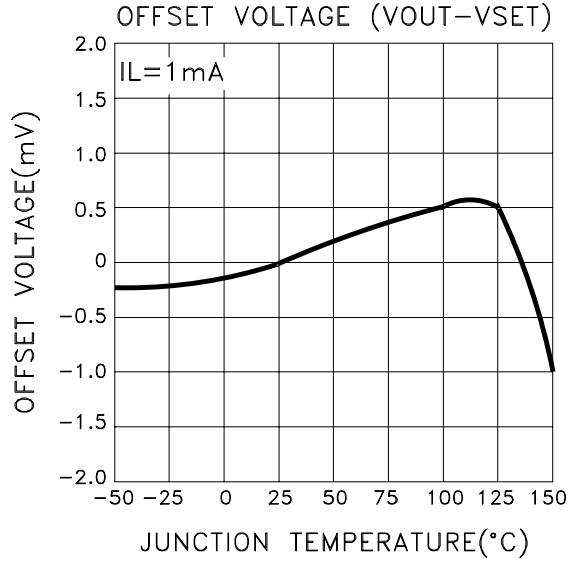
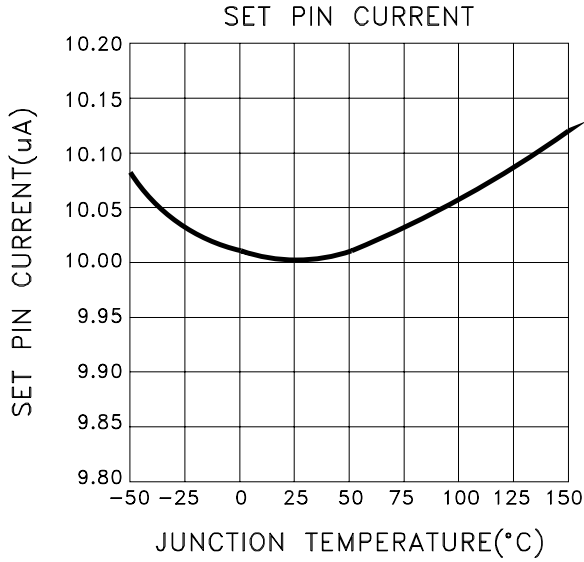

MECHANICAL SPECIFICATIONS

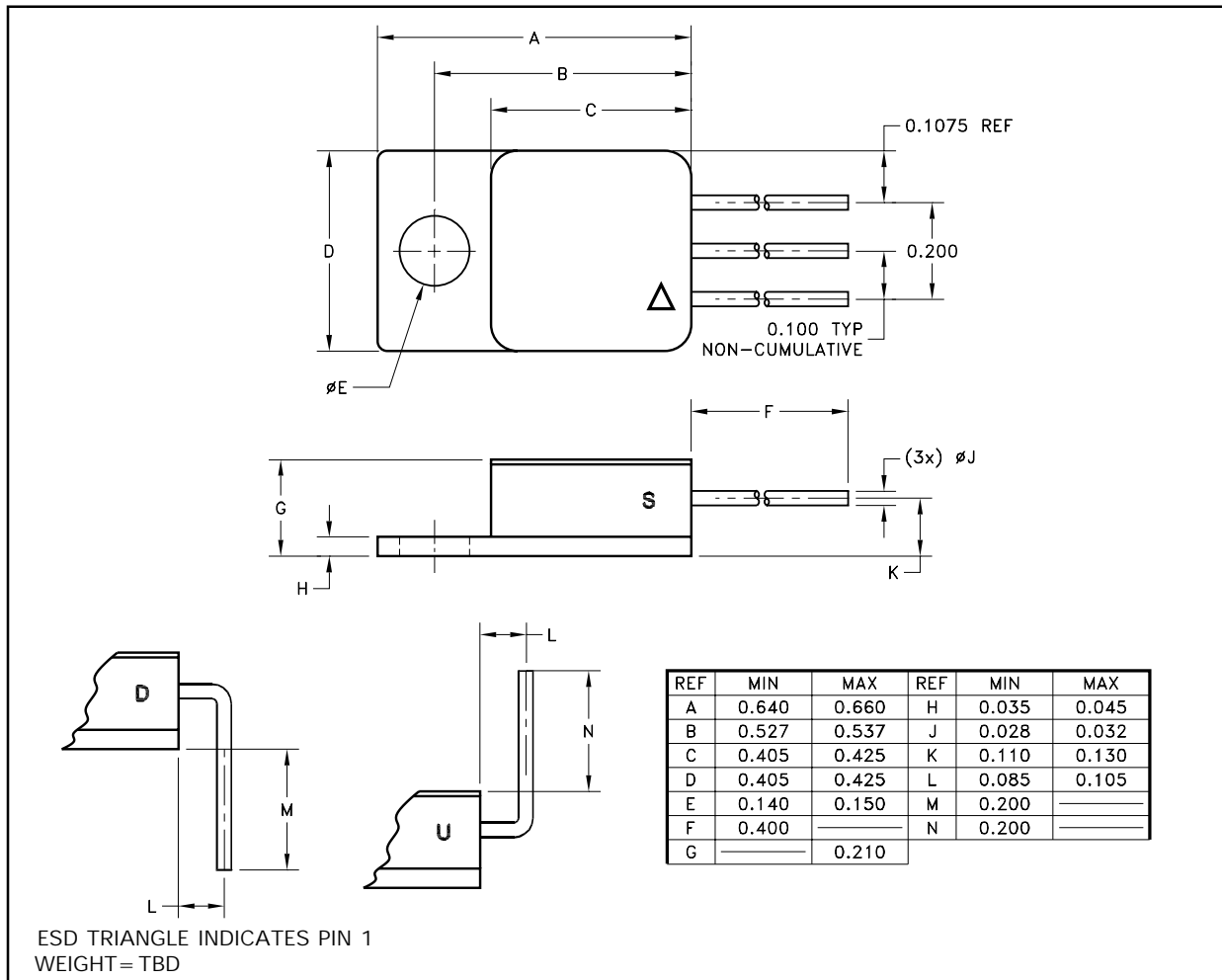

ORDERING INFORMATION

MSK5976 V RH U

- LEAD CONFIGURATIONS
S = STRAIGHT; U = BENT UP; D = BENT DOWN
- RADIATION HARDENED
- SCREENING
BLANK = INDUSTRIAL
V = MIL-PRF-38535 CLASS V
- GENERAL PART NUMBER

The above example is an adjustable Class V regulator with leads bent up.

M.S. Kennedy Corp.
4707 Dey Road, Liverpool, New York 13088
Phone (315) 701-6751
FAX (315) 701-6752
www.mskennedy.com

The information contained herein is believed to be accurate at the time of printing. MSK reserves the right to make changes to its products or specifications without notice, however, and assumes no liability for the use of its products. Please visit our website for the most recent revision of this datasheet.

Contact MSK for MIL-PRF-38535 Class V and radiation status.