

### FEATURES

- Operates at Supply Voltages From 2.0 V to 30 V
- Consumes Only 110  $\mu$ A Supply Current
- Step-Up or Step-Down Mode Operation
- Minimum External Components Required
- Low Battery Detector Comparator On-Chip
- User-Adjustable Current Limit
- Internal 1 A Power Switch
- Fixed or Adjustable Output Voltage Versions
- 8-Pin DIP or SO-8 Package

### APPLICATIONS

- Notebook/Palm Top Computers
- 3 V to 5 V, 5 V to 12 V Converters
- 9 V to 5 V, 12 V to 5 V Converters
- LCD Bias Generators
- Peripherals and Add-On Cards
- Battery Backup Supplies
- Cellular Telephones
- Portable Instruments

### GENERAL DESCRIPTION

The ADP1108 is a highly versatile micropower switch-mode dc-dc converter that operates from an input voltage supply as low as 2.0 V and typically starts up from 1.8 V.

The ADP1108 can be programmed into a step-up or step-down dc-to-dc converter with only three external components. The fixed outputs are 3.3 V, 5 V and 12 V. An adjustable version is also available. In step-up mode, supply voltage range is 2.0 V to 12 V, and 30 V in step-down mode. The ADP1108 can deliver 150 mA at 5 V from a 2 AA cell input and 300 mA at 5 V from a 9 V input in step-down mode. Switch current limit can be programmed with a single resistor.

For battery operated and power conscious applications, the ADP1108 offers a very low power consumption of less than 110  $\mu$ A.

The auxiliary gain block available in ADP1108 can be used as a low battery detector, linear post regulator, under voltage lockout circuit or error amplifier.

### FUNCTIONAL BLOCK DIAGRAMS

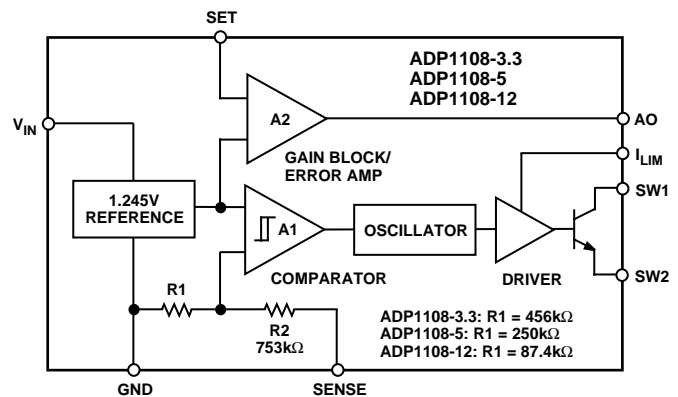
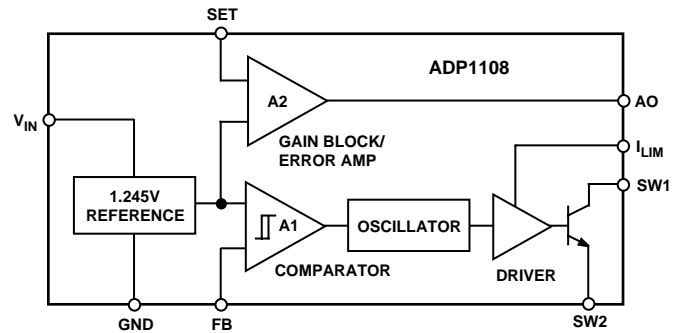

### REV. 0

Information furnished by Analog Devices is believed to be accurate and reliable. However, no responsibility is assumed by Analog Devices for its use, nor for any infringements of patents or other rights of third parties which may result from its use. No license is granted by implication or otherwise under any patent or patent rights of Analog Devices.

# ADP1108–SPECIFICATIONS (0°C to +70°C, $V_{IN} = 3.0\text{ V}$ unless otherwise noted)

Parameter	Symbol	Conditions	Min	Typ	Max	Units
QUIESCENT CURRENT	$I_Q$	Switch Off		90	150	$\mu\text{A}$
QUIESCENT CURRENT, BOOST MODE CONFIGURATION	$I_Q$	No Load, $T_A = +25^\circ\text{C}$ ADP1108-3.3 ADP1108-5 ADP1108-12		90 90 90		$\mu\text{A}$ $\mu\text{A}$ $\mu\text{A}$
INPUT VOLTAGE	$V_{IN}$	Step-Up Mode Step-Down Mode	2.0		12.6 30	V V
COMPARATOR TRIP POINT VOLTAGE		ADP1108 <sup>1</sup>	1.20	1.245	1.30	V
OUTPUT SENSE VOLTAGE	$V_{OUT}$	ADP1108-3.3 <sup>2</sup> ADP1108-5 <sup>2</sup> ADP1108-12 <sup>2</sup>	3.13 4.75 11.4	3.3 5.00 12.0	3.46 5.25 12.6	V V V
COMPARATOR HYSTERESIS		ADP1108		5	12	mV
OUTPUT HYSTERESIS		ADP1108-3.3 ADP1108-5 ADP1108-12		13 20 50	30 55 100	mV mV mV
OSCILLATOR FREQUENCY			14	19	25	kHz
DUTY CYCLE		Full Load	55	70	78	%
SWITCH ON TIME	$t_{ON}$	$I_{LIM}$ Tied to $V_{IN}$	25	36	48	$\mu\text{s}$
FEEDBACK PIN BIAS CURRENT		$V_{FB} = 0\text{ V}$		25	200	nA
SET PIN BIAS CURRENT		$V_{SET} = V_{REF}$		60	130	nA
GAIN BLOCK OUTPUT LOW	$V_{OL}$	$I_{SINK} = 100\ \mu\text{A}$ , $V_{SET} = 1.00\text{ V}$		0.15	0.4	V
REFERENCE LINE REGULATION		$2.0\text{ V} \leq V_{IN} \leq 5\text{ V}$ $5\text{ V} \leq V_{IN} \leq 30\text{ V}$		0.2 0.02	0.4 0.075	%/V %/V
$SW_{SAT}$ VOLTAGE, STEP-UP MODE	$V_{SAT}$	$V_{IN} = 3.0\text{ V}$ , $I_{SW} = 650\text{ mA}$ $V_{IN} = 5.0\text{ V}$ , $I_{SW} = 1\text{ A}$ , $T_A = +25^\circ\text{C}$		0.5 0.8	0.75 1.00	V V V
$SW_{SAT}$ VOLTAGE, $SAT$ STEP-DOWN MODE		$V_{IN} = 12\text{ V}$ , $I_{SW} = 650\text{ mA}$ , $T_A = +25^\circ\text{C}$		1.1	1.5 1.7	V V
GAIN BLOCK GAIN	$A_V$	$R_L = 100\text{K}^3$	400	1000		V/V
CURRENT LIMIT		$220\ \Omega$ from $I_{LIM}$ to $V_{IN}$ , $T_A = +25^\circ\text{C}$		500		mA
CURRENT LIMIT TEMPERATURE COEFFICIENT				-0.3		%/ $^\circ\text{C}$
SWITCH OFF LEAKAGE CURRENT		Measured at SW1 Pin, $T_A = +25^\circ\text{C}$		1	10	$\mu\text{A}$
MAXIMUM EXCURSION BELOW GND	$V_{SW2}$	$I_{SW1} \leq 10\ \mu\text{A}$ , Switch Off $T_A = +25^\circ\text{C}$		-400	-350	mV

## NOTES

<sup>1</sup>This specification guarantees that both the high and low trip points of the comparator fall within the 1.20 V to 1.30 V range.

<sup>2</sup>The output voltage waveform will exhibit a sawtooth shape due to the comparator hysteresis. The output voltage on the fixed output versions will always be within the specified range.

<sup>3</sup>100 k $\Omega$  resistor connected between a 5 V source and the AO pin.

All limits at temperature extremes are guaranteed via correlation using standard Quality Control methods.  
Specifications subject to change without notice.

### ABSOLUTE MAXIMUM RATINGS\*

Supply Voltage ( $V_{IN}$ )	+36 V
SW1 Pin Voltage ( $V_{SW1}$ )	+50 V
SW2 Pin Voltage ( $V_{SW2}$ )	-0.5 V to $V_{IN}$
Feedback Pin Voltage (ADP1108)	+5.5 V
Sense Pin Voltage (ADP1108, 3.3, 5, 12)	+36 V
Maximum Power Dissipation	500 mW
Maximum Switch Current	1.5 A
Operating Temperature Range	0°C to 170°C
Storage Temperature Range	-65°C to +150°C
Lead Temperature (Soldering, 10 sec)	+300°C

\*Stresses above those listed under Absolute Maximum Ratings may cause permanent damage to the device. This is a stress rating only; functional operation of the device at these or any other conditions above those listed in the operational sections of this specification is not implied. Exposure to absolute maximum rating conditions for extended periods may affect device reliability.

### PIN CONFIGURATIONS

**8-Lead Plastic DIP  
(N-8)**

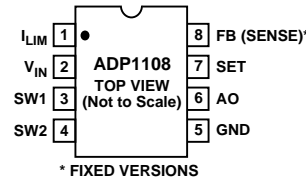

**8-Lead SOIC  
(SO-8)**

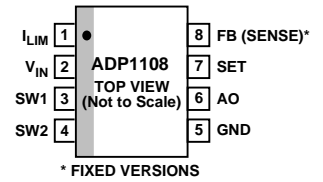

### ORDERING GUIDE

Model	Output Voltage	Package*
ADP1108AN	ADJ	N-8
ADP1108AR	ADJ	SO-8
ADP1108AN-3.3	3.3 V	N-8
ADP1108AR-3.3	3.3 V	SO-8
ADP1108AN-5	5 V	N-8
ADP1108AR-5	5 V	SO-8
ADP1108AN-12	12 V	N-8
ADP1108AR-12	12 V	SO-8

\*N = Plastic DIP, SO = Small Outline Package.

### PIN FUNCTION DESCRIPTIONS

Mnemonic	Function
$I_{LIM}$	For normal conditions this pin is connected to $V_{IN}$ . When lower current is required, a resistor should be connected between $I_{LIM}$ and $V_{IN}$ . Limiting the switch current to 400 mA is achieved by connecting a 220 $\Omega$ resistor.
$V_{IN}$	Input Voltage.
SW1	Collector of Power Transistor. For step-down configuration, connect to $V_{IN}$ . For step-up configuration, connect to an inductor/diode.
SW2	Emitter of Power Transistor. For step-down configuration, connect to inductor/diode. For step-up configuration, connect to ground. Do not allow this pin to go more than a diode drop below ground.
GND	Ground.
AO	Auxiliary Gain (GB) Output. The open collector can sink 100 $\mu$ A.
SET	Gain Amplifier Input. The amplifier has positive input connected to SET pin and negative input connected to 1.245 V reference.
FB/SENSE	On the ADP1108 (adjustable) version this pin is connected to the comparator input. On the ADP1108-3.3, ADP1108-5 and ADP1108-12, the pin goes directly to the internal application resistor that set output voltage.

### CAUTION

ESD (electrostatic discharge) sensitive device. Electrostatic charges as high as 4000 V readily accumulate on the human body and test equipment and can discharge without detection. Although the ADP1108 features proprietary ESD protection circuitry, permanent damage may occur on devices subjected to high energy electrostatic discharges. Therefore, proper ESD precautions are recommended to avoid performance degradation or loss of functionality.



# ADP1108–Typical Performance Characteristics

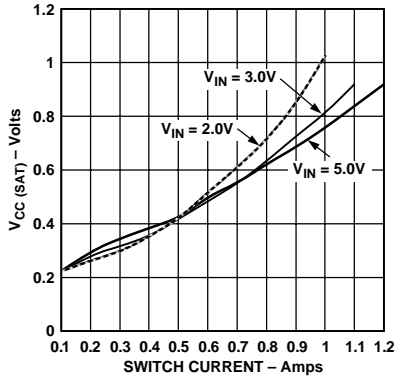

Figure 1. Saturation Voltage vs.  $I_{SWITCH}$  Current in Step-Up Mode

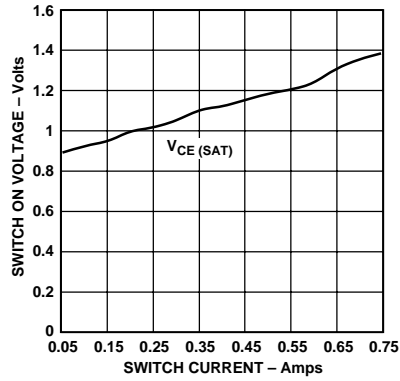

Figure 2. Switch ON Voltage vs. Switch Current In Step-Down Mode

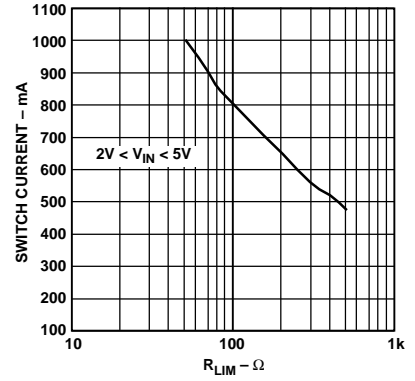

Figure 3. Maximum Switch Current vs.  $R_{LIM}$  In Step-Up Mode

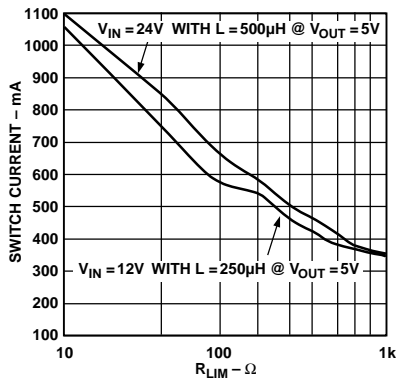

Figure 4. Maximum Switch Current vs.  $R_{LIM}$  In Step-Down Mode

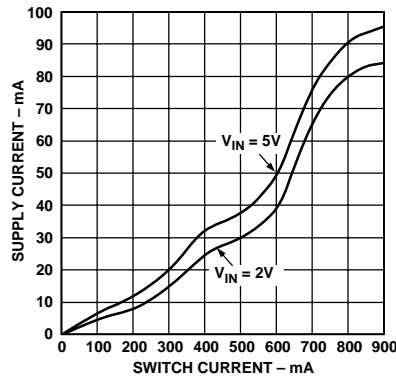

Figure 5. Supply Current vs. Switch Current

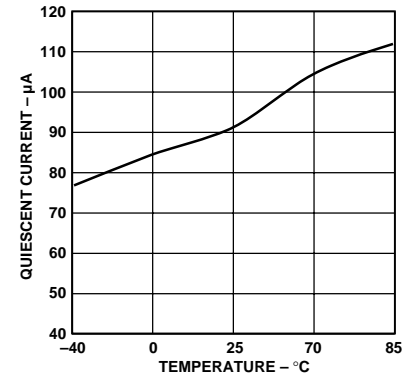

Figure 6. Quiescent Current vs. Temperature

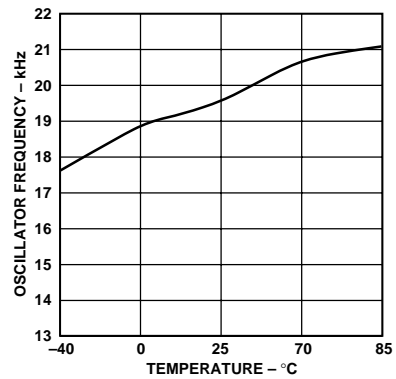

Figure 7. Oscillator Frequency vs. Temperature

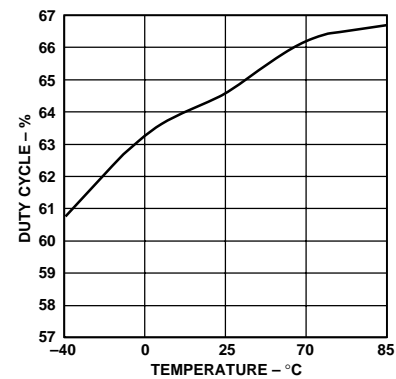

Figure 8. Duty Cycle vs. Temperature

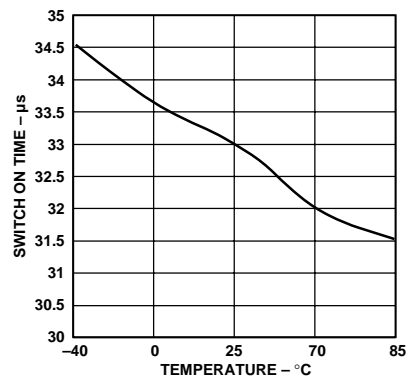

Figure 9. Switch ON Time vs. Temperature

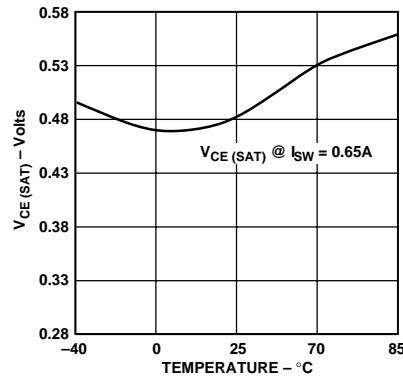

Figure 10. Switch Saturation Voltage In Step-Up Mode vs. Temperature

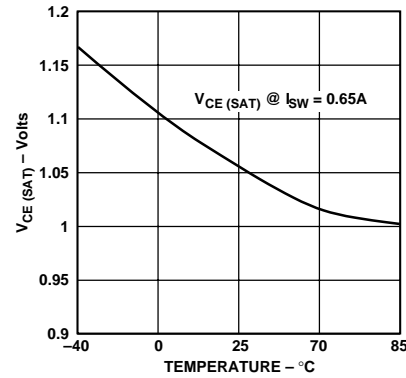

Figure 11. Switch Saturation Voltage In Step-Down Mode vs. Temperature

## THEORY OF OPERATION

The ADP1108 is a flexible, low power Switch Mode Power Supply (SMPS) controller. The regulated output voltage can be greater than the input voltage (boost or step-up mode) or less than the input (buck or step-down mode). This device uses a gated-oscillator technique to provide very high performance with low quiescent current.

A functional block diagram of the ADP1108 is shown on the front page. The internal 1.245 V reference is connected to one input of the comparator, while the other input is externally connected (via the FB pin) to a feedback network connected to the regulated output. When the voltage at the FB pin falls below 1.245 V, the 19 kHz oscillator turns on. A driver amplifier provides base drive to the internal power switch, and the switching action raises the output voltage. When the voltage at the FB pin exceeds 1.245 V, the oscillator is shut off. While the oscillator is off, the ADP1108 quiescent current is only 110  $\mu$ A. The comparator includes a small amount of hysteresis, which ensures loop stability without requiring external components for frequency compensation.

The maximum current in the internal power switch can be set by connecting a resistor between  $V_{IN}$  and the  $I_{LIM}$  pin. When the maximum current is exceeded, the switch is turned OFF. The current limit circuitry has a time delay of about 2  $\mu$ s. If an external resistor is not used, connect  $I_{LIM}$  to  $V_{IN}$ . Further information on  $I_{LIM}$  is included in the Limiting the Switch Current section of this data sheet.

The ADP1108 internal oscillator provides 36  $\mu$ s ON and 17  $\mu$ s OFF times, which is ideal for applications where the ratio between  $V_{IN}$  and  $V_{OUT}$  is roughly a factor of three (such as generating +5 V from a +2 V input). The 36  $\mu$ s/17  $\mu$ s ratio permits continuous mode operation in such cases, which increases the available output power.

An uncommitted gain block on the ADP1108 can be connected as a low-battery detector. The inverting input of the gain block is internally connected to the 1.245 V reference. The noninverting input is available at the SET pin. A resistor divider, connected between  $V_{IN}$  and GND with the junction connected to the SET pin, causes the AO output to go LOW when the low battery set point is exceeded. The AO output is an open collector NPN transistor that can sink 100  $\mu$ A.

The ADP1108 provides external connections for both the collector and emitter of its internal power switch, which permits both step-up and step-down modes of operation. For the step-up mode, the emitter (Pin SW2) is connected to GND and the collector (Pin SW1) drives the inductor. For step-down mode, the emitter drives the inductor while the collector is connected to  $V_{IN}$ .

The output voltage of the ADP1108 is set with two external resistors. Three fixed-voltage models are also available: ADP1108-3.3 (+3.3 V), ADP1108-5 (+5 V) and ADP1108-12 (+12 V). The fixed-voltage models are identical to the ADP1108, except that laser-trimmed voltage-setting resistors are included on the chip. On the fixed-voltage models of the ADP1108, simply connect the feedback pin (Pin 8) directly to the output voltage.

## COMPONENT SELECTION

### General Notes on Inductor Selection

When the ADP1108 internal power switch turns on, current begins to flow in the inductor. Energy is stored in the inductor core while the switch is on, and this stored energy is then transferred to the load when the switch turns off. Both the collector and the emitter of the switch transistor are accessible on the ADP1108, so the output voltage can be higher, lower, or of opposite polarity than the input voltage.

To specify an inductor for the ADP1108, the proper values of inductance, saturation current, and dc resistance must be determined. This process is not difficult, and specific equations for each circuit configuration are provided in this data sheet. In general terms, however, the inductance value must be low enough to store the required amount of energy (when both input voltage and switch ON time are at a minimum) but high enough that the inductor will not saturate when both  $V_{IN}$  and switch ON time are at their maximum values. The inductor must also store enough energy to supply the load, without saturating. Finally, the dc resistance of the inductor should be low, so that excessive power will not be wasted by heating the windings. For most ADP1108 applications, an inductor of 47  $\mu$ H to 330  $\mu$ H, with a saturation current rating of 300 mA to 1 A and dc resistance < 0.4  $\Omega$  is suitable. Ferrite core inductors that meet these specifications are available in small, surface-mount packages.

To minimize Electro-Magnetic Interference (EMI), a toroid or pot core type inductor is recommended. Rod core inductors are a lower cost alternative if EMI is not a problem.

# ADP1108

## Calculating the Inductor Value

Selecting the proper inductor value is a simple three-step process:

1. Define the operating parameters: minimum input voltage, maximum input voltage, output voltage and output current.
2. Select the appropriate conversion topology (step-up, step-down or inverting).
3. Calculate the inductor value, using the equations in the following sections.

### Inductor Selection—Step-Up Converter

In a step-up or boost converter (Figure 15), the inductor must store enough power to make up the difference between the input voltage and the output voltage. The inductor power is calculated from the equation:

$$P_L = (V_{OUT} + V_D - V_{IN(MIN)}) \times (I_{OUT}) \quad (\text{Equation 1})$$

where  $V_D$  is the diode forward voltage ( $\approx 0.5$  V for a 1N5818 Schottky). Energy is only stored in the inductor while the ADP1108 switch is ON, so the energy stored in the inductor on each switching cycle must be equal to or greater than:

$$\frac{P_L}{f_{OSC}} \quad (\text{Equation 2})$$

in order for the ADP1108 to regulate the output voltage.

When the internal power switch turns ON, current flow in the inductor increases at the rate of:

$$I_L(t) = \frac{V_{IN}}{R'} \left( 1 - e^{-\frac{R't}{L}} \right) \quad (\text{Equation 3})$$

where  $L$  is in henrys and  $R'$  is the sum of the switch equivalent resistance (typically  $0.8 \Omega$  at  $+25^\circ\text{C}$ ) and the dc resistance of the inductor. If the voltage drop across the switch is small compared to  $V_{IN}$ , a simpler equation can be used:

$$I_L(t) = \frac{V_{IN}}{L} t \quad (\text{Equation 4})$$

Replacing  $t$  in the above equation with the ON time of the ADP1108 ( $36 \mu\text{s}$ , typical) will define the peak current for a given inductor value and input voltage. At this point, the inductor energy can be calculated as follows:

$$E_L = \frac{1}{2} L \times I_{PEAK}^2 \quad (\text{Equation 5})$$

As previously mentioned,  $E_L$  must be greater than  $P_L/f_{OSC}$  so the ADP1108 can deliver the necessary power to the load. For best efficiency, peak current should be limited to 1 A or less. Higher switch currents will reduce efficiency because of increased saturation voltage in the switch. High peak current also increases output ripple. As a general rule, keep peak current as low as possible to minimize losses in the switch, inductor and diode.

In practice, the inductor value is easily selected using the equations above. For example, consider a supply that will generate 12 V at 30 mA from a 3 V battery, assuming a 2 V end-of-life voltage. The inductor power required is from Equation 1:

$$P_L = (12 \text{ V} + 0.5 \text{ V} - 2 \text{ V}) \times (30 \text{ mA}) = 315 \text{ mW}$$

On each switching cycle, the inductor must supply:

$$\frac{P_L}{f_{OSC}} = \frac{315 \text{ mW}}{19 \text{ kHz}} = 16.6 \mu\text{J}$$

The required inductor power is fairly low in this example, so the peak current can also be low. Assuming a peak current of 500 mA as a starting point, Equation 4 can be rearranged to recommend an inductor value:

$$L = \frac{V_{IN}}{I_{L(MAX)}} t = \frac{2 \text{ V}}{500 \text{ mA}} 36 \mu\text{s} = 144 \mu\text{H}$$

Substituting a standard inductor value of 100  $\mu\text{H}$  with  $0.2 \Omega$  dc resistance, will produce a peak switch current of:

$$I_{PEAK} = \frac{2 \text{ V}}{1.0 \Omega} \left( 1 - e^{-\frac{1.0 \Omega \times 36 \mu\text{s}}{100 \mu\text{H}}} \right) = 605 \text{ mA}$$

Once the peak current is known, the inductor energy can be calculated from Equation 5:

$$E_L = \frac{1}{2} \left( 100 \mu\text{H} \times (605 \text{ mA})^2 \right) = 18.3 \mu\text{J}$$

The inductor energy of  $18.3 \mu\text{J}$  is greater than the  $P_L/f_{OSC}$  requirement of  $16.6 \mu\text{J}$ , so the 100  $\mu\text{H}$  inductor will work in this application. By substituting other inductor values into the same equations, the optimum inductor value can be selected. When selecting an inductor, the peak current must not exceed the maximum switch current of 1.5 A. If the calculated peak current is greater than 1.5 A, either the ADP3000 should be considered or an external power transistor can be used.

The peak current must be evaluated for both minimum and maximum values of input voltage. If the switch current is high when  $V_{IN}$  is at its minimum, the 1.5 A limit may be exceeded at the maximum value of  $V_{IN}$ . In this case, the current limit feature of the ADP1108 can be used to limit switch current. Simply select a resistor (using Figure 3) that will limit the maximum switch current to the  $I_{PEAK}$  value calculated for the minimum value of  $V_{IN}$ . This will improve efficiency by producing a constant  $I_{PEAK}$  as  $V_{IN}$  increases. See the Limiting the Switch Current section of this data sheet for more information.

Note that the switch current limit feature does not protect the circuit if the output is shorted to ground. In this case, current is limited only by the dc resistance of the inductor and the forward voltage of the diode.

### Inductor Selection—Step-Down Converter

The step-down mode of operation is shown in Figure 16. Unlike the step-up mode, the ADP1108's power switch does not saturate when operating in the step-down mode. Therefore, switch current should be limited to 650 mA in this mode. If the input voltage will vary over a wide range, the  $I_{LIM}$  pin can be used to limit the maximum switch current. Higher switch current is possible by adding an external switching transistor, as shown in Figure 18.

The first step in selecting the step-down inductor is to calculate the peak switch current as follows:

$$I_{PEAK} = \frac{2 I_{OUT}}{DC} \left( \frac{V_{OUT} + V_D}{V_{IN} - V_{SW} + V_D} \right) \quad (\text{Equation 6})$$



where:  $DC$  = duty cycle (0.7 for the ADP1108)

$V_{SW}$  = voltage drop across the switch

$V_D$  = diode drop (0.5 V for a 1N5818)

$I_{OUT}$  = output current

$V_{OUT}$  = the output voltage

$V_{IN}$  = the minimum input voltage

As previously mentioned, the switch voltage is higher in step-down mode than in step-up mode.  $V_{SW}$  is a function of switch current and is therefore a function of  $V_{IN}$ ,  $L$ , time and  $V_{OUT}$ . For most applications, a  $V_{SW}$  value of 1.5 V is recommended.

The inductor value can now be calculated:

$$L = \frac{V_{IN(MIN)} - V_{SW} - V_{OUT}}{I_{PEAK}} \times t_{ON} \quad (\text{Equation 7})$$

where:  $t_{ON}$  = switch ON time (36  $\mu$ s)

If the input voltage will vary (such as an application that must operate from a 9 V, 12 V or 15 V source), an  $R_{LIM}$  resistor should be selected from Figure 4. The  $R_{LIM}$  resistor will keep switch current constant as the input voltage rises. Note that there are separate  $R_{LIM}$  values for step-up and step-down modes of operation.

For example, assume that +5 V at 250 mA is required from a +9 V to +18 V source. Deriving the peak current from Equation 6 yields:

$$I_{PEAK} = \frac{2 \times 250 \text{ mA}}{0.7} \left( \frac{5 + 0.5}{9 - 1.5 + 0.5} \right) = 491 \text{ mA}$$

The peak current can then be inserted into Equation 7 to calculate the inductor value:

$$L = \frac{9 - 1.5 - 5}{491 \text{ mA}} \times 36 \mu\text{s} = 183 \mu\text{H}$$

Since 183  $\mu$ H is not a standard value, the next lower standard value of 150  $\mu$ H would be specified.

To avoid exceeding the maximum switch current when the input voltage is at +18 V, an  $R_{LIM}$  resistor should be specified. Using Figure 4, a value of 160  $\Omega$  will limit the switch current to 500 mA.

#### Inductor Selection—Positive-to-Negative Converter

The configuration for a positive-to-negative converter using the ADP1108 is shown in Figure 19. As with the step-up converter, all of the output power for the inverting circuit must be supplied by the inductor. The required inductor power is derived from the formula:

$$P_L (|V_{OUT}| + V_D) \times (I_{OUT}) \quad (\text{Equation 8})$$

The ADP1108 power switch does not saturate in positive-to-negative mode. The voltage drop across the switch can be modeled as a 0.75 V base-emitter diode in series with a 0.65  $\Omega$  resistor. When the switch turns on, inductor current will rise at a rate determined by:

$$I_L(t) = \frac{V_L}{R'} \left( 1 - e^{-\frac{R't}{L}} \right) \quad (\text{Equation 9})$$

where:  $R' = 0.65 \Omega + R_L$  (DC)

$$V_L = V_{IN} - 0.75 \text{ V}$$

For example, assume that a -5 V output at 100 mA is to be generated from a +4.5 V to +5.5 V source. The power in the inductor is calculated from Equation 8:

$$P_L = (|-5 \text{ V}| + 0.5 \text{ V}) \times (100 \text{ mA}) = 550 \text{ mW}$$

During each switching cycle, the inductor must supply the following energy:

$$\frac{P_L}{f_{OSC}} = \frac{550 \text{ mW}}{19 \text{ kHz}} = 28.9 \mu\text{J}$$

Using a standard inductor value of 220  $\mu$ H with 0.3  $\Omega$  dc resistance will produce a peak switch current of:

$$I_{PEAK} = \frac{4.5 \text{ V} - 0.75 \text{ V}}{0.65 \Omega + 0.3 \Omega} \left( 1 - e^{-\frac{0.95 \Omega \times 36 \mu\text{s}}{220 \mu\text{H}}} \right) = 568 \text{ mA}$$

Once the peak current is known, the inductor energy can be calculated from Equation 9:

$$E_L = \frac{1}{2} \left( 220 \mu\text{H} \times (568 \text{ mA})^2 \right) = 35.5 \mu\text{J}$$

The inductor energy of 35.5  $\mu$ J is greater than the  $P_L/f_{OSC}$  requirement of 28.9  $\mu$ J, so the 220  $\mu$ H inductor will work in this application.

To avoid exceeding the maximum switch current when the input voltage is at +5.5 V, an  $R_{LIM}$  resistor should be specified. Referring to Figure 4, a value of 150  $\Omega$  is appropriate in this application.

#### Capacitor Selection

For optimum performance, the ADP1108's output capacitor must be carefully selected. Choosing an inappropriate capacitor can result in low efficiency and/or high output ripple.

Ordinary aluminum electrolytic capacitors are inexpensive, but often have poor Equivalent Series Resistance (ESR) and Equivalent Series Inductance (ESL). Low ESR aluminum capacitors, specifically designed for switch mode converter applications, are also available, and these are a better choice than general purpose devices. Even better performance can be achieved with tantalum capacitors, although their cost is higher. Very low values of ESR can be achieved by using OS-CON\* capacitors (Sanyo Corporation, San Diego, CA). These devices are fairly small, available with tape-and-reel packaging, and have very low ESR.

The effects of capacitor selection on output ripple are demonstrated in Figures 12, 13, and 14. These figures show the output of the same ADP1108 converter, which was evaluated with three different output capacitors. In each case, the peak switch current is 500 mA and the capacitor value is 100  $\mu$ F. Figure 12 shows a Panasonic HF-series\* radial aluminum electrolytic. When the switch turns off, the output voltage jumps by about 90 mV and then decays as the inductor discharges into the capacitor. The rise in voltage indicates an ESR of about 0.18  $\Omega$ . In Figure 13, the aluminum electrolytic has been replaced by a Sprague 593D-series\* tantalum device. In this case the output jumps about 35 mV, which indicates an ESR of 0.07  $\Omega$ . Figure 14 shows an OS-CON SA series capacitor in the same circuit, and ESR is only 0.02  $\Omega$ .

\*All trademarks are the property of their respective holders.

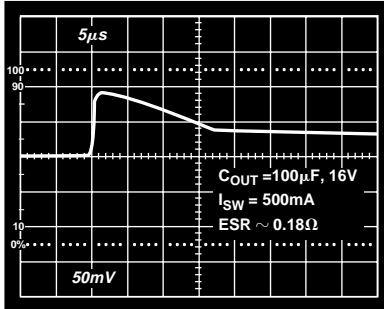

Figure 12. Aluminum Electrolytic

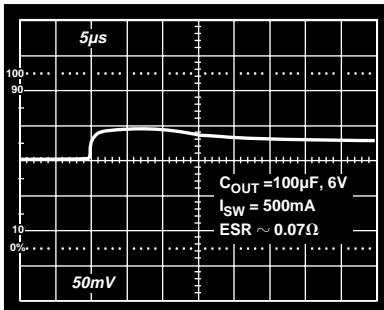

Figure 13. Tantalum Electrolytic

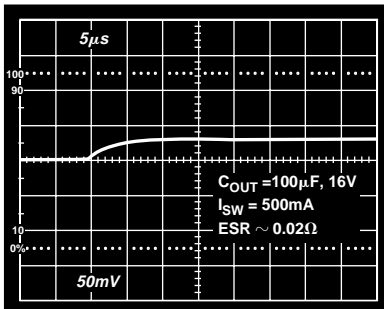

Figure 14. OS-CON Capacitor

If low output ripple is important, the user should consider using the ADP3000. This device switches at 400 kHz, which simplifies the design of the output filter. Consult the ADP3000 data sheet for additional details.

## DIODE SELECTION

In specifying a diode, consideration must be given to speed, forward voltage drop and reverse leakage current. When the ADP1108 switch turns off, the diode must turn on rapidly if high efficiency is to be maintained. Schottky rectifiers, as well as fast signal diodes such as the 1N4148, are appropriate. The forward voltage of the diode represents power that is not delivered to the load, so  $V_F$  must also be minimized. Again, Schottky diodes are recommended. Leakage current is especially important in low-current applications, where the leakage can be a significant percentage of the total quiescent current.

For most circuits, the 1N5818 is a suitable companion to the ADP1108. This diode has a  $V_F$  of 0.5 V at 1 A, 4  $\mu$ A to 10  $\mu$ A leakage and fast turn-on and turn-off times. A surface mount version, the MBR5130T3, is also available.

For switch currents of 100 mA or less, a Schottky diode such as the BAT85 provides a  $V_F$  of 0.8 V at 100 mA and leakage

less than 1  $\mu$ A. A similar device, the BAT54, is available in an SOT-23 package. Even lower leakage, in the 1 nA to 5 nA range, can be obtained with a 1N4148 signal diode.

General purpose rectifiers, such as the 1N4001, are not suitable for ADP1108 circuits. These devices, which have turn-on times of 10  $\mu$ s or more, are far too slow for switching power supply applications. Using such a diode “just to get started” will result in wasted time and effort. Even if an ADP1108 circuit appears to function with a 1N4001, the resulting performance will not be indicative of the circuit performance when the correct diode is used.

## Circuit Operation, Step-Up (Boost) Mode

In boost mode, the ADP1108 produces an output voltage higher than the input voltage. For example, +12 V can be generated from a +5 V logic power supply or +5 V can be derived from two alkaline cells (+3 V).

Figure 15 shows an ADP1108 configured for step-up operation. The collector of the internal power switch is connected to the output side of the inductor, while the emitter is connected to GND. When the switch turns on, Pin SW1 is pulled near ground. This action forces a voltage across L1 equal to  $V_{IN} - V_{CE(SAT)}$ , and current begins to flow through L1. This current reaches a final value (ignoring second-order effects) of:

$$I_{PEAK} \cong \frac{V_{IN} - V_{CE(SAT)}}{L} \times 36 \mu s$$

where 36  $\mu$ s is the ADP1108 switch’s “on” time.

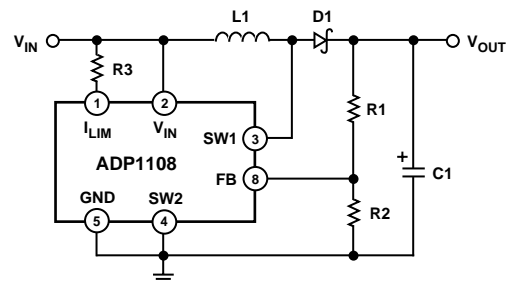

Figure 15. Step-Up Mode Operation

When the switch turns off, the magnetic field collapses. The polarity across the inductor changes, current begins to flow through D1 into the load and the output voltage is driven above the input voltage.

The output voltage is fed back to the ADP1108 via resistors R1 and R2. When the voltage at Pin FB falls below 1.245 V, SW1 turns “on” again and the cycle repeats. The output voltage is therefore set by the formula:

$$V_{OUT} = 1.245 V \times \left( 1 + \frac{R1}{R2} \right)$$

The circuit of Figure 15 shows a direct current path from  $V_{IN}$  to  $V_{OUT}$ , via the inductor and D1. Therefore, the boost converter is not protected if the output is short circuited to ground.

## Circuit Operation, Step-Down (Buck) Mode

The ADP1108’s step-down mode is used to produce an output voltage lower than the input voltage. For example, the output of four NiCd cells (+4.8 V) can be converted to a +3 V logic supply.

A typical configuration for step-down operation of the ADP1108 is shown in Figure 16. In this case, the collector of the internal power switch is connected to  $V_{IN}$  and the emitter drives the inductor.



When the switch turns on, SW2 is pulled up toward  $V_{IN}$ . This forces a voltage across L1 equal to  $(V_{IN} - V_{CE}) - V_{OUT}$ , and causes current to flow in L1. This current reaches a final value of:

$$I_{PEAK} \cong \frac{V_{IN} - V_{CE} - V_{OUT}}{L} \times 36 \mu s$$

where 36  $\mu s$  is the ADP1108 switch's "on" time.

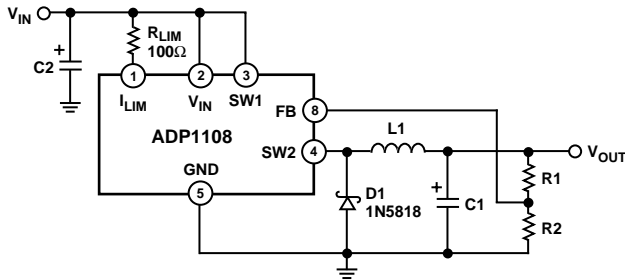

Figure 16. Step-Down Mode Operation

When the switch turns off, the magnetic field collapses. The polarity across the inductor changes and the switch side of the inductor is driven below ground. Schottky diode D1 then turns on and current flows into the load. Notice that the Absolute Maximum Rating for the ADP1108's SW2 pin is 0.5 V below ground. To avoid exceeding this limit, D1 must be a Schottky diode. If a silicon diode is used for D1, Pin SW2 can go to -0.8 V, which will cause potentially damaging power dissipation within the ADP1108.

The output voltage of the buck regulator is fed back to the ADP1108's FB pin by resistors R1 and R2. When the voltage at Pin FB falls below 1.245 V, the internal power switch turns "on" again and the cycle repeats. The output voltage is set by the formula:

$$V_{OUT} = 1.245 V \times \left(1 + \frac{R1}{R2}\right)$$

When operating the ADP1108 in step-down mode, the output voltage is impressed across the internal power switch's emitter-base junction while the switch is off. To protect the switch, the output voltage should be limited to 6.2 V or less. If a higher output voltage is required, a Schottky diode should be placed in series with SW2, as shown in Figure 17.

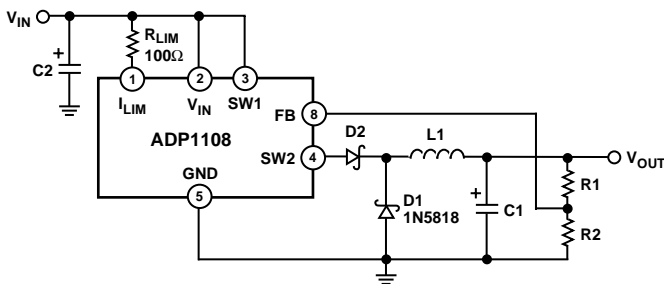

Figure 17. Step-Down Model,  $V_{OUT} > 6.2 V$

If the input voltage to the ADP1108 varies over a wide range, a current limiting resistor at Pin 1 may be required. If a particular circuit requires high peak inductor current with minimum input supply voltage, then the peak current may exceed the switch maximum rating and/or saturate the inductor when the supply voltage is at the maximum value. See the Limiting the Switch Current section of this data sheet for specific recommendations.

REV. 0

### Increasing Output Current in the Step-Down Regulator

Unlike the boost configuration, the ADP1108's internal power switch is not saturated when operating in step-down mode. A conservative value for the voltage across the switch in step-down mode is 1.5 V. This results in high power dissipation within the ADP1108 when high peak current is required. To increase the output current, an external PNP switch can be added (Figure 18). In this circuit, the ADP1108 provides base drive to Q1 through R3 while R4 ensures that Q1 turns off rapidly. The ADP1108's internal current limiting function will not work in this circuit, R5 is provided for this purpose. With the value shown, R5 limits current to 2 A. In addition to reducing power dissipation on the ADP1108, this circuit also reduces the switch voltage. When selecting an inductor value for the circuit of Figure 18, the switch voltage can be calculated from the formula:

$$V_{SW} = V_{R5} + V_{Q1(SAT)} \cong 0.6 V + 0.4 V \cong 1 V$$

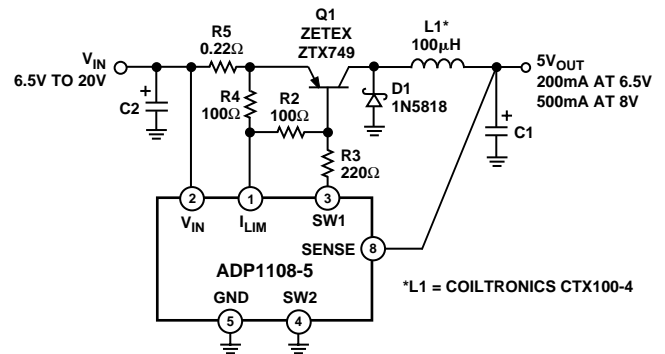

Figure 18. High Current Step-Down Operation

### Positive-to-Negative Conversion

The ADP1108 can convert a positive input voltage to a negative output voltage, as shown in Figure 19. This circuit is essentially identical to the step-down application of Figure 16, except that the "output" side of the inductor is connected to power ground. When the ADP1108's internal power switch turns off, current flowing in the inductor forces the output ( $-V_{OUT}$ ) to a negative potential. The ADP1108 will continue to turn the switch on until its FB pin is 1.245 V above its GND pin, so the output voltage is determined by the formula:

$$V_{OUT} = 1.245 V \times \left(1 + \frac{R1}{R2}\right)$$

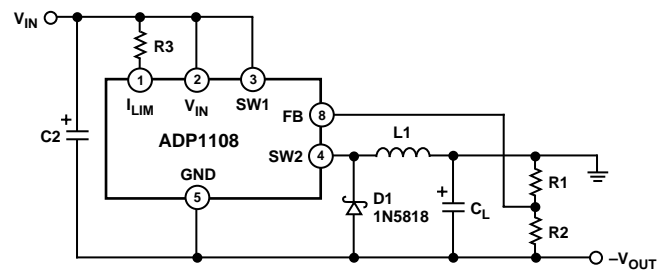

Figure 19. A Positive-to-Negative Converter

The design criteria for the step-down application also apply to the positive-to-negative converter. The output voltage should be limited to  $|6.2 V|$ , unless a diode is inserted in series with the SW2 pin (see Figure 17). Also, D1 must again be a Schottky diode to prevent excessive power dissipation in the ADP1108.

# ADP1108

## Negative-to-Positive Conversion

The circuit of Figure 20 converts a negative input voltage to a positive output voltage. Operation of this circuit configuration is similar to the step-up topology of Figure 15, except that the current through feedback resistor R1 is level-shifted below ground by a PNP transistor. The voltage across R1 is  $(V_{OUT} - V_{BEQ1})$ . However, diode D2 level-shifts the base of Q1 about 0.6 V below ground, thereby cancelling the  $V_{BE}$  of Q1. The addition of D2 also reduces the circuit's output voltage sensitivity to temperature, which would otherwise be dominated by the  $-2 \text{ mV}/^\circ\text{C}$   $V_{BE}$  contribution of Q1. The output voltage for this circuit is determined by the formula:

$$V_{OUT} = 1.245 V \times \left( \frac{R1}{R2} \right)$$

Unlike the positive step-up converter, the negative-to-positive converter's output voltage can be either higher or lower than the input voltage.

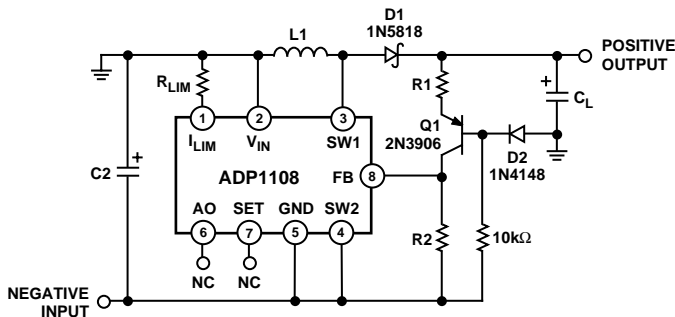

Figure 20. A Negative-to-Positive Converter

## Limiting the Switch Current

The ADP1108's  $R_{LIM}$  pin permits the switch current to be limited with a single resistor. This current limiting action occurs on a pulse by pulse basis. This feature allows the input voltage to vary over a wide range, without saturating the inductor or exceeding the maximum switch rating. For example, a particular design may require peak switch current of 800 mA with a 2.0 V input. If  $V_{IN}$  rises to 4 V, however, the switch current will exceed 1.6 A. The ADP1108 limits switch current to 1.5 A and thereby protects the switch, but the output ripple will increase. Selecting the proper resistor will limit the switch current to 800 mA, even if  $V_{IN}$  increases. The relationship between  $R_{LIM}$  and maximum switch current is shown in Figures 3 and 4.

The  $I_{LIM}$  feature is also valuable for controlling inductor current when the ADP1108 goes into continuous-conduction mode. This occurs in the step-up mode when the following condition is met:

$$\frac{V_{OUT} + V_{DIODE}}{V_{IN} - V_{SW}} < \frac{1}{1 - DC}$$

where DC is the ADP1108's duty cycle. When this relationship exists, the inductor current does not go all the way to zero during the time that the switch is OFF. When the switch turns on for the next cycle, the inductor current begins to ramp up from the residual level. If the switch ON time remains constant, the inductor current will increase to a high level (see Figure 21). This increases output ripple and can require a larger inductor and capacitor. By controlling switch current with the  $I_{LIM}$  resistor, output ripple current can be maintained at the design values. Figure 22 illustrates the action of the  $I_{LIM}$  circuit.

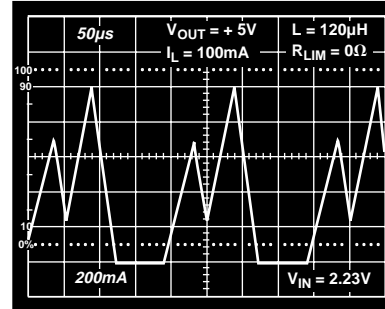

Figure 21. ( $I_{LIM}$  Operation,  $R_{LIM} = 0 \Omega$ )

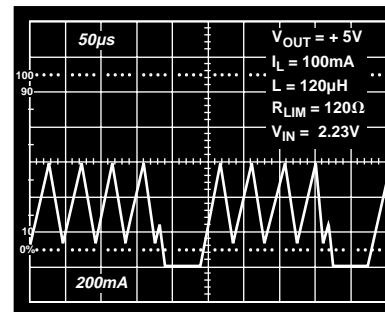

Figure 22. ( $I_{LIM}$  Operation,  $R_{LIM} = 120 \Omega$ )

The internal structure of the  $I_{LIM}$  circuit is shown in Figure 23. Q1 is the ADP1108's internal power switch, which is paralleled by sense transistor Q2. The relative sizes of Q1 and Q2 are scaled so that  $I_{Q2}$  is 0.5% of  $I_{Q1}$ . Current flows to Q2 through an internal  $80 \Omega$  resistor and through the  $R_{LIM}$  resistor. These two resistors parallel the base-emitter junction of the oscillator-disable transistor, Q3. When the voltage across R1 and  $R_{LIM}$  exceeds 0.6 V, Q3 turns on and terminates the output pulse. If only the  $80 \Omega$  internal resistor is used (i.e. the  $I_{LIM}$  pin is connected directly to  $V_{IN}$ ), the maximum switch current will be 1.5 A.

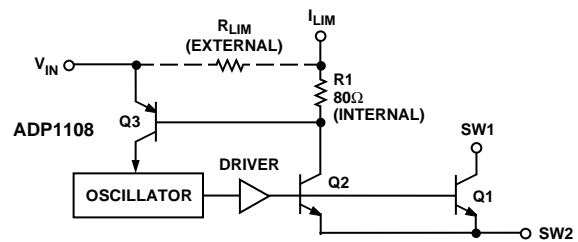

Figure 23. ADP1108 Current Limit Operation

The delay through the current limiting circuit is approximately  $2 \mu\text{s}$ . If the switch ON time is reduced to less than  $5 \mu\text{s}$ , accuracy of the current trip-point is reduced. Attempting to program a switch ON time of  $2 \mu\text{s}$  or less will produce spurious responses in the switch ON time. However, the ADP1108 will still provide a properly regulated output voltage.

## PROGRAMMING THE GAIN BLOCK

The gain block of the ADP1108 can be used as a low battery detector, error amplifier or linear post regulator. The gain block consists of an op amp with PNP inputs and an open-collector NPN output. The inverting input is internally connected to the ADP1108's 1.245 V reference, while the noninverting input is available at the SET Pin. The NPN output transistor will sink about 300  $\mu$ A.

Figure 24a shows the gain block configured as a low-battery monitor. Resistors R1 and R2 should be set to high values to reduce quiescent current, but not so high that bias current in the SET input causes large errors. A value of 33 k $\Omega$  for R2 is a good compromise.

The value for R1 is then calculated from the formula:

$$R1 = \frac{V_{LOBATT} - 1.245 V}{\left(\frac{1.245 V}{R2}\right)}$$

where  $V_{LOBATT}$  is the desired low battery trip point. Since the gain block output is an open-collector NPN, a pull-up resistor should be connected to the positive logic power supply.

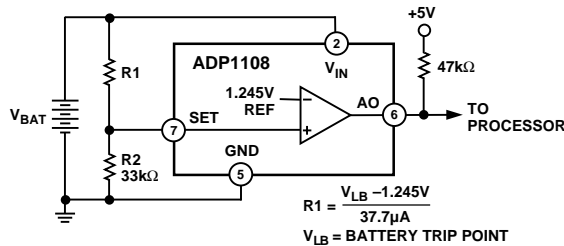

Figure 24a. Setting the Low Battery Detector Trip Point

The circuit of Figure 24a may produce multiple pulses when approaching the trip point, due to noise coupled into the SET input. To prevent multiple interrupts to the digital logic, hysteresis can be added to the circuit (Figure 24b). Resistor R3, with a value of 1 M $\Omega$  to 10 M $\Omega$ , provides the hysteresis. The addition of R3 will change the trip point slightly, so the new value for R1 will be:

$$R1 = \frac{V_{LOBATT} - 1.245 V}{\left(\frac{1.245 V}{R2}\right) - \left(\frac{V_L - 1.245 V}{R_L + R3}\right)}$$

where  $V_L$  is the logic power supply voltage,  $R_L$  is the pull-up resistor and R3 creates the hysteresis.

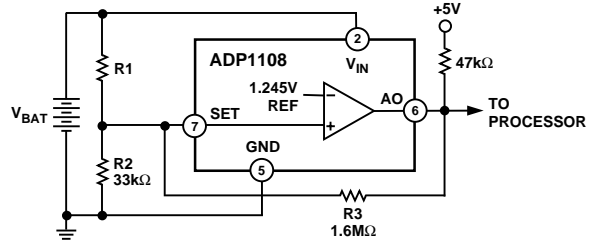

Figure 24b. Adding Hysteresis to the Low Battery Detector

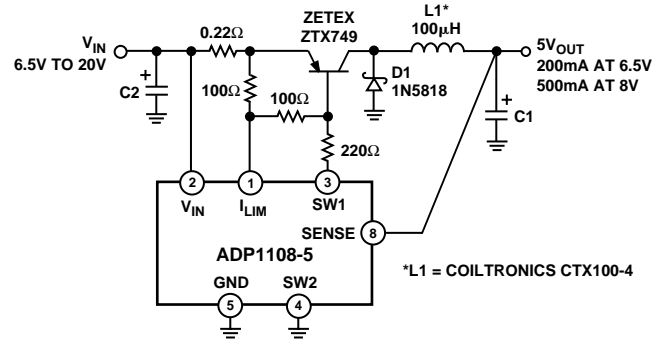

Figure 25. 6.5 V to 5 V Step-Down Converter

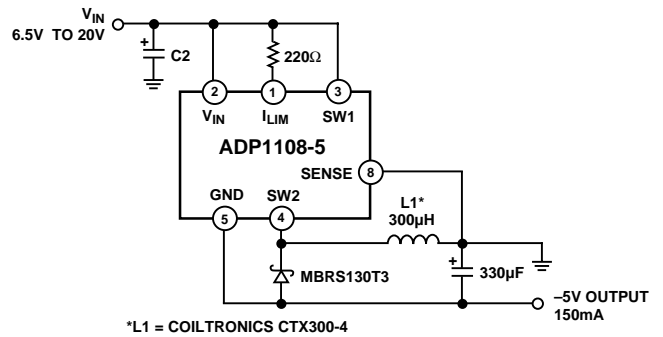
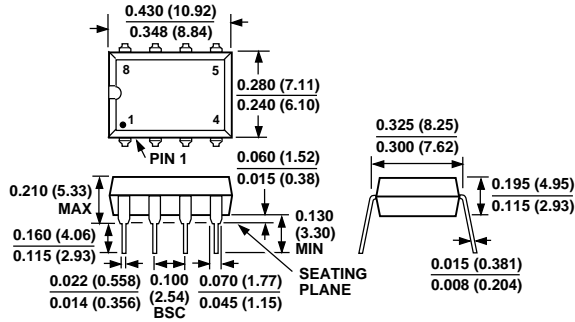

Figure 26. Positive to -5 V Converter

**OUTLINE DIMENSIONS**  
 Dimensions shown in inches and (mm).

**8-Lead Plastic DIP  
 (N-8)**



**8-Lead SOIC  
 (SO-8)**

