



# BTA/BTB10 Series

SNUBBERLESS™ & STANDARD

10A TRIACs

## MAIN FEATURES:

Symbol	Value	Unit
$I_{T(RMS)}$	10	A
$V_{DRM}/V_{RRM}$	600 and 800	V
$I_{GT}(Q_1)$	25 to 50	mA

## DESCRIPTION

Available either in standard or snubberless version, the BTA/BTB10 triac series is suitable for general purpose AC switching. They can be used as an ON/OFF function in applications such as static relays, heating regulation, induction motor starting circuits... or for phase control operation in light dimmers, motor speed controllers, ...

The snubberless version (W suffix) is specially recommended for use on inductive loads, thanks to their high commutation performances.

By using an internal ceramic pad, the BTA series provides voltage insulated tab (rated at 2500 V RMS) complying with UL standards (File ref.: E81734).

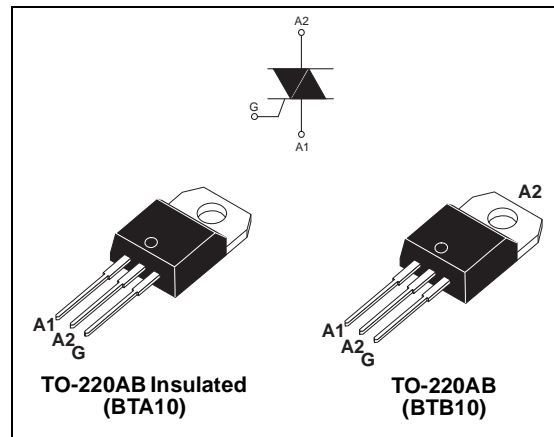

## ABSOLUTE MAXIMUM RATINGS

Symbol	Parameter		Value	Unit	
$I_{T(RMS)}$	RMS on-state current (full sine wave)	TO-220AB	$T_c = 105^\circ\text{C}$	10	A
		TO-220AB Ins.	$T_c = 95^\circ\text{C}$		
$I_{TSM}$	Non repetitive surge peak on-state current (full cycle, $T_j$ initial = $25^\circ\text{C}$ )	F = 60 Hz	t = 16.7 ms	105	A
		F = 50 Hz	t = 20 ms	100	
$I^2t$	$I^2t$ Value for fusing	tp = 10 ms		55	$\text{A}^2\text{s}$
di/dt	Critical rate of rise of on-state current $I_G = 2 \times I_{GT}$ , tr ≤ 100 ns	F = 120 Hz	$T_j = 125^\circ\text{C}$	50	$\text{A}/\mu\text{s}$
$V_{DSM}/V_{RSM}$	Non repetitive surge peak off-state voltage	tp = 10 ms	$T_j = 25^\circ\text{C}$	$V_{DRM}/V_{RRM} + 100$	V
$I_{GM}$	Peak gate current	tp = 20 μs	$T_j = 125^\circ\text{C}$	4	A
$P_{G(AV)}$	Average gate power dissipation	$T_j = 125^\circ\text{C}$		1	W
$T_{stg}$ $T_j$	Storage junction temperature range Operating junction temperature range			- 40 to + 150 - 40 to + 125	$^\circ\text{C}$

## BTA/BTB10 Series

### ELECTRICAL CHARACTERISTICS (T<sub>j</sub> = 25°C, unless otherwise specified)

#### ■ SNUBBERLESS™ (3 Quadrants)

Symbol	Test Conditions	Quadrant		BTA/BTB10		Unit
				CW	BW	
I <sub>GT</sub> (1)	V <sub>D</sub> = 12 V    R <sub>L</sub> = 33 Ω	I - II - III	MAX.	35	50	mA
V <sub>GT</sub>		I - II - III	MAX.	1.3		V
V <sub>GD</sub>	V <sub>D</sub> = V <sub>DRM</sub> R <sub>L</sub> = 3.3 kΩ    T <sub>j</sub> = 125°C	I - II - III	MIN.	0.2		V
I <sub>H</sub> (2)	I <sub>T</sub> = 500 mA		MAX.	35	50	mA
I <sub>L</sub>	I <sub>G</sub> = 1.2 I <sub>GT</sub>	I - III	MAX.	50	70	mA
		II		60	80	
dV/dt (2)	V <sub>D</sub> = 67 % V <sub>DRM</sub> gate open    T <sub>j</sub> = 125°C		MIN.	500	1000	V/μs
(dI/dt) <sub>c</sub> (2)	Without snubber    T <sub>j</sub> = 125°C		MIN.	5.5	9.0	A/ms

#### ■ STANDARD (4 Quadrants)

Symbol	Test Conditions	Quadrant		BTA/BTB10		Unit
				C	B	
I <sub>GT</sub> (1)	V <sub>D</sub> = 12 V    R <sub>L</sub> = 33 Ω	I - II - III IV	MAX.	25 50	50 100	mA
V <sub>GT</sub>		ALL	MAX.	1.3		V
V <sub>GD</sub>	V <sub>D</sub> = V <sub>DRM</sub> R <sub>L</sub> = 3.3 kΩ    T <sub>j</sub> = 125°C	ALL	MIN.	0.2		V
I <sub>H</sub> (2)	I <sub>T</sub> = 500 mA		MAX.	25	50	mA
I <sub>L</sub>	I <sub>G</sub> = 1.2 I <sub>GT</sub>	I - III - IV	MAX.	40	50	mA
		II		80	100	
dV/dt (2)	V <sub>D</sub> = 67 % V <sub>DRM</sub> gate open    T <sub>j</sub> = 125°C		MIN.	200	400	V/μs
(dV/dt) <sub>c</sub> (2)	(dI/dt) <sub>c</sub> = 4.4 A/ms    T <sub>j</sub> = 125°C		MIN.	5	10	V/μs

### STATIC CHARACTERISTICS

Symbol	Test Conditions			Value	Unit
V <sub>TM</sub> (2)	I <sub>TM</sub> = 14 A    t <sub>p</sub> = 380 μs	T <sub>j</sub> = 25°C	MAX.	1.55	V
V <sub>to</sub> (2)	Threshold voltage	T <sub>j</sub> = 125°C	MAX.	0.85	V
R <sub>d</sub> (2)	Dynamic resistance	T <sub>j</sub> = 125°C	MAX.	40	mΩ
I <sub>DRM</sub> I <sub>RRM</sub>	V <sub>DRM</sub> = V <sub>RRM</sub>	T <sub>j</sub> = 25°C	MAX.	5	μA
		T <sub>j</sub> = 125°C		1	mA

**Note 1:** minimum IGT is guaranteed at 5% of IGT max.

**Note 2:** for both polarities of A2 referenced to A1

**THERMAL RESISTANCES**

Symbol	Parameter	Value	Unit	
R <sub>th(j-c)</sub>	Junction to case (AC)	TO-220AB	1.5	°C/W
		TO-220AB Insulated	2.4	
R <sub>th(j-a)</sub>	Junction to ambient	TO-220AB	60	°C/W
		TO-220AB Insulated		

**PRODUCT SELECTOR**

Part Number	Voltage (xxx)		Sensitivity	Type	Package
	600 V	800 V			
BTA/BTB10-xxxB	X	X	50 mA	Standard	TO-220AB
BTA/BTB10-xxxBW	X	X	50 mA	Snubberless	TO-220AB
BTA/BTB10-xxxC	X	X	25 mA	Standard	TO-220AB
BTA/BTB10-xxxCW	X	X	35 mA	Snubberless	TO-220AB

BTB: Non insulated TO-220AB package

**ORDERING INFORMATION**

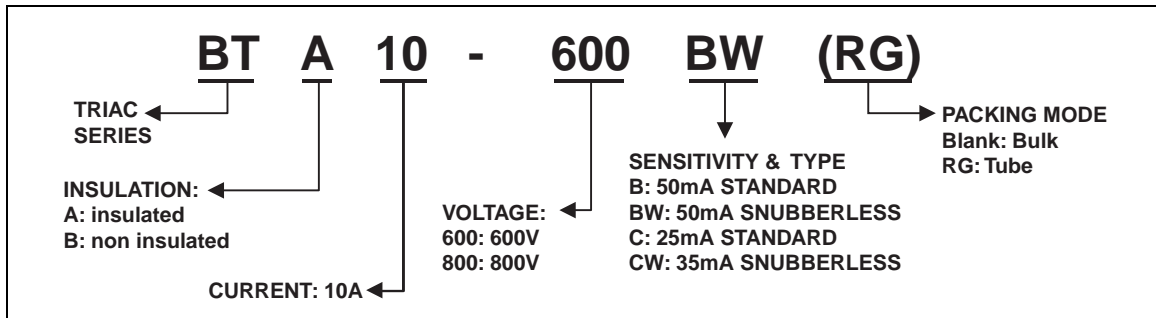

**OTHER INFORMATION**

Part Number	Marking	Weight	Base quantity	Packing mode
BTA/BTB10-xxxzy	BTA/BTB10xxxzy	2.3 g	250	Bulk
BTA/BTB10-xxxzyRG	BTA/BTB10-xxxzy	2.3 g	50	Tube

**Note:** xxx = voltage, y = sensitivity, z = type



**Fig. 1:** Maximum power dissipation versus RMS on-state current (full cycle).

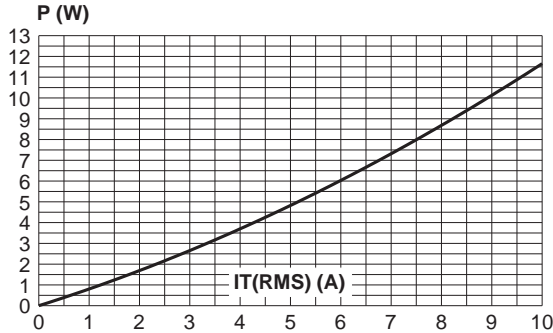

**Fig. 2:** RMS on-state current versus case temperature (full cycle).

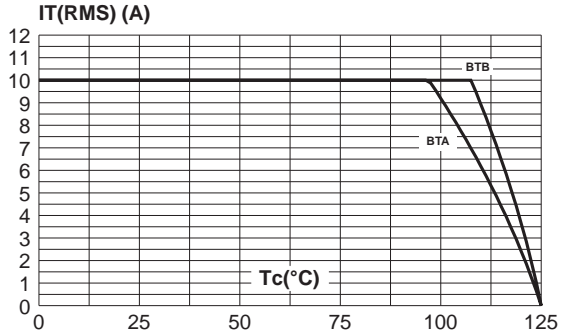

**Fig. 3:** Relative variation of thermal impedance versus pulse duration.

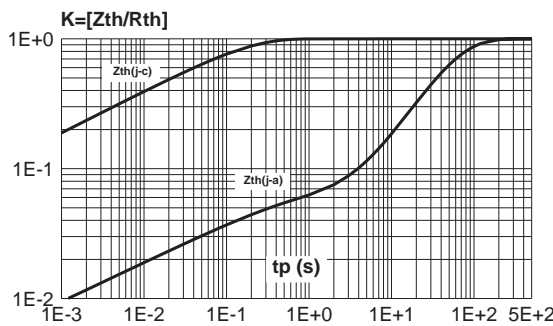

**Fig. 4:** On-state characteristics (maximum values).

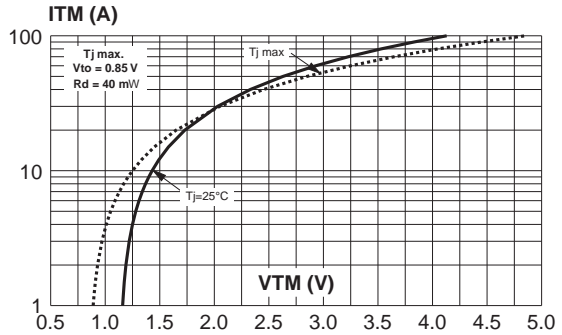

**Fig. 5:** Surge peak on-state current versus number of cycles.

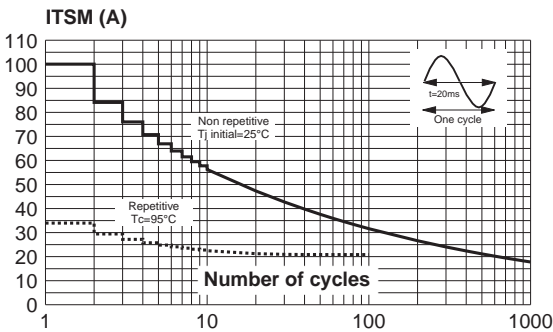

**Fig. 6:** Non-repetitive surge peak on-state current for a sinusoidal pulse with width  $tp < 10ms$ , and corresponding value of  $I^2t$ .

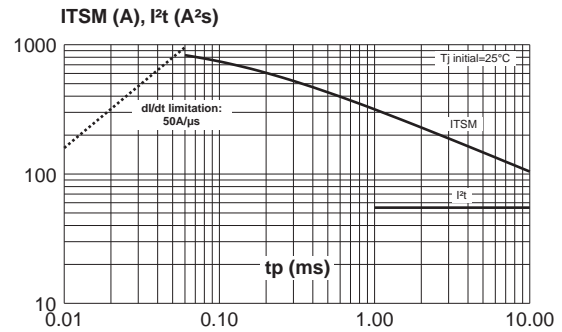

**Fig. 7:** Relative variation of gate trigger current, holding current and latching current versus junction temperature (typical values).

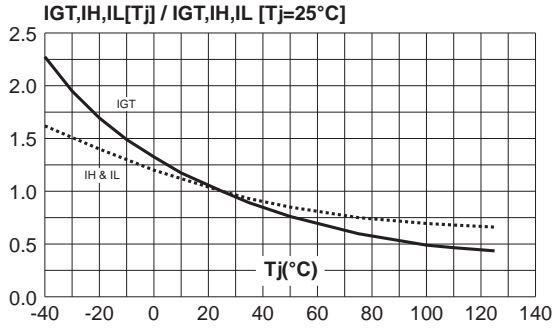

**Fig. 8:** Relative variation of critical rate of decrease of main current versus (dV/dt)c (typical values).

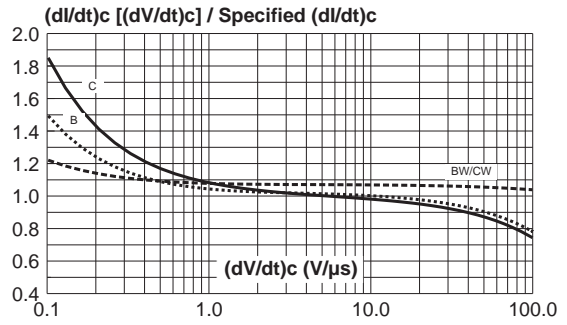

**Fig. 9:** Relative variation of critical rate of decrease of main current versus junction temperature.

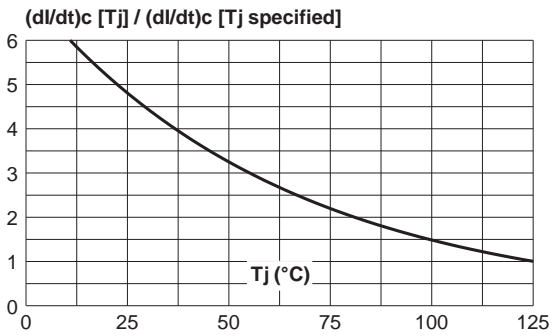

## BTA/BTB10 Series

### PACKAGE MECHANICAL DATA

TO-220AB (Plastic)

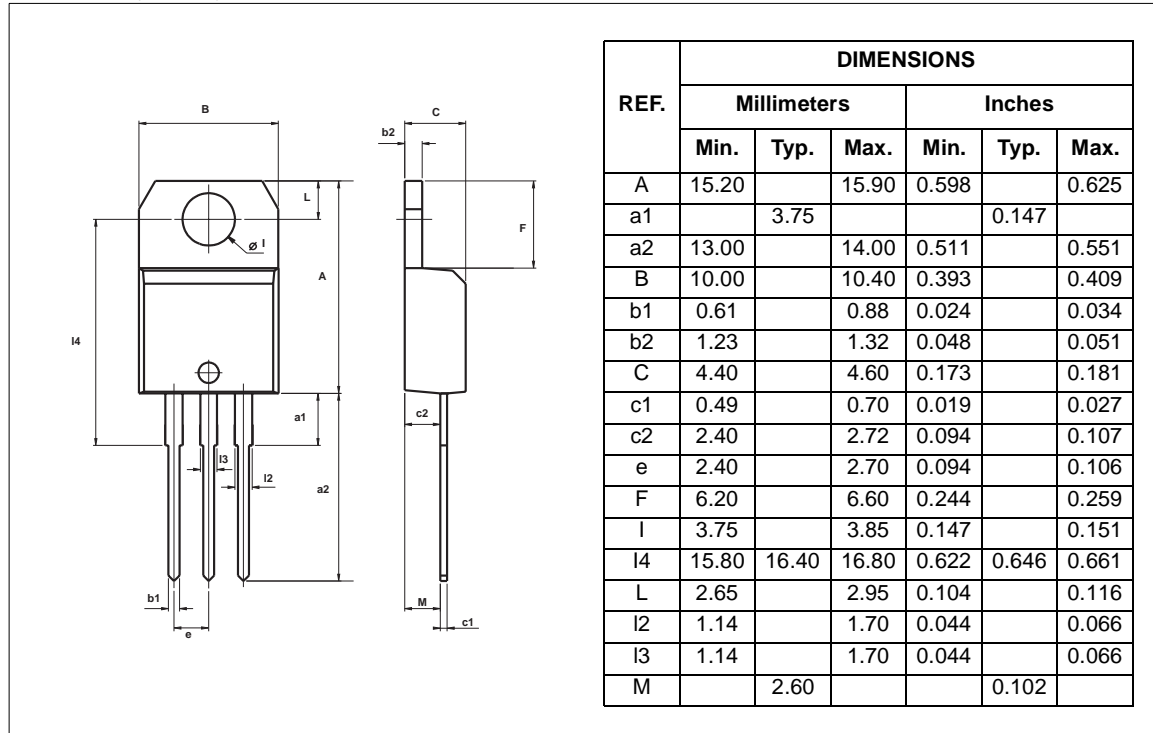

Information furnished is believed to be accurate and reliable. However, STMicroelectronics assumes no responsibility for the consequences of use of such information nor for any infringement of patents or other rights of third parties which may result from its use. No license is granted by implication or otherwise under any patent or patent rights of STMicroelectronics. Specifications mentioned in this publication are subject to change without notice. This publication supersedes and replaces all information previously supplied. STMicroelectronics products are not authorized for use as critical components in life support devices or systems without express written approval of STMicroelectronics.

© The ST logo is a registered trademark of STMicroelectronics

© 2002 STMicroelectronics - Printed in Italy - All Rights Reserved

STMicroelectronics GROUP OF COMPANIES  
 Australia - Brazil - Canada - China - Finland - France - Germany  
 Hong Kong - India - Israel - Italy - Japan - Malaysia - Malta - Morocco - Singapore  
 Spain - Sweden - Switzerland - United Kingdom - United States.

<http://www.st.com>