

FAN5611/FAN5612/FAN5613/FAN5614

Low-Dropout LED Drivers for White, Blue or any Color LED

Features

- LED Drivers for parallel-connected LEDs
- Ultra-low voltage drop (< 300mV) to support direct Li-ion applications
- No EMI, no switching noise
- No external components needed for current matching
- Both analog and PWM brightness control
- FAN5611, FAN5613 feature up to 160mA bias current (up to 40mA for each LED)
- FAN5612 features up to 120mA bias current (up to 40mA for each LED)
- FAN5614 features up to 160mA bias current (up to 80mA for each LED)
- Enable/Shutdown control (FAN5612, FAN5613, FAN5614)
- Shutdown current < 1µA
- Small footprint SC-70 and 2x2 MLP

Applications

- Cell Phones
- PDA, DSC, MP3 Players
- Handheld Computers
- LCD Display Modules
- Keyboard Backlight
- LED Displays

General Description

The FAN5611/FAN5612/FAN5613/FAN5614 driver family provides matched current source bias for white, blue or any color LEDs. The current in the LEDs can be programmed by an external resistor. The individual LED currents are $200 \times I_{SET}$, where I_{SET} is the current through the external resistor connected to the CTRL pin. The FAN5611 and the FAN5613 are capable of driving four LEDs, while the FAN5612 can drive three LEDs. The FAN5614 is designated to drive two high current LEDs. In any case, at least I1 should be always connected to an LED in order to have the other LEDs driven with a matched current to I1.

The FAN5612, FAN5613 and FAN5614 have Enable pin. When these devices are disabled, the supply current drops to less than 1µA.

The FAN5611, FAN5612 and FAN5614 drivers are available in a 6-lead SC-70 package. The FAN5613 is available in an 8-lead MLP package.

Typical Applications

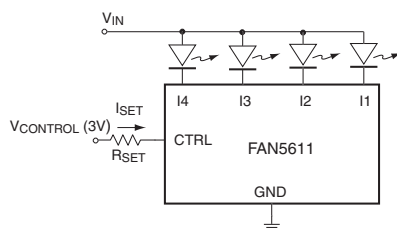

Four Diode Control

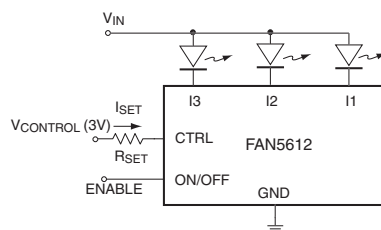

Three Diode Control with ON/OFF

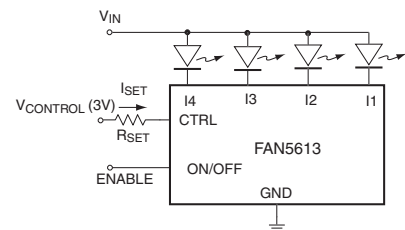

Four Diode Control With ON/OFF

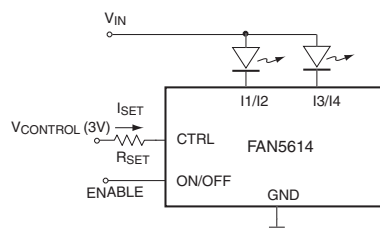

Two Diode Control with ON/OFF

Pin Assignments

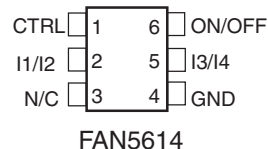
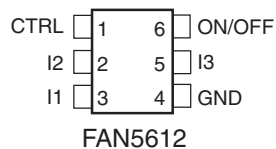
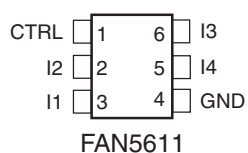

6-LEAD SC-70 PACKAGE

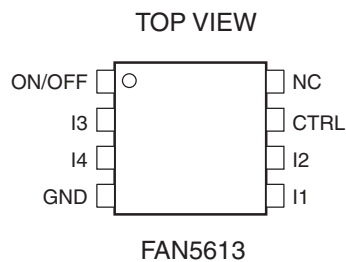

2x2mm 8-LEAD MLP PACKAGE

Pin Description (6-Lead SC-70 and 8-Lead MLP)

Pin No.	Pin Name				Description
	FAN5611	FAN5612	FAN5613	FAN5614	
1	CTRL	CTRL		CTRL	Sets LED Current
			ON/OFF		Chip ON/OFF/Disable
2	I2	I2			Connect to Cathode of LED
			I3		Connect to Cathode of LED
3	I1	I1		I1/I2	Connect to Cathode of LED
			I4		Connect to Cathode of LED
				N/C	No Connection
4	GND	GND	GND	GND	Ground
5	I4				Connect to Cathode of LED
		I3			Connect to Cathode of LED
			I1		Connect to Cathode of LED
				I3/I4	Connect to Cathode of LED
6	I3				Connect to Cathode of LED
		ON/OFF		ON/OFF	Chip ON/OFF/Disable
			I2		Connect to Cathode of LED
7			CTRL		Sets LED Current
8			NC		No Connection

Absolute Maximum Ratings (Note1)

Parameter		Min	Max	Unit
V _{I1} , V _{I2} , V _{I3} , V _{I4} and ENABLE Voltage to GND		-0.3	6	V
CTRL Voltage to GND		-0.3	3	
Power Dissipated by package at T _A = 85°C	6 Lead-SC70		190	mW
	8 Lead-MLP2X2		700	
I ₁ , I ₂ , I ₃ , I ₄ Steady State Current	FAN5611/12/13		40	mA
I ₁ /I ₂ , I ₃ /I ₄ Steady State Current	FAN5614		80	
Lead Temperature (Soldering 10 seconds)			300	°C
Junction Temperature			150	°C
Storage Temperature		-55	150	°C
Electrostatic Discharge Protection (ESD) Level (Note2)	HBM	4		kV
	CDM	1		

Recommended Operating Conditions

Parameter		Min	Typ	Max	Unit
LED Cathode Voltage	FAN5611, FAN5612, FAN5613	0.3	0.5	1	V
	FAN5614	0.15			
Ambient Temperature		-40	25	85	°C

Notes:

- Functional operation under these conditions is NOT implied. Performance and reliability are guaranteed only if Operating Conditions are not exceeded.
- Using Mil Std. 883E, method 3015.7(Human Body Model) and EIA/JESD22C101-A (Charge Device Model)

DC Electrical Characteristics ($V_{IN} = 3.3V$ to $5.5V$, $ENABLE = V_{IN}$, $T_A = 25^\circ C$ Unless otherwise noted)

Parameter		Conditions	Min.	Typ.	Max.	Units
Output Current Multiplication Ratio	FAN5611/12/13	$I_{SET} = 100\mu A$ $V_{SAT} = 300mV$	140	200	260	
	FAN5614	$I_{SET} = 100\mu A$ $V_{SAT} = 150mV$				
LED Current (Per Diode)	FAN5611/12/13	$V_{SAT} = 300mV$ $I_{SET} = 100\mu A$		20		mA
	FAN5614	$V_{SAT} = 150mV$ $I_{SET} = 100\mu A$				
LED to LED Current Matching	FAN5611/12/13	$V_{SAT} = 300mV$ $I_{SET} = 100\mu A$ $T_A = -40^\circ C$ to $85^\circ C$	-3		3	%
	FAN5614	$V_{SAT} = 150mV$ $I_{SET} = 100\mu A$ $T_A = -40^\circ C$ to $85^\circ C$				
Peak Efficiency		$V_{IN} = 3V$		90		%
Current in OFF Mode (I_{SET} and I_I)		$V_{EN} = 0V$			1	μA
Min. ENABLE "ON Voltage" (Note3) (FAN5612, FAN5613, FAN5614)		$I_{SET} = 150\mu A$			3	V
Max. ENABLE "OFF Voltage" (Note3) (FAN5612, FAN5613 FAN5614)			0.5			V

Notes:

3. ENABLE "ON" is V_{EN} for which $I_{I1} > 20mA$ @ $V_{I1} = 0.3V$, while ENABLE "OFF" is V_{EN} for which $I_{I1} < 1\mu A$ @ $V_{I1} > 0.3V$

Typical Performance Characteristics

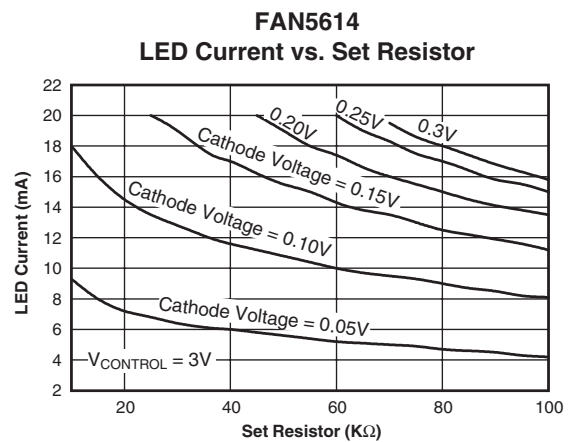
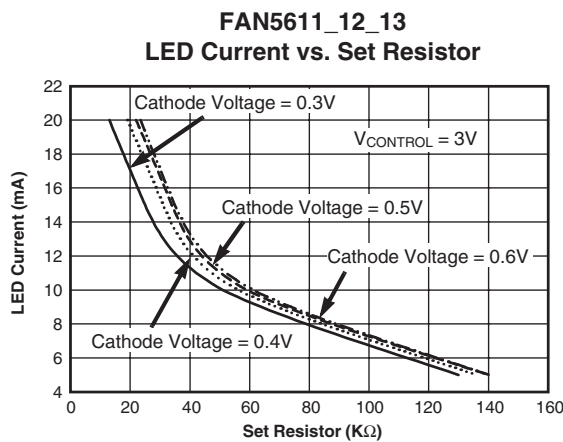
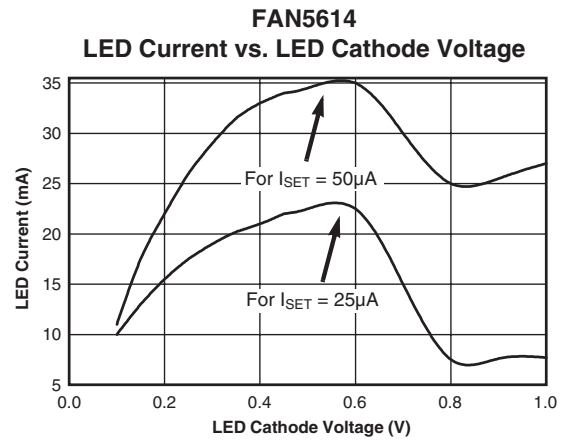
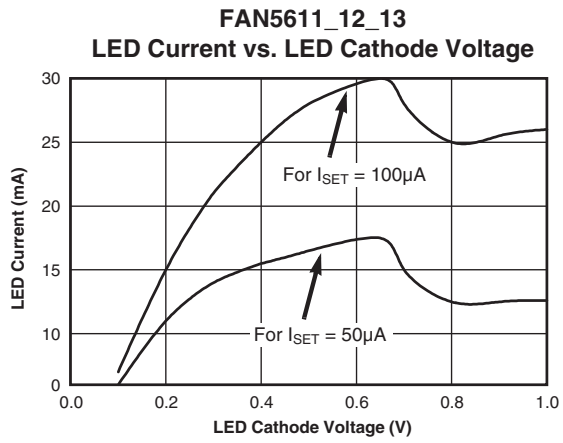
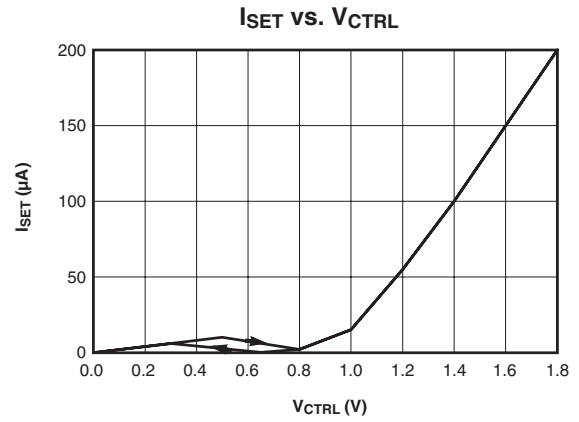
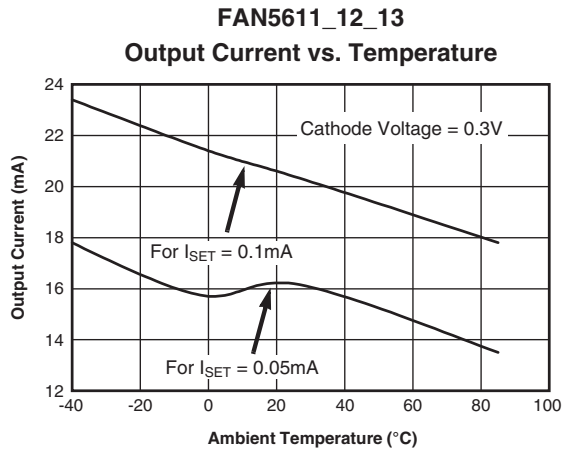

Typical Performance Characteristics (cont.)

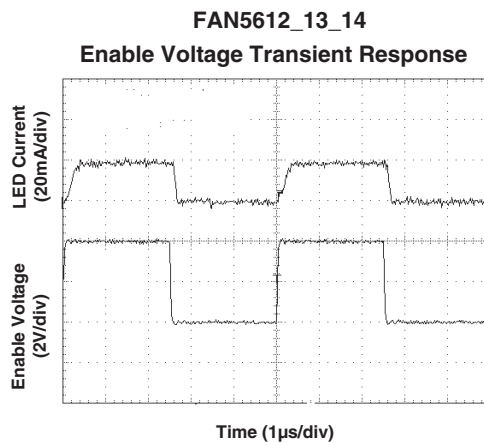
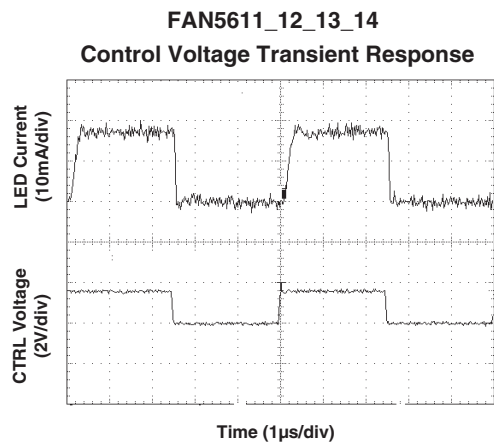

Application Information

Setting the LED Current

The current flowing into LEDs is approximately 200 times greater than the current I_{SET} . The LED current is controlled by $V_{CONTROL}$ and R_{SET} according to the formula:

$$I_{LED} = 200 \times (V_{CONTROL} - V_{CTRL}) / R_{SET}$$

For $V_{CONTROL} = 3V$ and a specified LED current, the R_{SET} value can be evaluated using the diagram shown in the Typical Performance Characteristics section. For any other option, I_{SET} value can be determined using the graph I_{SET} vs. V_{CTRL} . The LED's brightness can also be adjusted by driving ENABLE or the CTRL pin with a PWM signal. The driving signal frequency should be greater than 100Hz to avoid flickering, increasing to more than 1MHz, if necessary.

LEDs are very sensitive to temperature. In most cases the maximum allowed junction temperature is 100°C. This temperature is the result of adding to the ambient temperature the over temperature due to power dissipation, is described by as follows:

$$T_j = T_A + \Theta_{jA} \times I \times V_F$$

where T_j is the LED junction temperature, T_A is the ambient temperature, Θ_{jA} is the junction to ambient thermal resistance, I is the LED current and V_F is the LED forward voltage.

The FAN5611 to FAN5614 are designed to reduce the current through LEDs, when the temperature rises and the cathode voltage increases, as can be seen from typical the "LED Current vs. LED Cathode Voltage" graph under the Typical Performance Characteristics section.

Efficiency Considerations

The FAN561X driver's low dropout architecture can significantly improve the efficiency compared to using simple ballast resistors. The system efficiency, defined as the ratio between the LEDs power and the input supplied power can be calculated as follows:

$$\text{Efficiency} = (V_{IN} - V_{CATHODE}) / V_{IN}$$

The lower the $V_{CATHODE}$, the higher the system efficiency. Efficiency can be further improved using a higher V_{IN} with more LEDs as shown in example 3.

Application Notes

The ultra-low voltage drop across the FAN561X series of LED drivers, allow the devices to drive white, blue, and other color LEDs in a wide range of input voltages. The driver can be used in many applications. Although, only the FAN5613 is shown in all three examples, any of the FAN561X series of LED drivers can be used in the applications presented in this document, due to their similar operation.

Example 1: Drive low V_F white or blue LEDs directly from single cell Li-ion

When using white or blue low V_F LEDs, and utilizing the drivers low voltage drop, only 3.4V in V_{IN} is needed for the full 20mA LED current. At 3.1V, there is still 5mA typical current available for the LEDs. The single cell Li-ion is utilized in most applications like cell phones or digital still cameras. In most cases, the Li-ion battery voltage level only goes down to 3.0V voltage level, and not down to the full discharge level (2.7V) before requesting the charger.

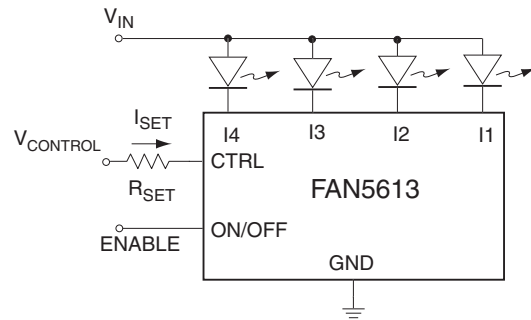

- $V_{DROP} < 0.3V$
- V_F (at 20mA) $< 3.1V$ (Low V_F)
- V_{IN} (at 20mA) $= V_{DROP} + V_F = 3.4V$
- V_{IN} (at 5mA Typical) $\sim 3.1V$

Where V_{IN} = Single cell Li-ion Voltage

Key advantages:

- No boost circuit needed for the LCD or keyboard backlight
- Drivers directly connected to a Li-ion battery
- No EMI, no switching noise, no boost efficiency lost, no capacitor, and no inductor.

Example 2: Drive high V_F white or blue LEDs from existing bus from 4.0V to 5.5V

High V_F white or blue LEDs have forward voltage drop in the range of 3.2V to 4.0V. To drive these LEDs with the maximum current of 20mA for maximum brightness, usually requires a boost circuit for a single cell Li-ion voltage range.

In some cases, there is already a voltage bus in the system, which can be utilized. Due to the ultra-low voltage drop of the FAN561X series of LED drivers to drive high V_F white or blue LEDs. The V_{IN} needs to be only 300mV higher than the highest V_F in the circuit.

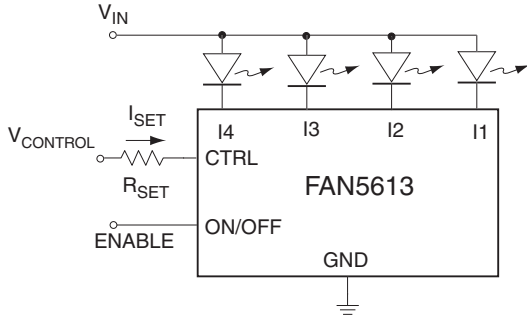

- $V_{DROP} < 0.3V$
- V_F (at 20mA) $< 3.3V$ to 4.0V (High V_F)
- V_{IN} (at 20mA) $= V_{DROP} + V_F = 3.6V$ to 4.3V
- V_{IN} (at 5mA Typical) $\sim 3.3V$

Where V_{IN} = Existing bus = 3.3V to 4.3V

Key advantages:

- No boost circuit needed for LCD or keyboard backlight
- Driver utilizes the existing bus
- Ultra-low voltage drop provides the full 20mA LED current at the lowest possible voltage level.

Example 3: Drive white, blue, red, amber LEDs string

Assuming boost circuit, or existing voltage bus, the FAN561X series of LED drivers can be used to drive a whole string of LEDs and flexible brightness control - analog and/or PWM.

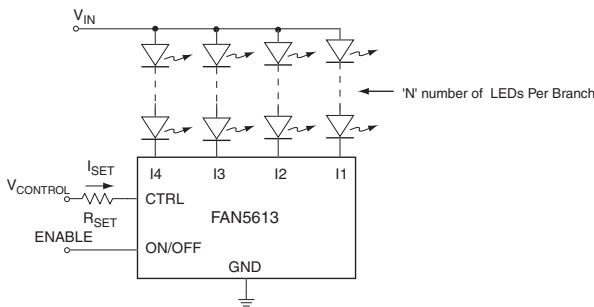

- $V_{DROP} < 0.3V$
- $V_{IN_MIN} = N \times V_F + V_{DROP}$
- $V_{IN_MAX} = N \times V_F + 5.5V$

Where V_{IN} = Existing bus, boost voltage

Key advantage:

- No need for current matching resistors and discrete transistor for brightness control

LED Brightness Control

All of the FAN561X LED Drivers feature analog and PWM controls to give designers flexible brightness control. These control methods can be applied to the circuit in two different ways, to provide more flexibility than any other solution. To determine the value of R_{SET} , use the “ I_{SET} vs. V_{CTRL} ” graph under the Typical Performance Characteristics section.

1. FAN5611

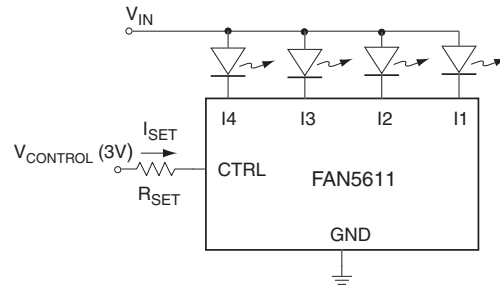

- Analog

Set $V_{CONTROL}$ and R_{SET} for LED current

$$I_{LED} = \frac{200 \times (V_{CONTROL} - V_{CTRL})}{R_{SET}}$$

- PWM

$V_{CONTROL} = PWM$

- Amplitude sets maximum LED current
- Pulse width controls between 0 and maximum

2. FAN5612

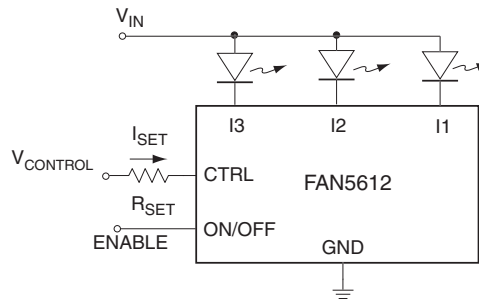

- Analog

Set $V_{CONTROL}$ and R_{SET} for LED current

- PWM - 1

$$I_{LED} = \frac{200 \times (V_{CONTROL} - V_{CTRL})}{R_{SET}}$$

$V_{CONTROL} = PWM$

- Amplitude sets maximum LED current
- Pulse width controls between 0 and maximum

- PWM - 2

Set $V_{CONTROL}$ and R_{SET} for maximum LED current

$$I_{LED} \sim 200 \times I_{SET}$$

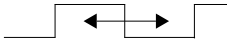
ON/OFF = PWM 

- Amplitude has no effect on current
- Pulse width controls between 0 and maximum

3. FAN5613

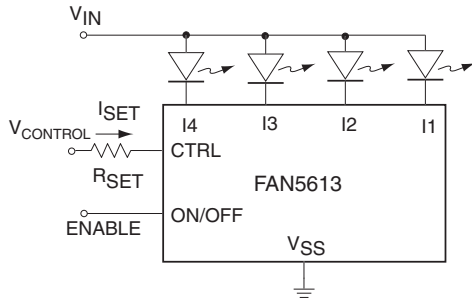

- Analog

Set $V_{CONTROL}$ and R_{SET} for LED current

$$I_{LED} = \frac{200 \times (V_{CONTROL} - V_{CTRL})}{R_{SET}}$$

- PWM - 1

$V_{CONTROL} = PWM$ 

- Amplitude sets maximum LED current
- Pulse width controls between 0 and maximum

- PWM - 2

Set $V_{CONTROL}$ and R_{SET} for maximum LED current

$$I_{LED} \sim 200 \times I_{SET}$$

ON/OFF = PWM 

- Amplitude has no effect on current
- Pulse width controls between 0 and maximum

4. FAN5614

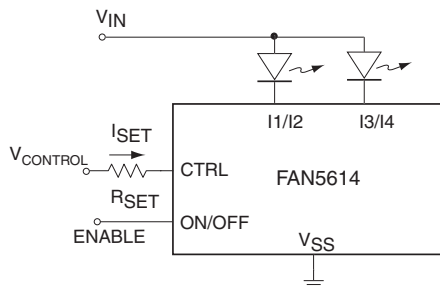

- Analog

Set $V_{CONTROL}$ and R_{SET} for LED current

$$I_{LED} = \frac{200 \times (V_{CONTROL} - V_{CTRL})}{R_{SET}}$$

- PWM - 1

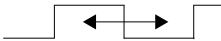
$V_{CONTROL} = PWM$ 

- Amplitude sets maximum LED current
- Pulse width controls between 0 and maximum

- PWM - 2

Set $V_{CONTROL}$ and R_{SET} for maximum LED current

$$I_{LED} \sim 200 \times I_{SET}$$

$$I_{LED} = \frac{200 \times (V_{CONTROL} - V_{CTRL})}{R_{SET}}$$

ON/OFF = PWM 

- Amplitude has no effect on current
- Pulse width controls between 0 and maximum

Mechanical Dimensions

2mmx 2mm 8-Lead MLP

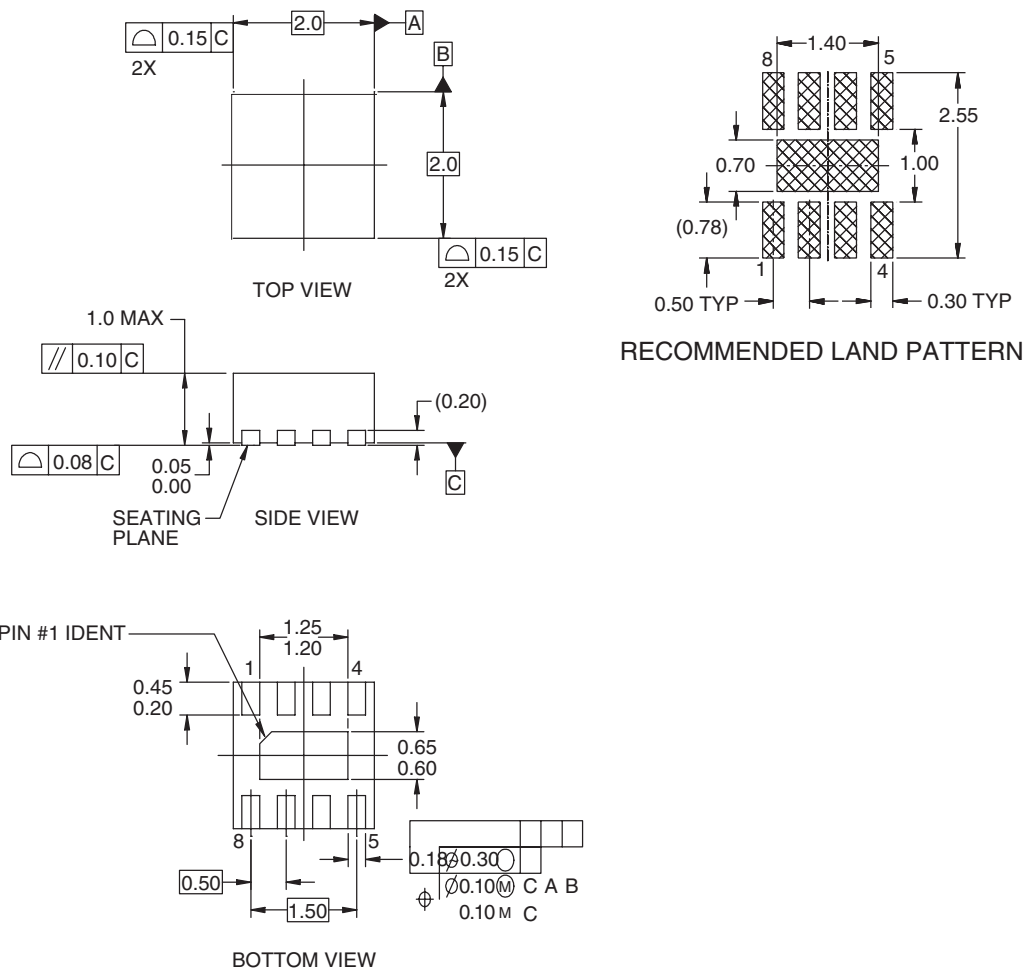

NOTES:

- A. CONFORMS TO JEDEC REGISTRATION MO-229, VARIATION VCCD-3, DATED 11/2001
- B. DIMENSIONS ARE IN MILLIMETERS.
- C. DIMENSIONS AND TOLERANCES PER ASME Y14.5M, 1994

Mechanical Dimensions

6-Lead SC-70 Package

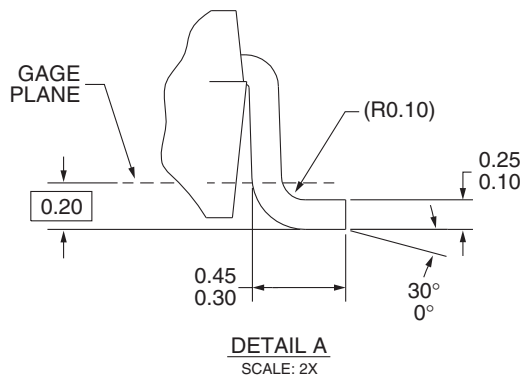
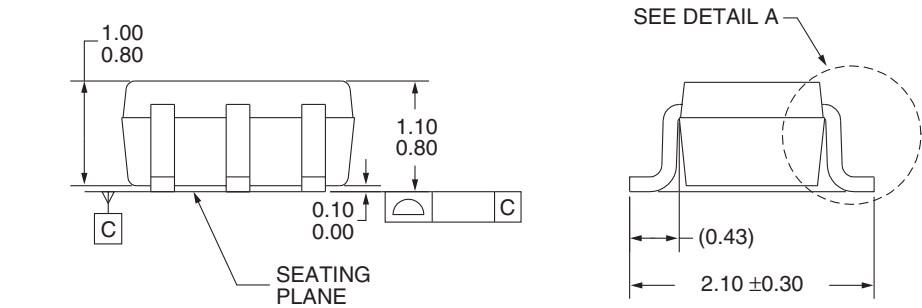
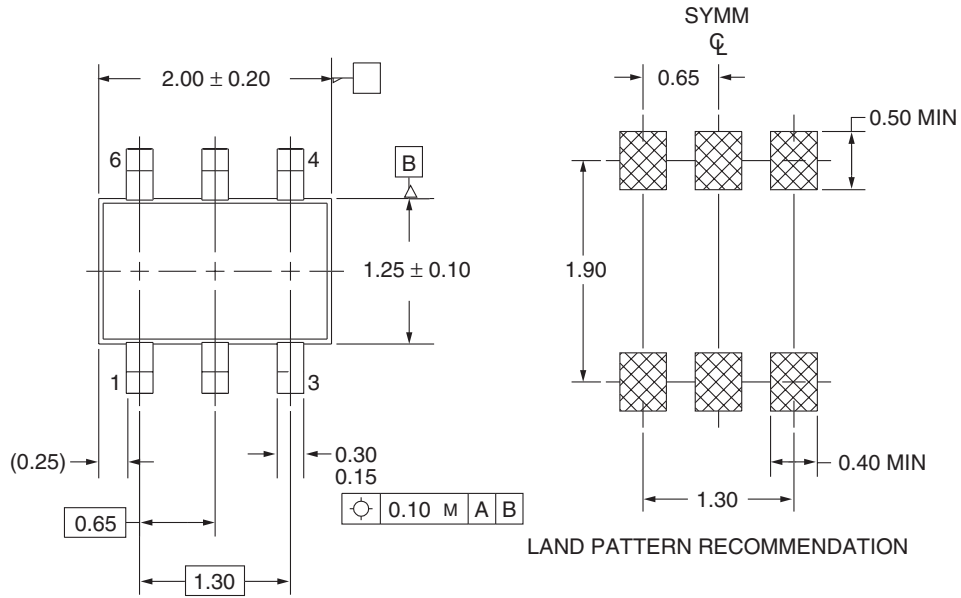

- NOTES: UNLESS OTHERWISE SPECIFIED
- A) THIS PACKAGE CONFORMS TO EIAJ SC-88A, 1996.
 - B) ALL DIMENSIONS ARE IN MILLIMETERS.
 - C) DIMENSIONS DO NOT INCLUDE BURRS OR MOLD FLASH.

Ordering Information

Product Number	Package Type	Order Code
FAN5611	6-Lead SC-70	FAN5611S7X
FAN5612	6-Lead SC-70	FAN5612S7X
FAN5613	2mm x 2mm 8-Lead MLP	FAN5613MPX
FAN5614	6-Lead SC-70	FAN5614S7X

DISCLAIMER

FAIRCHILD SEMICONDUCTOR RESERVES THE RIGHT TO MAKE CHANGES WITHOUT FURTHER NOTICE TO ANY PRODUCTS HEREIN TO IMPROVE RELIABILITY, FUNCTION OR DESIGN. FAIRCHILD DOES NOT ASSUME ANY LIABILITY ARISING OUT OF THE APPLICATION OR USE OF ANY PRODUCT OR CIRCUIT DESCRIBED HEREIN; NEITHER DOES IT CONVEY ANY LICENSE UNDER ITS PATENT RIGHTS, NOR THE RIGHTS OF OTHERS.

LIFE SUPPORT POLICY

FAIRCHILD'S PRODUCTS ARE NOT AUTHORIZED FOR USE AS CRITICAL COMPONENTS IN LIFE SUPPORT DEVICES OR SYSTEMS WITHOUT THE EXPRESS WRITTEN APPROVAL OF THE PRESIDENT OF FAIRCHILD SEMICONDUCTOR CORPORATION. As used herein:

1. Life support devices or systems are devices or systems which, (a) are intended for surgical implant into the body, or (b) support or sustain life, and (c) whose failure to perform when properly used in accordance with instructions for use provided in the labeling, can be reasonably expected to result in a significant injury of the user.
2. A critical component in any component of a life support device or system whose failure to perform can be reasonably expected to cause the failure of the life support device or system, or to affect its safety or effectiveness.