

FAN1537

Dual 1A Adjustable/Fixed Low Dropout Linear Regulators

Features

- Low dropout voltage
- Load regulation: 0.05% typical
- On-chip thermal limiting
- SO-8 and 5-lead SPAK and TO-252 DPAK packages
- Fixed 3.3V, and adjustable or 2.5V or 1.8V fixed
- Stable with low ESR output capacitors

Applications

- Hard Disk Drives, CD-ROMs, DVDs
- High efficiency linear regulators
- Post regulators for switching supplies
- ADSL and Cable Modems
- 5V to 3.3V and 2.5V linear regulators
- Motherboard with multiple supplies

Description

The FAN1537 provides 2 output voltages: 3.3V, and either adjustable or 2.5V or 1.8V fixed with 1.0A each output current capability. These devices have been optimized for low voltage where transient response and minimum input voltage are critical.

Current limit features protect the outputs against short circuit currents. On-chip thermal limiting provides protection against any combination of overload and ambient temperature that would create excessive junction temperatures.

The FAN1537 series regulators are available in SO-8 and 5-lead SPAK and TO-252 DPAK power packages.

Typical Applications

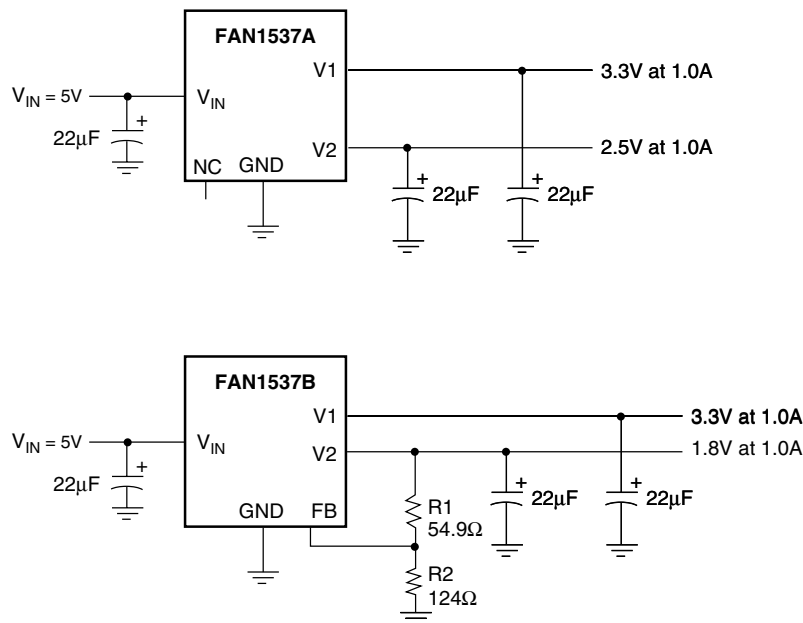

$$V2 = V_{REF} (1 + R1/R2)$$

Pin Assignments

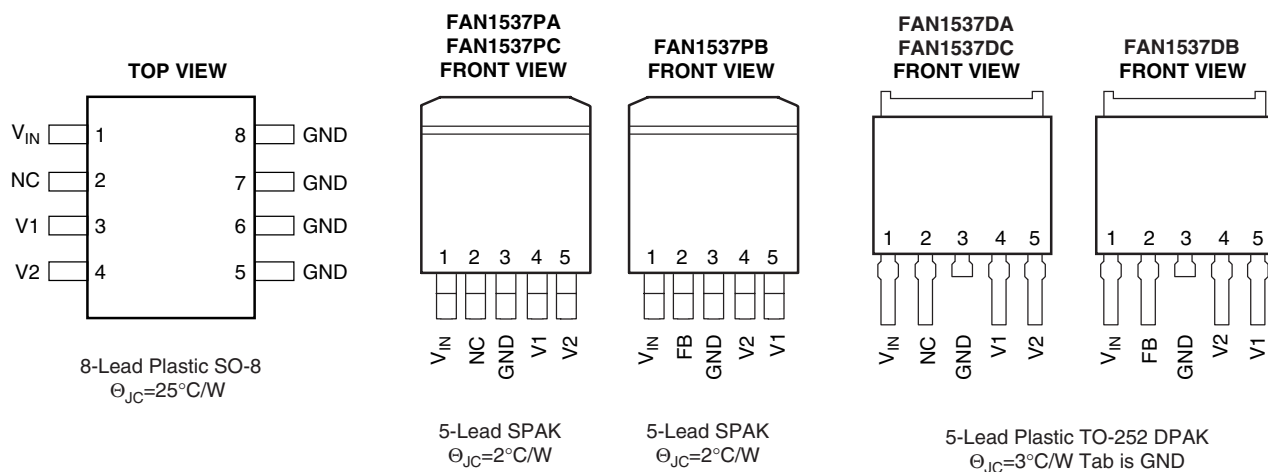

Pin Descriptions

| Pin Name | SO-8 | SPAK DPAK | Pin Function |
|-----------------|------------|-----------|--|
| V _{IN} | 1 | 1 | Input supply voltage |
| NC/FB | 2 | 2 | For V ₂ fixed, no connect. For V ₂ adjustable, feedback voltage. |
| V ₁ | 3 | 4/5 | Output #1 |
| V ₂ | 4 | 5/4 | Output #2 |
| GND | 5, 6, 7, 8 | 3 | Ground |

Absolute Maximum Ratings

| Parameter | Min. | Max. | Unit |
|---------------------------------------|------|------|------|
| V _{IN} | | 10 | V |
| Operating Junction Temperature Range | 0 | 150 | °C |
| Storage Temperature Range | -65 | 150 | °C |
| Lead Temperature (Soldering, 10 sec.) | | 300 | °C |

Electrical Characteristics (Operating Conditions: $V_{IN} \leq 7V$, $T_J=25^\circ C$ unless otherwise specified.)

The • denotes specifications which apply over the specified operating temperature range of $0^\circ C$ to $125^\circ C$ junction temperature.

| Parameter | Conditions | Min. | Typ. | Max. | Units |
|--|---|--|--|--|--------------|
| Output Voltages | $10mA \leq I_{OUT} \leq 1A$ $4.75V \leq V_{IN} \leq 7V$ | • 1.764 • 1.742 • 2.450 • 2.420 • 3.234 • 3.200 | 1.8 1.8 2.500 2.500 3.300 3.300 | 1.836 1.858 2.550 2.580 3.366 3.400 | V |
| Output Voltage | 3.3V Output, $V_{IN} = 4.5V$, $I_{OUT} = 1A$ | • 3.2 | | | V |
| Time to Output Voltages Valid | From $V_{IN} \geq 4.75V$ | | | 5 | msec |
| Reference Voltage, V_{REF} | $10mA \leq I_{OUT} \leq 1A$ $4.75V \leq V_{IN} \leq 7V$ | • 1.225 • 1.210 | 1.250 1.250 | 1.275 1.290 | V |
| Line Regulation ^{1,2} (both outputs) | $4.75V \leq V_{IN} \leq 7V$, $I_{OUT} = 10mA$ | • | 0.005 | 0.5 | % |
| Load Regulation ^{1,2} (both outputs) | $V_{IN} = 4.75V$, $10mA \leq I_{OUT} \leq 1A$ | • | 0.05 | 0.5 | % |
| Dropout Voltage (3.3V output) | $\Delta V_{OUT} = 1\%$, $I_{OUT} = 1A$ | • | 1.100 | 1.300 | V |
| Current Limit (both outputs) | $V_{IN} = 5V$ | • 1.3 | 1.5 | | A |
| Minimum Load Current (both outputs) | $4.75V \leq V_{IN} \leq 7V$ | • 10 | | | mA |
| Quiescent Current | $V_{IN} = 7V$ | • | 6 | 15 | mA |
| Ripple Rejection ³ (both outputs) | $f = 120Hz$, $C_{OUT} = 22\mu F$ Tantalum, $V_{IN} = 5V$, $I_{OUT} = 1A$ | • 60 | | | dB |
| Long-Term Stability | $T_A = 125^\circ C$, 1000 hrs. | | 0.03 | 1.0 | % |
| RMS Output Noise (% of V_{OUT}) | $T_A = 25^\circ C$, $10Hz \leq f \leq 10kHz$ | | 0.003 | | % |
| Thermal Resistance, Junction to Case | SO-8 | | 50 | | $^\circ C/W$ |
| | TO-252 DPAK | | 3 | | $^\circ C/W$ |
| | SPAK | | 2 | | $^\circ C/W$ |
| Thermal Shutdown | | | 155 | | $^\circ C$ |
| Thermal Shutdown Hysteresis | Junction Temperature | | 10 | | $^\circ C$ |

Notes:

- See thermal regulation specifications for changes in output voltage due to heating effects. Load and line regulation are measured at a constant junction temperature by low duty cycle pulse testing.
- Power dissipation is determined by input/output differential and the output current. Guaranteed maximum output power will not be available over the full input/output voltage range.
- ESR = 0.2Ω .
- For adjust only, $V_{OUT} = V_{REF} (1 + R1/R2)$

Application Hints

External Capacitors

Like any low-dropout regulator, the FAN1537 requires external capacitors for stability.

Input Capacitor

A Tantalum input capacitor of 22 μ F is recommended. This capacitor must be located at a distance of no more than 0.5" from the input pin of the device and returned to a clean analog ground.

Output Capacitor

The FAN1537 is designed to work with Ceramic or Tantalum load capacitors.

A value of 22 μ F is recommended on each output, but the value can be reduced to 10 μ F to save space.

Additional capacitance can be added without limit for better performance, e.g. improved transient response and lower noise.

When a Ceramic multilayer capacitor is used, the X7R dielectric is recommended which holds the capacitance within $\pm 15\%$. The output capacitor should be located not more than 0.5" from the output pins of the device and returned to a clean analog ground.

Mechanical Dimensions

8-Lead SOIC Package

| Symbol | Inches | | Millimeters | | Notes |
|----------|----------|------|-------------|------|-------|
| | Min. | Max. | Min. | Max. | |
| A | .053 | .069 | 1.35 | 1.75 | |
| A1 | .004 | .010 | 0.10 | 0.25 | |
| B | .013 | .020 | 0.33 | 0.51 | |
| C | .0075 | .010 | 0.20 | 0.25 | 5 |
| D | .189 | .197 | 4.80 | 5.00 | 2 |
| E | .150 | .158 | 3.81 | 4.01 | 2 |
| e | .050 BSC | | 1.27 BSC | | |
| H | .228 | .244 | 5.79 | 6.20 | |
| h | .010 | .020 | 0.25 | 0.50 | |
| L | .016 | .050 | 0.40 | 1.27 | 3 |
| N | 8 | | 8 | | 6 |
| α | 0° | 8° | 0° | 8° | |
| ccc | — | .004 | — | 0.10 | |

Notes:

1. Dimensioning and tolerancing per ANSI Y14.5M-1982.
2. "D" and "E" do not include mold flash. Mold flash or protrusions shall not exceed .010 inch (0.25mm).
3. "L" is the length of terminal for soldering to a substrate.
4. Terminal numbers are shown for reference only.
5. "C" dimension does not include solder finish thickness.
6. Symbol "N" is the maximum number of terminals.

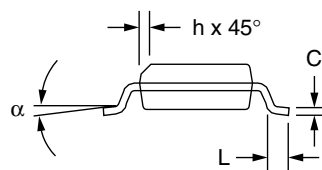
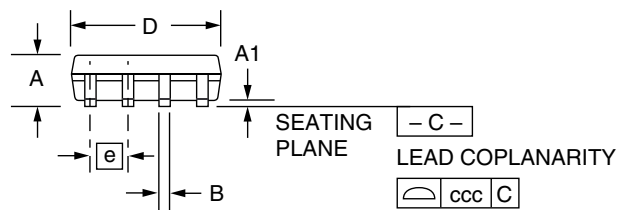
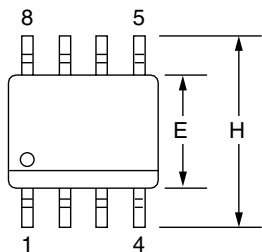

Mechanical Dimensions

5-Lead SPAK

| Symbol | Inches | | Millimeters | | Notes |
|----------|-----------|-------|-------------|-------|-------|
| | Min. | Max. | Min. | Max. | |
| A | 0.350 | 0.360 | 8.89 | 9.14 | |
| B | 0.220 NOM | | 5.59 NOM | | |
| b1 | 0.268 | | 6.81 | | |
| b2 | 0.025 | 0.031 | 0.63 | 0.79 | |
| C | 0.070 | 0.080 | 1.78 | 2.03 | |
| c1 | 0.040 | 0.050 | 1.02 | 1.27 | |
| c2 | 0.010 NOM | | 0.25 NOM | | |
| D | 0.295 NOM | | 7.49 NOM | | |
| E | 0.365 | 0.375 | 9.27 | 9.52 | |
| e | 0.067 | | 1.72 | | |
| L | 0.410 | 0.420 | 10.41 | 10.67 | |
| L1 | 0.031 | 0.041 | 0.79 | 1.04 | |
| L2 | 0.350 | 0.360 | 8.89 | 9.14 | |
| L3 | 0.310 | 0.320 | 7.87 | 8.13 | |
| R | 0.010 NOM | | 0.25 NOM | | |
| α | 0° | 8° | 0° | 8° | |

Notes:

1. All linear dimensions are in inches (millimeters).
2. This drawing is subject to change without notice.
3. The center lead is in electrical contact with the thermal tab.
4. Dimensions do not include mold protrusions, not to exceed 0.006 (0,15).

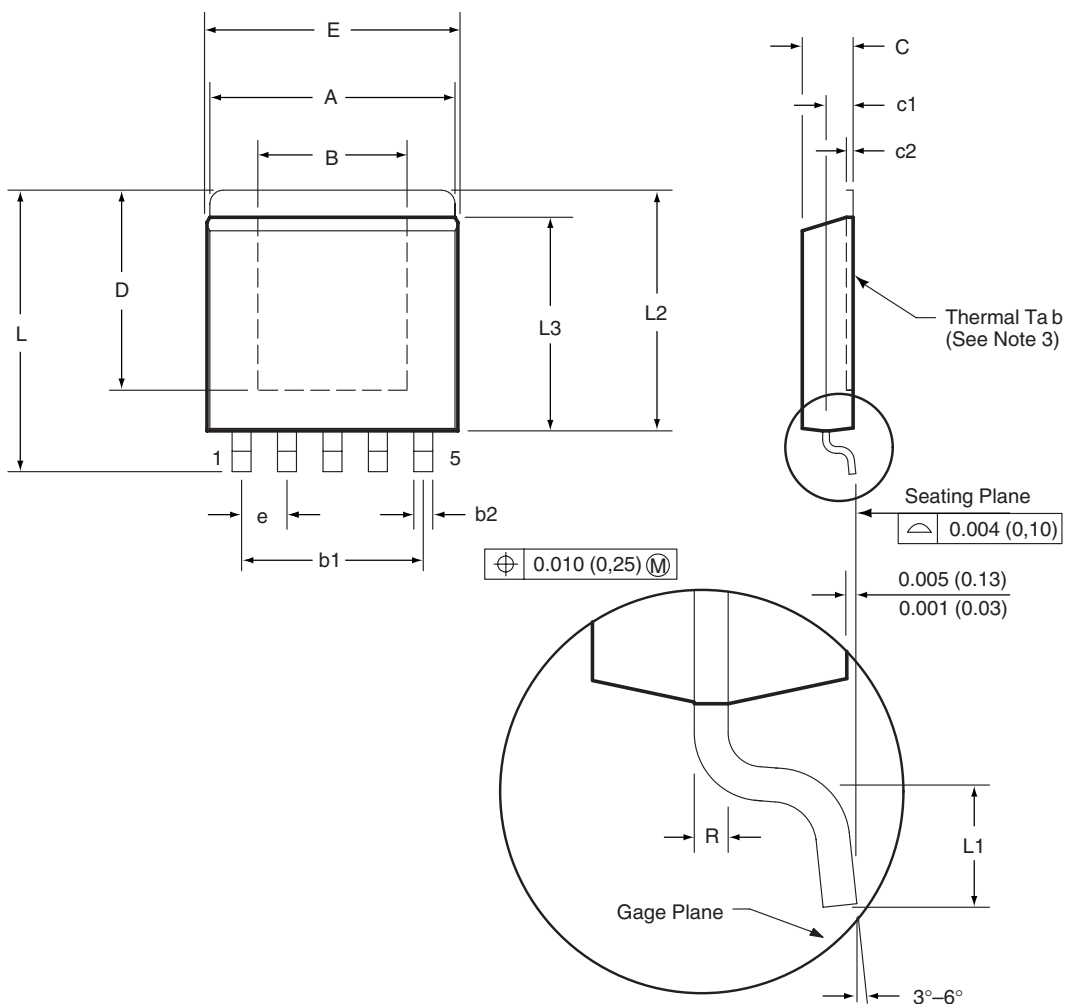

Mechanical Dimensions

5-Lead TO-252 Package

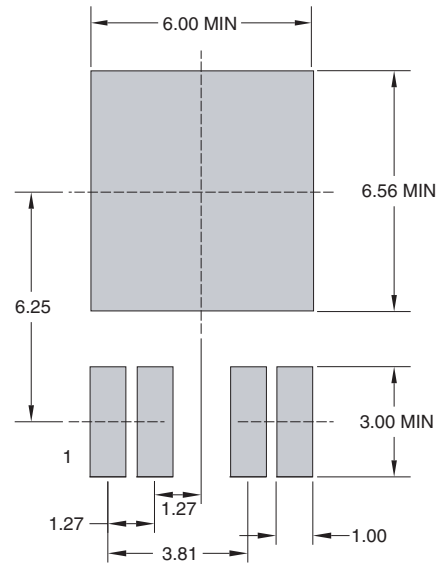
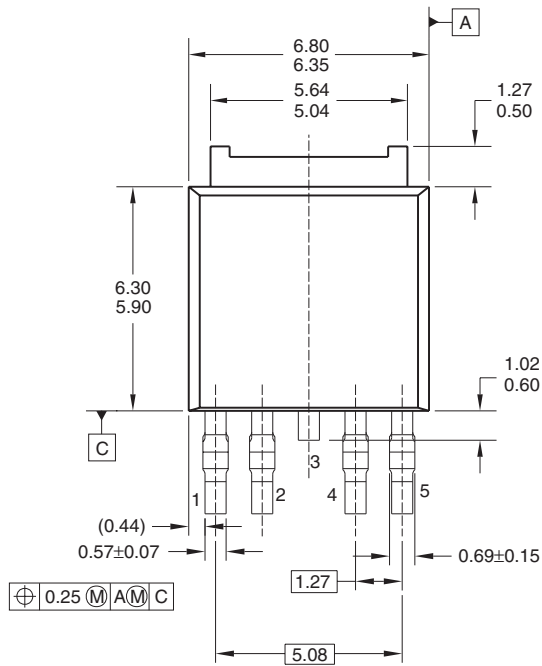

LAND PATTERN RECOMMENDATION

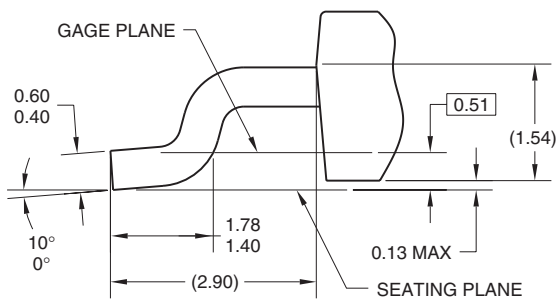
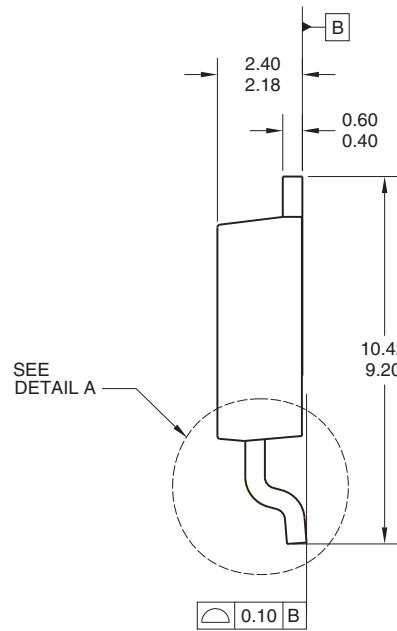
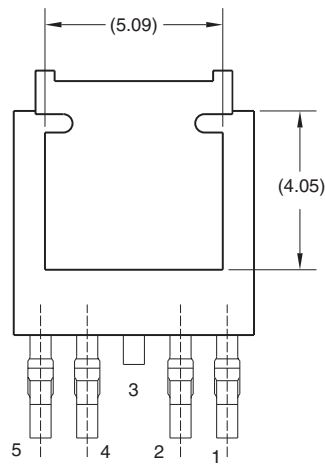

DETAIL A
(ROTATED 90°)
SCALE: 2X

NOTES: UNLESS OTHERWISE SPECIFIED

- A) ALL DIMENSIONS ARE IN MILLIMETERS.
- B) THIS PACKAGE CONFORMS TO JEDEC, TO-252, ISSUE C, VARIATION AA, DATED NOV. 1999.

Ordering Information

Example: FAN1537PA

FAN1537

P

A

M = SO-8
P = SPAK
D = TO-252 DPAK

Table 1

Table 1.

| Suffix | V1 | V2 |
|--------|------|------|
| A | 3.3V | 2.5V |
| B | 3.3V | ADJ |
| C | 3.3V | 1.8V |

DISCLAIMER

FAIRCHILD SEMICONDUCTOR RESERVES THE RIGHT TO MAKE CHANGES WITHOUT FURTHER NOTICE TO ANY PRODUCTS HEREIN TO IMPROVE RELIABILITY, FUNCTION OR DESIGN. FAIRCHILD DOES NOT ASSUME ANY LIABILITY ARISING OUT OF THE APPLICATION OR USE OF ANY PRODUCT OR CIRCUIT DESCRIBED HEREIN; NEITHER DOES IT CONVEY ANY LICENSE UNDER ITS PATENT RIGHTS, NOR THE RIGHTS OF OTHERS.

LIFE SUPPORT POLICY

FAIRCHILD'S PRODUCTS ARE NOT AUTHORIZED FOR USE AS CRITICAL COMPONENTS IN LIFE SUPPORT DEVICES OR SYSTEMS WITHOUT THE EXPRESS WRITTEN APPROVAL OF THE PRESIDENT OF FAIRCHILD SEMICONDUCTOR CORPORATION. As used herein:

1. Life support devices or systems are devices or systems which, (a) are intended for surgical implant into the body, or (b) support or sustain life, and (c) whose failure to perform when properly used in accordance with instructions for use provided in the labeling, can be reasonably expected to result in a significant injury of the user.
2. A critical component in any component of a life support device or system whose failure to perform can be reasonably expected to cause the failure of the life support device or system, or to affect its safety or effectiveness.