



## 250-mA MULTI-INPUT LOW-DROPOUT REGULATOR WITH DUAL -OUTPUT POWER MANAGEMENT

### Features

- Complete Power Management
- Automatic Input Voltage Selection
- Input Voltage Source Detector With Hysteresis
- 250-mA Load Current Capability With VCC50 or VSB50 or AUX33 Input Source
- Integrated Low  $r_{DS(on)}$  Switch
- Dual Regulated Output 3.3V (fixed) & 1.8V (fixed)
- Output Short Circuit Protection

### Pin Configuration

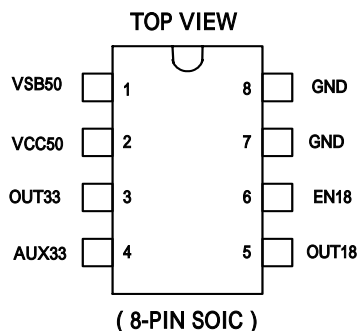

### Description

The AAT1202 is a multi-input low-dropout regulator that provides dual constant output supply 3.3V & 1.8V at the output capable of driving a 250-mA load.

The output (OUT18) can be disable by connect EN18 pin to GND.

The AAT1202 provides dual regulated power output for systems that have multiple input sources and require dual constant voltage source with a low-dropout voltage. This is a intelligent power source selection device with a low-dropout regulator for either VCC50 or VSB50 inputs, and a low-resistance bypass switch for the AUX33 input.

Transitions may occur from one input supply to another without generating a glitch outside of the specification range on the 3.3-V & 1.8-V output. The device has an incorporated reverse-blocking scheme to prevent excess leakage from the input terminals in the event that the output voltage is greater than the input voltage.

The input voltage is prioritized in the following order: VCC50, VSB50, AUX33.



**Functions Table**

INPUT VOLTAGE STATUS (V)				INPUT SELECTED	OUTPUT (V)		OUTPUT (I)(mA)
EN18	VCC50	VSB50	AUX33	VCC50/VSB50/AUX33	OUT33	OUT18	Iout33+Iout18
Hi	0	0	0	None	0	0	0
Low	0	0	0	None	0	0	0
Hi	0	0	3.3	AUX33	3.3	1.8	250
Low	0	0	3.3	AUX33	3.3	0	250
Hi	0	5	0	VSB50	3.3	1.8	250
Low	0	5	0	VSB50	3.3	0	250
Hi	0	5	3.3	VSB50	3.3	1.8	250
Low	0	5	3.3	VSB50	3.3	0	250
Hi	5	0	0	VCC50	3.3	1.8	250
Low	5	0	0	VCC50	3.3	0	250
Hi	5	0	3.3	VCC50	3.3	1.8	250
Low	5	0	3.3	VCC50	3.3	0	250
Hi	5	5	0	VCC50	3.3	1.8	250
Low	5	5	0	VCC50	3.3	0	250
Hi	5	5	3.3	VCC50	3.3	1.8	250
Low	5	5	3.3	VCC50	3.3	0	250

**Pin Description**

TERMINAL NAME	NO.	I/O	Description
VSB50	1	I	5-V standby supply input
VCC50	2	I	5-V main supply input
OUT33	3	O	3.3-V regulated output
AUX33	4	I	3.3-V auxiliary supply input
OUT18	5	O	1.8-V regulated output
EN18	6	I	Enable input of OUT18
GND	7	I	Ground
GND	8	I	Ground

**absolute maximum ratings<sup>†</sup>**

- Main Supply voltage,  $V_{(VCC50)}$  ..... -0.5V~7V
- Standby Supply voltage,  $V_{(VSB50)}$  ..... -0.5V~7V
- Auxiliary Supply voltage,  $V_{(AUX33)}$  ..... -0.5V~7V
- Output current limit,  $I_{(LIMIT)}$  ..... 1.5A
- Continuous power dissipation,  $P_D$  ( see Note 1 ) ..... 1.1W
- Electrostatic discharge susceptibility, human body model.....2kV
- Operating ambient temperature range,  $T_A$ .....0 to 70
- Storage temperature range,  $T_{stg}$ .....-55 to 150



- Operating junction temperature range,  $T_J$ .....-5 to 130
- Lead temperature (soldering, 10 second),  $T_{(LEAD)}$ .....260

NOTE 1 : The device deteriorate with increase in ambient temperature,  $T_A$ . See Thermal Information section.

**Recommended operating conditions**

	Min	Typ	Max	Unit
5-V main supply input, VCC50	4.5		5.5	V
5-V standby supply input, VSB50	4.5		5.5	V
3.3V auxiliary supply input, AUX33	3		3.6	V
Load capacitance, $C_L$	4.23	4.7	5.17	$\mu F$
Load current, $I_L$	0		250	mA
Ambient temperature, $T_A$	0		70	



Electrical Characteristics over recommended operating free-air temperature,  $T_A = 0$  to  $70$ ,  $C_L = 4.7\mu\text{F}$  (unless otherwise noted)

Parameter	Test Condition	Min	Typ	Max	Unit
VCC50 VSB50	5-V inputs	4.5	5	5.5	V
OUT33	3.3-V output	Iout33+Iout18 = 250mA		3.465	V
OUT18	1.8-V output	Iout33=0, Iout18 = 200mA		1.89	V
$V_{O(VO)}$	Line regulation voltage	VSB50 or VCC50 = 4.5V to 5.5V		2	mV
$V_{O(LO)}$	Load regulation voltage	20 mA < $I_L$ < 250 mA		40	mV
$I_{50}$	Quiescent supply current	From VCC50 VSB50 terminals, $I_L = 0$ to 250mA		3.0	mA
$I_{AUX}$		From AUX33 terminal, $I_L = 0A$		3.0	mA
$I_{L33}$	Out33 load current	0.25		1.5	A
$I_{L18}$	Out18 load current	0.2			
$I_{LIMIT}$	Output current limit	Out33 or Out18 output shorted to 0V			
$T_{TSD}$	Thermal shutdown ( NOTE 2 )	150		180	
$T_{hys}$	Thermal hysteresis ( NOTE 2 )	15			
$C_L$	Load capacitance	Minimal ESR to insure stability of regulated output		4.7	$\mu\text{F}$
$I_{IKG(REV)}$	Reverse leakage output current	Tested for input that is grounded. AUX33, VSB50 or VCC50 = GND, Out33 = 3.3v		50	$\mu\text{A}$
$V_{LO}$	Threshold voltage, low	VSB50 or VCC50↓		4.25	V
$V_{HI}$	Threshold voltage, high	VSB50 or VCC50↑		4.5	V
$R_{(SWITCH)}$	Auxiliary switch resistance	VSB50 = VCC50 = 0V, AUX33 = 3.3V, $I_L = 150\text{mA}$		0.4	$\Omega$
$R_{\theta JA}$	Thermal impedance, Junction-to-ambient ( NOTE3 )	Without copper for heat spreading		100	/W
		With copper for heat spreading		70	

NOTE 2 : Design targets only. Not tested in production.

NOTE 3 : Please refer to "Thermal Information"

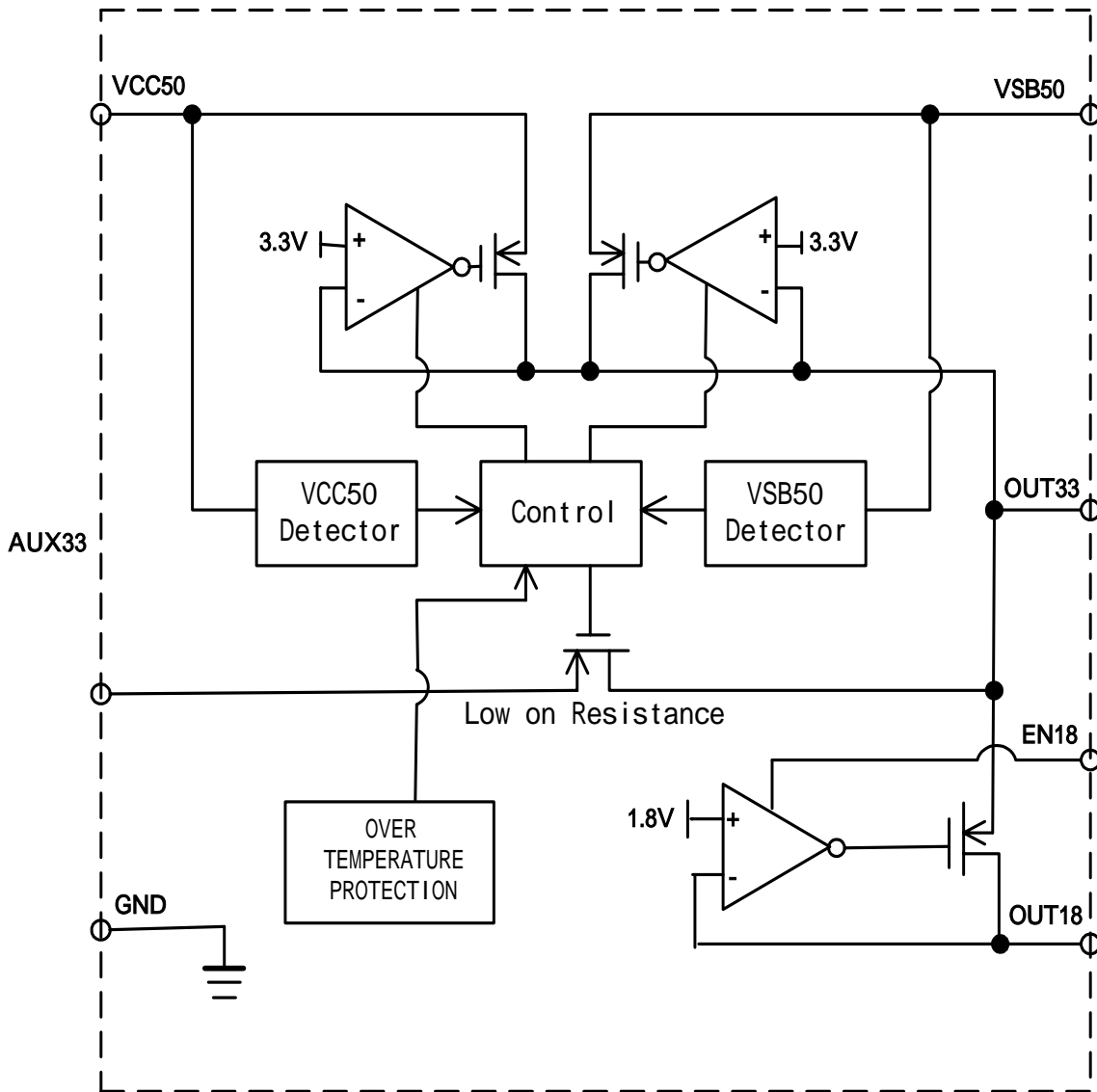



TYPICAL CHARACTERISTICS

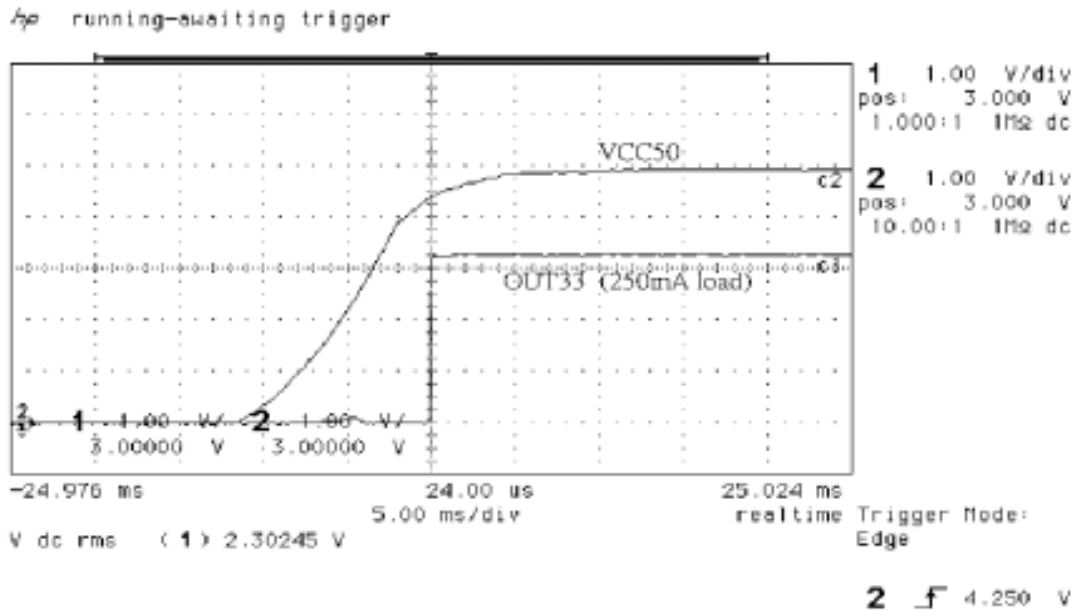

Figure 1. 3.3V VCC50 Cold Start

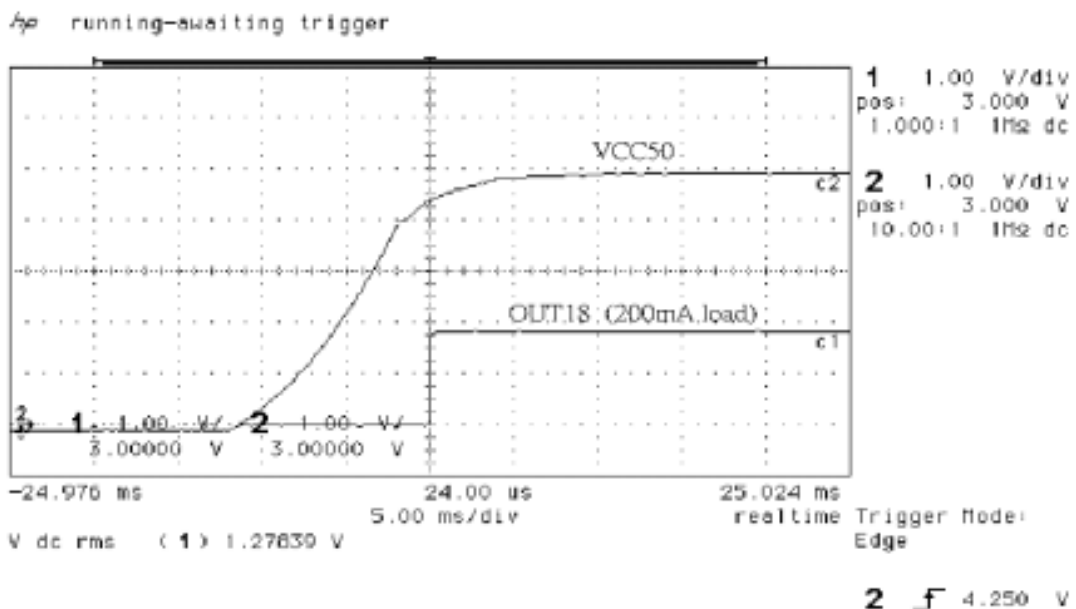

Figure 2. 1.8V VCC50 Cold Start



TYPICAL CHARACTERISTICS

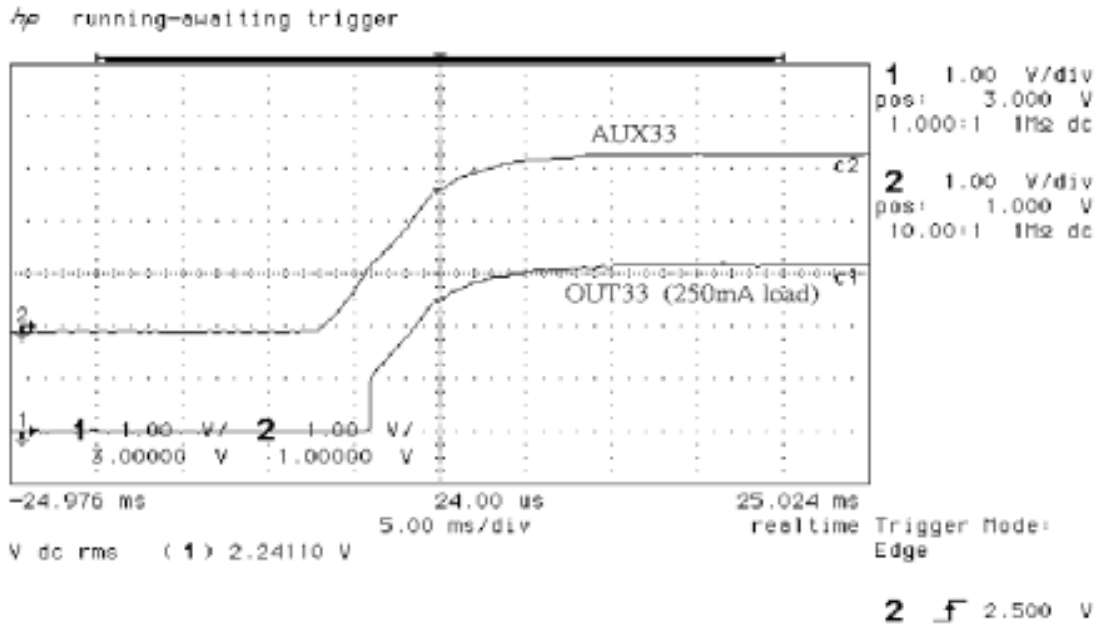

Figure 3. 3.3V AXX33 Cold Start

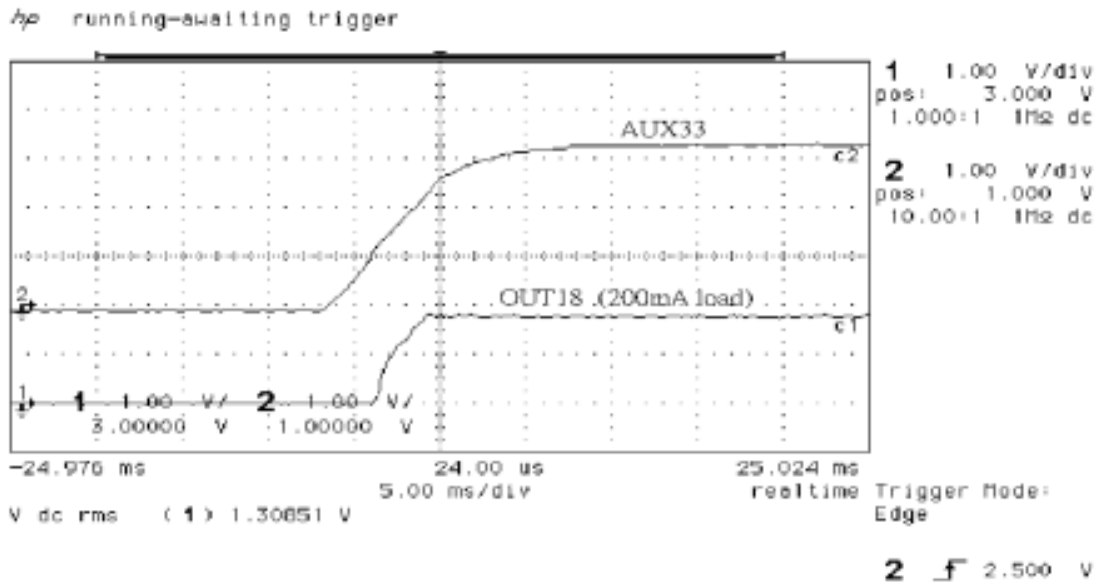

Figure 4. 1.8V AXX33 Cold Start



TYPICAL CHARACTERISTICS

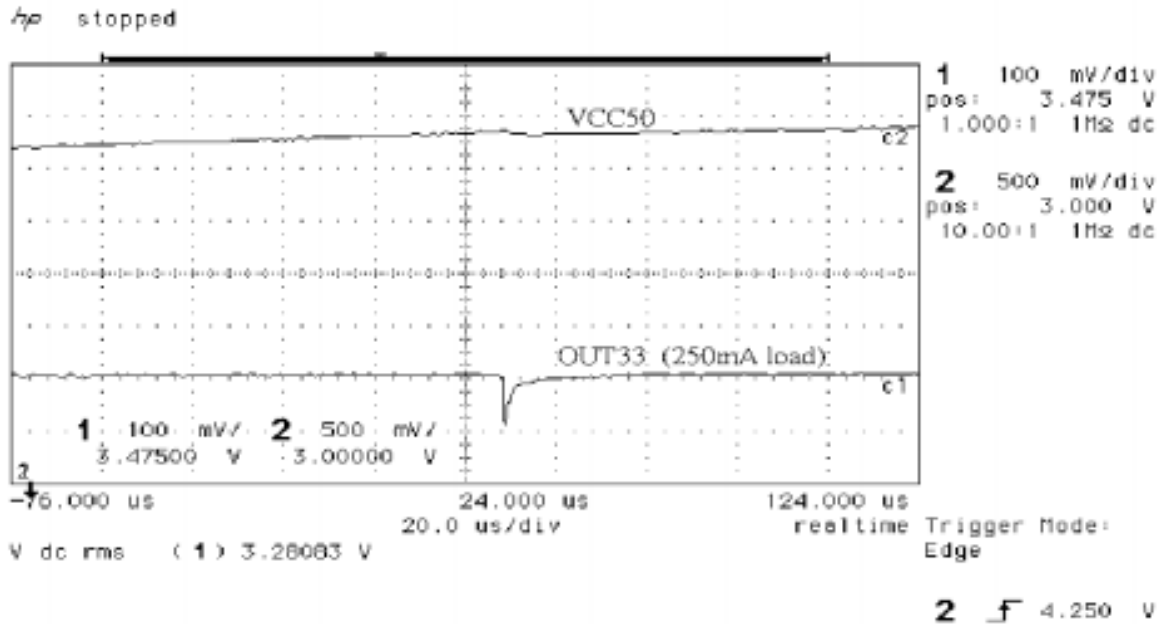

Figure 5. 3.3V VCC50 Power Up(VSB50=5V)

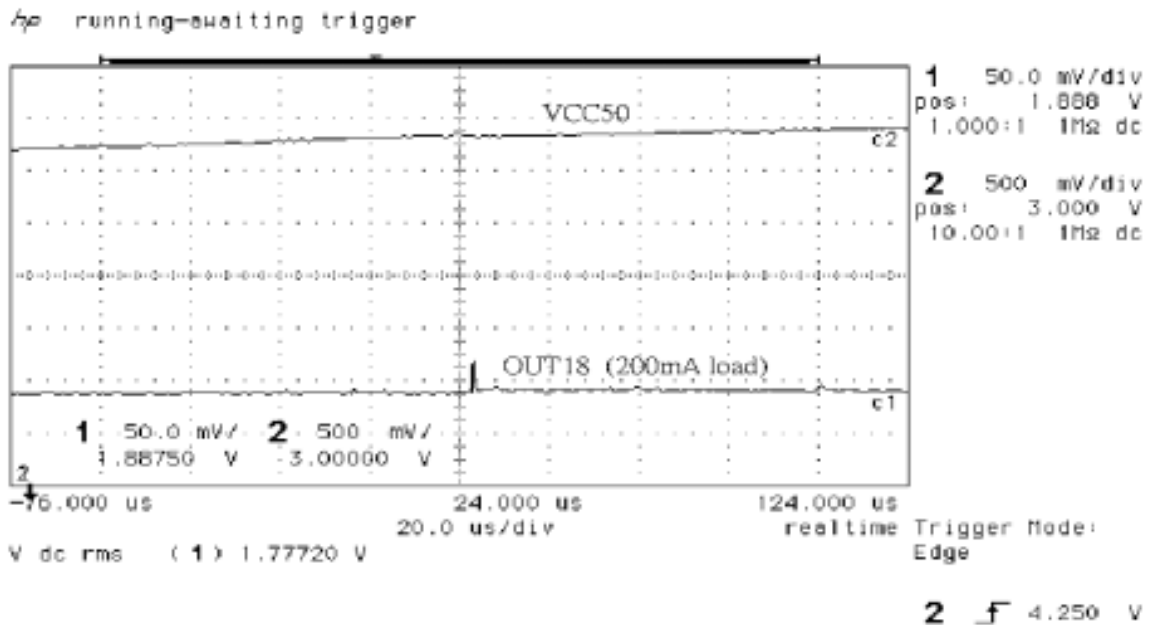

Figure 6. 1.8V VCC50 Power Up(VSB50=5V)





TYPICAL CHARACTERISTICS

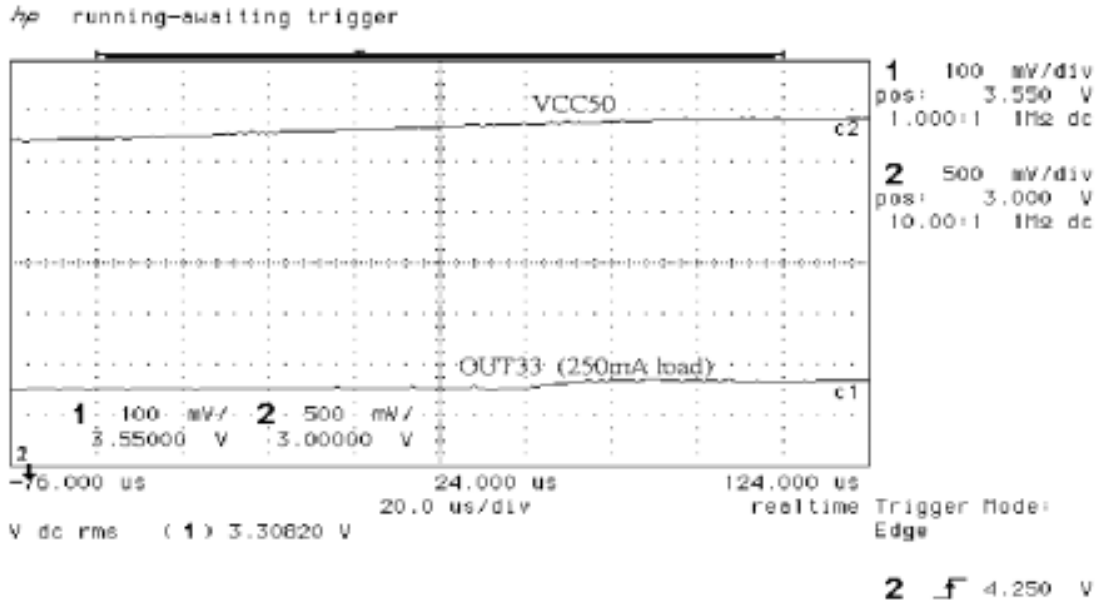

Figure 7. 3.3V VCC50 Power Up(AUX33=3.3V)

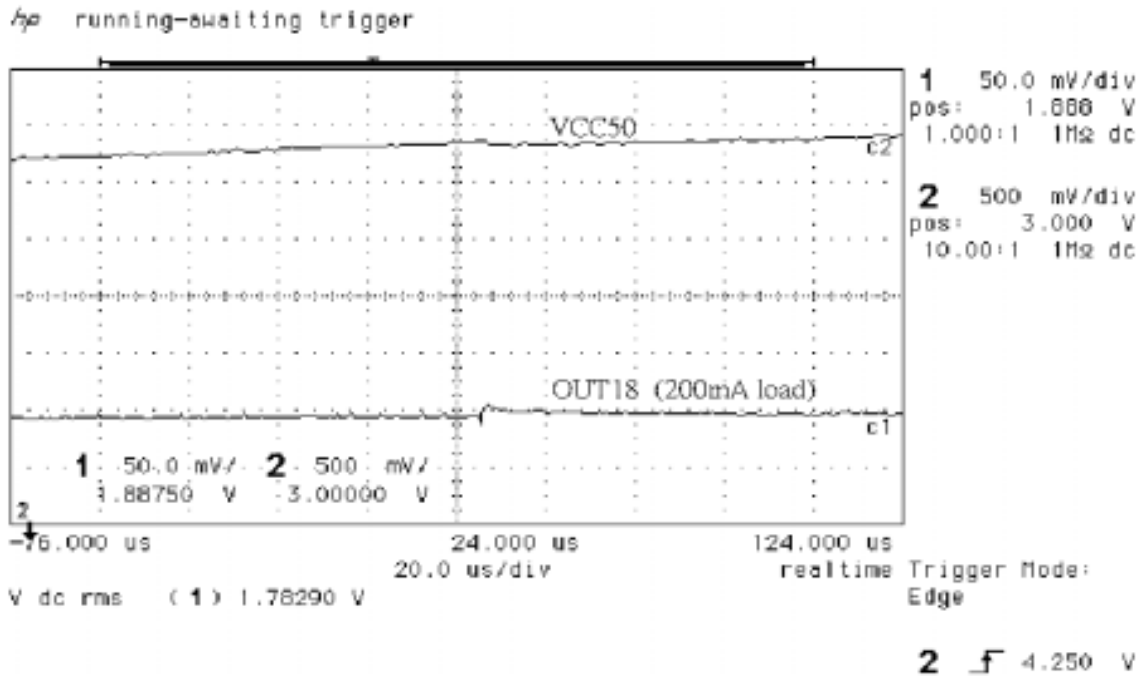

Figure 8. 1.8V VCC50 Power Up(AUX33=3.3V)



TYPICAL CHARACTERISTICS

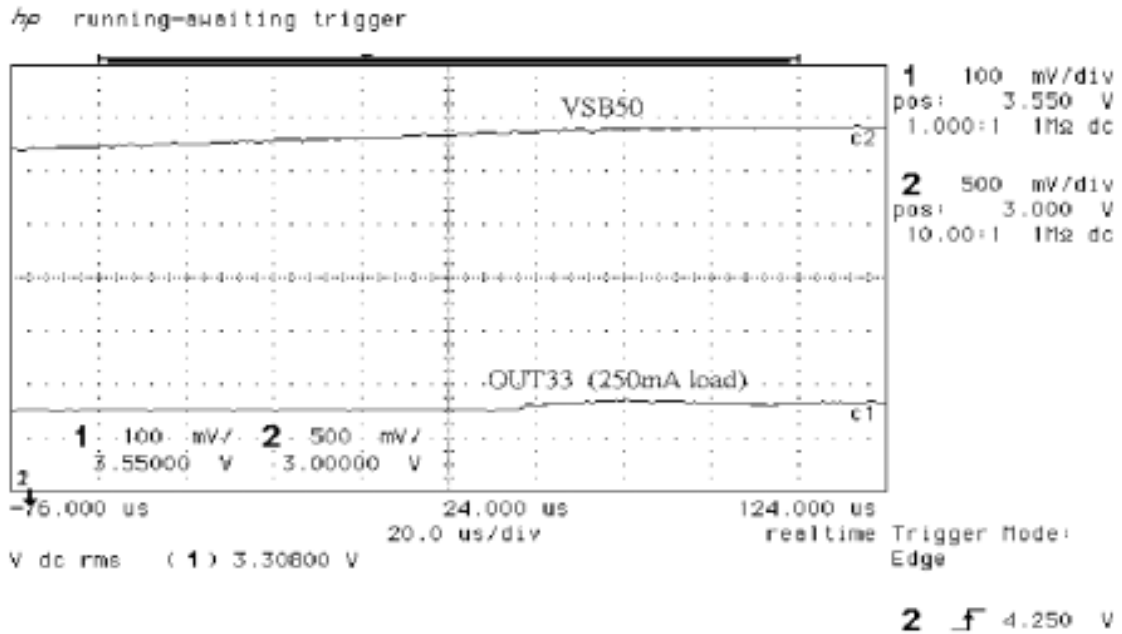

Figure 9. 3.3V VSB50 Power Up(AUX33=3.3V)

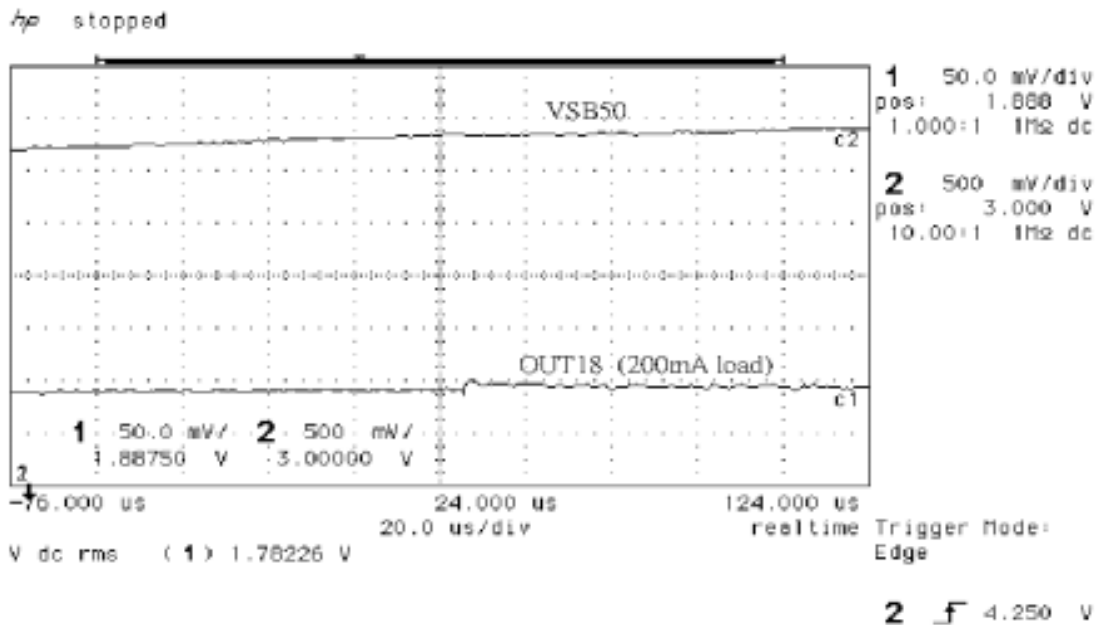

Figure 10. 1.8V VSB50 Power Up(AUX33=3.3V)



TYPICAL CHARACTERISTICS

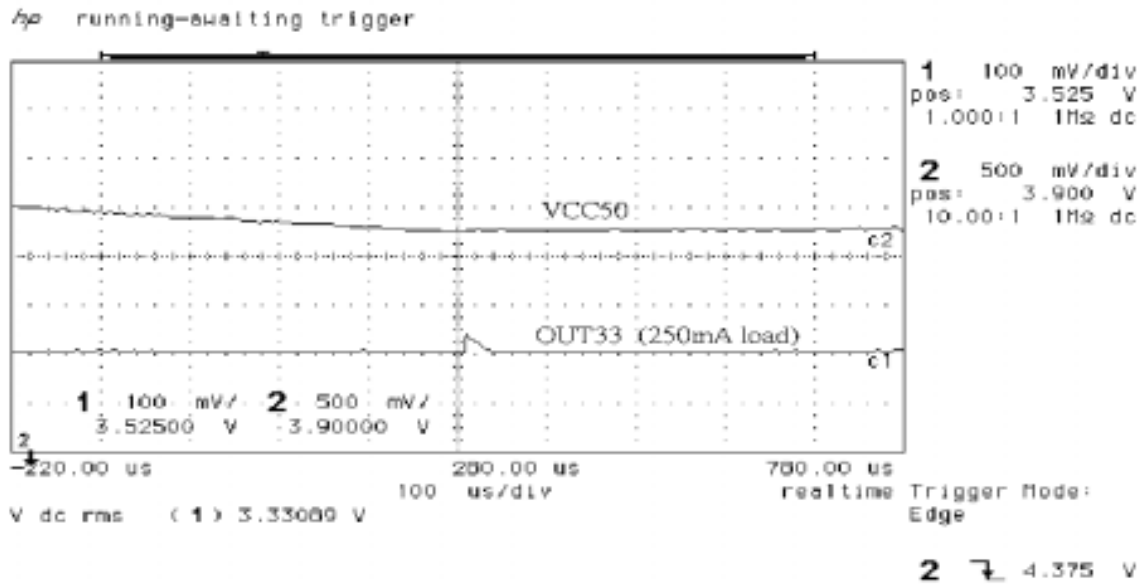

Figure 11. 3.3V VCC50 Power Down(VSB=5V)

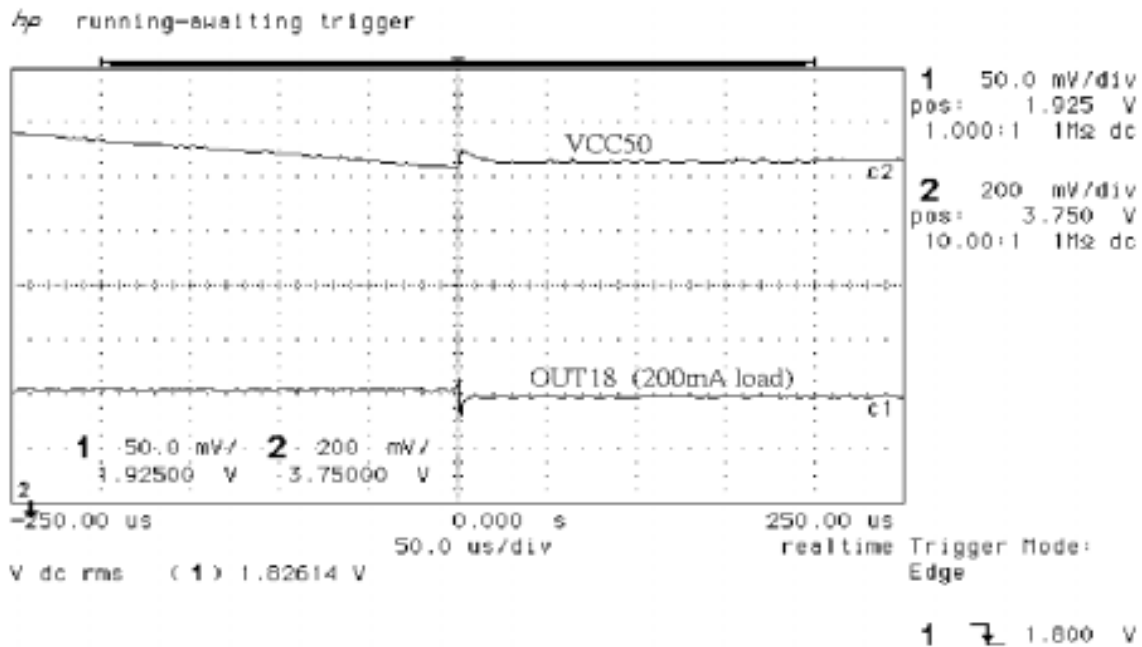

Figure 12. 1.8V VCC50 Power Down(VSB=5V)



TYPICAL CHARACTERISTICS

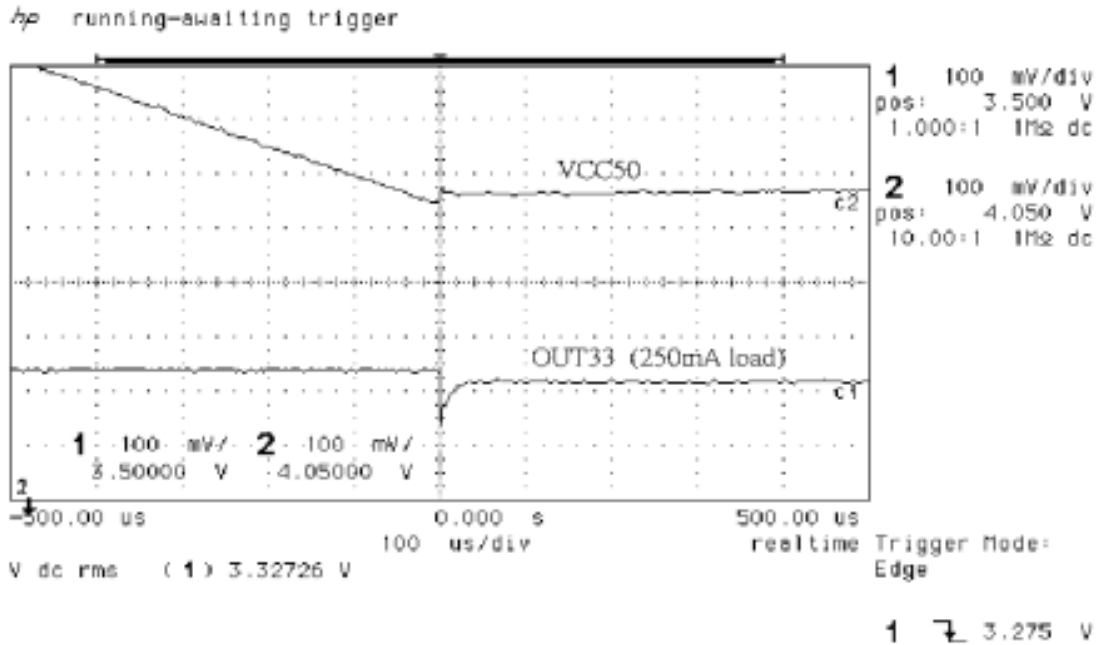

Figure 13. 3.3V VCC50 Power Down(AUX33=3.3V)

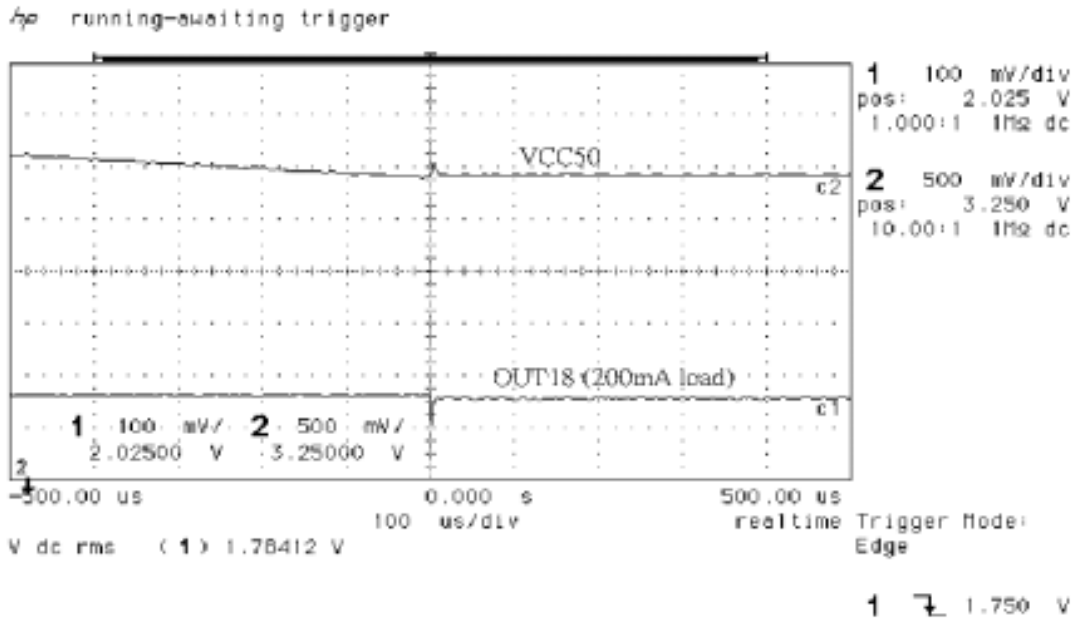

Figure 14. 1.8V VCC50 Power Down(AUX33=3.3V)



TYPICAL CHARACTERISTICS

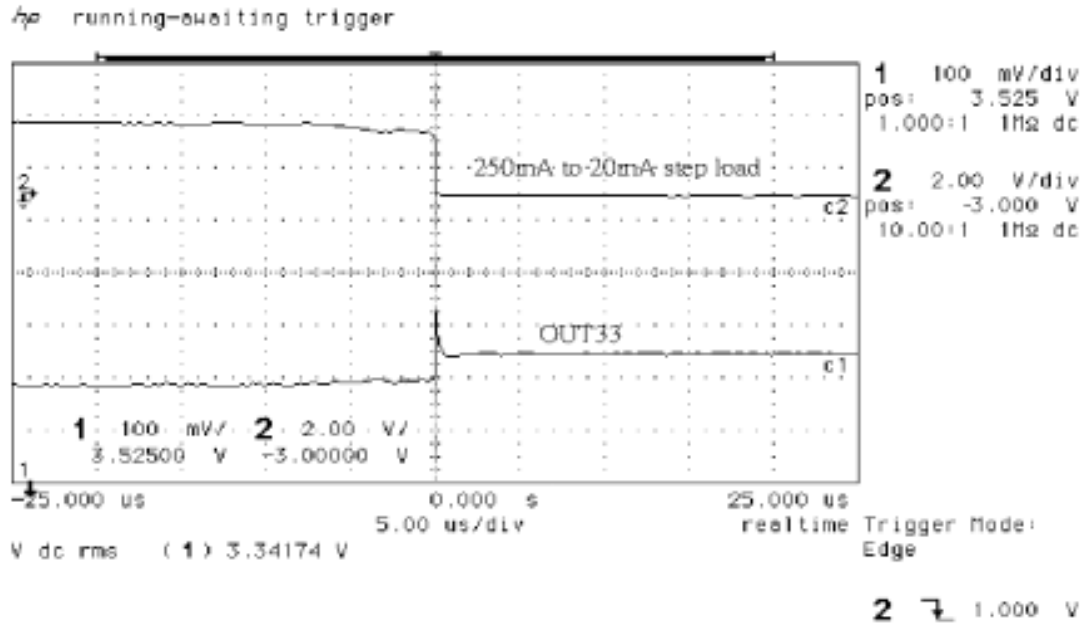

Figure 15. 3.3V Load Transient Response Falling.

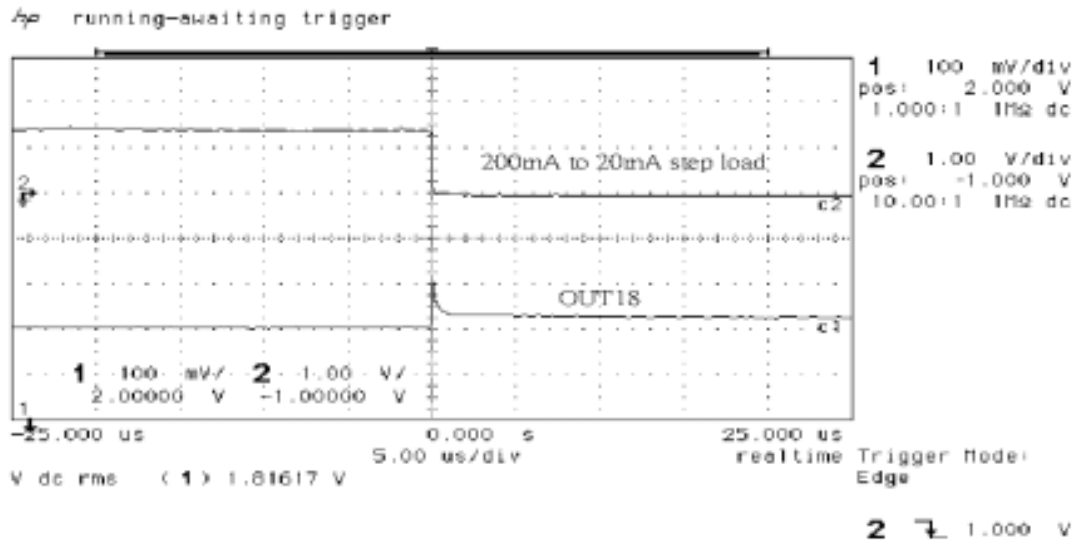

Figure 16. 1.8V Load Transient Response Falling.



TYPICAL CHARACTERISTICS

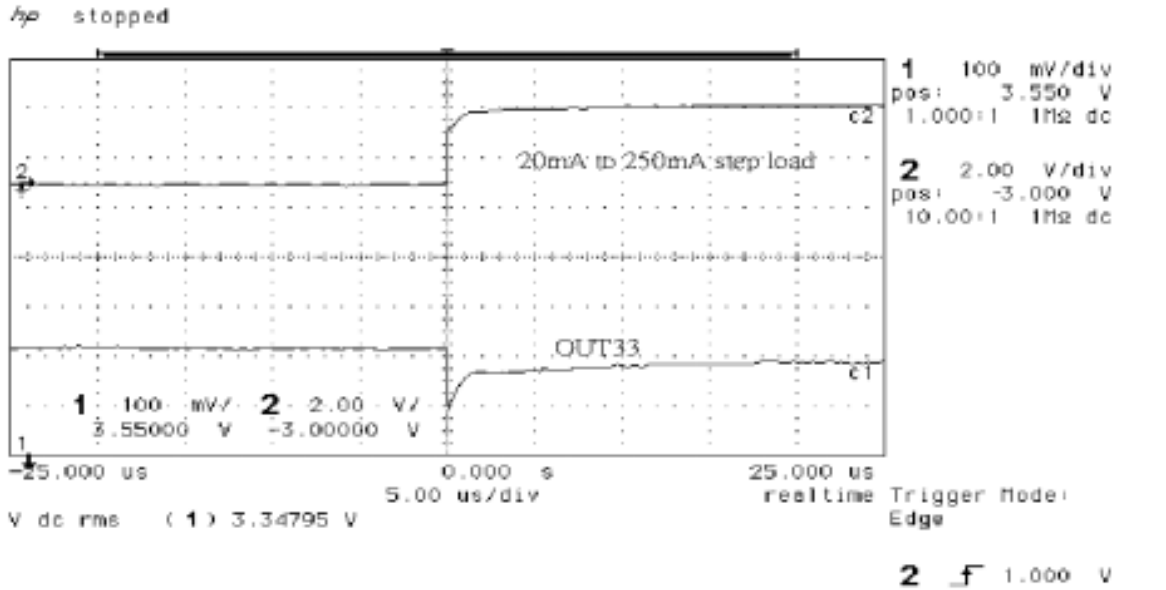

Figure 17. 3.3V Load Transient Response Rising

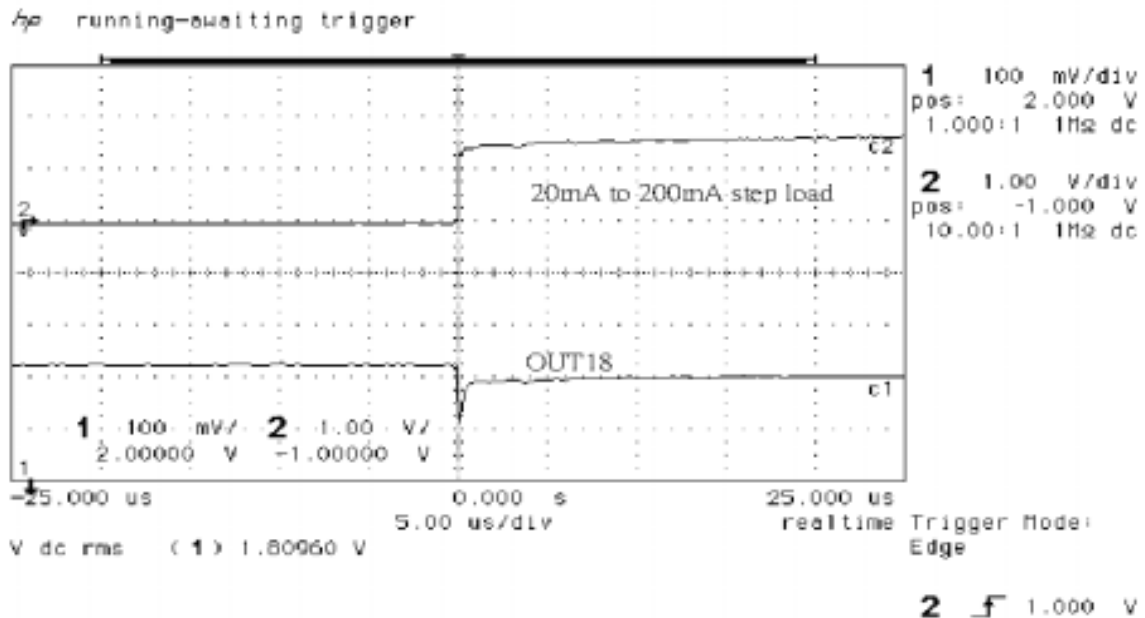

Figure 18. 1.8V Load Transient Response Rising

**THERMAL INFORMATION**

To ensure reliable operation of the device, the junction temperature of the output device must be within the safe operating area (SOA). This is achieved by having a means to dissipate the heat generated from the junction of the output structure. There are two components that contribute to thermal resistance. They consist of two paths in series. The first is the junction to case thermal resistance,  $R_{JC}$ ; the second is the case to ambient thermal resistance,  $R_{CA}$ . The overall junction to ambient thermal resistance,  $R_{JA}$ , is determined by :

$$R_{JA} = R_{JC} + R_{CA}$$

The ability to efficiently dissipate the heat from the junction is a function of the package style and board layout incorporated in the application. The operating junction temperature is determined by the operation ambient temperature,  $T_A$ , and the junction power dissipation,  $P_J$ .

The junction temperature,  $T_J$ , is equal to the following thermal equation :

$$T_J = T_A + P_J (R_{JC}) + P_J (R_{CA})$$

$$T_J = T_A + P_J (R_{JA})$$

This particular application uses the 8-pin SO package with standard lead frame with a dedicated ground terminal. Hence, the maximum power dissipation allowable for an operating ambient temperature of 70 °C, and a maximum junction temperature of 150 °C is determined as :

$$P_J = (T_J - T_A) / R_{JA}$$

$$P_J = (150 - 70) / 70 = 1.1W$$

Worst case maximum power dissipation is determined by :

$$P_D = (5.5 - 1.71) \times 0.25 = 0.9475W$$

Normal operating maximum power dissipation is :

$$P_D = (5 - 1.8) \times 0.25 = 0.8W$$

Note: The thermal characteristics of the AAT1202 were measured using a double-sided board with two square inches of copper area connected to the GND pins for "heat spreading". The use of multi-layer board construction with power planes will further enhance the thermal performance of the package.



**THERMAL INFORMATION**

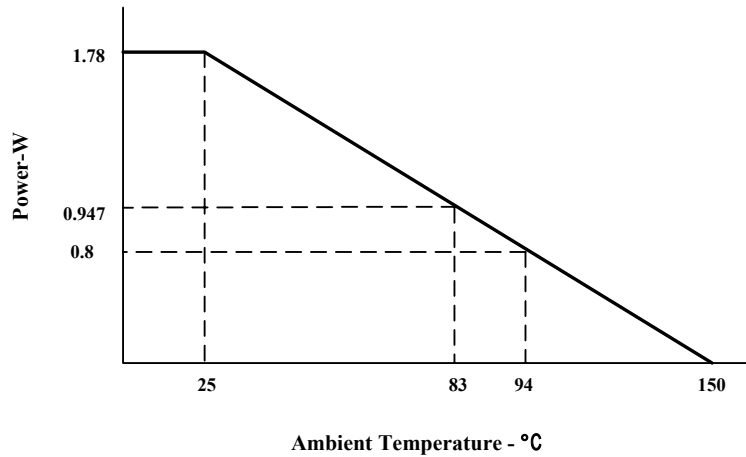

NOTE: These curves are to be used for guideline purposes only. For a particular application, a more specific thermal characterization is required.

**Power Dissipation Derating Curves**





APPLICATION INFORMATION

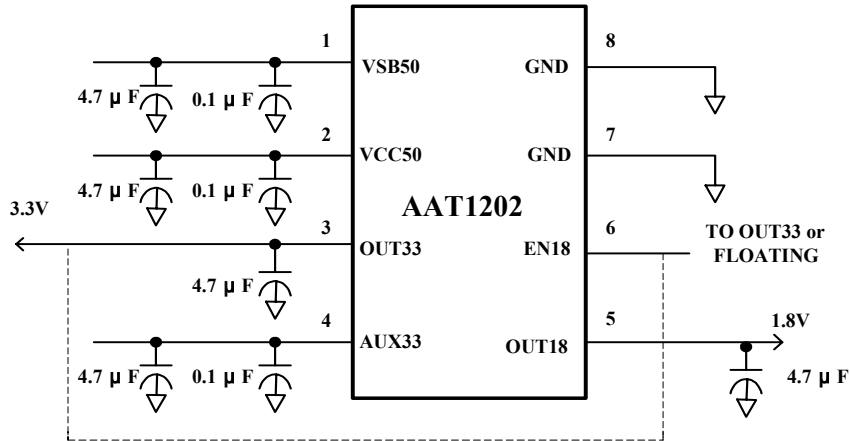

Typical Application Schematic - Dual Output

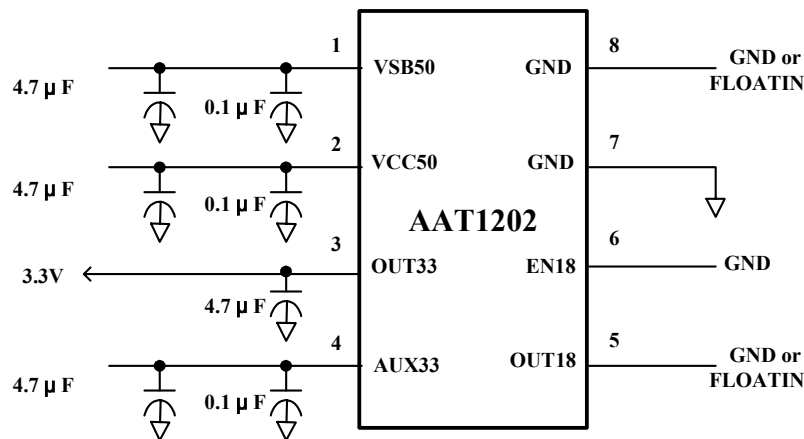

Typical Application Schematic - Only OUT33 Used



Package Dimension

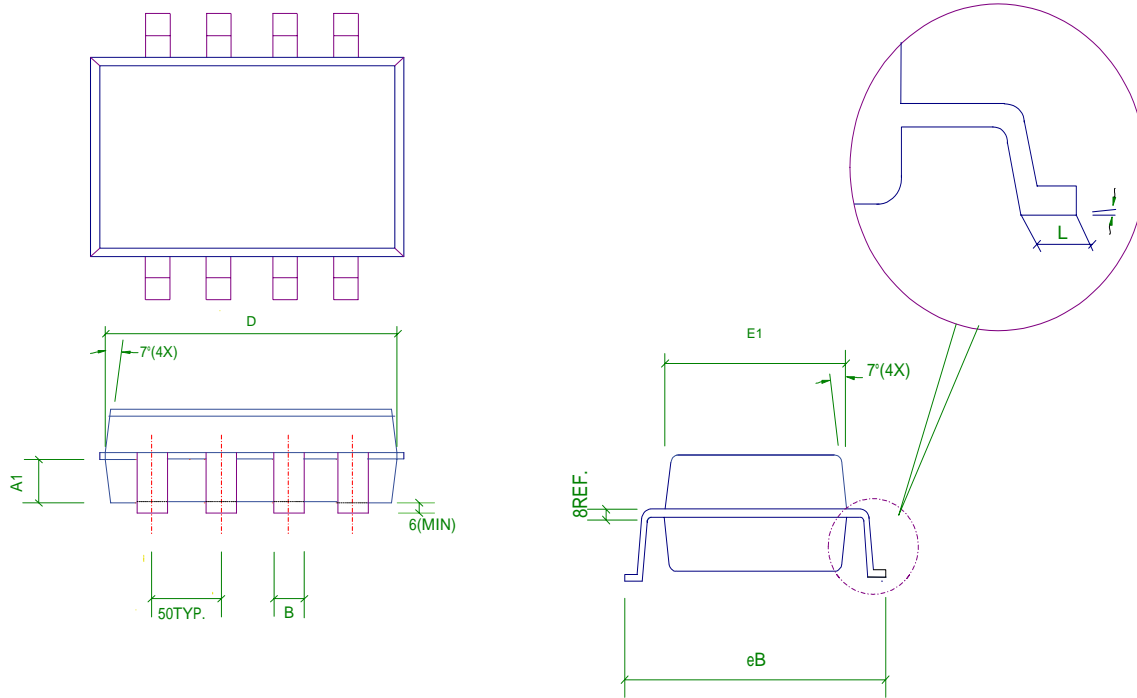

Symbol	Dimension in mils			Dimension in mm		
	Min	Nom	Max	Min	Nom	Max
A	59	63	67	1.498	1.600	1.702
A1	22	24	26	0.56	0.610	0.66
B	12	16	20	0.305	0.406	0.508
D	188	190	192	4.775	4.826	4.877
E1	152	154	156	3.861	3.912	3.962
eB	229	235	241	5.816	5.969	6.121
L	24	--	--	0.6	--	--
θ	0°	3°	6°	0°	3°	6°