

General Description

The AAT1155 SwitchReg™ is a member of AnalogicTech's Total Power Management IC™ (TPMIC™) product family. The step-down switching converter is ideal for applications where high efficiency, small size, and low ripple are critical. Able to deliver 2.5A with an internal power MOSFET, the current-mode controlled IC provides high efficiency. Fully internally compensated, the AAT1155 simplifies system design and lowers external parts count.

The AAT1155 is available in a Pb-free MSOP-8 package and is rated over the -40°C to +85°C temperature range.

Features

- 5.5V Max Supply Input
- Fixed or Adjustable V_{OUT} : 1.0V to 4.2V
- 2.5A Output Current
- Up to 95% Efficiency
- Integrated Low On Resistance Power Switches
- Internally Compensated Current Mode Control
- 1MHz Switching Frequency
- Constant PWM Mode
- Low Output Ripple With Light Load
- Internal Soft Start
- Current Limit Protection
- Over-Temperature Protection
- MSOP-8 Package
- -40°C to +85°C Temperature Range

Applications

- Cable/DSL Modems
- Computer Peripherals
- High Efficiency Conversion from 5V or 3.3V Supply
- Network Cards
- Set-Top Boxes

Typical Application

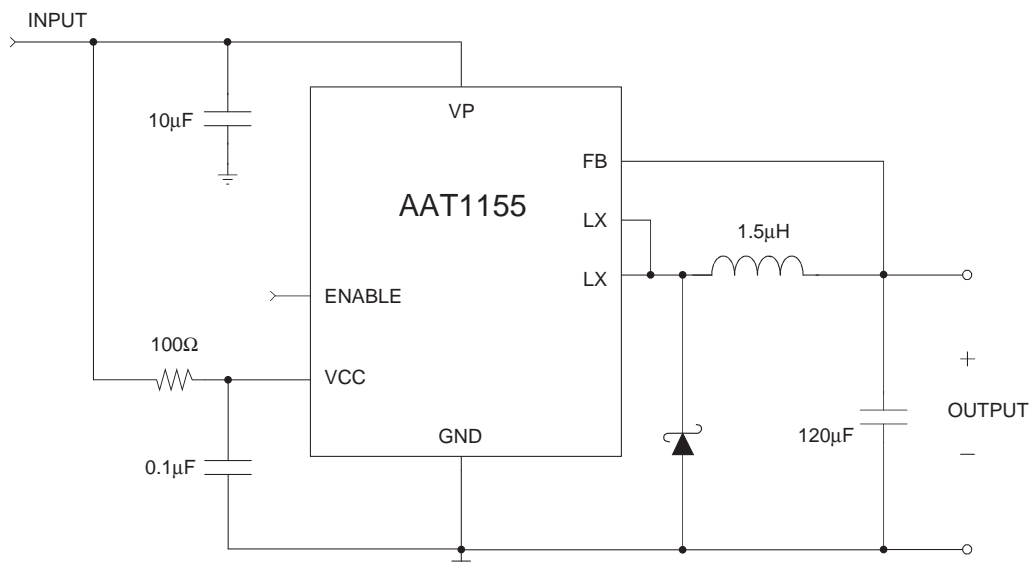

Pin Descriptions

Pin #	Symbol	Function
1	FB	Feedback input pin.
2	GND	Signal ground.
3	EN	Converter enable pin.
4	VCC	Small signal filtered bias supply.
5, 8	VP	Input supply for converter power stage.
6, 7	LX	Inductor connection pin.

Pin Configuration

MSOP-8

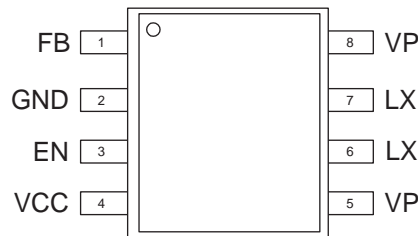

Absolute Maximum Ratings¹

$T_A = 25^\circ\text{C}$, unless otherwise noted.

Symbol	Description	Value	Units
V_{CC}, V_P	V_{CC}, V_P to GND	6	V
V_{LX}	LX to GND	-0.3 to $V_P+0.3$	V
V_{FB}	FB to GND	-0.3 to $V_{CC}+0.3$	V
V_{EN}	EN to GND	-0.3 to $V_{CC}+0.3$	V
T_J	Operating Junction Temperature Range	-40 to 150	$^\circ\text{C}$
T_{LEAD}	Maximum Soldering Temperature (at leads, 10 sec)	300	$^\circ\text{C}$
V_{ESD}	ESD Rating ² - HBM	3000	V

Thermal Characteristics³

Symbol	Description	Value	Units
Θ_{JA}	Maximum Thermal Resistance	150	$^\circ\text{C}/\text{W}$
P_D	Maximum Power Dissipation	833	mW

Recommended Operating Conditions

Symbol	Description	Rating	Units
T	Ambient Temperature Range	-40 to +85	$^\circ\text{C}$

1. Stresses above those listed in Absolute Maximum Ratings may cause permanent damage to the device. Functional operation at conditions other than the operating conditions specified is not implied. Only one Absolute Maximum Rating should be applied at any one time.
2. Human body model is a 100pF capacitor discharged through a 1.5k Ω resistor into each pin.
3. Mounted on a demo board (FR4, in still air).

Electrical Characteristics

$V_{IN} = V_{CC} = V_P = 5V$, $T_A = -40^{\circ}C$ to $+85^{\circ}C$, unless otherwise noted. Typical values are $T_A = 25^{\circ}C$.

Symbol	Description	Conditions	Min	Typ	Max	Units
V_{IN}	Input Voltage Range		2.7		5.5	V
V_{OUT}	Output Voltage Tolerance	$V_{IN} = V_{OUT} + 0.2$ to $5.5V$, $I_{OUT} = 0.5A$	-2.5		2.5	%
V_{IL}	Input Low Voltage				0.6	V
V_{IH}	Input High Voltage		1.4			V
V_{UVLO}	Under-Voltage Lockout	V_{IN} Rising			2.5	V
		V_{IN} Falling	1.2			
$V_{UVLO(HYS)}$	Under-Voltage Lockout Hysteresis			250		mV
I_Q	Quiescent Supply Current	No Load, $V_{FB} = 0V$		630	1000	μA
I_{SHDN}	Shutdown Current	$V_{EN} = 0V$, $V_{IN} = 5.5V$			1.0	μA
I_{LIM}	Current Limit	$T_A = 25^{\circ}C$	4.4			A
$R_{DS(ON)L}$	High Side Switch On Resistance	$T_A = 25^{\circ}C$		60		m Ω
η	Efficiency	$I_{OUT} = 1.0A$		92		%
$\Delta V_{OUT} (V_{OUT} * \Delta V_{IN})$	Load Regulation	$I_{LOAD} = 0A$ to $2.5A$		± 2.3		%
$\Delta V_{OUT}/V_{OUT}$	Line Regulation	$V_{IN} = 2.7V$ to $5.5V$		0.75		%/V
F_{OSC}	Oscillator Frequency	$T_A = 25^{\circ}C$		1		MHz
T_{SD}	Over-Temperature Shutdown Threshold			140		$^{\circ}C$
T_{HYS}	Over-Temperature Shutdown Hysteresis			15		$^{\circ}C$

Typical Characteristics

$R_{DS(ON)}$ vs. Temperature

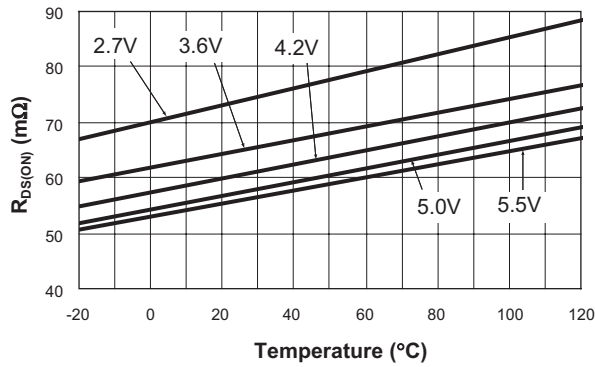

Oscillator Frequency Variation vs. Input Voltage
($V_{OUT} = 3.3V$)

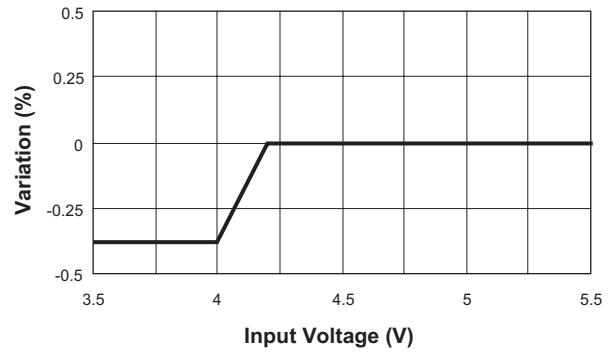

$R_{DS(ON)}$ vs. Input Voltage
($I_{DS} = 1A$)

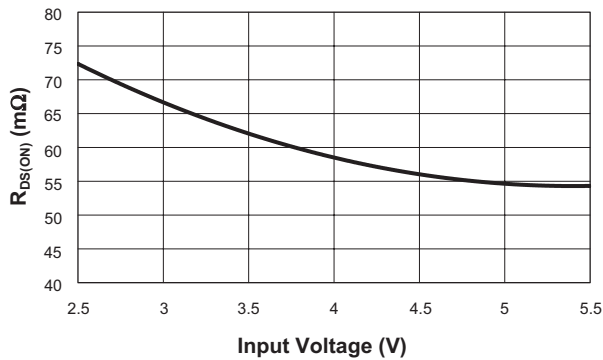

Oscillator Frequency Variation vs. Temperature
($V_{IN} = 5V$)

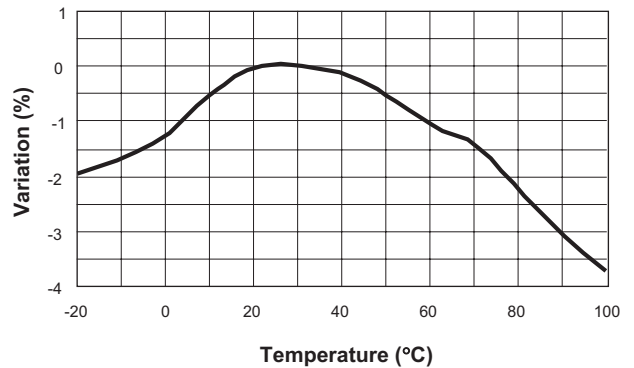

Enable Threshold vs. Input Voltage

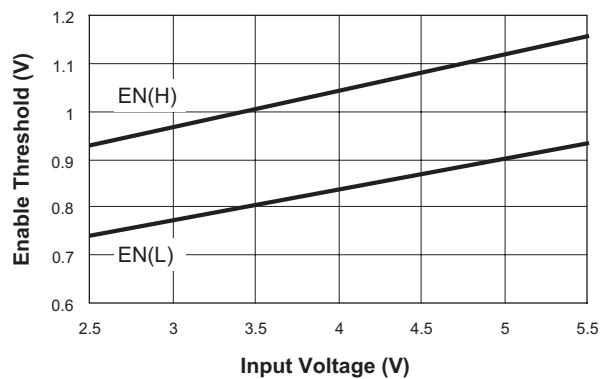

Output Voltage Variation vs. Temperature
($I_{OUT} = 2A$; $V_O = 3.3V$)

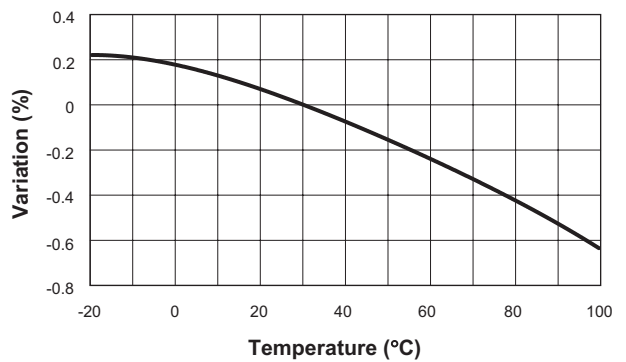

Typical Characteristics

Line Regulation
($V_{OUT} = 3.3V$)

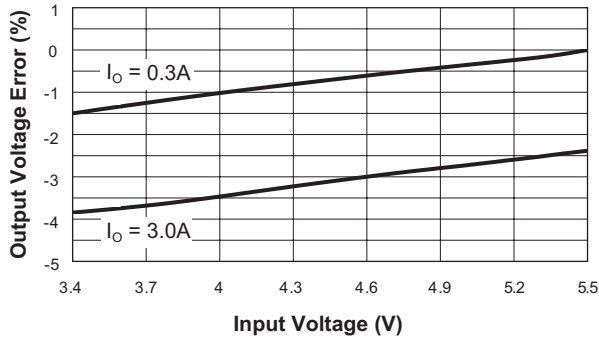

AAT1155 Evaluation Board
Over-Temperature Current vs. Input Voltage
($V_{OUT} = 3.3V$)

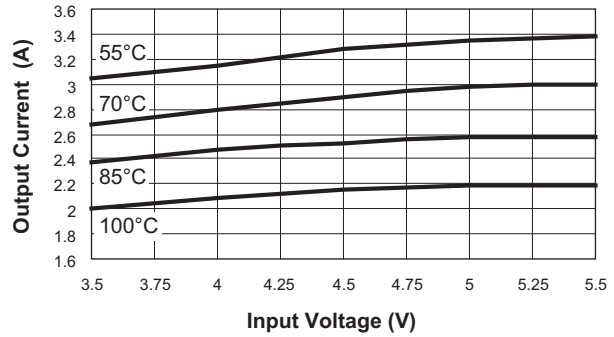

Load Regulation
($V_{IN} = 5.0V$; $V_{OUT} = 3.3V$)

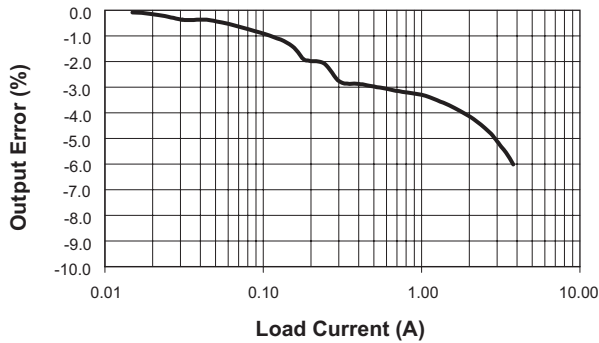

Non-Switching Operating
Current vs. Temperature
($FB = 0V$)

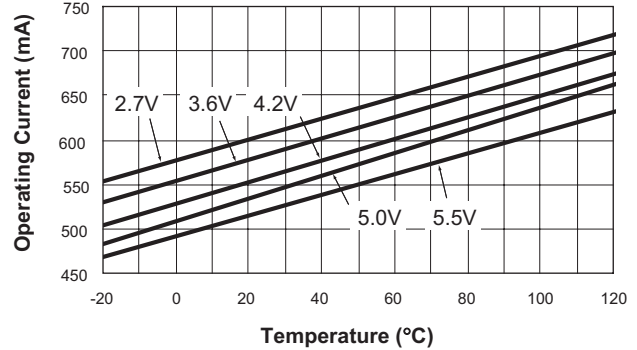

Over-Temperature Shutdown
Current vs. Temperature
($V_{OUT} = 3.3V$; $V_{IN} = 5.0V$)

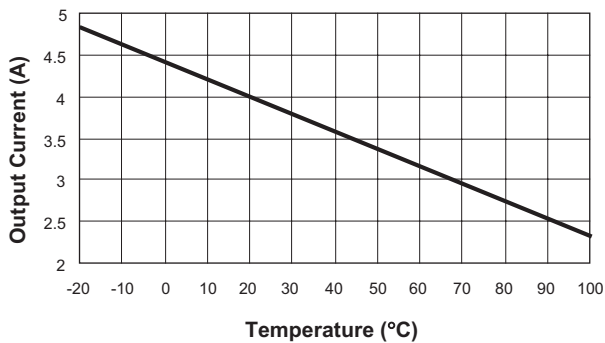

Inrush and Output
Overshoot Characteristics

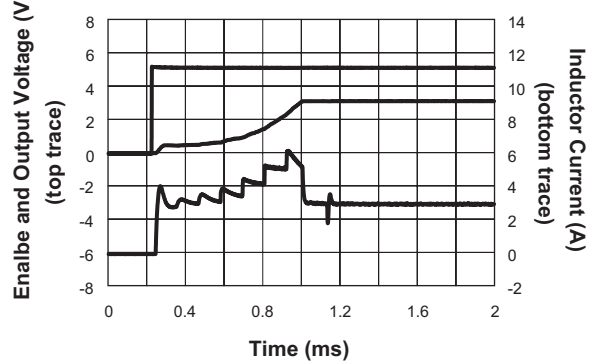

Typical Characteristics

Tantalum Output Ripple
 $(I_{OUT} = 3.0A; V_{OUT} = 3.3V; V_{IN} = 5.0V)$

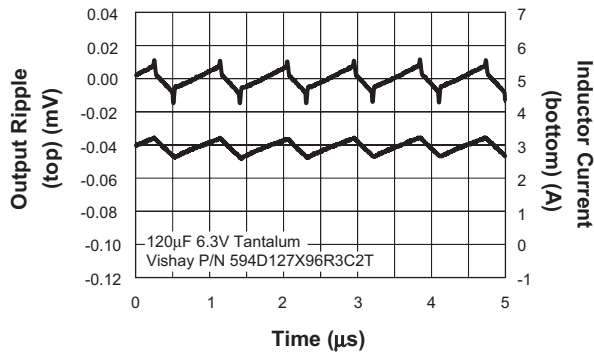

Loop Crossover Gain and Phase

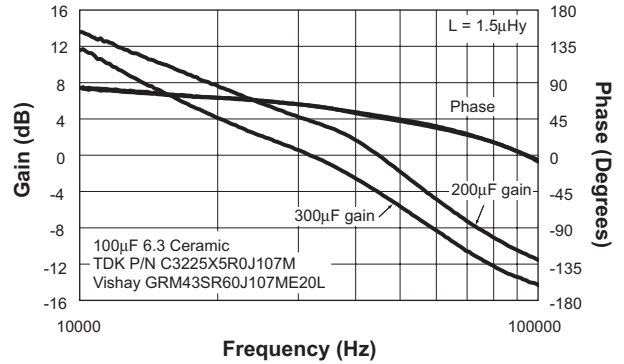

Output Ripple
 $(I_{OUT} = 3.0A; V_{OUT} = 3.3V; V_{IN} = 5.0V)$

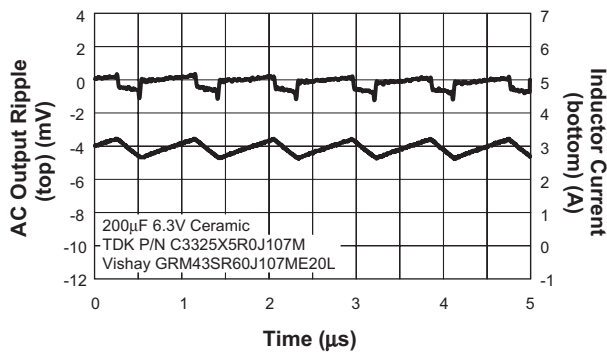

Loop Crossover Gain and Phase

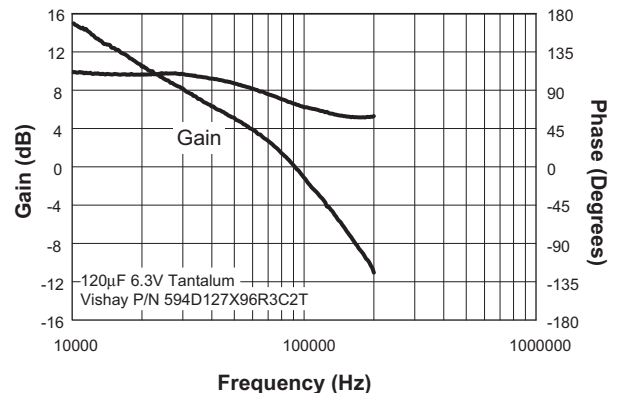

Output Ripple
 $(I_{OUT} = 3.0A; V_{OUT} = 3.3V; V_{IN} = 5.0V)$

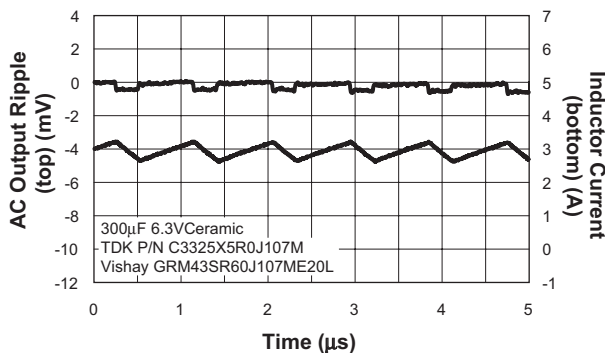

Tantalum Transient Response
 $(I_{OUT} = 0 \text{ to } 3.0A; V_{OUT} = 3.3V; V_{IN} = 5.0V)$

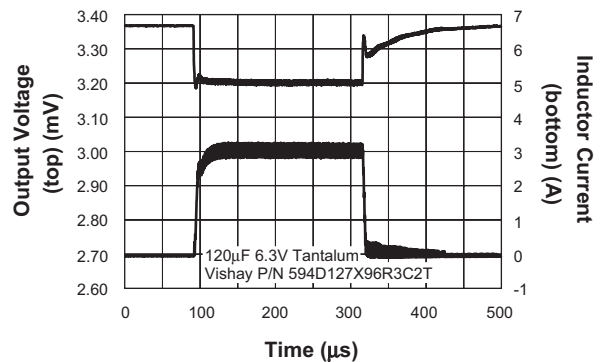

Typical Characteristics

Transient Response
($I_{OUT} = 0$ to $3.0A$; $V_{OUT} = 3.3V$; $V_{IN} = 5.0V$)

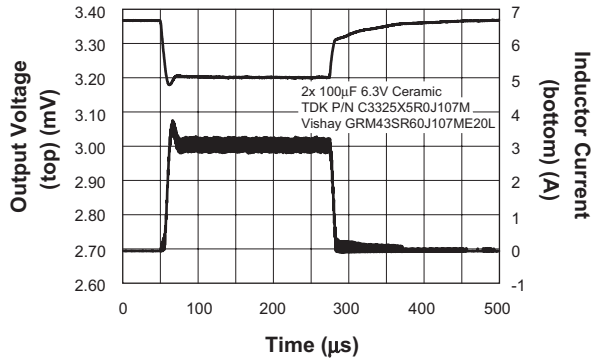

Transient Response
($I_{OUT} = 0$ to $3.0A$; $V_{OUT} = 3.3V$; $V_{IN} = 5.0V$)

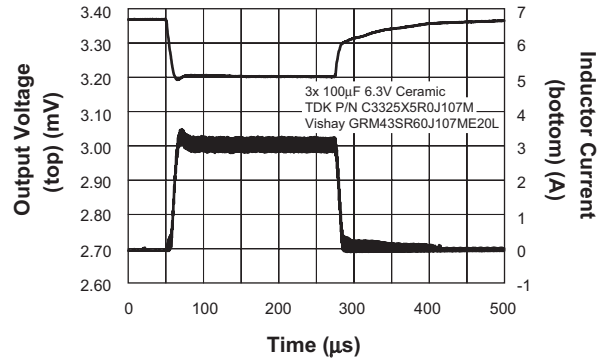

Functional Block Diagram

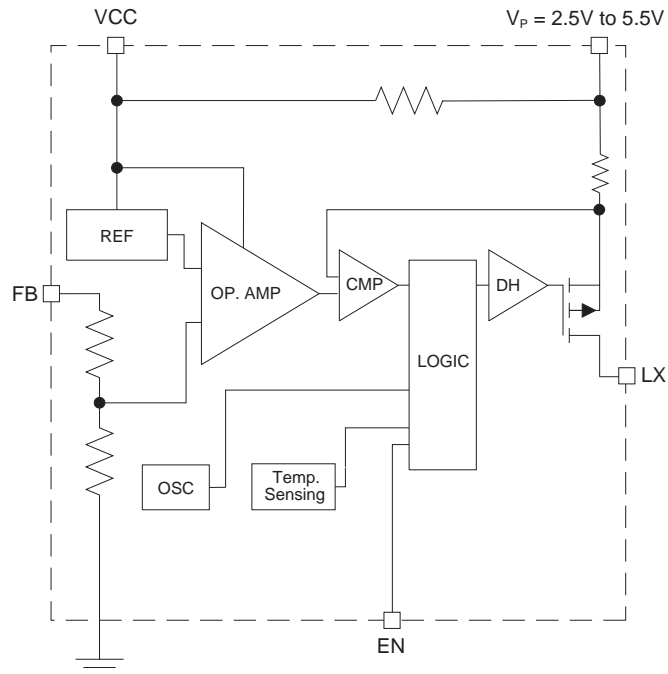

Applications Information

Main Control Loop

The AAT1155 is a peak current mode step-down converter. The inner wide bandwidth loop controls the inductor peak current. The inductor current is sensed as it flows through the internal P-channel MOSFET. A fixed slope compensation signal is then added to the sensed current to maintain stability for duty cycles greater than 50%. The inner loop appears as a voltage-programmed current source in parallel with the output capacitor.

The voltage error amplifier output programs the current loop for the necessary inductor current to force a constant output voltage for all load and line conditions. The feedback resistive divider is internal, dividing the output voltage to the error amplifier reference voltage of 1.0V. The error amplifier has a limited DC gain. This eliminates the need for external compensation components, while still providing sufficient DC loop gain for good load regulation. The crossover frequency and phase margin are set by the output capacitor value.

Duty cycle extends to 100% as the input voltage approaches the output voltage. Thermal shutdown protection disables the device in the event of a short-circuit or overload condition.

Soft Start/Enable

Soft start controls the current limit when the input voltage or enable is applied. It limits the current surge seen at the input and eliminates output voltage overshoot.

When pulled low, the enable input forces the device into a low-power, non-switching state. The total input current during shutdown is less than 1 μ A.

Power and Signal Source

Separate small signal ground and power supply pins isolate the internal control circuitry from switching noise. In addition, the low pass filter R1 and C3 (shown in Figure 1) filters noise associated with the power switching.

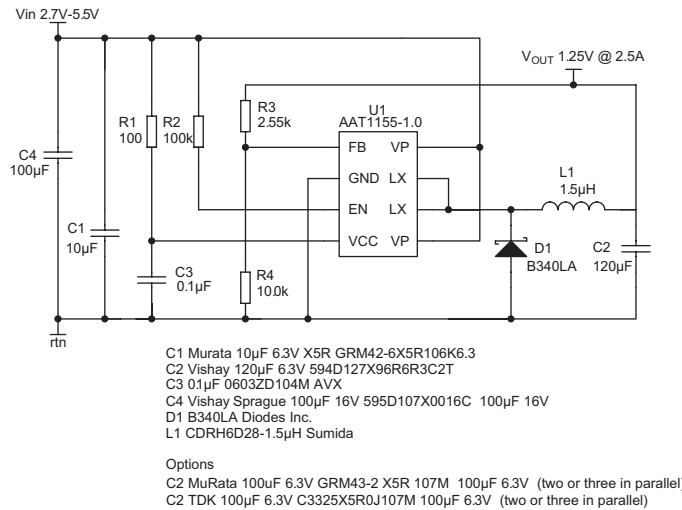

Figure 1: AAT1155 Evaluation Board with Adjustable Output.

Current Limit and Over-Temperature Protection

Over-temperature and current limit circuitry protects the AAT1155 and the external Schottky diode during overload, short-circuit, and excessive ambient temperature conditions. The junction over-temperature threshold is 140°C nominal and has 15°C of hysteresis. Typical graphs of the over-temperature load current vs. input voltage and ambient temperature are shown in the Typical Characteristics section of this document.

Inductor

The output inductor is selected to limit the ripple current to 20% to 40% of the full load current at the maximum input voltage. Manufacturer's specifications list both the inductor DC current rating, which is a thermal limitation, and the peak current rating, which is determined by the inductor saturation characteristics. The inductor should not show any appreciable saturation under normal load conditions. During overload and short-circuit conditions, the inductor can exceed its peak current rating without affecting the converter performance. Some inductors may have sufficient peak and average current ratings yet result in excessive losses due to a high DCR. The losses associated with the DCR and its effect on the total converter efficiency must be considered.

For a 2.5A load and the ripple current set to 40% at the maximum input voltage, the maximum peak-to-

peak ripple current is 1A. Assuming a 5V ±5% input voltage and 40% ripple, the output inductance required is:

$$\begin{aligned}
 L &= \frac{V_{OUT}}{I_{OUT} \cdot k \cdot F_{SW}} \cdot \left(1 - \frac{V_{OUT}}{V_{IN(MAX)}}\right) \\
 &= \left(\frac{3.3V}{2.5A \cdot 0.4 \cdot 1MHz}\right) \cdot 1 - \left(\frac{3.3V}{5.25V}\right) \\
 &= 1.23\mu H
 \end{aligned}$$

The factor "k" is the fraction of the full load (40%) selected for the ripple current at the maximum input voltage.

The corresponding inductor RMS current is:

$$I_{RMS} = \sqrt{\left(I_O^2 + \frac{\Delta I^2}{12}\right)} \approx I_O = 2.5A$$

ΔI is the peak-to-peak ripple current which is fixed by the inductor selection above. For a peak-to-peak current of 40% of the full load current, the peak current at full load will be 120% of the full load. The 1.5µH inductor selected from the Sumida CDRH6D38 series has a 11mΩ DCR and a 4.0A DC current rating with a height of 4mm. At full load, the inductor DC loss is 70mW for a 0.84% loss in efficiency.

A high ESR tantalum capacitor with a value about 10 times the input ceramic capacitor may also be required when using a 10µF or smaller ceramic input bypass capacitor. This dampens any input oscillations that may occur due to the source inductance resonating with the converter input impedance.

Output Capacitor

With no external compensation components, the output capacitor has a strong effect on the loop stability. Larger output capacitance will reduce the crossover frequency with greater phase margin. A 200µF ceramic capacitor provides sufficient bulk capacitance to stabilize the output during large load transitions and has ESR and ESL characteristics necessary for very low output ripple. The RMS ripple current is given by:

$$I_{RMS} = \frac{1}{2 \cdot \sqrt{3}} \cdot \frac{(V_{OUT} + V_{FWD}) \cdot (V_{IN} - V_{OUT})}{L \cdot F \cdot V_{IN}}$$

For a ceramic output capacitor, the dissipation due to the RMS current and associated output ripple are negligible.

Tantalum capacitors with sufficiently low ESR to meet output ripple requirements generally have an RMS current rating much greater than that actually seen in this application. The maximum tantalum output capacitor ESR is:

$$ESR \leq \frac{V_{RIPPLE}}{\Delta I}$$

where ΔI is the peak-to-peak inductor ripple current.

Due to the ESR zero associated with the tantalum capacitor, smaller values than those required with ceramic capacitors provide more phase margin with a greater loop crossover frequency.

Layout

Figures 3 and 4 display the suggested PCB layout for the AAT1155. The following guidelines should be used to help ensure a proper layout.

1. The connection from the input capacitor to the Schottky anode should be as short as possible.
2. The input capacitor should connect as closely as possible to V_P (Pins 5 and 8) and GND (Pin 2).
3. C1, L1, and CR1 should be connected as closely as possible. The connection from the cathode of the Schottky to the LX node should be as short as possible.
4. The feedback trace (Pin 1) should be separate from any power trace and connect as closely as possible to the load point. Sensing along a high-current load trace can degrade DC load regulation.
5. The resistance of the trace from the load return to the ground (Pin 2) should be kept to a minimum. This will help to minimize any error in DC regulation due to differences in the potential of the internal reference ground and the load return.
6. R1 and C3 are required in order to provide a cleaner power source for the AAT1155 control circuitry.

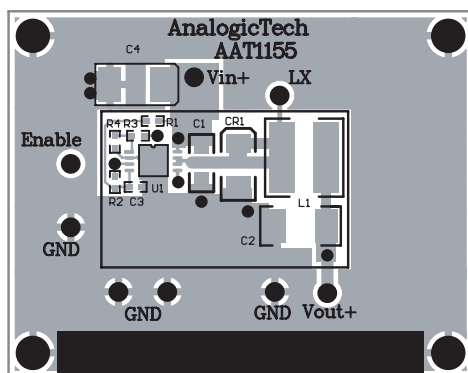

Figure 3: Evaluation Board Top Side.

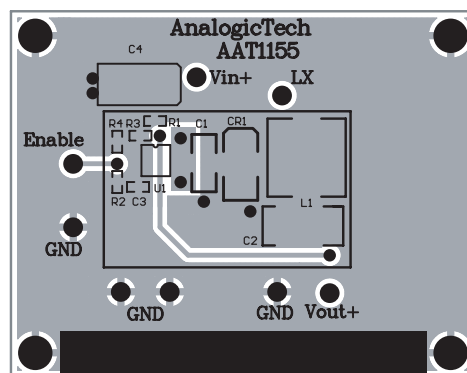

Figure 4: Evaluation Board Bottom Side.

Thermal

Losses associated with the AAT1155 output switching MOSFET are due to switching losses and conduction losses. The conduction losses are associated with the $R_{DS(ON)}$ characteristics of the output switching device. At the full load condition, assuming continuous conduction mode (CCM), an accurate calculation of the $R_{DS(ON)}$ losses can be derived from the following equations:

$$P_{ON} = I_{RMS}^2 \cdot R_{DS(ON)}$$

$R_{DS(ON)}$ losses

$$I_{RMS} = \sqrt{\left(I_O^2 + \frac{\Delta I^2}{12}\right) \cdot D}$$

Internal switch RMS current

D is the duty cycle and V_F is the forward voltage drop of the Schottky diode.

$$D = \frac{V_O + V_F}{V_{IN} + V_F}$$

ΔI is the peak-to-peak inductor ripple current.

A simplified form of calculating the $R_{DS(ON)}$ and switching losses is given by:

$$P = \frac{I_O^2 \cdot R_{DS(ON)} \cdot V_O}{V_{IN}} + t_{SW} \cdot F \cdot I_O + I_Q \cdot V_{IN}$$

where I_Q is the AAT1155 quiescent current.

Once the total losses have been determined, the junction temperature can be derived. The thermal resistance (Θ_{JA}) for the MSOP-8 package mounted on an FR4 printed circuit board in still air is 150°C/W.

$$T_J = P \cdot \Theta_{JA} + T_{AMB}$$

T_{AMB} is the maximum ambient temperature and T_J is the resultant maximum junction temperature.

Design Example

(see Figures 2 and 5 for reference)

I_{OUT}	2.5A
I_{RIPPLE}	40% of Full Load at Max V_{IN}
V_{OUT}	2.5V
V_{IN}	5V $\pm 5\%$
F_S	1MHz
T_{MAX}	70°C

Inductor Selection

$$L = \frac{V_{OUT}}{I_O \cdot k \cdot F} \cdot \left(1 - \frac{V_{OUT}}{V_{IN}}\right)$$

$$= \frac{3.3V}{2.5A \cdot 0.4 \cdot 1MHz} \cdot \left(1 - \frac{3.3V}{5.25V}\right) = 1.23\mu H$$

Use standard value of 1.5 μ H

Sumida inductor Series CDRH6D38.

$$\Delta I = \frac{V_O}{L \cdot F} \cdot \left(1 - \frac{V_O}{V_{IN}}\right) =$$

$$\frac{3.3V}{1.5\mu H \cdot 1MHz} \cdot \left(1 - \frac{3.3V}{5.25V}\right) = 0.82A$$

$$I_{PK} = I_{OUT} + \frac{\Delta I}{2} =$$

$$2.5A + 0.41 = 2.91A$$

Efficiency vs. Load Current

($V_{IN} = 5.0V$; $V_{OUT} = 3.3V$)

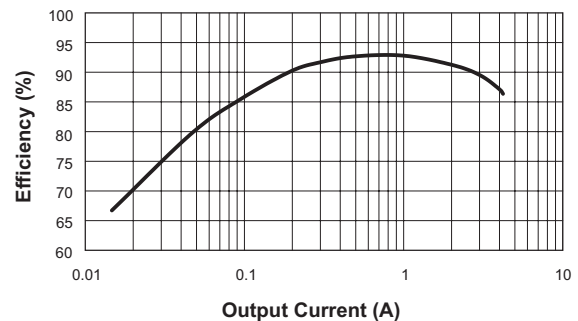

Figure 5: 5V Input, 3.3V Output.

AAT1155 Junction Temperature

$$P_{ON} = \frac{I_O^2 \cdot R_{DS(ON)} \cdot V_O}{V_{IN}} + \left(\frac{t_{SW} \cdot F \cdot I_O}{2} + I_Q \right) \cdot V_{IN} =$$

$$\frac{2.5^2 \cdot 70m\Omega \cdot 3.3V}{5V} + \left(\frac{20ns \cdot 1MHz \cdot 2.5A}{2} + 690\mu A \right)$$

0.42 Watts

$$T_{J(MAX)} = T_{AMB} + \theta_{JA} \cdot P =$$

$$70^\circ C + 150^\circ C/W \cdot 0.42W = 133^\circ C$$

Diode

$$I_{DIODE} = I_O \cdot \left(1 - \frac{V_O}{V_{IN}} \right) =$$

$$2.5A \cdot \left(1 - \frac{3.3V}{5.25V} \right) = 0.93A$$

$$V_{FW} = 0.35V$$

$$P_{DIODE} = V_{FW} \cdot I_{DIODE} =$$

$$0.35V \cdot 0.93A = 0.33A$$

Given an ambient thermal resistance of 120°C/W from the manufacturer's data sheet, $T_{J(MAX)}$ of the diode is:

$$T_{J(MAX)} = T_{AMB} + \theta_{JA} \cdot P =$$

$$70^\circ C + 120^\circ C/W \cdot 0.33W =$$

$$109^\circ C$$

Output Capacitor

The output capacitor value required for sufficient loop phase margin depends on the type of capacitor selected. For a low ESR ceramic capacitor, a minimum value of 200µF is required. For a low ESR tantalum capacitor, lower values are acceptable. While the relatively higher ESR associated with the tantalum capacitor will give more phase margin and a more dampened transient response, the output voltage ripple will be higher.

The 120µF Vishay 594D tantalum capacitor has an ESR of 85mΩ and a ripple current rating of 1.48Arms in a C case size. Although smaller case sizes are sufficiently rated for this ripple current, their ESR level would result in excessive output ripple.

The ESR requirement for a tantalum capacitor can be estimated by :

$$ESR \leq \frac{V_{RIPPLE}}{\Delta I} = \frac{100mV}{0.9A} = 111m\Omega$$

$$I_{RMS} = \frac{1}{2 \cdot \sqrt{3}} \cdot \frac{(V_{OUT} + V_{FWD}) \cdot (V_{IN} - V_{OUT})}{L \cdot F \cdot V_{IN}} =$$

$$\frac{1}{2 \cdot \sqrt{3}} \cdot \frac{3.65V \cdot 1.7V}{1.5\mu H \cdot 1MHz \cdot 5V} = 240mArms$$

Two or three 1812 X5R 100µF 6.3V ceramic capacitors in parallel also provide sufficient phase margin. The low ESR and ESL associated with ceramic capacitors also reduces output ripple significantly over that seen with tantalum capacitors. Temperature rise due to ESR ripple current dissipation is also reduced.

Input Capacitor

The input capacitor ripple is:

$$I_{RMS} = I_O \cdot \sqrt{\frac{V_O}{V_{IN}} \cdot \left(1 - \frac{V_O}{V_{IN}} \right)} = 1.82Arms$$

In the examples shown, C1 is a ceramic capacitor located as closely to the IC as possible. C1 provides the low impedance path for the sharp edges associated with the input current. C4 may or may not be required, depending upon the impedance characteristics looking back into the source. It serves to dampen any input oscillations that may arise from a source that is highly inductive. For most applications, where the source has sufficient bulk capacitance and is fed directly to the AAT1155 through large PCB traces or planes, it is not required. When operating the AAT1155 evaluation board on the bench, C4 is required due to the inductance of the wires running from the laboratory power supply to the evaluation board.

Adjustable Output

For applications requiring an output other than the fixed outputs available, the 1V version can be programmed externally. Resistors R3 and R4 of Figure 1 force the output to regulate higher than

1 volt. For accurate results (less than 1% error for all outputs), select R4 to be 10kΩ. Once R4 has been selected, R3 can be calculated. For a 1.25 volt output with R4 set to 10kΩ, R3 is 2.5kΩ.

$$R3 = (V_O - 1) \cdot R4 = 0.25 \cdot 10k\Omega = 2.5k\Omega$$

Capacitors

Part Number	Manufacturer	Capacitance (μF)	Voltage (V)	Temp Co.	Case
C4532X5ROJ107M	TDK	100	6.3	X5R	1812
GRM43-2 X5R 107M 6.3	MuRata	100	6.3	X5R	1812
GRM43-2 X5R 476K 6.3	MuRata	47	6.3	X5R	1812
GRM42-6 X5R 106K 6.3	MuRata	10	6.3	X5R	1206
594D127X_6R3C2T	Vishay	120	6.3		C
595D107X0016C	Vishay	100	16		C

Inductors

Part Number	Manufacturer	Inductance (μH)	I (Amps)	DCR (Ω)	Height (mm)	Type
CDRH6D38-4763-T055	Sumida	1.5	4.0	0.014	4.0	Shielded
N05D B1R5M	Taiyo Yuden	1.5	3.2	0.025	2.8	Non-Shielded
NP06DB B1R5M	Taiyo Yuden	1.5	3.0	0.022	3.2	Shielded
LQH55DN1R5M03	MuRata	1.5	3.7	0.022	4.7	Non-Shielded
LQH66SN1R5M03	MuRata	1.5	3.8	0.016	4.7	Shielded

Diodes

Manufacturer	Part Number	V _F
Diodes Inc.	B340LA	0.45V @ 3A
ROHM	RB050L-40	0.45 @ 3A
Micro Semi	5820SM	0.46V @ 3A

© Advanced Analogic Technologies, Inc.

AnalogicTech cannot assume responsibility for use of any circuitry other than circuitry entirely embodied in an AnalogicTech product. No circuit patent licenses, copyrights, mask work rights, or other intellectual property rights are implied. AnalogicTech reserves the right to make changes to their products or specifications or to discontinue any product or service without notice. Customers are advised to obtain the latest version of relevant information to verify, before placing orders, that information being relied on is current and complete. All products are sold subject to the terms and conditions of sale supplied at the time of order acknowledgement, including those pertaining to warranty, patent infringement, and limitation of liability. AnalogicTech warrants performance of its semiconductor products to the specifications applicable at the time of sale in accordance with AnalogicTech's standard warranty. Testing and other quality control techniques are utilized to the extent AnalogicTech deems necessary to support this warranty. Specific testing of all parameters of each device is not necessarily performed.

Advanced Analogic Technologies, Inc.
830 E. Arques Avenue, Sunnyvale, CA 94085
Phone (408) 737-4600
Fax (408) 737-4611