

Silicon NPN Planar RF Transistor

Electrostatic sensitive device.
Observe precautions for handling.



Applications

Wide band amplifier up to GHz range.

Features

- High power gain
- High transition frequency
- Low noise figure

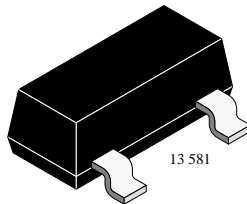
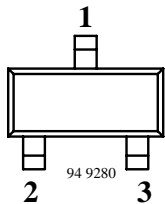

BFR93A Marking: +R2
Plastic case (SOT 23)
1 = Collector, 2 = Base, 3 = Emitter

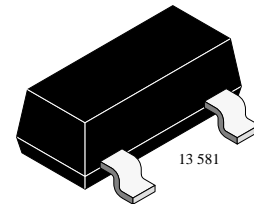
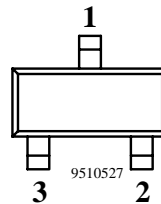

BFR93AR Marking: +R5
Plastic case (SOT 23)
1 = Collector, 2 = Base, 3 = Emitter

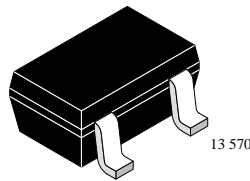
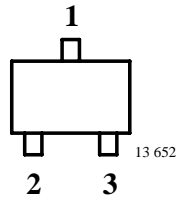

BFR93AW Marking: WR2
Plastic case (SOT 323)
1 = Collector, 2 = Base, 3 = Emitter

Absolute Maximum Ratings

$T_{amb} = 25^{\circ}\text{C}$, unless otherwise specified

Parameter	Test Conditions	Symbol	Value	Unit
Collector-base voltage		V_{CBO}	20	V
Collector-emitter voltage		V_{CEO}	12	V
Emitter-base voltage		V_{EBO}	2	V
Collector current		I_C	50	mA
Total power dissipation	$T_{amb} \leq 60^{\circ}\text{C}$	P_{tot}	200	mW
Junction temperature		T_j	150	$^{\circ}\text{C}$
Storage temperature range		T_{stg}	-65 to +150	$^{\circ}\text{C}$

Maximum Thermal Resistance

$T_{amb} = 25^{\circ}\text{C}$, unless otherwise specified

Parameter	Test Conditions	Symbol	Value	Unit
Junction ambient	on glass fibre printed board (25 x 20 x 1.5) mm ³ plated with 35μm Cu	R_{thJA}	450	K/W

Electrical DC Characteristics

$T_{amb} = 25^{\circ}\text{C}$, unless otherwise specified

Parameter	Test Conditions	Symbol	Min	Typ	Max	Unit
Collector cut-off current	$V_{CE} = 20\text{ V}$, $V_{BE} = 0$	I_{CES}			100	μA
Collector-base cut-off current	$V_{CB} = 10\text{ V}$, $I_E = 0$	I_{CBO}			100	nA
Emitter-base cut-off current	$V_{EB} = 2\text{ V}$, $I_C = 0$	I_{EBO}			10	μA
Collector-emitter breakdown voltage	$I_C = 1\text{ mA}$, $I_B = 0$	$V_{(BR)CEO}$	12			V
Collector-emitter saturation voltage	$I_C = 50\text{ mA}$, $I_B = 5\text{ mA}$	V_{CEsat}		0.1	0.4	V
DC forward current transfer ratio	$V_{CE} = 5\text{ V}$, $I_C = 30\text{ mA}$	h_{FE}	40	90	150	

Electrical AC Characteristics

$T_{amb} = 25^{\circ}\text{C}$, unless otherwise specified

Parameter	Test Conditions	Symbol	Min	Typ	Max	Unit
Transition frequency	$V_{CE} = 5\text{ V}$, $I_C = 30\text{ mA}$, $f = 500\text{ MHz}$	f_T		6		GHz
Collector-base capacitance	$V_{CB} = 10\text{ V}$, $f = 1\text{ MHz}$	C_{cb}		0.45		pF
Collector-emitter capacitance	$V_{CE} = 5\text{ V}$, $f = 1\text{ MHz}$	C_{ce}		0.2		pF
Emitter-base capacitance	$V_{EB} = 0.5\text{ V}$, $f = 1\text{ MHz}$	C_{eb}		1.5		pF
Noise figure	$V_{CE} = 8\text{ V}$, $Z_S = 50\ \Omega$, $f = 800\text{ MHz}$, $I_C = 5\text{ mA}$	F		1.6		dB
	$V_{CE} = 8\text{ V}$, $Z_S = 50\ \Omega$, $f = 800\text{ MHz}$, $I_C = 25\text{ mA}$	F		2.1		dB
Power gain	$V_{CE} = 8\text{ V}$, $I_C = 25\text{ mA}$, $Z_S = 50\ \Omega$, $Z_L = Z_{Lopt}$, $f = 800\text{ MHz}$	G_{pe}		14		dB
Linear output voltage – two tone intermodulation test	$V_{CE} = 8\text{ V}$, $I_C = 25\text{ mA}$, $d_{IM} = 60\text{ dB}$, $f_1 = 806\text{ MHz}$, $f_2 = 810\text{ MHz}$, $Z_S = Z_L = 50\ \Omega$	$V_1 = V_2$		260		mV
Third order intercept point	$V_{CE} = 8\text{ V}$, $I_C = 25\text{ mA}$, $f = 800\text{ MHz}$	IP_3		31		dBm



Common Emitter S-Parameters

$Z_0 = 50 \Omega$, $T_{amb} = 25^\circ\text{C}$, unless otherwise specified

V_{CE}/V	I_C/mA	f/MHz	S11		S21		S12		S22	
			LIN MAG	ANG	LIN MAG	ANG	LIN MAG	ANG	LIN MAG	ANG
				deg		deg		deg		deg
8	5	100	0.811	-33.9	12.66	152.2	0.028	72.8	0.914	-15.0
		300	0.530	-83.4	8.32	117.3	0.058	57.8	0.661	-27.4
		500	0.370	-116.3	5.67	99.8	0.075	56.7	0.537	-26.9
		800	0.274	-149.7	3.77	85.0	0.099	59.8	0.487	-23.8
		1000	0.256	-165.5	3.11	77.8	0.117	61.8	0.485	-24.2
		1200	0.255	-178.6	2.67	71.1	0.135	62.6	0.481	-26.8
		1500	0.277	162.7	2.21	62.1	0.163	63.3	0.466	-31.3
		1800	0.294	146.0	1.91	54.0	0.194	63.3	0.455	-35.0
		2000	0.312	136.2	1.76	49.4	0.215	62.7	0.454	-38.4
	10	100	0.676	-44.9	19.22	142.3	0.025	69.9	0.832	-21.0
		300	0.377	-97.1	10.24	108.0	0.050	62.8	0.539	-29.0
		500	0.259	-131.0	6.59	93.8	0.071	64.8	0.441	-25.0
		800	0.197	-164.2	4.26	81.6	0.102	66.9	0.415	-20.4
		1000	0.189	-178.0	3.48	75.4	0.124	67.2	0.423	-21.1
		1200	0.195	169.8	2.98	69.5	0.147	66.7	0.424	-24.2
		1500	0.222	155.6	2.46	61.4	0.179	65.4	0.409	-29.0
		1800	0.245	140.0	2.12	54.1	0.212	63.6	0.398	-32.6
		2000	0.263	131.3	1.95	49.9	0.235	62.0	0.397	-36.2
	15	100	0.597	-52.0	22.81	136.3	0.023	69.3	0.774	-23.9
		300	0.306	-105.2	10.94	103.8	0.047	66.5	0.484	-28.5
		500	0.219	-139.3	6.91	91.3	0.070	68.4	0.405	-23.3
		800	0.172	-172.8	4.45	80.0	0.104	69.5	0.390	-18.3
		1000	0.165	174.6	3.62	74.3	0.128	69.0	0.401	-19.4
		1200	0.174	164.9	3.09	68.8	0.151	68.1	0.403	-22.7
1500		0.201	152.9	2.54	61.0	0.185	66.0	0.388	-27.8	
1800		0.226	137.5	2.19	53.9	0.219	63.8	0.377	-31.4	
2000		0.245	128.5	2.01	49.7	0.243	61.8	0.375	-35.3	

BFR93A/BFR93AR/BFR93AW



Vishay Semiconductors

V _{CE} /V	I _C /mA	f/MHz	S11		S21		S12		S22	
			LIN MAG	ANG	LIN MAG	ANG	LIN MAG	ANG	LIN MAG	ANG
				deg		deg		deg		deg
8	20	100	0.540	-56.8	24.86	132.3	0.022	68.6	0.732	-25.5
		300	0.274	-110.3	11.22	101.5	0.046	68.6	0.455	-27.6
		500	0.199	-144.7	7.03	89.8	0.070	70.5	0.387	-21.9
		800	0.164	-177.3	4.49	79.2	0.105	70.9	0.380	-16.9
		1000	0.160	171.1	3.66	73.5	0.130	70.1	0.391	-18.2
		1200	0.166	162.3	3.13	68.2	0.153	68.6	0.393	-21.8
		1500	0.197	151.6	2.58	60.5	0.188	66.2	0.378	-27.1
		1800	0.223	135.8	2.21	53.7	0.222	63.8	0.367	-30.9
		2000	0.242	128.2	2.04	49.5	0.246	61.8	0.365	-34.7
	25	100	0.502	-61.1	26.06	129.3	0.021	68.7	0.702	-26.4
		300	0.254	-114.6	11.32	99.8	0.045	69.6	0.438	-26.5
		500	0.191	-148.9	7.05	88.8	0.070	71.5	0.378	-20.6
		800	0.162	178.0	4.51	78.5	0.106	71.5	0.374	-16.0
		1000	0.158	167.6	3.66	73.0	0.131	70.5	0.387	-17.5
		1200	0.163	159.3	3.13	67.6	0.154	69.0	0.389	-21.2
		1500	0.200	149.0	2.57	60.1	0.190	66.4	0.374	-26.6
		1800	0.220	134.7	2.21	53.2	0.224	63.8	0.364	-30.5
		2000	0.243	128.4	2.04	48.9	0.248	61.7	0.361	-34.4

Typical Characteristics ($T_{amb} = 25^{\circ}\text{C}$ unless otherwise specified)

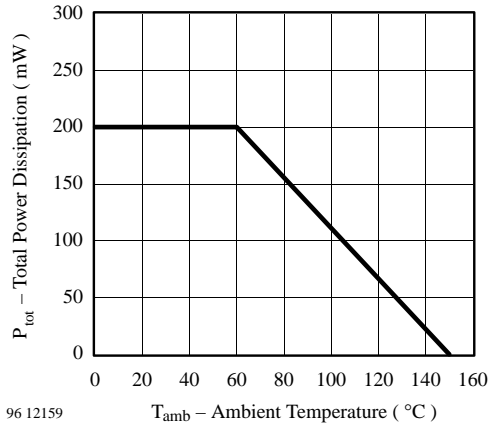

Figure 1. Total Power Dissipation vs. Ambient Temperature

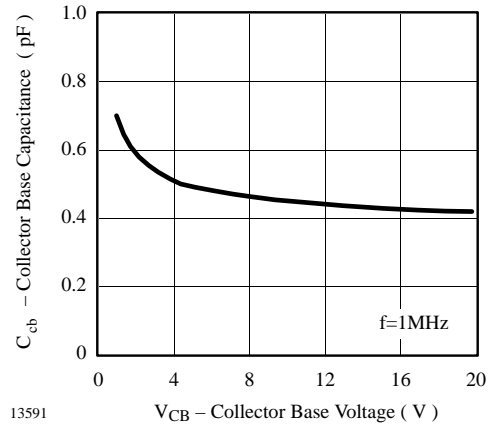

Figure 3. Collector Base Capacitance vs. Collector Base Voltage

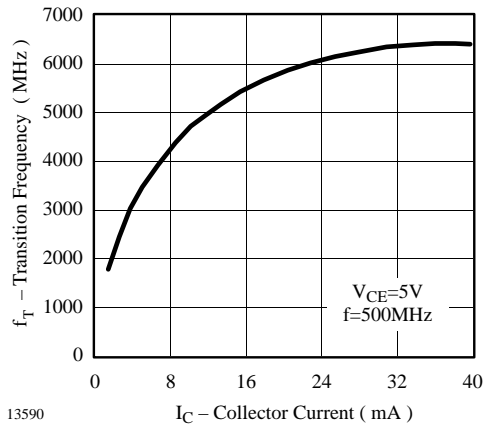

Figure 2. Transition Frequency vs. Collector Current

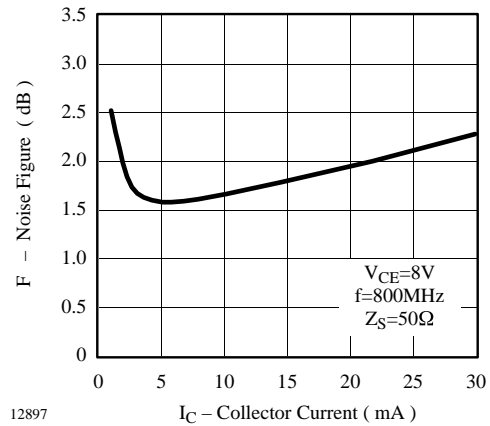

Figure 4. Noise Figure vs. Collector Current

$V_{CE} = 8\text{ V}$, $I_C = 25\text{ mA}$, $Z_0 = 50\ \Omega$

S_{11}

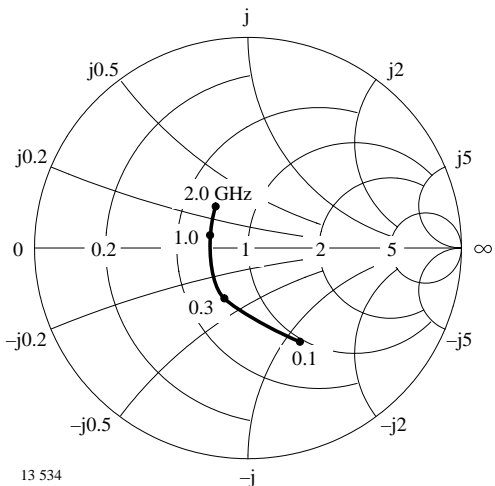

Figure 5. Input reflection coefficient

S_{12}

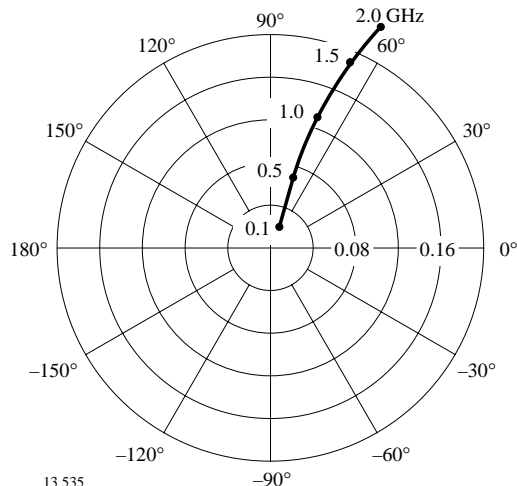

Figure 7. Reverse transmission coefficient

S_{21}

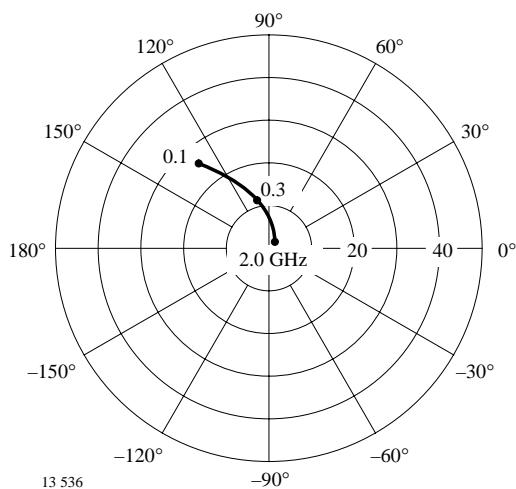

Figure 6. Forward transmission coefficient

S_{22}

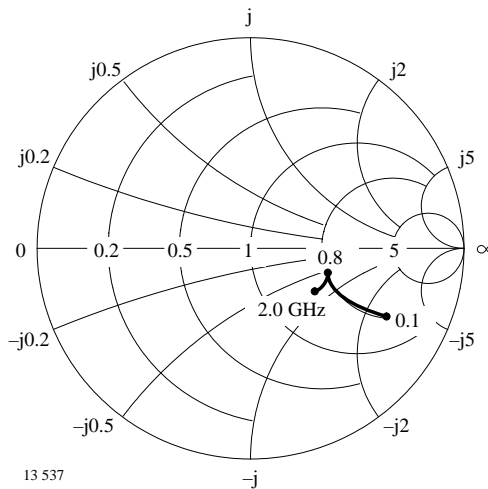

Figure 8. Output reflection coefficient



BFR93A/BFR93AR/BFR93AW

Vishay Semiconductors

Dimensions of BFR93A in mm

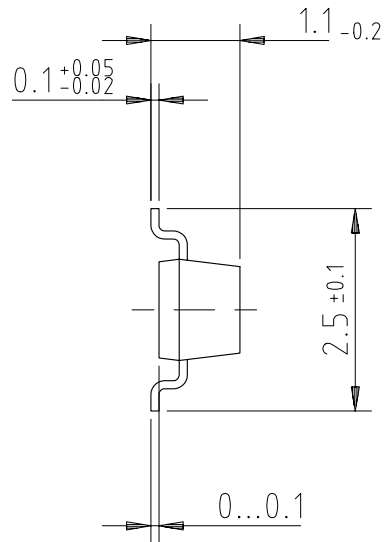
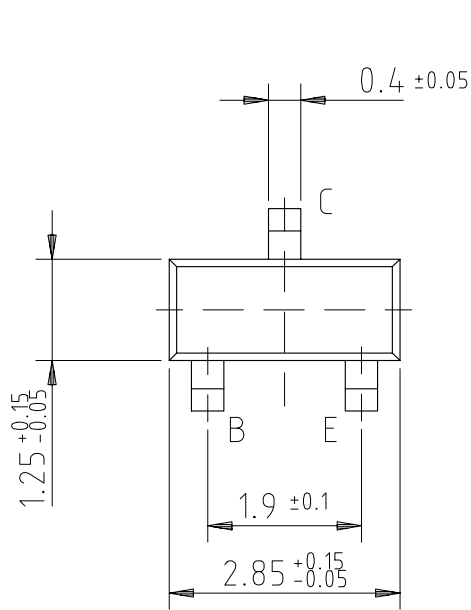

95 11346

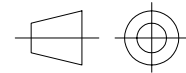

technical drawings
according to DIN
specifications

Dimensions of BFR93AR in mm

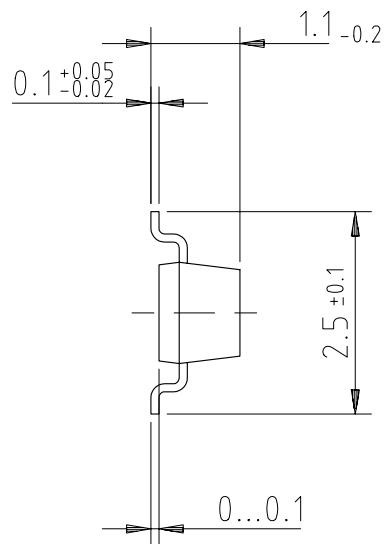
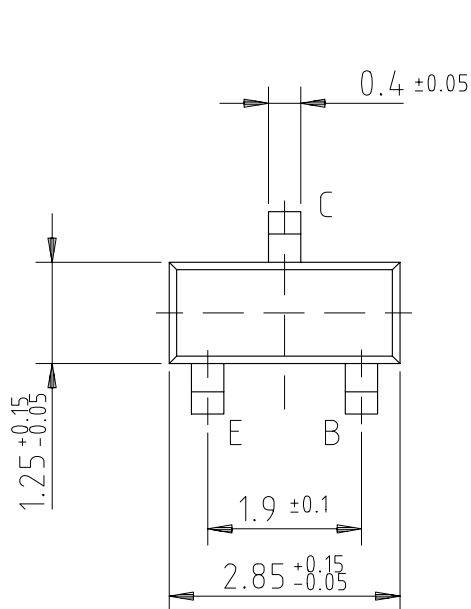

95 11347

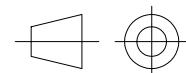

technical drawings
according to DIN
specifications

BFR93A/BFR93AR/BFR93AW

Vishay Semiconductors



Dimensions of BFR93AW in mm

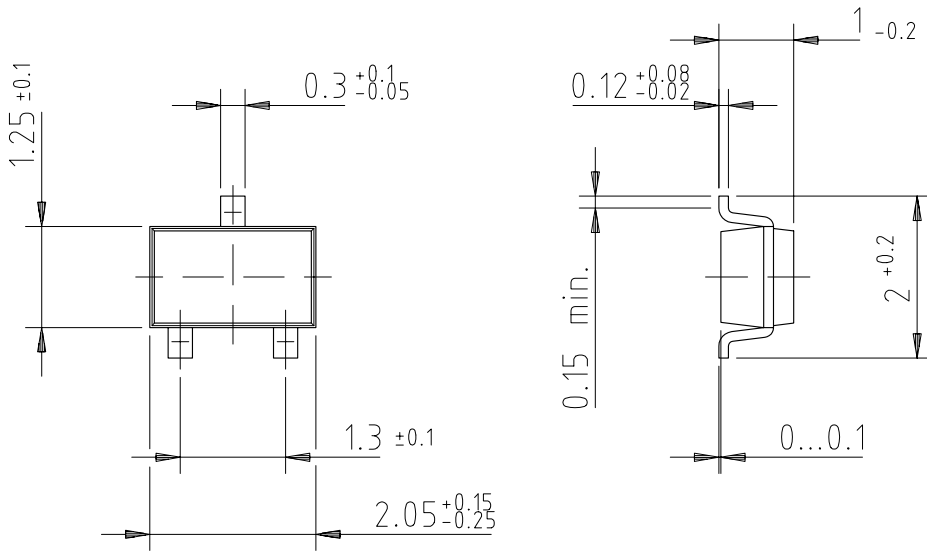

96 12236

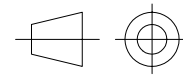

technical drawings
according to DIN
specifications



Ozone Depleting Substances Policy Statement

It is the policy of **Vishay Semiconductor GmbH** to

1. Meet all present and future national and international statutory requirements.
2. Regularly and continuously improve the performance of our products, processes, distribution and operating systems with respect to their impact on the health and safety of our employees and the public, as well as their impact on the environment.

It is particular concern to control or eliminate releases of those substances into the atmosphere which are known as ozone depleting substances (ODSs).

The Montreal Protocol (1987) and its London Amendments (1990) intend to severely restrict the use of ODSs and forbid their use within the next ten years. Various national and international initiatives are pressing for an earlier ban on these substances.

Vishay Semiconductor GmbH has been able to use its policy of continuous improvements to eliminate the use of ODSs listed in the following documents.

1. Annex A, B and list of transitional substances of the Montreal Protocol and the London Amendments respectively
2. Class I and II ozone depleting substances in the Clean Air Act Amendments of 1990 by the Environmental Protection Agency (EPA) in the USA
3. Council Decision 88/540/EEC and 91/690/EEC Annex A, B and C (transitional substances) respectively.

Vishay Semiconductor GmbH can certify that our semiconductors are not manufactured with ozone depleting substances and do not contain such substances.

We reserve the right to make changes to improve technical design and may do so without further notice.
Parameters can vary in different applications. All operating parameters must be validated for each customer application by the customer. Should the buyer use Vishay-Semiconductors products for any unintended or unauthorized application, the buyer shall indemnify Vishay-Semiconductors against all claims, costs, damages, and expenses, arising out of, directly or indirectly, any claim of personal damage, injury or death associated with such unintended or unauthorized use.

Vishay Semiconductor GmbH, P.O.B. 3535, D-74025 Heilbronn, Germany
Telephone: 49 (0) 7131 67 2831, Fax number: 49 (0) 7131 67 2423