

## Micropower 350-mA CMOS LDO Regulator With Error Flag/Power-On-Reset

### FEATURES

- Low 150-mV Dropout at 350-mA Load
- Guaranteed 350-mA Output Current
- 600-mA Peak Output Current Capability
- Uses Low ESR Ceramic Output Capacitor
- Fast Load and Line Transient Response
- Only 100- $\mu$ V(rms) Noise With Noise Bypass Capacitor
- 1- $\mu$ A Maximum Shutdown Current
- Built-in Short Circuit and Thermal Protection
- Out-Of-Regulation Error Flag (Power Good or POR)

- Fixed 1.5-V, 1.8-V, 2.0-V, 2.5-V, 2.8-V, 2.85-V, 2.9 V, 3.0-V, 3.3-V, 5.0-V, or Adjustable Output Voltage Options
- Other Output Voltages Available by Special Order

### APPLICATIONS

- Cellular Phones
- Laptop and Palm Computers
- PDA, Digital Still Cameras

### DESCRIPTION

The Si9181 is a 350-mA CMOS LDO (low dropout) voltage regulator. The device features ultra low ground current and dropout voltage to prolong battery life in portable electronics. The Si9181 offers line/load transient response and ripple rejection superior to that of bipolar or BiCMOS LDO regulators. The device is designed to maintain regulation while delivering 600-mA peak current. This is useful for systems that have high surge current upon turn-on. The Si9181 is designed to drive the lower cost ceramic, as well as tantalum, output capacitors. The device is guaranteed stable from maximum load current down to 0-mA load. In addition, an external noise bypass

capacitor connected to the device's  $C_{NOISE}$  pin will lower the LDO's output noise for low noise applications.

The Si9181 also includes an out-of-regulation error flag. When the output voltage is 5% below its nominal output voltage, the error flag output goes low. If a capacitor is connected to the device's delay pin, the error flag output pin will generate a delayed power-on-reset signal.

The Si9181 is available in both standard and lead (Pb)-free packages.

### TYPICAL APPLICATIONS CIRCUITS

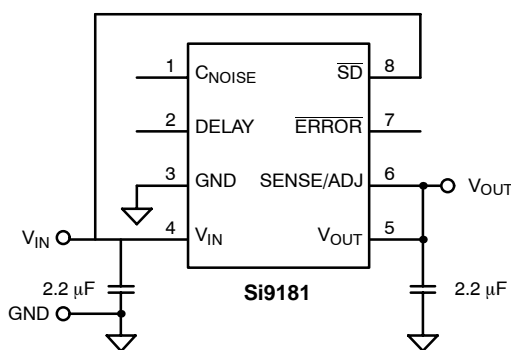

FIGURE 1. Fixed Output

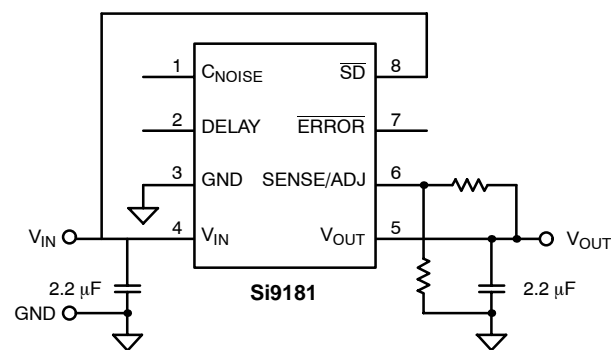

FIGURE 2. Adjustable Output

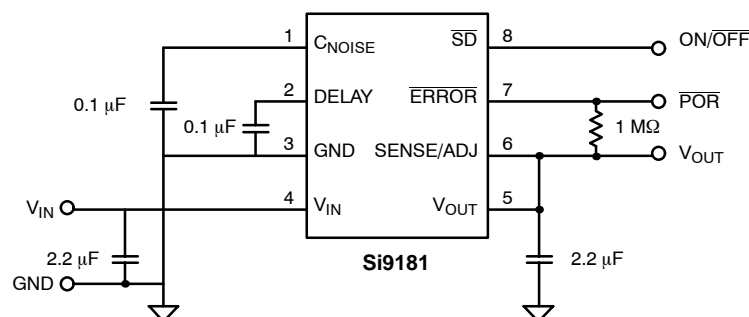

FIGURE 3. Low Noise, Full Features Application

### ABSOLUTE MAXIMUM RATINGS

Input Voltage, $V_{IN}$	6.5 V
SD Input Voltage, $V_{SD}$	-0.3 V to $V_{IN}$
Output Current, $I_{OUT}$	Short Circuit Protected
Output Voltage, $V_{OUT}$	-0.3 V to $V_{O(nom)} + 0.3$ V
Maximum Junction Temperature, $T_{J(max)}$	150°C
Storage Temperature, $T_{STG}$	-55°C to 150°C
ESD (Human Body Model)	2 kV

Power Dissipation (Package) <sup>a</sup>	
8-Pin TSSOP	833 mW
Thermal Impedance ( $\Theta_{JA}$ )	
8-Pin TSSOP <sup>b</sup>	120°C/W

#### Notes

- Device mounted with all leads soldered or welded to PC board.
- Derate 8.3 mW/°C above  $T_A = 25^\circ\text{C}$

Stresses beyond those listed under "Absolute Maximum Ratings" may cause permanent damage to the device. These are stress ratings only, and functional operation of the device at these or any other conditions beyond those indicated in the operational sections of the specifications is not implied. Exposure to absolute maximum rating conditions for extended periods may affect device reliability.

### RECOMMENDED OPERATING RANGE

Input Voltage, $V_{IN}$	2 V to 6 V
Output Voltage, $V_{OUT}$ (Adjustable Version)	1.5 V to 5 V
SD Input Voltage, $V_{SD}$	0 V to $V_{IN}$

Operating Ambient Temperature, $T_A$	-40°C to 85°C
Operating Junction Temperature, $T_J$	-40°C to 125°C

$C_{IN} = 2.2 \mu\text{F}$ ,  $C_{OUT} = 2.2 \mu\text{F}$  (ceramic, X5R or X7R type),  $C_{NOISE} = 0.1 \mu\text{F}$  (ceramic)

$C_{OUT Range} = 1 \mu\text{F}$  to  $10 \mu\text{F}$  ( $\pm 10\%$ , x5R or x7R type)

$C_{IN} \geq C_{OUT}$

SPECIFICATIONS								
Parameter	Symbol	Test Conditions Unless Otherwise Specified $V_{IN} = V_{OUT(nom)} + 1$ V, $I_{OUT} = 1$ mA $C_{IN} = 2.2 \mu\text{F}$ , $C_{OUT} = 2.2 \mu\text{F}$ , $V_{SD} = 1.5$ V	Temp <sup>a</sup>	Limits -40 to 85°C			Unit	
				Min <sup>b</sup>	Typ <sup>c</sup>	Max <sup>b</sup>		
Output Voltage Range	$V_{OUT}$	Adjustable Version	Full	1.5		5	V	
Output Voltage Accuracy (Fixed Versions)		$1 \text{ mA} \leq I_{OUT} \leq 350 \text{ mA}$	Room	-1.5		1.5	% $V_{O(nom)}$	
Feedback Voltage (ADJ Version)	$V_{ADJ}$		Room	1.191	1.215	1.239	V	
			Full	1.179		1.251		
Line Regulation (Except 5-V Version)	$\frac{\Delta V_{OUT} \times 100}{V_{IN} \times V_{OUT(nom)}}$	From $V_{IN} = V_{OUT(nom)} + 1$ V to $V_{OUT(nom)} + 2$ V	Full	-0.18		0.18	%V	
Line Regulation (5-V Version)		From $V_{IN} = 5.5$ V to 6 V	Full	-0.18		0.18		
Line Regulation (ADJ Version)		$V_{OUT} = 1.5$ V, From $V_{IN} = 2.5$ V to 3.5 V	Full	-0.18		0.18		
		$V_{OUT} = 5$ V, From $V_{IN} = 5.5$ V to 6 V	Full	-0.18		0.18		
Dropout Voltage <sup>d</sup> (@ $V_{OUT} \geq 2$ V)	$V_{IN} - V_{OUT}$	$I_{OUT} = 10$ mA	Room		5	20	mV	
		$I_{OUT} = 200$ mA	Room		85	180		
$I_{OUT} = 350$ mA		Room		150	400			
		Full			550			
Dropout Voltage <sup>d</sup> (@ $V_{OUT} < 2$ V, $V_{IN} \geq 2$ V)		$I_{OUT} = 200$ mA	Room		170	250		
		$I_{OUT} = 350$ mA	Room		290	425		
Ground Pin Current	$I_{GND}$	$I_{OUT} = 0$ mA	Room		150		$\mu\text{A}$	
			Room		1000			
		$I_{OUT} = 200$ mA	Full			1500		
			Room		1500			
$I_{OUT} = 350$ mA	Full				2800			



SPECIFICATIONS								
Parameter	Symbol	Test Conditions Unless Otherwise Specified $V_{IN} = V_{OUT(nom)} + 1\text{ V}$ , $I_{OUT} = 1\text{ mA}$ $C_{IN} = 2.2\ \mu\text{F}$ , $C_{OUT} = 2.2\ \mu\text{F}$ , $V_{SD} = 1.5\text{ V}$		Temp <sup>a</sup>	Limits -40 to 85°C			Unit
					Min <sup>b</sup>	Typ <sup>c</sup>	Max <sup>b</sup>	
Shutdown Supply Current	$I_{N(off)}$	$V_{SD} = 0\text{ V}$		Room		0.1	1	$\mu\text{A}$
ADJ Pin Current	$I_{ADJ}$	ADJ = 1.2 V		Room		5	100	nA
Peak Output Current	$I_{O(peak)}$	$V_{OUT} \geq 0.95 \times V_{OUT(nom)}$ , $t_{pw} = 2\text{ ms}$		Room	600			mA
Output Noise Voltage	$e_N$	BW = 50 Hz to 100 kHz $I_{OUT} = 150\text{ mA}$	w/o $C_{NOISE}$	Room		200		$\mu\text{V (rms)}$
			$C_{NOISE} = 0.1\ \mu\text{F}$	Room		100		
Ripple Rejection	$\Delta V_{OUT}/\Delta V_{IN}$	$I_{OUT} = 150\text{ mA}$	f = 1 kHz	Room		60		dB
			f = 10 kHz	Room		60		
			f = 100 kHz	Room		40		
Dynamic Line Regulation	$\Delta V_{O(line)}$	$V_{IN} : V_{OUT(nom)} + 1\text{ V}$ to $V_{OUT(nom)} + 2\text{ V}$ $t_R/t_F = 5\ \mu\text{s}$ , $I_{OUT} = 350\text{ mA}$		Room		10		mV
Dynamic Load Regulation	$\Delta V_{O(load)}$	$I_{OUT} : 1\text{ mA}$ to $150\text{ mA}$ , $t_R/t_F = 2\ \mu\text{s}$		Room		30		
$V_{OUT}$ Turn-On-Time	$t_{ON}$	$V_{IN} = 4.3\text{ V}$ $V_{OUT} = 3.3\text{ V}$	w/o $C_{NOISE}$ Cap	Room		5		$\mu\text{s}$
			$C_{NOISE} = 0.1\ \mu\text{F}$	Room		2		mS
<b>Thermal Shutdown</b>								
Thermal Shutdown Junction Temp	$t_{J(s/d)}$			Room		165		°C
Thermal Hysteresis	$t_{HYST}$			Room		20		
Short Circuit Current	$I_{SC}$	$V_{OUT} = 0\text{ V}$		Room		800		mA
<b>Shutdown Input</b>								
$\overline{SD}$ Input Voltage	$V_{IH}$	High = Regulator ON (Rising)		Full	1.5		$V_{IN}$	V
	$V_{IL}$	Low = Regulator OFF (Falling)		Full			0.4	
$\overline{SD}$ Input Current <sup>e</sup>	$I_{IH}$	$V_{SD} = 0\text{ V}$ , Regulator OFF		Room		0.01		$\mu\text{A}$
	$I_{IL}$	$V_{SD} = 6\text{ V}$ , Regulator ON		Room		1.0		
Shutdown Hysteresis	$V_{HYST}$			Full		100		mV
<b>Error Output</b>								
Output High Leakage	$I_{OFF}$	$\overline{ERROR} = V_{OUT(nom)}$		Full		0.01	2	$\mu\text{A}$
Output Low Voltage <sup>g</sup>	$V_{OL}$	$I_{SINK} = 2\text{ mA}$		Full			0.4	V
Power_Good Trip Threshold <sup>f, h</sup> (Rising)	$V_{TH}$			Full	$0.93 \times V_{OUT}$	$0.95 \times V_{OUT}$	$0.97 \times V_{OUT}$	
Hysteresis <sup>f</sup>	$V_{HYST}$			Room		$2\% \times V_{OUT}$		
Delay Pin Current Source	$I_{DELAY}$			Room	1.2	2.2	3.0	$\mu\text{A}$

Notes

- a. Room = 25°C, Full = -40 to 85°C.
- b. The algebraic convention whereby the most negative value is a minimum and the most positive a maximum.
- c. Typical values are for DESIGN AID ONLY, not guaranteed nor subject to production testing. Typical values for dropout voltage at  $V_{OUT} \geq 2\text{ V}$  are measured at  $V_{OUT} = 3.3\text{ V}$ , while typical values for dropout voltage at  $V_{OUT} < 2\text{ V}$  are measured at  $V_{OUT} = 1.8\text{ V}$ .
- d. Dropout voltage is defined as the input to output differential voltage at which the output voltage drops 2% below the output voltage measured with a 1-V differential, provided that  $V_{IN}$  does not drop below 2.0 V.
- e. The device's shutdown pin includes a typical 6-M $\Omega$  internal pull-down resistor connected to ground.
- f.  $V_{OUT}$  is defined as the output voltage of the DUT at 1 mA.
- g. The Error Output (Low) function is guaranteed from  $V_{OUT} = 2.0\text{ V}$  to  $V_{OUT} = 5.0\text{ V}$ .
- h. The Power\_Good trip threshold function is guaranteed from  $V_{OUT} = 1.5\text{ V}$  to  $V_{OUT} = 5.0\text{ V}$  and  $V_{IN} \geq 2.0\text{ V}$ .

## TIMING WAVEFORMS

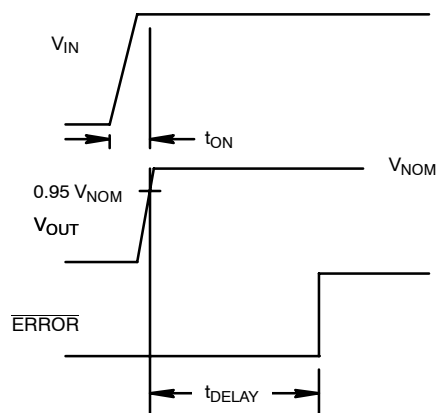
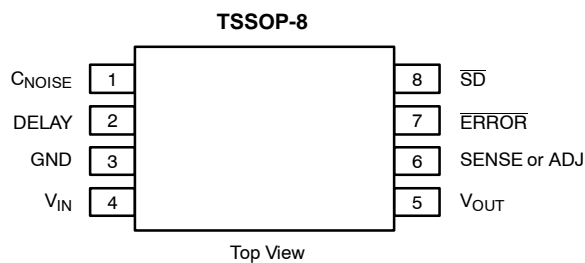

FIGURE 4. Timing Diagram for Power-Up

## PIN CONFIGURATION



## PIN DESCRIPTION

Pin Number	Name	Function
1	$C_{NOISE}$	Noise bypass pin. For low noise applications, a 0.01- $\mu$ F or larger ceramic capacitor should be connected from this pin to ground.
2	DELAY	Capacitor connected from this pin to ground will allow a delayed power-on-reset signal at the $ERROR$ (Pin 7) output. Refer to Figure 4.
3	GND	Ground pin. Local ground for $C_{NOISE}$ and $C_{OUT}$ .
4	$V_{IN}$	Input supply pin. Bypass this pin with a 2.2- $\mu$ F ceramic or tantalum capacitor to ground.
5	$V_{OUT}$	Output voltage. Connect $C_{OUT}$ between this pin and ground.
6	SENSE or ADJ	For fixed output voltage versions, this pin should be connected to $V_{OUT}$ (Pin 5). For adjustable output voltage version, this voltage feedback pin sets the output voltage via an external resistor divider.
7	$ERROR$	This open drain output is an error flag output which goes low when $V_{OUT}$ drops 5% below its nominal voltage. This pin also provides a power-on-reset signal if a capacitor is connected to the DELAY pin.
8	$\overline{SD}$	By applying less than 0.4 V to this pin, the device will be turned off. Connect this pin to $V_{IN}$ if unused.

ORDERING INFORMATION					
Part Number	Lead (Pb)-Free Part Number	Marking	Voltage	Temperature Range	Package
Si9181DQ-15-T1	Si9181DQ-15-T1—E3	115	1.5 V	-40 to 85°C	TSSOP-8
Si9181DQ-18-T1	Si9181DQ-18-T1—E3	118	1.8 V		
Si9181DQ-20-T1	Si9181DQ-20-T1—E3	120	2.0 V		
Si9181DQ-25-T1	Si9181DQ-25-T1—E3	125	2.5 V		
Si9181DQ-28-T1	Si9181DQ-28-T1—E3	128	2.8 V		
Si9181DQ-285-T1	Si9181DQ-285-T1—E3	285	2.85 V		
Si9181DQ-29-T1	Si9181DQ-29-T1—E3	129	2.9 V		
Si9181DQ-30-T1	Si9181DQ-30-T1—E3	130	3.0 V		
Si9181DQ-33-T1	Si9181DQ-33-T1—E3	133	3.3 V		
Si9181DQ-50-T1	Si9181DQ-50-T1—E3	150	5.0 V		
Si9181DQ-AD-T1	Si9181DQ-AD-T1—E3	1AD	Adjustable		

\* Additional voltage options are available.

Eval Kit	Temperature Range	Board Type
Si9181DB	-40 to 85°C	Surface Mount

**TYPICAL CHARACTERISTICS (INTERNALLY REGULATED, 25°C UNLESS NOTED)**

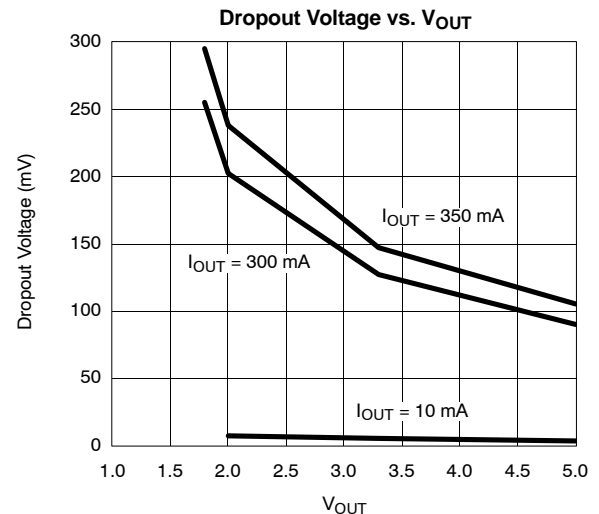
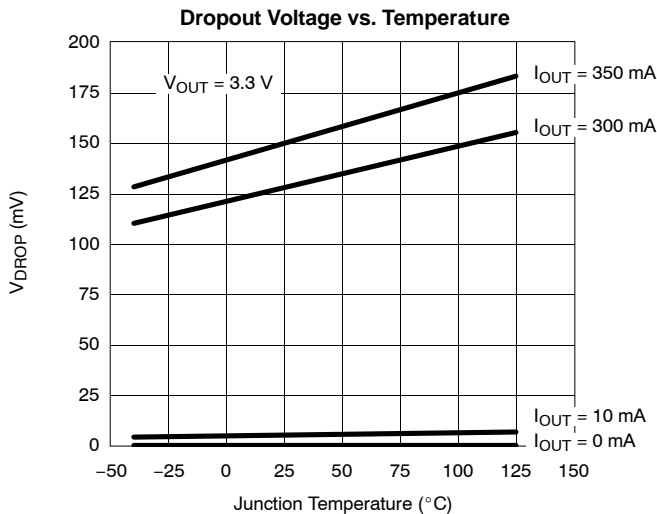
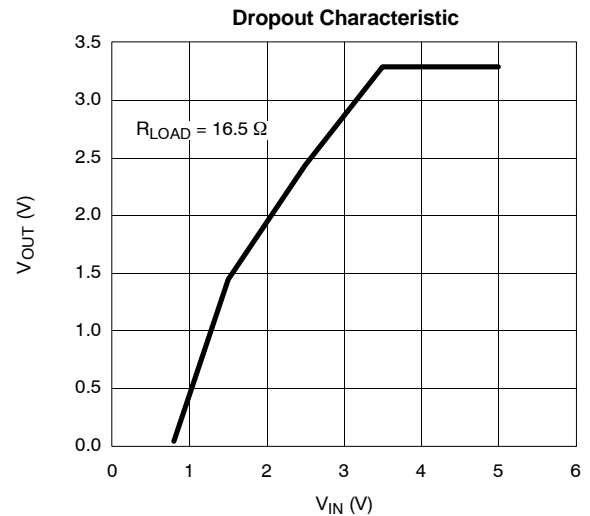
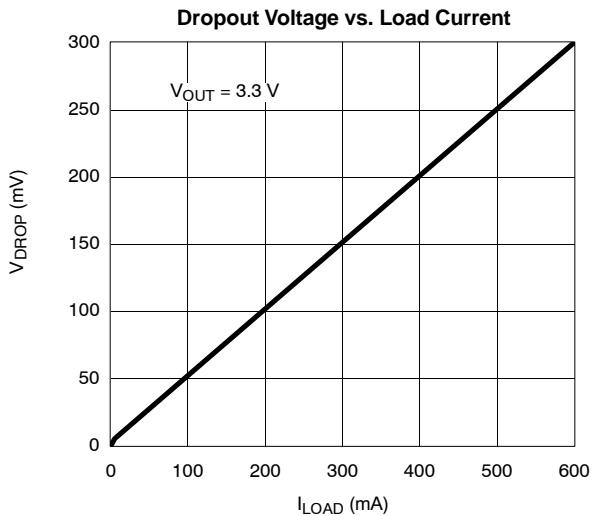



**TYPICAL CHARACTERISTICS (INTERNALLY REGULATED, 25°C UNLESS NOTED)**

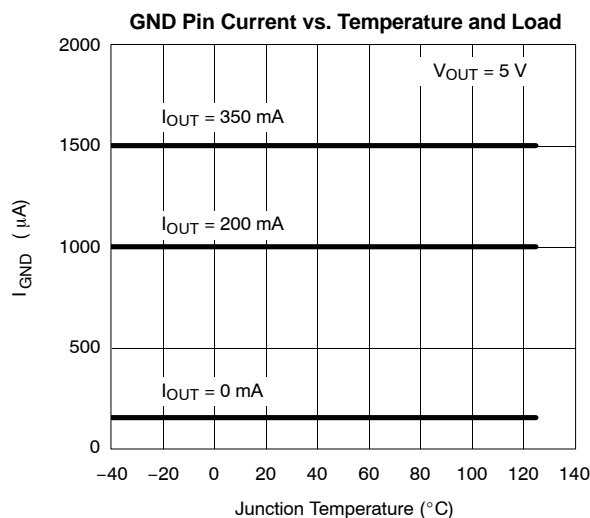
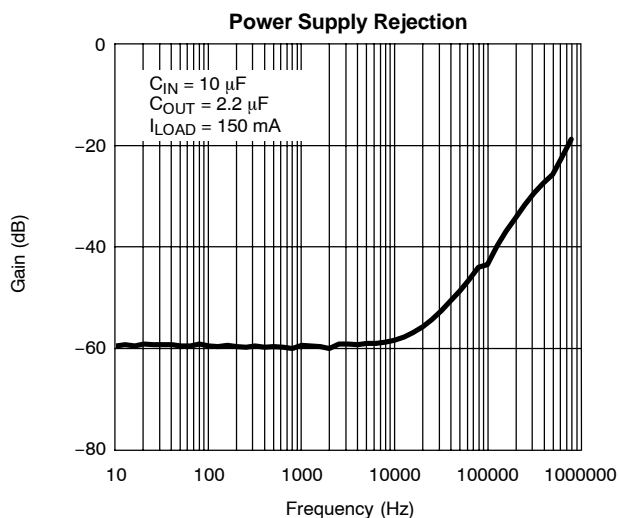
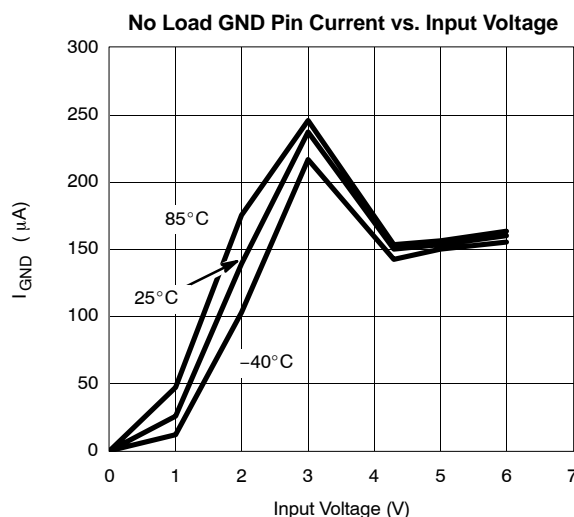
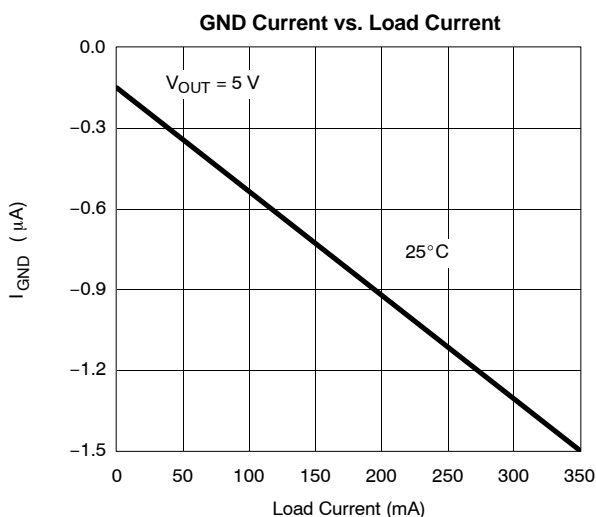
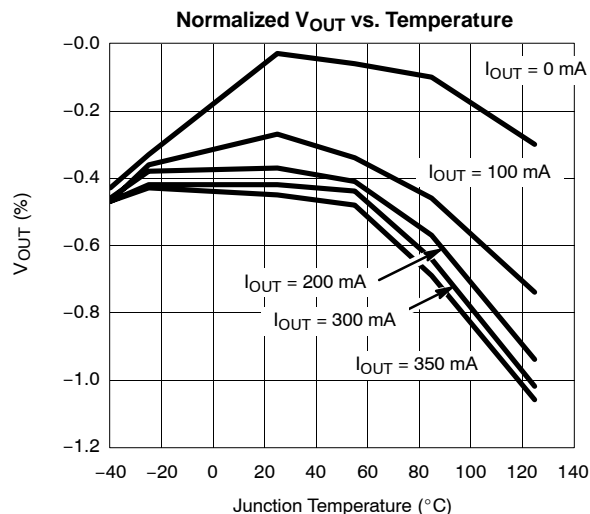
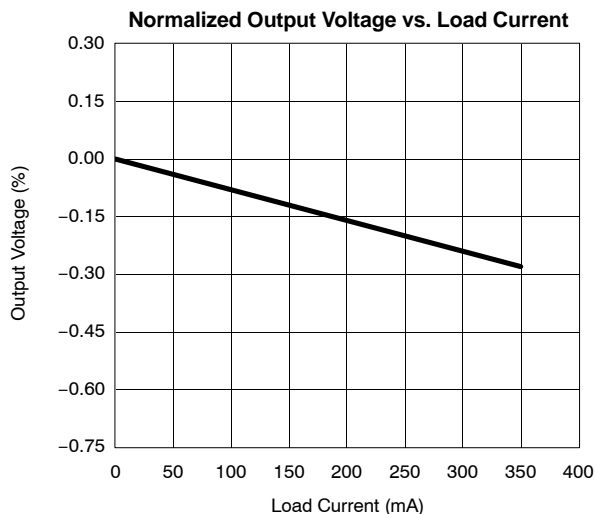

**TYPICAL WAVEFORMS**

**Load Transient Response-1**

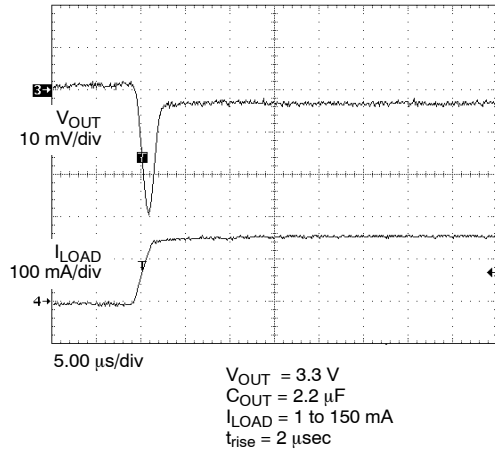

**Load Transient Response-2**

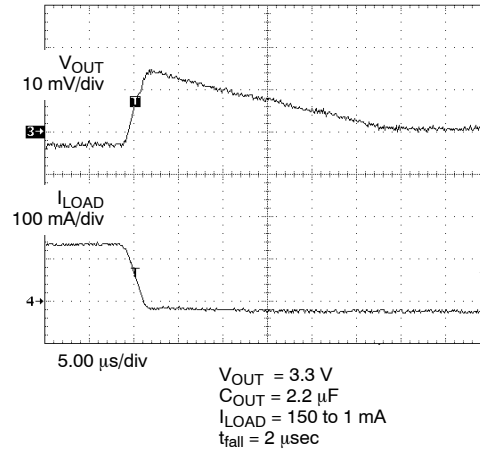

**Load Transient Response-3**

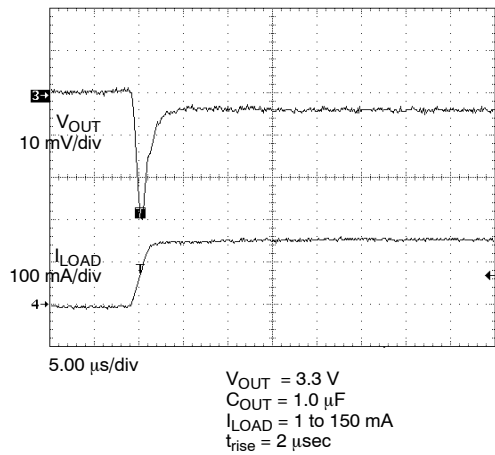

**Load Transient Response-4**

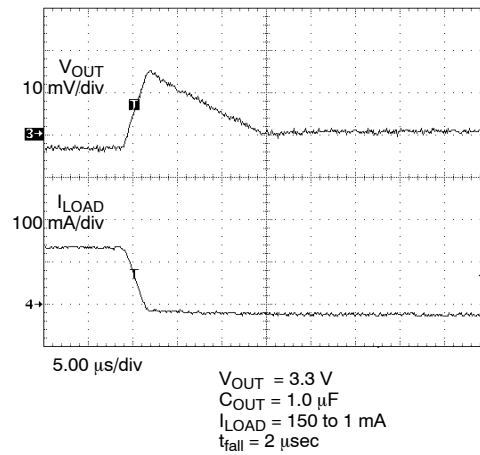

**Line Transient Response-1**

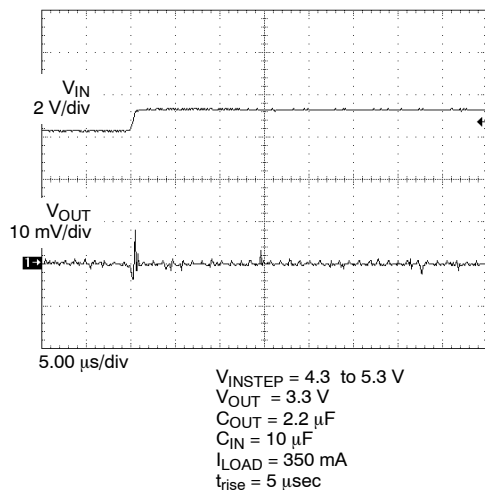

**Line Transient Response-2**

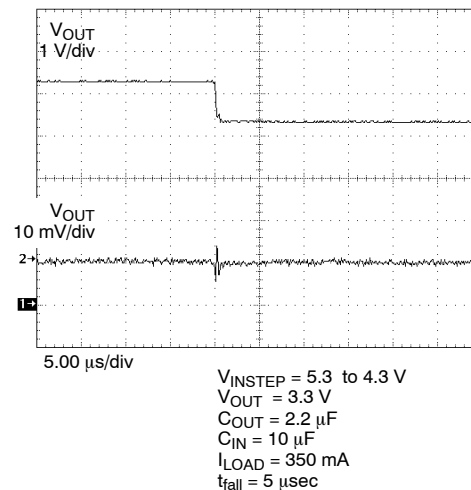

**TYPICAL WAVEFORMS**

**Turn-On Sequence**

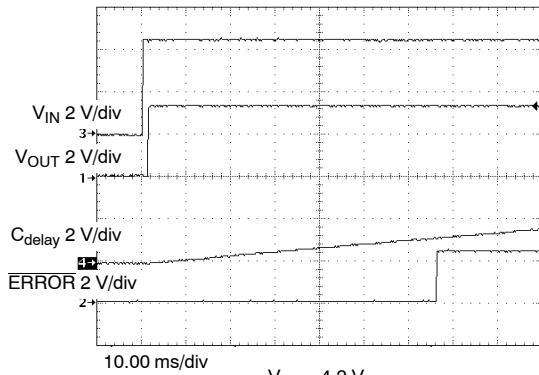

$V_{IN} = 4.2\text{ V}$   
 $V_{OUT} = 3.3\text{ V}$   
 $C_{delay} = 0.1\text{ }\mu\text{F}$   
 $C_{NOISE} = 0.1\text{ }\mu\text{F}$   
 $I_{LOAD} = 350\text{ mA}$

**Turn-Off Sequence**

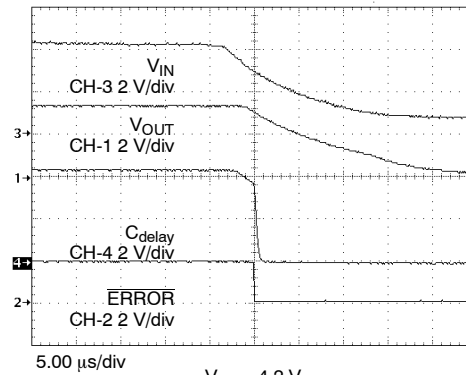

$V_{IN} = 4.2\text{ V}$   
 $V_{OUT} = 3.3\text{ V}$   
 $C_{delay} = 0.1\text{ }\mu\text{F}$   
 $C_{NOISE} = 0.1\text{ }\mu\text{F}$   
 $I_{LOAD} = 350\text{ mA}$

**Output Noise**

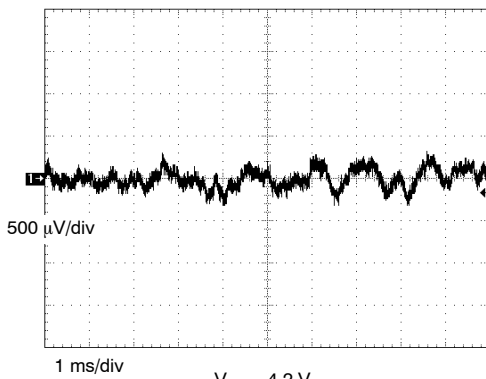

$V_{IN} = 4.2\text{ V}$   
 $V_{OUT} = 3.3\text{ V}$   
 $I_{OUT} = 150\text{ mA}$   
 $C_{NOISE} = 0.1\text{ }\mu\text{F}$   
 $BW = 10\text{ Hz to }1\text{ MHz}$

**Noise Spectrum**

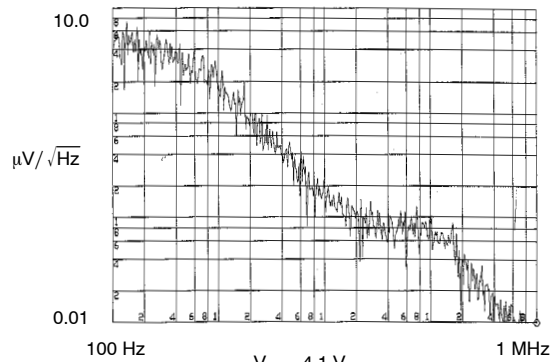

$V_{IN} = 4.1\text{ V}$   
 $V_{OUT} = 3.3\text{ V}/10\text{ mA}$   
 $C_{NOISE} = 0.1\text{ }\mu\text{F}$



**BLOCK DIAGRAMS**

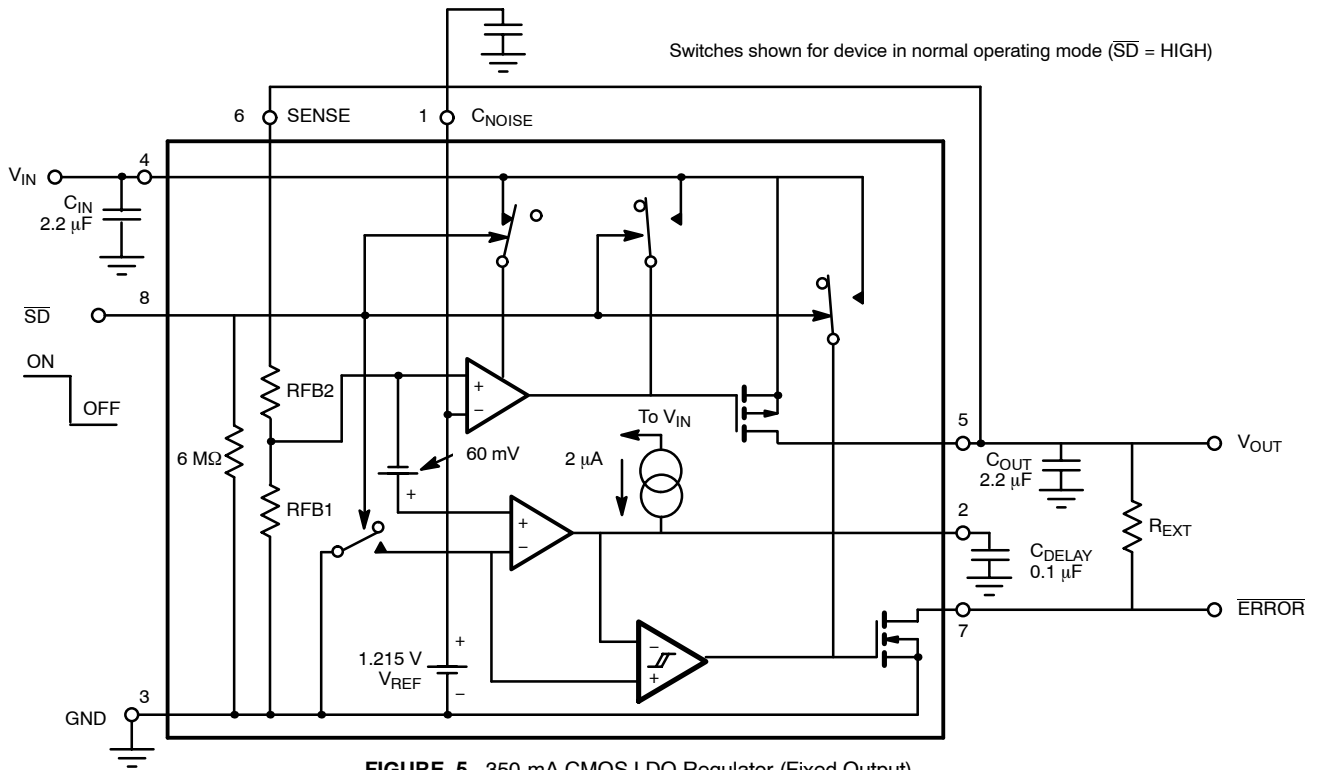

**FIGURE 5.** 350-mA CMOS LDO Regulator (Fixed Output)

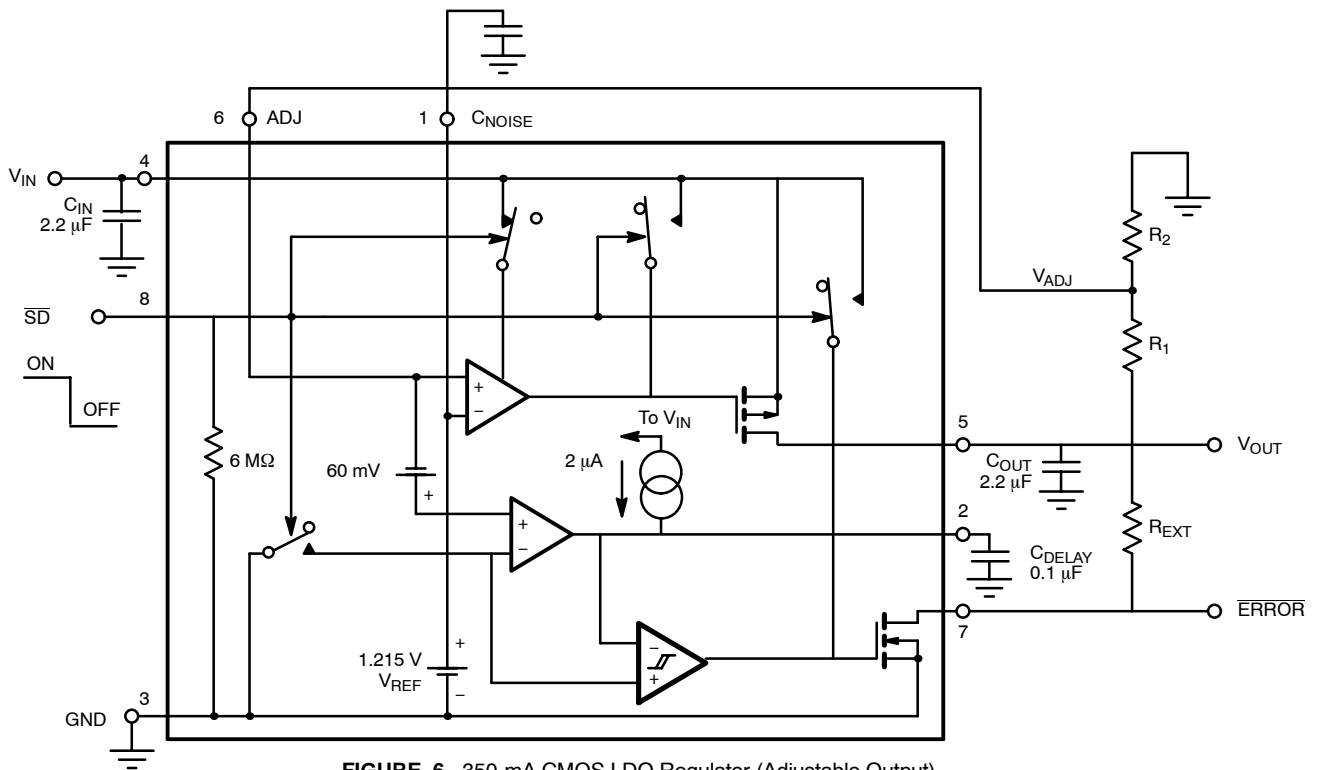

**FIGURE 6.** 350-mA CMOS LDO Regulator (Adjustable Output)

## DETAILED DESCRIPTION

The Si9181 is a low drop out, low quiescent current, and very linear regulator family with very fast transient response. It is primarily designed for battery powered applications where battery run time is at a premium. The low quiescent current allows extended standby time while low drop out voltage enables the system to fully utilize battery power before recharge. The Si9181 is a very fast regulator with bandwidth exceeding 50 kHz while maintaining low quiescent current at light load conditions. With this bandwidth, the Si9181 is the fastest LDO available today. The Si9181 is stable with any output capacitor type from 1  $\mu\text{F}$  to 10.0  $\mu\text{F}$ . However, X5R or X7R ceramic capacitors are recommended for best output noise and transient performance.

### $V_{\text{IN}}$

$V_{\text{IN}}$  is the input supply pin. The bypass capacitor for this pin is not critical as long as the input supply has low enough source impedance. For practical circuits, a 1.0- $\mu\text{F}$  or larger ceramic capacitor is recommended. When the source impedance is not low enough and/or the source is several inches from the Si9181, then a larger input bypass capacitor is needed. It is required that the equivalent impedance (source impedance, wire, and trace impedance in parallel with input bypass capacitor impedance) must be smaller than the input impedance of the Si9181 for stable operation. When the source impedance, wire, and trace impedance are unknown, it is recommended that an input bypass capacitor be used of a value that is equal to or greater than the output capacitor.

### $V_{\text{OUT}}$

$V_{\text{OUT}}$  is the output voltage of the regulator. Connect a bypass capacitor from  $V_{\text{OUT}}$  to ground. The output capacitor can be any value from 1.0  $\mu\text{F}$  to 10.0  $\mu\text{F}$ . A ceramic capacitor with X5R or X7R dielectric type is recommended for best output noise, line transient, and load transient performance.

### GND

Ground is the common ground connection for  $V_{\text{IN}}$  and  $V_{\text{OUT}}$ . It is also the local ground connection for  $C_{\text{NOISE}}$ , DELAY, SENSE or ADJ, and  $\overline{\text{SD}}$ .

### SENSE or ADJ

SENSE is used to sense the output voltage. Connect SENSE to  $V_{\text{OUT}}$  for the fixed voltage version. For the adjustable output version, use a resistor divider R1 and R2, connect R1 from  $V_{\text{OUT}}$  to ADJ and R2 from ADJ to ground. R2 should be in the 25-k $\Omega$  to 150-k $\Omega$  range for low power consumption, while maintaining adequate noise immunity.

The formula below calculates the value of R1, given the desired output voltage and the R2 value,

$$R1 = \frac{(V_{\text{OUT}} - V_{\text{ADJ}})R2}{V_{\text{ADJ}}} \quad (1)$$

$V_{\text{ADJ}}$  is nominally 1.215 V.

### SHUTDOWN ( $\overline{\text{SD}}$ )

$\overline{\text{SD}}$  controls the turning on and off of the Si9181.  $V_{\text{OUT}}$  is guaranteed to be on when the  $\overline{\text{SD}}$  pin voltage equals or is greater than 1.5 V.  $V_{\text{OUT}}$  is guaranteed to be off when the  $\overline{\text{SD}}$  pin voltage equals or is less than 0.4 V. During shutdown mode, the Si9181 will draw less than 2- $\mu\text{A}$  current from the source. To automatically turn on  $V_{\text{OUT}}$  whenever the input is applied, tie the  $\overline{\text{SD}}$  pin to  $V_{\text{IN}}$ .

### ERROR

$\overline{\text{ERROR}}$  is an open drain output that goes low when  $V_{\text{OUT}}$  is less than 5% of its normal value. As with any open drain output, an external pull up resistor is needed. When a capacitor is connected from DELAY to GROUND, the error signal transition from low to high is delayed (see Delay section). This delayed error signal can be used as the power-on reset signal for the application system. (Refer to Figure 4.)

The  $\overline{\text{ERROR}}$  pin is disconnected if not used.

### DELAY

A capacitor from DELAY to GROUND sets the time delay for  $\overline{\text{ERROR}}$  going from low to high state. The time delay can be calculated using the following formula:

$$T_{\text{delay}} = \frac{(V_{\text{ADJ}})C_{\text{delay}}}{I_{\text{delay}}} \quad (2)$$

The DELAY pin should be an open circuit if not used.

### $C_{\text{NOISE}}$

For low noise application, connect a high frequency ceramic capacitor from  $C_{\text{NOISE}}$  to ground. A 0.01- $\mu\text{F}$  or a 0.1- $\mu\text{F}$  X5R or X7R is recommended.