

PNP SILICON PLANAR MEDIUM POWER TRANSISTOR

2N6732

ISSUE 1 – MARCH 94

FEATURES

- * 80 Volt V_{CEO}
- * Gain of 100 at $I_C = 350$ mA
- * $P_{tot} = 1$ Watt

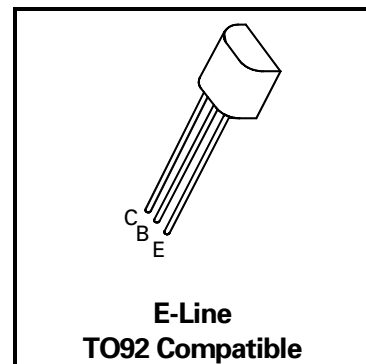

ABSOLUTE MAXIMUM RATINGS.

PARAMETER	SYMBOL	VALUE	UNIT
Collector-Base Voltage	V_{CBO}	-100	V
Collector-Emitter Voltage	V_{CEO}	-80	V
Emitter-Base Voltage	V_{EBO}	-5	V
Peak Pulse Current	I_{CM}	-2	A
Continuous Collector Current	I_C	-1	A
Power Dissipation at $T_{amb} = 25^\circ\text{C}$	P_{tot}	1	W
Operating and Storage Temperature Range	$T_j; T_{stg}$	-55 to +200	$^\circ\text{C}$

ELECTRICAL CHARACTERISTICS (at $T_{amb} = 25^\circ\text{C}$ unless otherwise stated).

PARAMETER	SYMBOL	MIN.	TYP.	MAX.	UNIT	CONDITIONS.
Collector-Base Breakdown Voltage	$V_{(BR)CBO}$	-100			V	$I_C = -100\mu\text{A}, I_E = 0$
Collector-Emitter Breakdown Voltage	$V_{(BR)CEO}$	-80			V	$I_C = -10\text{mA}, I_B = 0^*$
Emitter-Base Breakdown Voltage	$V_{(BR)EBO}$	-5			V	$I_E = -1\text{mA}, I_C = 0$
Collector Cut-Off Current	I_{CBO}			-0.1	μA	$V_{CB} = -80\text{V}, I_E = 0$
Emitter Cut-Off Current	I_{EBO}			-10	μA	$V_{EB} = -5\text{V}, I_C = 0$
Collector-Emitter Saturation Voltage	$V_{CE(sat)}$			-0.35	V	$I_C = -350\text{mA}, I_B = -35\text{mA}^*$
Base-Emitter Turn-On Voltage	$V_{BE(on)}$			-1.0	V	$I_C = -350\text{mA}, V_{CE} = -2\text{V}^*$
Static Forward Current Transfer Ratio	h_{FE}	100	100	300		$I_C = -10\text{mA}, V_{CE} = -2\text{V}^*$ $I_C = -350\text{mA}, V_{CE} = -2\text{V}^*$
Transition Frequency	f_T	50		500	MHz	$I_C = -200\text{mA}, V_{CE} = -5\text{V}$ $f = 20\text{MHz}$
Collector-Base Capacitance	C_{CB}			20	pF	$V_{CB} = -10\text{V}, f = 1\text{MHz}$

*Measured under pulsed conditions. Pulse width=300 μs . Duty cycle $\leq 2\%$