

#### Key Features

- SMPTE 292M and SMPTE 259M-C compliant descrambling and NRZI → NRZ decoding (with bypass)
- DVB-ASI sync word detection and 8b/10b decoding
- auto-configuration for HD-SDI, SD-SDI and DVB-ASI
- serial loop-through cable driver output selectable as reclocked or non-reclocked
- dual serial digital input buffers with 2 x 1 mux
- integrated serial digital signal termination
- integrated reclocker
- automatic or manual rate selection / indication (HD/SD)
- descrambler bypass option
- user selectable additional processing features including:
  - CRC, TRS, ANC data checksum, line number and EDH CRC error detection and correction
  - programmable ANC data detection
  - illegal code remapping
- internal flywheel for noise immune H, V, F extraction
- FIFO load Pulse
- 20-bit / 10-bit CMOS parallel output data bus
- 148.5MHz / 74.25MHz / 27MHz / 13.5MHz parallel digital output
- automatic standards detection and indication
- 1.8V core power supply and 3.3V charge pump power supply
- 3.3V digital I/O supply
- JTAG test interface
- Available in a Pb-free package
- small footprint (11mm x 11mm)

#### Applications

- SMPTE 292M Serial Digital Interfaces
- SMPTE 259M-C Serial Digital Interfaces
- DVB-ASI Serial Digital Interfaces

#### Description

The GS1559 is a reclocking deserializer with a serial loop-through cable driver. When used in conjunction with the GS1574 Automatic Cable Equalizer and the GO1525 Voltage Controlled Oscillator, a receive solution can be realized for HD-SDI, SD-SDI and DVB-ASI applications.

In addition to reclocking and deserializing the input data stream, the GS1559 performs NRZI-to-NRZ decoding, descrambling as per SMPTE 292M/259M-C, and word alignment when operating in SMPTE mode. When operating in DVB-ASI mode, the device will word align the data to K28.5 sync characters and 8b/10b decode the received stream.

Two serial digital input buffers are provided with a 2x1 multiplexer to allow the device to select from one of two serial digital input signals.

The integrated reclocker features a very wide Input Jitter Tolerance of  $\pm 0.3$  UI (total 0.6 UI), a rapid asynchronous lock time, and full compliance with DVB-ASI data streams.

An integrated cable driver is provided for serial input loop-through applications and can be selected to output either buffered or reclocked data. This cable driver also features an output mute on loss of signal, high impedance mode, adjustable signal swing, and automatic dual slew-rate selection depending on HD/SD operational requirements.

The GS1559 also includes a range of data processing functions such as error detection and correction, automatic standards detection, and EDH support. The device can also detect and extract SMPTE 352M payload identifier packets and independently identify the received video standard. This information is read from internal registers via the host interface port.

Line-based CRC errors, line number errors, TRS errors, EDH CRC errors and ancillary data checksum errors can all be detected. A single 'DATA\_ERROR' pin is provided which is a logical 'OR'ing of all detectable errors. Individual error status is stored in internal 'ERROR\_STATUS' registers.

Finally, the device can correct detected errors and insert new TRS ID words, line-based CRC words, ancillary data checksum words, EDH CRC words, and line numbers. Illegal code re-mapping is also available. All processing functions may be individually enabled or disabled via host interface control.

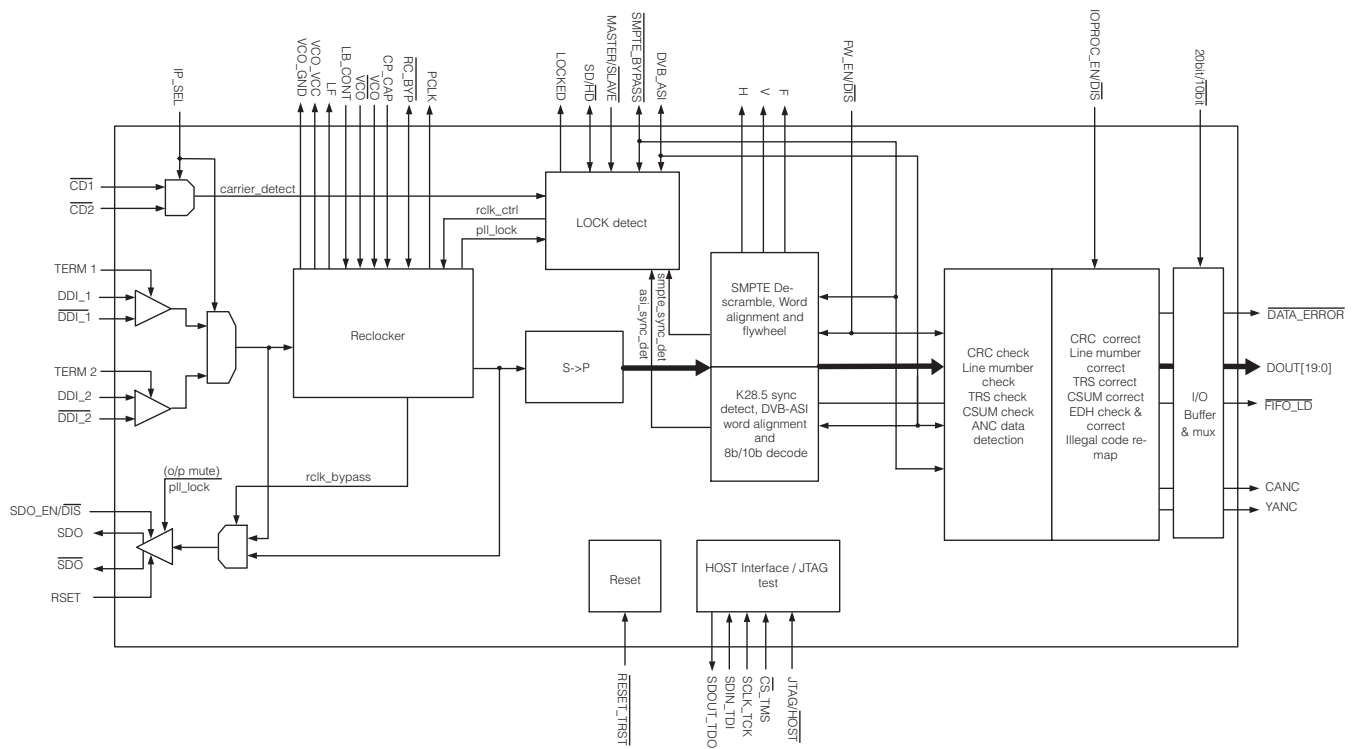

GS1559 Functional Block Diagram

# Contents

Key Features.....	1
Applications.....	1
Description .....	1
1. Pin Out .....	5
1.1 Pin Assignment .....	5
1.2 Pin Descriptions .....	6
2. Electrical Characteristics.....	16
2.1 Absolute Maximum Ratings .....	16
2.2 DC Electrical Characteristics .....	16
2.3 AC Electrical Characteristics.....	18
2.4 Solder Reflow Profiles.....	20
3. Input/Output Circuits .....	21
3.1 Host Interface Map.....	23
3.1.1 Host Interface Map (R/W Configurable Registers) .....	24
3.1.2 Host Interface Map (Read Only Registers).....	25
4. Detailed Description .....	26
4.1 Functional Overview .....	26
4.2 Serial Digital Input.....	26
4.2.1 Input Signal Selection .....	27
4.2.2 Carrier Detect Input .....	27
4.2.3 Single Input Configuration .....	27
4.3 Serial Digital Reclocker .....	27
4.3.1 External VCO.....	28
4.3.2 Loop Bandwidth .....	28
4.4 Serial Digital Loop-Through Output .....	28
4.4.1 Output Swing .....	29
4.4.2 Reclocker Bypass Control .....	29
4.4.3 Serial Digital Output Mute.....	30
4.5 Serial-To-Parallel Conversion .....	30
4.6 Modes Of Operation.....	31
4.6.1 Lock Detect.....	31
4.6.2 Master Mode.....	32
4.6.3 Slave Mode.....	32
4.7 SMPTE Functionality .....	34
4.7.1 SMPTE Descrambling and Word Alignment.....	34
4.7.2 Internal Flywheel.....	34
4.7.3 Switch Line Lock Handling.....	35
4.7.4 HVF Timing Signal Generation .....	39
4.8 DVB-ASI Functionality .....	41
4.8.1 DVB-ASI 8b/10b Decoding and Word Alignment.....	41

4.8.2 Status Signal Outputs .....	41
4.9 Data Through Mode .....	42
4.10 Additional Processing Functions .....	42
4.10.1 FIFO Load Pulse .....	42
4.10.2 Ancillary Data Detection and Indication .....	43
4.10.3 SMPTE 352M Payload Identifier .....	47
4.10.4 Automatic Video Standard and Data Format Detection .....	47
4.10.5 Error Detection and Indication .....	51
4.10.6 Error Correction and Insertion .....	56
4.10.7 EDH Flag Detection .....	59
4.11 Parallel Data Outputs .....	60
4.11.1 Parallel Data Bus Buffers .....	61
4.11.2 Parallel Output in SMPTE Mode .....	62
4.11.3 Parallel Output in DVB-ASI Mode .....	62
4.11.4 Parallel Output in Data-Through Mode .....	62
4.11.5 Parallel Output Clock (PCLK) .....	62
4.12 GSPI Host Interface .....	64
4.12.1 Command Word Description .....	64
4.12.2 Data Read and Write Timing .....	65
4.12.3 Configuration and Status Registers .....	66
4.13 JTAG .....	66
4.14 Device Power Up .....	68
4.15 Device Reset .....	68
5. Application Reference Design .....	69
5.1 Typical Application Circuit (Part A) .....	69
5.2 Typical Application Circuit (Part B) .....	70
6. References & Relevant Standards .....	71
7. Package & Ordering Information .....	72
7.1 Package Dimensions .....	72
7.2 Packaging Data .....	73
7.3 Ordering Information .....	73
8. Revision History .....	74

# 1. Pin Out

## 1.1 Pin Assignment

	1	2	3	4	5	6	7	8	9	10
A	LF	VCO_VCC	VCO_GND	$\overline{\text{VCO}}$	VCO	NC	PCLK	IO_VDD	DOUT18	DOUT19
B	CP_CAP	CP_VDD	CP_GND	LB_CONT	NC	NC	FW_EN/ /DIS	IO_GND	DOUT16	DOUT17
C	BUFF_VDD	PD_VDD	PD/BUFF_GND	NC	NC	MASTER/ SLAVE	$\overline{\text{RC\_BYP}}$	YANC	DOUT14	DOUT15
D	DDI1	NC	NC	IP_SEL	DVB_ASI	LOCKED	NC	CANC	DOUT12	DOUT13
E	$\overline{\text{DDI1}}$	TERM1	NC	$\overline{\text{SD/HD}}$	CORE_GND	CORE_VDD	NC	IO_VDD	DOUT10	DOUT11
F	$\overline{\text{CD1}}$	NC	NC	20bit/ 10bit	CORE_GND	CORE_VDD	NC	IO_GND	DOUT8	DOUT9
G	DDI2	NC	NC	IOPROC_EN/DIS	$\overline{\text{SMPTE\_BYPASS}}$	$\overline{\text{RESET\_TRST}}$	NC	$\overline{\text{FIFO\_LD}}$	DOUT6	DOUT7
H	$\overline{\text{DDI2}}$	TERM2	NC	$\overline{\text{CS\_TMS}}$	SCLK_TCK	SDOUT_TDO	$\overline{\text{DATA\_ERROR}}$	H	DOUT4	DOUT5
J	$\overline{\text{CD2}}$	NC	NC	NC	SDO_EN/DIS	SDIN_TDI	V	IO_GND	DOUT2	DOUT3
K	RSET	CD_VDD	SDO	$\overline{\text{SDO}}$	CD_GND	JTAG/HOST	F	IO_VDD	DOUT0	DOUT1

## 1.2 Pin Descriptions

**Table 1-1: Pin Descriptions**

Pin Number	Name	Timing	Type	Description
A1	LF	Analog	Output	Control voltage to external voltage controlled oscillator. Nominally +1.25V DC.
A2	VCO_VCC	–	Output Power	Power supply for the external voltage controlled oscillator. Connect to pin 7 of the GO1525. This pin is an output. Should be isolated from all other power supplies.
A3	VCO_GND	–	Output Power	Ground reference for the external voltage controlled oscillator. Connect to pins 2, 4, 6, and 8 of the GO1525. This pin is an output. Should be isolated from all other grounds.
A4, A5	$\overline{\text{VCO}}$ , VCO	Analog	Input	Differential inputs for the external VCO reference signal. For single ended devices such as the GO1525, $\overline{\text{VCO}}$ should be AC coupled to VCO_GND. VCO is nominally 1.485GHz.
A6, B5, B6, C4, C5, D2, D3, D7, E3, E7, F2, F3, F7, G2, G3, G7, H3, J2, J3, J4,	NC	–	–	No Connect.
A7	PCLK	–	Output	PARALLEL DATA BUS CLOCK Signal levels are LVCMOS/LVTTL compatible.
				HD 20-bit mode                      PCLK = 74.25MHz or 74.25/1.001MHz
				HD 10-bit mode                      PCLK = 148.5MHz or 148.5/1.001MHz
				SD 20-bit mode                      PCLK = 13.5MHz
				SD 10-bit mode                      PCLK = 27MHz
A8, E8, K8	IO_VDD	–	Power	Power supply connection for digital I/O buffers. Connect to +3.3V DC digital.

Table 1-1: Pin Descriptions (Continued)

Pin Number	Name	Timing	Type	Description
A10, A9, B10, B9, C10, C9, D10, D9, E10, E9	DOUT[19:10]	Synchronous with PCLK	Output	<p>PARALLEL DATA BUS Signal levels are LVCMOS/LVTTL compatible. DOUT19 is the MSB and DOUT10 is the LSB.</p> <hr/> <p>HD 20-bit mode SD/HD = LOW 20bit/10bit = HIGH</p> <p>Luma data output in SMPTE mode SMPTE_BYPASS = HIGH DVB_ASI = LOW</p> <p>Data output in Data-Through mode SMPTE_BYPASS = LOW DVB_ASI = LOW</p> <hr/> <p>HD 10-bit mode SD/HD = LOW 20bit/10bit = LOW</p> <p>Multiplexed Luma and Chroma data output in SMPTE mode SMPTE_BYPASS = HIGH DVB_ASI = LOW</p> <p>Data output in Data-Through mode SMPTE_BYPASS = LOW DVB_ASI = LOW</p> <hr/> <p>SD 20-bit mode SD/HD = HIGH 20bit/10bit = HIGH</p> <p>Luma data output in SMPTE mode SMPTE_BYPASS = HIGH DVB_ASI = LOW</p> <p>Data output in Data-Through mode SMPTE_BYPASS = LOW DVB_ASI = LOW</p> <p>DVB-ASI data in DVB-ASI mode SMPTE_BYPASS = LOW DVB_ASI = HIGH</p> <hr/> <p>SD 10-bit mode SD/HD = HIGH 20bit/10bit = LOW</p> <p>Multiplexed Luma and Chroma data output in SMPTE mode SMPTE_BYPASS = HIGH DVB_ASI = LOW</p> <p>Data input in data through mode SMPTE_BYPASS = LOW DVB_ASI = LOW</p> <p>DVB-ASI data in DVB-ASI mode SMPTE_BYPASS = LOW DVB_ASI = HIGH</p>
B1	CP_CAP	Analog	Input	PLL lock time constant capacitor connection. Normally connected to VCO_GND through 2.2nF.
B2	CP_VDD	–	Power	Power supply connection for the charge pump. Connect to +3.3V DC analog.
B3	CP_GND	–	Power	Ground connection for the charge pump. Connect to analog GND.
B4	LB_CONT	Analog	Input	Control voltage to set the loop bandwidth of the integrated reclocker. Normally connected to VCO_GND through 40kΩ.

Table 1-1: Pin Descriptions (Continued)

Pin Number	Name	Timing	Type	Description
B7	FW_EN/DIS	Non Synchronous	Input	<p>CONTROL SIGNAL INPUT Signal levels are LVCMOS/LVTTL compatible.</p> <p>Used to enable or disable the noise immune flywheel of the device.</p> <p>When set HIGH, the internal flywheel is enabled. This flywheel is used in the extraction and generation of TRS timing signals, in automatic video standards detection, and in manual switch line lock handling.</p> <p>When set LOW, the internal flywheel is disabled and TRS correction and insertion is unavailable.</p>
B8, F8, J8	IO_GND	–	Power	Ground connection for digital I/O buffers. Connect to digital GND.
C1	BUFF_VDD	–	Power	Power supply connection for the serial digital input buffers. Connect to +1.8V DC analog.
C2	PD_VDD	–	Power	Power supply connection for the phase detector. Connect to +1.8V DC analog.
C3	PDBUFF_GND	–	Power	Ground connection for the phase detector and serial digital input buffers. Connect to analog GND.
C6	MASTER/SLAVE	Non Synchronous	Input	<p>CONTROL SIGNAL INPUT Signal levels are LVCMOS/LVTTL compatible.</p> <p>Used to determine the input / output selection for the DVB_ASI, SD/HD, RC_BYP and SMPTE_BYPASS pins.</p> <p>When set HIGH, the GS1559 is set to operate in master mode where DVB_ASI, SD/HD, RC_BYP and SMPTE_BYPASS become status signal output pins set by the device. In this mode, the GS1559 will automatically detect, relock, deserialize and process SD SMPTE, HD SMPTE, or DVB-ASI input data.</p> <p>When set LOW, the GS1559 is set to operate in slave mode where DVB_ASI, SD/HD, RC_BYP and SMPTE_BYPASS become control signal input pins. In this mode, the application layer must set these external device pins for the correct reception of either SMPTE or DVB-ASI data. Slave mode also supports the relocking and deserializing of data not conforming to SMPTE or DVB-ASI streams.</p>
C7	RC_BYP	Non Synchronous	Input /Output	<p>CONTROL SIGNAL INPUT / STATUS SIGNAL OUTPUT Signal levels are LVCMOS/LVTTL compatible.</p> <p>This pin will be an input set by the application layer in slave mode, and will be an output set by the device in master mode.</p> <p>Master Mode (MASTER/SLAVE = HIGH) The RC_BYP signal will be HIGH only when the device has successfully locked to a SMPTE or DVB-ASI compliant input data stream. In this case, the serial digital loop-through output will be a relocked version of the input.</p> <p>The RC_BYP signal will be LOW whenever the input does not conform to a SMPTE or DVB-ASI compliant data stream. In this case, the serial digital loop-through output will be a buffered version of the input.</p> <p>Slave Mode (MASTER/SLAVE = LOW) When set HIGH, the serial digital output will be a relocked version of the input signal regardless of whether the device is in SMPTE, DVB-ASI or Data-Through mode.</p> <p>When set LOW, the serial digital output will be a buffered version of the input signal in all modes.</p>



Table 1-1: Pin Descriptions (Continued)

Pin Number	Name	Timing	Type	Description
C8	YANC	Synchronous with PCLK	Output	<p>STATUS SIGNAL OUTPUT Signal levels are LVCMOS/LVTTL compatible.</p> <p>Used to indicate the presence of ancillary data in the video stream.</p> <p>HD Mode (<math>\overline{SD/HD}</math> = LOW) The YANC signal will be HIGH when the device has detected VANC or HANC data in the luma video stream and LOW otherwise.</p> <p>SD Mode (<math>\overline{SD/HD}</math> = LOW) For 20-bit demultiplexed data (<math>\overline{20bit/10bit}</math> = HIGH), the YANC signal will be HIGH when VANC or HANC data is detected in the luma video stream and LOW otherwise.</p> <p>For 10-bit multiplexed data (<math>\overline{20bit/10bit}</math> = LOW), the YANC signal will be HIGH when VANC or HANC data is detected anywhere in the data stream and LOW otherwise.</p>
D1, E1	DDI1, $\overline{DDI1}$	Analog	Input	Differential input pair for serial digital input 1.
D4	IP_SEL	Non Synchronous	Input	<p>CONTROL SIGNAL INPUT Signal levels are LVCMOS/LVTTL compatible.</p> <p>Used to select <math>\overline{DDI1}</math> / <math>\overline{DDI1}</math> or <math>\overline{DDI2}</math> / <math>\overline{DDI2}</math> as the serial digital input signal, and <math>\overline{CD1}</math> or <math>\overline{CD2}</math> as the carrier detect input signal.</p> <p>When set HIGH, <math>\overline{DDI1}</math> / <math>\overline{DDI1}</math> is selected as the serial digital input and <math>\overline{CD1}</math> is selected as the carrier detect input signal.</p> <p>When set LOW, <math>\overline{DDI2}</math> / <math>\overline{DDI2}</math> serial digital input and <math>\overline{CD2}</math> carrier detect input signal is selected.</p>
D5	DVB_ASI	Non Synchronous	Input / Output	<p>CONTROL SIGNAL INPUT / STATUS SIGNAL OUTPUT Signal levels are LVCMOS/LVTTL compatible.</p> <p>This pin will be an input set by the application layer in slave mode, and will be an output set by the device in master mode.</p> <p>Master Mode (<math>\overline{MASTER/SLAVE}</math> = HIGH) The DVB_ASI signal will be HIGH only when the device has locked to a DVB-ASI compliant data stream. It will be LOW otherwise.</p> <p>Slave Mode (<math>\overline{MASTER/SLAVE}</math> = LOW) When set HIGH in conjunction with <math>\overline{SD/HD}</math> = HIGH and <math>\overline{SMPTE\_BYPASS}</math> = LOW, the device will be configured to operate in DVB-ASI mode.</p> <p>When set LOW, the device will not support the decoding or word alignment of received DVB-ASI data.</p>
D6	LOCKED	Synchronous with PCLK	Output	<p>STATUS SIGNAL OUTPUT Signal levels are LVCMOS / LVTTL compatible.</p> <p>The LOCKED signal will be HIGH whenever the device has correctly received and locked to SMPTE compliant data in SMPTE mode or DVB-ASI compliant data in DVB-ASI mode.</p> <p>It will be LOW otherwise.</p>

Table 1-1: Pin Descriptions (Continued)

Pin Number	Name	Timing	Type	Description
D8	CANC	Synchronous with PCLK	Output	<p>STATUS SIGNAL OUTPUT Signal levels are LVCMOS/LVTTL compatible.</p> <p>Used to indicate the presence of ancillary data in the video stream.</p> <p>HD Mode (<math>\overline{SD/HD}</math> = LOW) The CANC signal will be HIGH when the device has detected VANC or HANC data in the chroma video stream and LOW otherwise.</p> <p>SD Mode (<math>\overline{SD/HD}</math> = LOW) For 20-bit demultiplexed data (<math>\overline{20bit/10bit}</math> = HIGH), the CANC signal will be HIGH when VANC or HANC data is detected in the chroma video stream and LOW otherwise.</p> <p>For 10-bit multiplexed data (<math>\overline{20bit/10bit}</math> = LOW), the CANC signal will be HIGH when VANC or HANC data is detected anywhere in the data stream and LOW otherwise.</p>
E2	TERM1	Analog	Input	Termination for serial digital input 1. AC couple to EQ_GND.
E4	$\overline{SD/HD}$	Non Synchronous	Input / Output	<p>CONTROL SIGNAL INPUT / STATUS SIGNAL OUTPUT Signal levels are LVCMOS/LVTTL compatible.</p> <p>This pin will be an input set by the application layer in slave mode, and will be an output set by the device in master mode.</p> <p>Master Mode (<math>\overline{MASTER/SLAVE}</math> = HIGH) The <math>\overline{SD/HD}</math> signal will be LOW whenever the received serial digital signal is 1.485Gb/s or 1.485/1.001Gb/s.</p> <p>The <math>\overline{SD/HD}</math> signal will be HIGH whenever the received serial digital signal is 270Mb/s.</p> <p>Slave Mode (<math>\overline{MASTER/SLAVE}</math> = LOW) When set LOW, the device will be configured for the reception of 1.485Gb/s or 1.485/1.001Gb/s signals only and will not lock to any other serial digital signal.</p> <p>When set HIGH, the device will be configured for the reception of 270Mb/s signals only and will not lock to any other serial digital signal.</p> <p>NOTE: When in slave mode, reset the device after the <math>\overline{SD/HD}</math> input has been initially configured, and after each subsequent <math>\overline{SD/HD}</math> data rate change.</p> <p>NOTE: This pin has an internal pull-up resistor of 100K.</p>
E5, F5	CORE_GND	–	Power	Ground connection for the digital core logic. Connect to digital GND.
E6, F6	CORE_VDD	–	Power	Power supply connection for the digital core logic. Connect to +1.8V DC digital.
F1	$\overline{CD1}$	Non Synchronous	Input	<p>STATUS SIGNAL INPUT Signal levels are LVCMOS/LVTTL compatible.</p> <p>Used to indicate the presence of a serial digital input signal. Normally generated by a Gennum automatic cable equalizer.</p> <p>When LOW, the serial digital input signal received at the DDI1 and <math>\overline{DDI1}</math> pins is considered valid.</p> <p>When HIGH, the associated serial digital input signal is considered to be invalid. In this case, the LOCKED signal is set LOW and all parallel outputs are muted.</p>

Table 1-1: Pin Descriptions (Continued)

Pin Number	Name	Timing	Type	Description
F4	20bit/10bit	Non Synchronous	Input	<p>CONTROL SIGNAL INPUT Signal levels are LVCMOS/LVTTL compatible.</p> <p>Used to select the output data bus width in SMPTE or Data-Through modes. This signal is ignored in DVB-ASI mode.</p> <p>When set HIGH, the parallel output will be 20-bit demultiplexed data. When set LOW, the parallel outputs will be 10-bit multiplexed data.</p>
F10, F9, G10, G9, H10, H9, J10, J9, K10, K9	DOUT[9:0]	Synchronous with PCLK	Output	<p>PARALLEL DATA BUS Signal levels are LVCMOS/LVTTL compatible. DOUT9 is the MSB and DOUT0 is the LSB.</p> <hr/> <p>HD 20-bit mode SD/HD = LOW 20bit/10bit = HIGH</p> <p>Chroma data output in SMPTE mode SMPTE_BYPASS = HIGH DVB_ASI = LOW</p> <p>Data output in Data-Through mode SMPTE_BYPASS = LOW DVB_ASI = LOW</p> <hr/> <p>HD 10-bit mode SD/HD = LOW 20bit/10bit = LOW</p> <p>Forced LOW in all modes.</p> <hr/> <p>SD 20-bit mode SD/HD = HIGH 20bit/10bit = HIGH</p> <p>Chroma data output in SMPTE mode SMPTE_BYPASS = HIGH DVB_ASI = LOW</p> <p>Data output in Data-Through mode SMPTE_BYPASS = LOW DVB_ASI = LOW</p> <p>Forced LOW in DVB-ASI mode SMPTE_BYPASS = LOW DVB_ASI = HIGH</p> <hr/> <p>SD 10-bit mode SD/HD = HIGH 20bit/10bit = LOW</p> <p>Forced LOW in all modes.</p>
G1, H1	DDI2, $\overline{\text{DDI2}}$	Analog	Input	Differential input pair for serial digital input 2.

Table 1-1: Pin Descriptions (Continued)

Pin Number	Name	Timing	Type	Description
G4	IOPROC_EN/DIS	Non Synchronous	Input	<p>CONTROL SIGNAL INPUT Signal levels are LVCMOS/LVTTL compatible. Used to enable or disable I/O processing features. When set HIGH, the following I/O processing features of the device are enabled:</p> <ul style="list-style-type: none"> <li>• EDH CRC Error Correction (SD-only)</li> <li>• ANC Data Checksum Correction</li> <li>• Line-based CRC Error Correction (HD-only)</li> <li>• Line Number Error Correction (HD-only)</li> <li>• TRS Error Correction</li> <li>• Illegal Code Remapping</li> </ul> <p>To enable a subset of these features, keep IOPROC_EN/DIS HIGH and disable the individual feature(s) in the IOPROC_DISABLE register accessible via the host interface. When set LOW, the I/O processing features of the device are disabled, regardless of whether the features are enabled in the IOPROC_DISABLE register.</p>
G5	SMPTE_BYPASS	Non Synchronous	Input / Output	<p>CONTROL SIGNAL INPUT / STATUS SIGNAL OUTPUT Signal levels are LVCMOS/LVTTL compatible. This pin will be an input set by the application layer in slave mode, and will be an output set by the device in master mode. Master Mode (MASTER/SLAVE = HIGH) The SMPTE_BYPASS signal will be HIGH only when the device has locked to a SMPTE compliant data stream. It will be LOW otherwise. Slave Mode (MASTER/SLAVE = LOW) When set HIGH in conjunction with DVB_ASI = LOW, the device will be configured to operate in SMPTE mode. All I/O processing features may be enabled in this mode. When set LOW, the device will not support the descrambling, decoding or word alignment of received SMPTE data. No I/O processing features will be available.</p>
G6	RESET_TRST	Non Synchronous	Input	<p>CONTROL SIGNAL INPUT Signal levels are LVCMOS/LVTTL compatible. Used to reset the internal operating conditions to default settings and to reset the JTAG test sequence. Host Mode (JTAG/HOST = LOW) When asserted LOW, all functional blocks will be set to default conditions and all input and output signals become high impedance, including the serial digital outputs SDO and SDO. Must be set HIGH for normal device operation. NOTE: When in slave mode, reset the device after the SD/HD input has been initially configured, and after each subsequent SD/HD data rate change. JTAG Test Mode (JTAG/HOST = HIGH) When asserted LOW, all functional blocks will be set to default and the JTAG test sequence will be held in reset. When set HIGH, normal operation of the JTAG test sequence resumes.</p>

Table 1-1: Pin Descriptions (Continued)

Pin Number	Name	Timing	Type	Description
G8	$\overline{\text{FIFO\_LD}}$	Synchronous with PCLK	Output	CONTROL SIGNAL OUTPUT Signal levels are LVCMOS/LVTTL compatible. Used as a control signal for external FIFO(s). Normally HIGH but will go LOW for one PCLK period at SAV.
H2	TERM2	Analog	Input	Termination for serial digital input 2. AC couple to PDBUFF_GND.
H4	$\overline{\text{CS\_TMS}}$	Synchronous with SCLK_TCK	Input	CONTROL SIGNAL INPUT Signal levels are LVCMOS/LVTTL compatible. Chip Select / Test Mode Select Host Mode (JTAG/ $\overline{\text{HOST}}$ = LOW) $\overline{\text{CS\_TMS}}$ operates as the host interface chip select, $\overline{\text{CS}}$ , and is active LOW. JTAG Test Mode (JTAG/ $\overline{\text{HOST}}$ = HIGH) $\overline{\text{CS\_TMS}}$ operates as the JTAG test mode select, TMS, and is active HIGH. NOTE: If the host interface is not being used, tie this pin HIGH.
H5	SCLK_TCK	Non Synchronous	Input	CONTROL SIGNAL INPUT Signal levels are LVCMOS/LVTTL compatible. Serial Data Clock / Test Clock. Host Mode (JTAG/ $\overline{\text{HOST}}$ = LOW) SCLK_TCK operates as the host interface burst clock, SCLK. Command and data read/write words are clocked into the device synchronously with this clock. JTAG Test Mode (JTAG/ $\overline{\text{HOST}}$ = HIGH) SCLK_TCK operates as the JTAG test clock, TCK. NOTE: If the host interface is not being used, tie this pin HIGH.
H6	SDOUT_TDO	Synchronous with SCLK_TCK	Output	CONTROL SIGNAL OUTPUT Signal levels are LVCMOS/LVTTL compatible. Serial Data Output / Test Data Output Host Mode (JTAG/ $\overline{\text{HOST}}$ = LOW) SDOUT_TDO operates as the host interface serial output, SDOUT, used to read status and configuration information from the internal registers of the device. JTAG Test Mode (JTAG/ $\overline{\text{HOST}}$ = HIGH) SDOUT_TDO operates as the JTAG test data output, TDO.
H7	$\overline{\text{DATA\_ERROR}}$	Synchronous with PCLK	Output	STATUS SIGNAL OUTPUT Signal levels are LVCMOS/LVTTL compatible. The $\overline{\text{DATA\_ERROR}}$ signal will be LOW when an error within the received data stream has been detected by the device. This pin is a logical 'OR'ing of all detectable errors listed in the internal ERROR_STATUS register. Once an error is detected, $\overline{\text{DATA\_ERROR}}$ will remain LOW until the start of the next video frame / field, or until the ERROR_STATUS register is read via the host interface. The $\overline{\text{DATA\_ERROR}}$ signal will be HIGH when the received data stream has been detected without error. NOTE: It is possible to program which error conditions are monitored by the device by setting appropriate bits of the ERROR_MASK register HIGH. All error conditions are detected by default.

Table 1-1: Pin Descriptions (Continued)

Pin Number	Name	Timing	Type	Description
H8	H	Synchronous with PCLK	Output	<p>STATUS SIGNAL OUTPUT Signal levels are LVCMOS/LVTTL compatible.</p> <p>Used to indicate the portion of the video line containing active video data. H signal timing is configurable via the H_CONFIG bit of the IOPROC_DISABLE register accessible via the host interface.</p> <p>Active Line Blanking (H_CONFIG = 0<sub>h</sub>) The H signal will be HIGH for the entire horizontal blanking period, including the EAV and SAV TRS words, and LOW otherwise. This is the default setting.</p> <p>TRS Based Blanking (H_CONFIG = 1<sub>h</sub>) The H signal will be HIGH for the entire horizontal blanking period as indicated by the H bit in the received TRS ID words, and LOW otherwise.</p>
J1	$\overline{\text{CD2}}$	Non Synchronous	Input	<p>STATUS SIGNAL INPUT Signal levels are LVCMOS/LVTTL compatible.</p> <p>Used to indicate the presence of a serial digital input signal. Normally generated by a Gennum automatic cable equalizer.</p> <p>When LOW, the serial digital input signal received at the DDI2 and <math>\overline{\text{DDI2}}</math> pins is considered valid.</p> <p>When HIGH, the associated serial digital input signal is considered to be invalid. In this case, the LOCKED signal is set LOW and all parallel outputs are muted.</p>
J5	$\overline{\text{SDO\_EN/DIS}}$	Non Synchronous	Input	<p>CONTROL SIGNAL INPUT Signal levels are LVCMOS/LVTTL compatible.</p> <p>Used to enable or disable the serial digital output loop-through stage.</p> <p>When set LOW, the serial digital output signals SDO and <math>\overline{\text{SDO}}</math> are disabled and become high impedance.</p> <p>When set HIGH, the serial digital output signals SDO and <math>\overline{\text{SDO}}</math> are enabled.</p>
J6	SDIN_TDI	Synchronous with SCLK_TCK	Input	<p>CONTROL SIGNAL INPUT Signal levels are LVCMOS/LVTTL compatible.</p> <p>Serial Data In / Test Data Input Host Mode (JTAG/<math>\overline{\text{HOST}}</math> = LOW) SDIN_TDI operates as the host interface serial input, SDIN, used to write address and configuration information to the internal registers of the device.</p> <p>JTAG Test Mode (JTAG/<math>\overline{\text{HOST}}</math> = HIGH) SDIN_TDI operates as the JTAG test data input, TDI.</p> <p>NOTE: If the host interface is not being used, tie this pin HIGH.</p>
J7	V	Synchronous with PCLK	Output	<p>STATUS SIGNAL OUTPUT Signal levels are LVCMOS/LVTTL compatible.</p> <p>Used to indicate the portion of the video field / frame that is used for vertical blanking.</p> <p>The V signal will be HIGH for the entire vertical blanking period as indicated by the V bit in the received TRS signals.</p> <p>The V signal will be LOW for all lines outside of the vertical blanking interval.</p>
K1	RSET	Analog	Input	Used to set the serial digital loop-through output signal amplitude. Connect to CD_VDD through 281 $\Omega$ +/- 1% for 800mV <sub>p-p</sub> single-ended output swing.

Table 1-1: Pin Descriptions (Continued)

Pin Number	Name	Timing	Type	Description
K2	CD_VDD	–	Power	Power supply connection for the serial digital cable driver. Connect to +1.8V DC analog.
K3, K4	SDO, $\overline{\text{SDO}}$	Analog	Output	Serial digital loop-through output signal operating at 1.485Gb/s, 1.485/1.001Gb/s, or 270Mb/s. The slew rate of these outputs is automatically controlled to meet SMPTE 292M and 259M requirements according to the setting of the SD/HD pin.
K5	CD_GND	–	Power	Ground connection for the serial digital cable driver. Connect to analog GND.
K6	JTAG/ $\overline{\text{HOST}}$	Non Synchronous	Input	CONTROL SIGNAL INPUT Signal levels are LVCMOS/LVTTL compatible. Used to select JTAG Test Mode or Host Interface Mode. When set HIGH, $\overline{\text{CS}}_{\text{TMS}}$ , $\overline{\text{SDOUT\_TDO}}$ , $\overline{\text{SDI\_TDI}}$ and $\overline{\text{SCLK\_TCK}}$ are configured for JTAG boundary scan testing. When set LOW, $\overline{\text{CS}}_{\text{TMS}}$ , $\overline{\text{SDOUT\_TDO}}$ , $\overline{\text{SDI\_TDI}}$ and $\overline{\text{SCLK\_TCK}}$ are configured as GSPI pins for normal host interface operation.
K7	F	Synchronous with PCLK	Output	STATUS SIGNAL OUTPUT Signal levels are LVCMOS/LVTTL compatible. Used to indicate the ODD / EVEN field of the video signal. The F signal will be HIGH for the entire period of field 2 as indicated by the F bit in the received TRS signals. The F signal will be LOW for all lines in field 1 and for all lines in progressive scan systems.

## 2. Electrical Characteristics

### 2.1 Absolute Maximum Ratings

Parameter	Value/Units
Supply Voltage Core	-0.3V to +2.1V
Supply Voltage I/O	-0.3V to +4.6V
Input Voltage Range (any input)	-2.0V to + 5.25V
Ambient Operating Temperature	-20°C ≤ T <sub>A</sub> ≤ 85°C
Storage Temperature	-40°C ≤ T <sub>STG</sub> ≤ 125°C
Junction to Case Thermal Resistance, θ <sub>J-C</sub>	10.4°C/W
Junction to Air Thermal Resistance, θ <sub>J-a</sub> (at zero airflow)	37.1°C/W
ESD Protection On All Pins	1kV

NOTES:

1. MIL STD 883 ESD protection applied to all pins on the device.

### 2.2 DC Electrical Characteristics

**Table 2-1: DC Electrical Characteristics**

T<sub>A</sub> = 0°C to 70°C, unless otherwise specified.

Parameter	Symbol	Conditions	Min	Typ	Max	Units	Test Level	Notes
<b>System</b>								
Operation Temperature Range	T <sub>A</sub>	–	0	–	70	°C	3	1
Digital Core Supply Voltage	CORE_VDD	–	1.71	1.8	1.89	V	3	1
Digital I/O Supply Voltage	IO_VDD	–	3.13	3.3	3.47	V	3	1
Charge Pump Supply Voltage	CP_VDD	–	3.13	3.3	3.47	V	3	1
Phase Detector Supply Voltage	PD_VDD	–	1.71	1.8	1.89	V	3	1
Input Buffer Supply Voltage	BUFF_VDD	–	1.71	1.8	1.89	V	3	1
Cable Driver Supply Voltage	CD_VDD	–	1.71	1.8	1.89	V	3	1
External VCO Supply Voltage Output	VCO_VCC	–	2.25	–	2.75	V	1	–
+1.8V Supply Current	I <sub>1V8</sub>	SDO Enabled	–	–	245	mA	3	4



**Table 2-1: DC Electrical Characteristics (Continued)**T<sub>A</sub> = 0°C to 70°C, unless otherwise specified.

Parameter	Symbol	Conditions	Min	Typ	Max	Units	Test Level	Notes
+3.3V Supply Current	I <sub>3V3</sub>	–	–	–	55	mA	3	5
Total Device Power	P <sub>D</sub>	SDO Enabled	–	–	550	mW	3	–
	P <sub>D</sub>	SDO Disabled	–	–	450	mW	3	–
<b>Digital I/O</b>								
Input Logic LOW	V <sub>IL</sub>	–	–	–	0.8	V	4	–
Input Logic HIGH	V <sub>IH</sub>	–	2.1	–	–	V	4	–
Output Logic LOW	V <sub>OL</sub>	+8mA	–	0.2	0.4	V	4	–
Output Logic HIGH	V <sub>OH</sub>	-8mA	IO_VDD - 0.4	–	–	V	4	–
<b>Input</b>								
Input Bias Voltage	V <sub>B</sub>	–	–	1.45	–	V	1	2
RSET Voltage	V <sub>RSET</sub>	RSET=281Ω	0.54	0.6	0.66	V	1	3
<b>Output</b>								
Output Common Mode Voltage	V <sub>CMOUT</sub>	75Ω load, RSET=281Ω, SD and HD	0.8	1.0	1.2	V	1	–

**TEST LEVELS**

1. Production test at room temperature and nominal supply voltage with guardbands for supply and temperature ranges.
2. Production test at room temperature and nominal supply voltage with guardbands for supply and temperature ranges using correlated test.
3. Production test at room temperature and nominal supply voltage.
4. QA sample test.
5. Calculated result based on Level 1, 2, or 3.
6. Not tested. Guaranteed by design simulations.
7. Not tested. Based on characterization of nominal parts.
8. Not tested. Based on existing design/characterization data of similar product.
9. Indirect test.

**NOTES**

1. All DC and AC electrical parameters within specification.
2. Input common mode is set by internal biasing resistors.
3. Set by the value of the RSET resistor.
4. Sum of all 1.8V supplies.
5. Sum of all 3.3V supplies.

## 2.3 AC Electrical Characteristics

**Table 2-2: AC Electrical Characteristics**

$T_A = 0^\circ\text{C}$  to  $70^\circ\text{C}$ , unless otherwise shown

Parameter	Symbol	Conditions	Min	Typ	Max	Units	Test Level	Notes
<b>System</b>								
Serial Digital Input Jitter Tolerance	IJT	Nominal loop bandwidth	0.6	–	–	UI	1	1
Master Mode Asynchronous Lock Time		No data to HD	–	–	468	us	6,7	2
		HD to SD	–	–	260	us	6,7	2
		HD to DVB-ASI	–	–	135	us	6,7	2
		No data to SD	–	–	340	us	6,7	2
		SD to HD	–	–	256	us	6,7	2
		SD to DVB-ASI	–	–	173	us	6,7	2
		No data to DVB-ASI	–	–	65	us	6,7	2
		DVB-ASI to SD	–	–	227	us	6,7	2
Slave Mode Asynchronous Lock Time		No data to HD	–	–	240	us	6,7	2
		No data to SD	–	–	197	us	6,7	2
		No data to DVB-ASI	–	–	68	us	6,7	2
Device Latency		10-bit SD	–	21	–	PCLK	8	–
		20-bit HD	–	19	–	PCLK	8	–
		DVB-ASI	–	11	–	PCLK	8	–
Reset Pulse Width	$t_{\text{reset}}$	–	1	–	–	ms	8	4
<b>Serial Digital Differential Input</b>								
Serial Input Data Rate	$DR_{\text{DDI}}$	–	–	1.485	–	Gb/s	1	–
		–	–	1.485/1.001	–	Gb/s	9	–
		–	–	270	–	Mb/s	1	–
Serial Digital Input Signal Swing	$\Delta V_{\text{DDI}}$	Differential with internal $100\Omega$ input termination	200	600	1000	$\text{mV}_{\text{p-p}}$	1	–
<b>Serial Digital Output</b>								
Serial Output Data Rate	$DR_{\text{SDO}}$	–	–	1.485	–	Gb/s	1	–
		–	–	1.485/1.001	–	Gb/s	9	–
		–	–	270	–	Mb/s	1	–
Serial Output Swing	$\Delta V_{\text{SDO}}$	RSET = $281\Omega$ Load = $75\Omega$	650	800	950	$\text{mV}_{\text{p-p}}$	1	–
Serial Output Rise Time 20% ~ 80%	$tr_{\text{SDO}}$	HD signal	–	–	260	ps	1	–
		SD signal	400	550	1500	ps	1	–
Serial Output Fall Time 20% ~ 80%	$tf_{\text{SDO}}$	HD signal	–	–	260	ps	1	–
		SD signal	400	550	1500	ps	1	–

**Table 2-2: AC Electrical Characteristics (Continued)**T<sub>A</sub> = 0°C to 70°C, unless otherwise shown

Parameter	Symbol	Conditions	Min	Typ	Max	Units	Test Level	Notes
Serial Output Intrinsic Jitter	t <sub>IJ</sub>	Pseudorandom and pathological HD signal	–	90	125	ps	5	3
		Pseudorandom and pathological SD signal	–	270	350	ps	5	3
<b>Parallel Output</b>								
Parallel Clock Frequency	f <sub>PCLK</sub>	–	13.5	–	148.5	MHz	4	–
Parallel Clock Duty Cycle	DC <sub>PCLK</sub>	–	40	50	60	%	4	–
Output Data Hold Time	t <sub>OH</sub>	20-bit HD, 15pF	1.0	–	–	ns	4	–
		10-bit SD, 15pF	19.5	–	–	ns	8	–
Output Data Delay Time	t <sub>OD</sub>	20-bit HD, 15pF	–	–	4.5	ns	4	–
		10-bit SD, 15pF	–	–	22.8	ns	8	–
Output Data Rise/Fall Time	tr/tf	–	–	–	1.5	ns	3	–
<b>GSPI</b>								
GSPI Input Clock Frequency	f <sub>SCLK</sub>	–	–	–	6.6	MHz	8	–
GSPI Input Clock Duty Cycle	DC <sub>SCLK</sub>	–	40	–	60	%	8	–
GSPI Input Data Setup Time	–	–	0	–	–	ns	8	–
GSPI Input Data Hold Time	–	–	–	–	1.43	ns	8	–
GSPI Output Data Hold Time	–	–	2.1	–	–	ns	8	–
GSPI Output Data Delay Time	–	–	–	–	7.27	ns	8	–

## TEST LEVELS

1. Production test at room temperature and nominal supply voltage with guardbands for supply and temperature ranges.
2. Production test at room temperature and nominal supply voltage with guardbands for supply and temperature ranges using correlated test.
3. Production test at room temperature and nominal supply voltage.
4. QA sample test.
5. Calculated result based on Level 1, 2, or 3.
6. Not tested. Guaranteed by design simulations.
7. Not tested. Based on characterization of nominal parts.
8. Not tested. Based on existing design/characterization data of similar product.
9. Indirect test.

## NOTES

1. 6MHz sinewave modulation.
2. HD = 1080i, SD = 525i
3. Serial Digital Output Reclocked (RC\_BYP = HIGH).
4. See Section 4.15, Figure 4-16.

## 2.4 Solder Reflow Profiles

The GS1559 is available in a Pb or Pb-free package. It is recommended that the Pb package be soldered with Pb paste using the Standard Eutectic profile shown in Figure 2-1, and the Pb-free package be soldered with Pb-free paste using the reflow profile shown in Figure 2-2.

NOTE: It is possible to solder a Pb-free package with Pb paste using a Standard Eutectic profile with a reflow temperature maintained at 245-250°C.

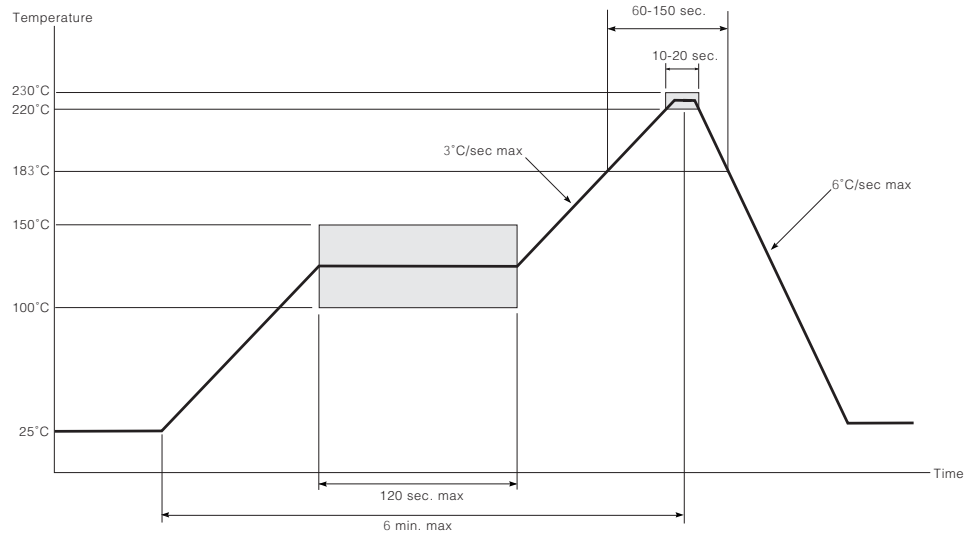

**Figure 2-1: Standard Eutectic Solder Reflow Profile (Pb package, Pb paste)**

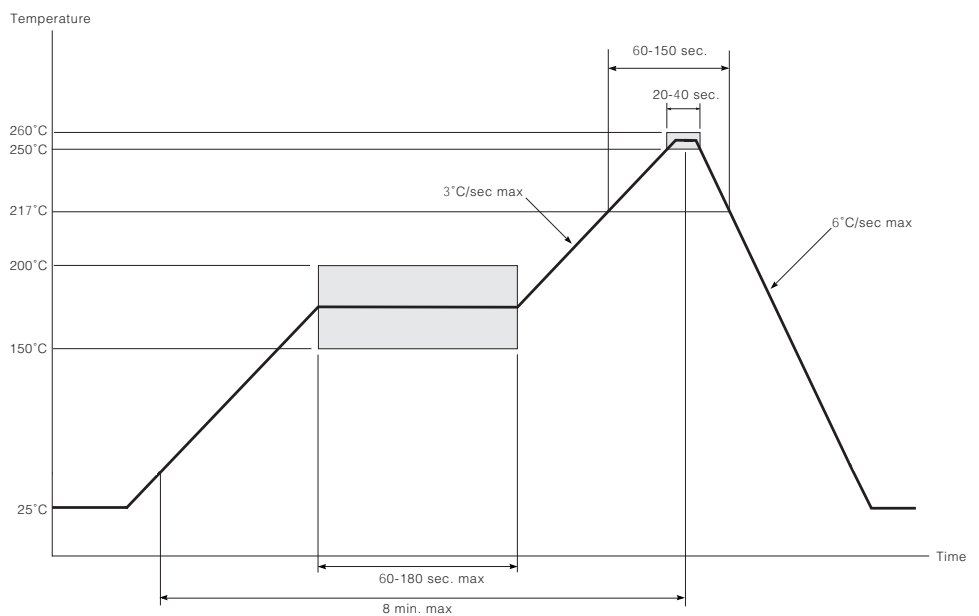

**Figure 2-2: Maximum Pb-free Solder Reflow Profile (Pb-free package, Pb-free paste)**

### 3. Input/Output Circuits

All resistors in ohms, all capacitors in farads, unless otherwise shown.

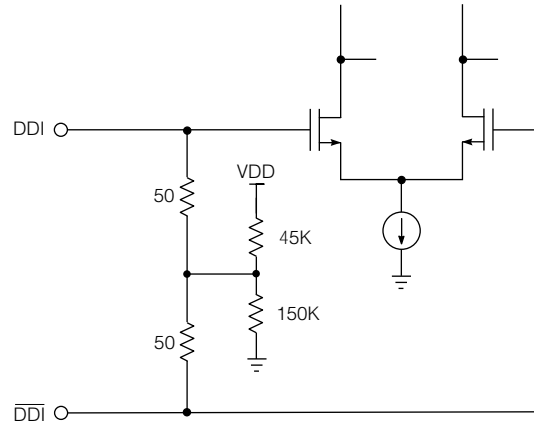

**Figure 3-1: Serial Digital Input**

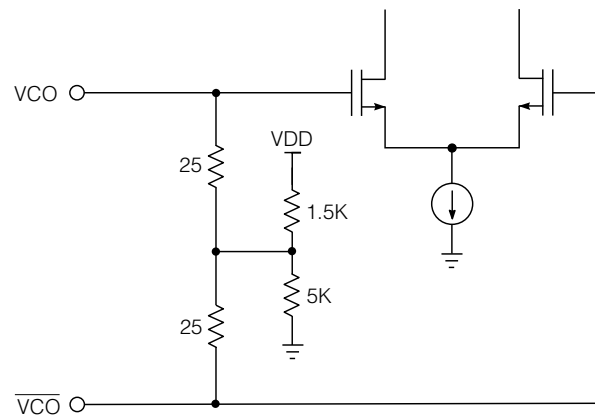

**Figure 3-2: VCO Input**

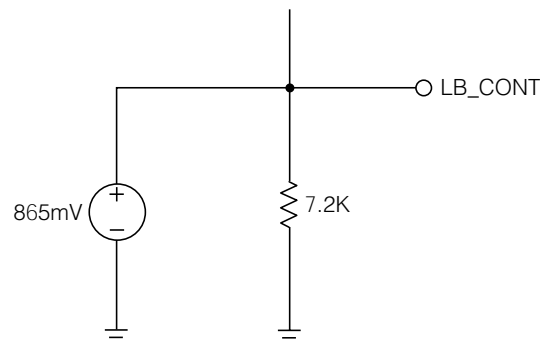

**Figure 3-3: PLL Loop Bandwidth Control**

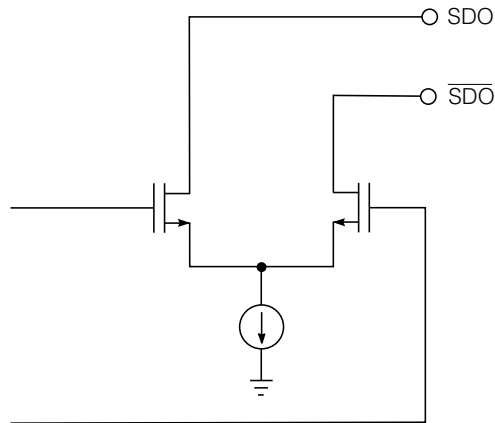

Figure 3-4: Serial Digital Output

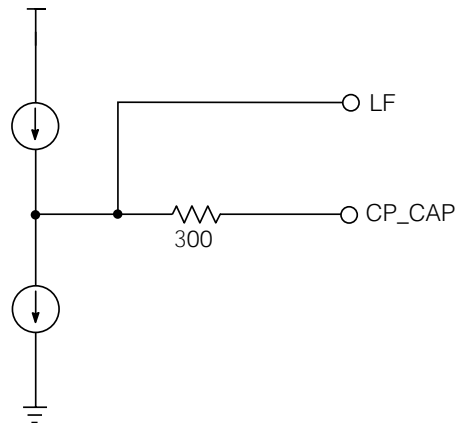

Figure 3-5: VCO Control Output & PLL Lock Time Capacitor

### 3.1 Host Interface Map

REGISTER NAME	ADDRESS	15	14	13	12	11	10	9	8	7	6	5	4	3	2	1	0
ERROR_MASK	014h	Not Used	Not Used	Not Used	Not Used	Not Used	VD_STD_ ERR_ MASK	FF_CRC_ ERR_ MASK	AP_CRC_ ERR_ MASK	LOCK_ ERR_ MASK	CCS_ERR_IM ASK	YCS_ERR_IM ASK	CORC_ ERR_ MASK	YORC_ ERR_ MASK	LNUM_ERR_ MASK	SAV_ERR_IM ASK	EAV_ERR_IM ASK
FF_LINE_END_F1	019h	Not Used	Not Used	Not Used	Not Used	Not Used	Not Used	b9	b8	b7	b6	b5	b4	b3	b2	b1	b0
FF_LINE_START_F1	018h	Not Used	Not Used	Not Used	Not Used	Not Used	Not Used	b9	b8	b7	b6	b5	b4	b3	b2	b1	b0
FF_LINE_END_F0	017h	Not Used	Not Used	Not Used	Not Used	Not Used	Not Used	b9	b8	b7	b6	b5	b4	b3	b2	b1	b0
FF_LINE_START_F0	016h	Not Used	Not Used	Not Used	Not Used	Not Used	Not Used	b9	b8	b7	b6	b5	b4	b3	b2	b1	b0
AP_LINE_END_F1	015h	Not Used	Not Used	Not Used	Not Used	Not Used	Not Used	b9	b8	b7	b6	b5	b4	b3	b2	b1	b0
AP_LINE_START_F1	014h	Not Used	Not Used	Not Used	Not Used	Not Used	Not Used	b9	b8	b7	b6	b5	b4	b3	b2	b1	b0
AP_LINE_END_F0	013h	Not Used	Not Used	Not Used	Not Used	Not Used	Not Used	b9	b8	b7	b6	b5	b4	b3	b2	b1	b0
AP_LINE_START_F0	012h	Not Used	Not Used	Not Used	Not Used	Not Used	Not Used	b9	b8	b7	b6	b5	b4	b3	b2	b1	b0
RASTER_STRUCTURE4	011h	Not Used	Not Used	Not Used	Not Used	Not Used	Not Used	b10	b8	b7	b6	b5	b4	b3	b2	b1	b0
RASTER_STRUCTURE3	010h	Not Used	Not Used	Not Used	Not Used	Not Used	b10	b9	b8	b7	b6	b5	b4	b3	b2	b1	b0
RASTER_STRUCTURE2	00Fh	Not Used	Not Used	Not Used	Not Used	b11	b10	b9	b8	b7	b6	b5	b4	b3	b2	b1	b0
RASTER_STRUCTURE1	00Eh	Not Used	Not Used	Not Used	Not Used	b11	b10	b9	b8	b7	b6	b5	b4	b3	b2	b1	b0
VIDEO_FORMAT_OUT_B	00Dh	VFO4-b7	VFO4-b6	VFO4-b5	VFO4-b4	VFO4-b3	VFO4-b2	VFO4-b1	VFO4-h0	VFO3-b7	VFO3-b6	VFO3-b5	VFO3-b4	VFO3-h3	VFO3-h2	VFO3-b1	VFO3-h0
VIDEO_FORMAT_OUT_A	00Ch	VFO2-b7	VFO2-b6	VFO2-b5	VFO2-b4	VFO2-b3	VFO2-b2	VFO2-b1	VFO2-h0	VFO1-b7	VFO1-b6	VFO1-b5	VFO1-b4	VFO1-h3	VFO1-h2	VFO1-b1	VFO1-h0
	00Bh																
	00Ah																
ANC_TYPE5	009h	b15	b14	b13	b12	b11	b10	b9	b8	b7	b6	b5	b4	b3	b2	b1	b0
ANC_TYPE4	008h	b15	b14	b13	b12	b11	b10	b9	b8	b7	b6	b5	b4	b3	b2	b1	b0
ANC_TYPE3	007h	b15	b14	b13	b12	b11	b10	b9	b8	b7	b6	b5	b4	b3	b2	b1	b0
ANC_TYPE2	006h	b15	b14	b13	b12	b11	b10	b9	b8	b7	b6	b5	b4	b3	b2	b1	b0
ANC_TYPE1	005h	b15	b14	b13	b12	b11	b10	b9	b8	b7	b6	b5	b4	b3	b2	b1	b0
VIDEO_STANDARD	004h	Not Used	VDS-b4	VDS-b3	VDS-b2	VDS-b1	VDS-h0	INT_PROG	STD_ LOCK	CDF-b3	CDF-b2	CDF-b1	CDF-h0	YDF-b3	YDF-b2	YDF-b1	YDF-h0
EDH_FLAG	003h	Not Used	ANC-UES	ANC-IDA	ANC-IDH	ANC-EDA	ANC-EDH	FF-UES	FF-IDA	FF-IDH	FF-EDA	FF-EDH	AP-UES	AP-IDA	AP-IDH	AP-EDA	AP-EDH
	002h																
ERROR_STATUS	001h	Not Used	Not Used	Not Used	Not Used	Not Used	VD_STD_ ERR	FF_CRC_ ERR	AP_CRC_ ERR	LOCK_ ERR	CCS_ERR	YCS_ERR	CORC_ ERR	YORC_ ERR	LNUM_ERR	SAV_ERR	EAV_ERR
IOPROC_DISABLE	000h	Not Used	Not Used	Not Used	Not Used	Not Used	Not Used	Not Used	H_CONFIG	Not Used	Not Used	ILLEGAL_RE MAP	EDH_CRC_ NS	ANC_ CSUM_INS	CRC_INS	LNUM_INS	TRS_INS

### 3.1.1 Host Interface Map (R/W Configurable Registers)

REGISTER NAME	ADDRESS	15	14	13	12	11	10	9	8	7	6	5	4	3	2	1	0
ERROR_MASK	01A0h						VD_STD_ERR_MASK	FF_CRC_ERR_MASK	AP_CRC_ERR_MASK	LOCK_ERR_MASK	CCS_ERR_MASK	YCS_ERR_MASK	CCRC_ERR_MASK	YCRC_ERR_MASK	LNUM_ERR_MASK	SAV_ERR_MASK	EAV_ERR_MASK
FF_LINE_END_F1	0190h							b9	b8	b7	b6	b5	b4	b3	b2	b1	b0
FF_LINE_START_F1	0180h							b9	b8	b7	b6	b5	b4	b3	b2	b1	b0
FF_LINE_END_F0	0170h							b9	b8	b7	b6	b5	b4	b3	b2	b1	b0
FF_LINE_START_F0	0160h							b9	b8	b7	b6	b5	b4	b3	b2	b1	b0
AP_LINE_END_F1	0150h							b9	b8	b7	b6	b5	b4	b3	b2	b1	b0
AP_LINE_START_F1	0140h							b9	b8	b7	b6	b5	b4	b3	b2	b1	b0
AP_LINE_END_F0	0130h							b9	b8	b7	b6	b5	b4	b3	b2	b1	b0
AP_LINE_START_F0	0120h							b9	b8	b7	b6	b5	b4	b3	b2	b1	b0
	0110h																
	0100h																
	00F0h																
	00E0h																
	00D0h																
	00C0h																
	00B0h																
	00A0h																
ANC_TYPE5	0090h	b15	b14	b13	b12	b11	b10	b9	b8	b7	b6	b5	b4	b3	b2	b1	b0
ANC_TYPE4	0080h	b15	b14	b13	b12	b11	b10	b9	b8	b7	b6	b5	b4	b3	b2	b1	b0
ANC_TYPE3	0070h	b15	b14	b13	b12	b11	b10	b9	b8	b7	b6	b5	b4	b3	b2	b1	b0
ANC_TYPE2	0060h	b15	b14	b13	b12	b11	b10	b9	b8	b7	b6	b5	b4	b3	b2	b1	b0
ANC_TYPE1	0050h	b15	b14	b13	b12	b11	b10	b9	b8	b7	b6	b5	b4	b3	b2	b1	b0
	0040h																
	0030h																
	0020h																
	0010h																
IOPROC_DISABLE	0000h								H_CONFIG		ILLEGAL_REMAP	EDH_CRC_NS	ANC_CSUMM_INS	CRC_INS	LNUM_INS	TRS_INS	



**3.1.2 Host Interface Map (Read Only Registers)**

REGISTER NAME	ADDRESS	15	14	13	12	11	10	9	8	7	6	5	4	3	2	1	0
	01Ah																
	019h																
	018h																
	017h																
	016h																
	015h																
	014h																
	013h																
	012h																
RASTER_STRUCTURE4	011h						b10	b9	b8	b7	b6	b5	b4	b3	b2	b1	b0
RASTER_STRUCTURE3	010h						b10	b9	b8	b7	b6	b5	b4	b3	b2	b1	b0
RASTER_STRUCTURE2	00Fh						b10	b9	b8	b7	b6	b5	b4	b3	b2	b1	b0
RASTER_STRUCTURE1	00Eh					b11	b10	b9	b8	b7	b6	b5	b4	b3	b2	b1	b0
VIDEO_FORMAT_OUT_B	00Dh	VFO4-b7	VFO4-b6	VFO4-b5	VFO4-b4	VFO4-b3	VFO4-b2	VFO4-b1	VFO4-b0	VFO3-b7	VFO3-b6	VFO3-b5	VFO3-b4	VFO3-b3	VFO3-b2	VFO3-b1	VFO3-b0
VIDEO_FORMAT_OUT_A	00Ch	VFO2-b7	VFO2-b6	VFO2-b5	VFO2-b4	VFO2-b3	VFO2-b2	VFO2-b1	VFO2-b0	VFO1-b7	VFO1-b6	VFO1-b5	VFO1-b4	VFO1-b3	VFO1-b2	VFO1-b1	VFO1-b0
	00Bh																
	00Ah																
	009h																
	008h																
	007h																
	006h																
	005h																
VIDEO_STANDARD	004h		VDS-b4	VDS-b3	VDS-b2	VDS-b1	VDS-b0	INT_PROG	STD_	CDF-b3	CDF-b2	CDF-b1	CDF-b0	YDF-b3	YDF-b2	YDF-b1	YDF-b0
									LOCK								
EDH_FLAG	003h		ANC-UES	ANC-IDA	ANC-IDH	ANC-EDA	ANC-EDH	FF-UES	FF-IDA	FF-IDH	FF-EDA	FF-EDH	AP-UES	AP-IDA	AP-IDH	AP-EDA	AP-EDH
	002h																
ERROR_STATUS	001h			VD_STD_		FF_CRC_	AP_CRC_	LOCK_		YCRC_	CCS_ERR	YCS_ERR	CCRC_	YCRC_	LNUM_ERR	SAV_ERR	EAV_ERR
				ERR		ERR	ERR	ERR		ERR	ERR	ERR	ERR	ERR			
	000h																

## 4. Detailed Description

### 4.1 Functional Overview

The GS1559 is a multi-rate reclocking deserializer with an integrated serial digital loop-through output. When used in conjunction with the multi-rate GS1574 Adaptive Cable Equalizer and the external GO1525 Voltage Controlled Oscillator, a receive solution at 1.485Gb/s, 1.485/1.001Gb/s or 270Mb/s is realized.

The device has two basic modes of operation which determine precisely how SMPTE or DVB-ASI compliant input data streams are reclocked and processed.

In master mode, ( $\overline{\text{MASTER/SLAVE}} = \text{HIGH}$ ), the GS1559 will automatically detect, reclock, deserialize and process SD SMPTE 259M-C, HD SMPTE 292M, or DVB-ASI input data.

In slave mode, ( $\overline{\text{MASTER/SLAVE}} = \text{LOW}$ ), the application layer must set external device pins for the correct reception of either SMPTE or DVB-ASI data. Slave mode also supports the reclocking and deserializing of data not conforming to SMPTE or DVB-ASI streams.

The provided serial loop-through outputs may be selected as either buffered or reclocked versions of the input signal and feature a high impedance mode, output mute on loss of signal and adjustable signal swing.

In the digital signal processing core, several data processing functions are implemented including error detection and correction and automatic video standards detection. These features are all enabled by default, but may be individually disabled via internal registers accessible through the GSPI host interface.

Finally, the GS1559 contains a JTAG interface for boundary scan test implementations.

### 4.2 Serial Digital Input

The GS1559 contains two current mode differential serial digital input buffers, allowing the device to be connected to two SMPTE 259M-C or 292M compliant input signals.

Both input buffers have internal  $50\Omega$  termination resistors which are connected to ground via the TERM1 and TERM2 pins. The input common mode level is set by internal biasing resistors such that the serial digital input signals must be AC coupled into the device. Genum recommends using a capacitor value of 4.7uF to accommodate pathological signals.

The input buffers use a separate power supply of +1.8V DC supplied via the BUFF\_VDD and PDBUFF\_GND pins.

### 4.2.1 Input Signal Selection

A 2x1 input multiplexer is provided to allow the application layer to select between the two serial digital input streams using a single external pin. When IP\_SEL is set HIGH, serial digital input 1 (DDI1 /  $\overline{\text{DDI1}}$ ) is selected as the input to the GS1559's reclocker stage. When IP\_SEL is set LOW, serial digital input 2 (DDI2 /  $\overline{\text{DDI2}}$ ) is selected.

### 4.2.2 Carrier Detect Input

For each of the differential inputs, an associated carrier detect input signal is included, ( $\overline{\text{CD1}}$  and  $\overline{\text{CD2}}$ ). These signals are generated by Gennum's family of automatic cable equalizers.

When LOW,  $\overline{\text{CDx}}$  indicates that a valid serial digital data stream is being delivered to the GS1559 by the equalizer. When HIGH, the serial digital input to the device should be considered invalid. If no equalizer precedes the device, the application layer should set  $\overline{\text{CD1}}$  and  $\overline{\text{CD2}}$  accordingly.

A 2x1 input multiplexer is also provided for these signals. The internal carrier\_detect signal is determined by the setting of the IP\_SEL pin and is used by the lock detect block of the GS1559 to determine the lock status of the device, (see [Section 4.6.1](#)).

### 4.2.3 Single Input Configuration

If the application requires a single differential input, the second set of inputs may be left unconnected. Tie the associated carrier detect pin HIGH, and leave the termination pin unconnected.

## 4.3 Serial Digital Reclocker

The output of the 2x1 serial digital input multiplexer passes to the GS1559's internal reclocker stage. The function of this block is to lock to the input data stream, extract a clean clock, and retime the serial digital data to remove high frequency jitter.

The reclocker was designed with a 'hexabang' phase and frequency detector. That is, the PFD used can identify six 'degrees' of phase / frequency misalignment between the input data stream and the clock signal provided by the VCO, and correspondingly signal the charge pump to produce six different control voltages. This results in fast and accurate locking of the PLL to the data stream.

In master mode, the operating center frequency of the reclocker is toggled between 270Mb/s and 1.485Gb/s by the lock detect block, (see [Section 4.6.1](#)). In slave mode, however, the center frequency is determined entirely by the SD/HD input control signal set by the application layer.

If lock is achieved, the reclocker provides an internal pll\_lock signal to the lock detect block of the device.

### 4.3.1 External VCO

The GS1559 requires the external GO1525 Voltage Controlled Oscillator as part of the reclocker's phase-locked loop. This external VCO implementation was chosen to ensure high quality reclocking.

Power for the external VCO is generated entirely by the GS1559 from an integrated voltage regulator. The internal regulator uses +3.3V DC supplied via the CP\_VDD / CP\_GND pins to provide +2.5V DC on the VCO\_VCC / VCO\_GND pins.

The control voltage to the VCO is output from the GS1559 on the LF pin and requires 4.7k $\Omega$  pull-up and pull-down resistors to ensure correct operation.

The GO1525 produces a 1.485GHz reference signal for the reclocker, input on the VCO pin of the GS1559. Both LF and VCO signals should be referenced to the supplied VCO\_GND as shown in the recommended application circuit of [Section 5.1](#).

### 4.3.2 Loop Bandwidth

The loop bandwidth of the integrated reclocker is nominally 1.4MHz, but may be increased or decreased via the LB\_CONT pin. It is recommended that this pin be connected to VCO\_GND through 39.2k $\Omega$  to maximize the input jitter tolerance of the device.

## 4.4 Serial Digital Loop-Through Output

The GS1559 contains an integrated current mode differential serial digital cable driver with automatic slew rate control. When enabled, this serial digital output provides an active loop-through of the input signal.

The integrated cable driver uses a separate power supply of +1.8V DC supplied via the CD\_VDD and CD\_GND pins.

To enable the loop-through output,  $\overline{\text{SDO\_EN/DIS}}$  must be set HIGH by the application layer. Setting the  $\overline{\text{SDO\_EN/DIS}}$  signal LOW will cause the SDO and  $\overline{\text{SDO}}$  output pins to become high impedance, resulting in reduced device power consumption.

Gennum recommends using the GS1528A SDI Dual Slew-Rate Cable Driver to meet SMPTE specifications.

### 4.4.1 Output Swing

Nominally, the voltage swing of the serial digital loop-through output is  $800\text{mV}_{\text{p-p}}$  single-ended into a  $75\Omega$  load. This is set externally by connecting the RSET pin to CD\_VDD through  $281\Omega$ .

The loop-through output swing may be decreased by increasing the value of the RSET resistor. The relationship is approximated by the curve shown in [Figure 4-1](#).

Alternatively, the serial digital output can drive  $800\text{mV}_{\text{p-p}}$  into a  $50\Omega$  load. Since the output swing is reduced by a factor of approximately one third when the smaller load is used, the RSET resistor must be  $187\Omega$  to obtain  $800\text{mV}_{\text{p-p}}$ .

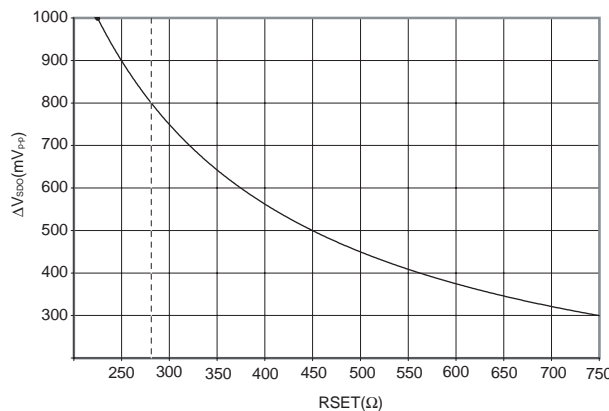

**Figure 4-1: Serial Digital Loop-Through Output Swing**

### 4.4.2 Reclocker Bypass Control

The serial digital loop-through output may be either a buffered version of the serial digital input signal, or a reclocked version of that signal.

When operating in slave mode, the application layer may choose the reclocked output by setting  $\overline{\text{RC\_BYP}}$  to logic HIGH. If  $\overline{\text{RC\_BYP}}$  is set LOW, the data stream will bypass the internal reclocker and the serial digital output will be a buffered version of the input.

When operating in master mode, the device will assert the  $\overline{\text{RC\_BYP}}$  pin HIGH only when it has successfully locked to a SMPTE or DVB-ASI input data stream, (see [Section 4.6.1](#)). In this case, the serial digital loop-through output will be a reclocked version of the input.

### 4.4.3 Serial Digital Output Mute

The GS1559 will automatically mute the serial digital loop-through output in both master and slave modes when the internal carrier\_detect signal indicates an invalid serial input.

The loop-through output will also be muted in slave mode when  $\overline{\text{SDO}}/\overline{\text{SDO}}$  is selected as reclocked, ( $\overline{\text{RC\_BYP}} = \text{HIGH}$ ), but the lock detect block has failed to lock to the data stream, ( $\text{LOCKED} = \text{LOW}$ ).

Table 4-1 summarizes the possible states of the serial digital loop-through output data stream.

**Table 4-1: Serial Digital Loop-Through Output Status**

<b>SLAVE MODE</b>			
<b>SDO</b>	<b><math>\overline{\text{CD}}</math></b>	<b>LOCKED</b>	<b><math>\overline{\text{RC\_BYP}}</math> (INPUT)</b>
RECLOCKED	LOW	HIGH	HIGH
BUFFERED	LOW	X	LOW
MUTED	LOW	LOW	HIGH
MUTED	HIGH	LOW*	X
<b>MASTER MODE</b>			
<b>SDO</b>	<b><math>\overline{\text{CD}}</math></b>	<b>LOCKED</b>	<b><math>\overline{\text{RC\_BYP}}</math> (OUTPUT)</b>
RECLOCKED	LOW	HIGH	HIGH
BUFFERED	LOW	LOW	LOW
MUTED	HIGH	LOW*	LOW

\*NOTE: LOCKED = HIGH if and only if  $\overline{\text{CD}} = \text{LOW}$

## 4.5 Serial-To-Parallel Conversion

The retimed data and phase-locked clock signals from the reclocker are fed to the serial-to-parallel converter. The function of this block is to extract 10-bit or 20-bit parallel data words from the reclocked serial data stream and present them to the SMPTE and DVB-ASI word alignment blocks simultaneously.

## 4.6 Modes Of Operation

The GS1559 has two basic modes of operation which determine how the lock detect block controls the integrated reclocker. Master mode is enabled when the application layer sets the MASTER/SLAVE pin HIGH, and slave mode is enabled when MASTER/SLAVE is set LOW.

### 4.6.1 Lock Detect

The lock detect block controls the center frequency of the integrated reclocker to ensure lock to the received serial digital data stream is achieved, and indicates via the LOCKED output pin that the device has detected the appropriate sync words. In Data through mode the detection for appropriate sync words is turned off. The locked pin is an indication of analog lock.

Lock detection is a continuous process, which begins at device power up or after a system reset, and continues until the device is powered down or held in reset.

The lock detection algorithm first determines if a valid serial digital input signal has been presented to the device by sampling the internal carrier\_detect signal. As described in [Section 4.2.2](#), this signal will be LOW when a good serial digital input signal has been detected.

If the carrier\_detect signal is HIGH, the serial data into the device is considered invalid, and the VCO frequency will be set to the center of the pull range. The LOCKED pin will be LOW and all outputs of the device except for the PCLK output will be muted. Instead, the PCLK output frequency will operate within +/-3% of the rates shown in [Table 4-16](#) of [Section 4.11.5](#).

NOTE: When the device is operating in DVB-ASI slave mode only, the parallel outputs will not mute when the carrier\_detect signal is HIGH. The LOCKED signal will function normally.

If a valid input signal has been detected, and the device is in master mode, the lock algorithm will enter a hunt phase where four attempts are made to detect the presence of either SMPTE TRS sync words or DVB-ASI sync words. At each attempt, the center frequency of the reclocker will be toggled between 270Mb/s and 1.485Gb/s.

Assuming that a valid SMPTE or DVB-ASI signal has been applied to the device, asynchronous lock times will be as listed in [Table 2-2: AC Electrical Characteristics](#).

In slave mode, the application layer fixes the center frequency of the reclocker such that the lock algorithm will attempt to lock within the single data rate determined by the setting of the SD/HD pin. Asynchronous lock times are also listed in the [Table 2-2: AC Electrical Characteristics](#).

NOTE: The PCLK output will continue to operate during the lock detection process. The frequency may toggle between 148MHz and 27MHz when the 20bit/10bit pin is set LOW, or between 74MHz and 13.5MHz when 20bit/10bit is set HIGH.

For SMPTE and DVB-ASI inputs, the lock detect block will only assert the LOCKED output signal HIGH if (1) the reclocker has locked to the input data stream as indicated by the internal pll\_lock signal, and (2) TRS or DVB-ASI sync words have been correctly identified.

If after four attempts lock has not been achieved, the lock detection algorithm will enter into PLL lock mode. In this mode, the reclocker will attempt to lock to the input data stream without detecting SMPTE TRS or DVB-ASI sync words. This unassisted process can take up to 10ms to achieve lock.

When reclocker lock as indicated by the internal pll\_lock signal is achieved in this mode, one of the following will occur:

1. In slave mode, data will be passed directly to the parallel outputs without any further processing taking place and the LOCKED signal will be asserted HIGH if and only if the SMPTE\_BYPASS and DVB\_ASI input pins are set LOW; or
2. In master mode, the LOCKED signal will be asserted LOW, the parallel outputs will be latched to logic LOW, and the SMPTE\_BYPASS and DVB\_ASI output signals will also be set LOW.

## 4.6.2 Master Mode

Recall that the GS1559 is said to be in master mode when the MASTER/SLAVE input signal is set HIGH. In this case, the following four device pins become output status signals:

- $\overline{\text{SMPTE\_BYPASS}}$
- DVB\_ASI
- SD/HD
- $\overline{\text{RC\_BYP}}$

The combined setting of these four pins will indicate whether the device has locked to valid SMPTE or DVB-ASI data at SD or HD rates. Table 4-2 shows the possible combinations.

## 4.6.3 Slave Mode

The GS1559 is said to be in slave mode when the MASTER/SLAVE input signal is set LOW. In this case, the four device pins listed in Section 4.6.2 become input control signals.

It is required that the application layer set the first three inputs to reflect the appropriate input data format ( $\overline{\text{SMPTE\_BYPASS}}$ , DVB\_ASI, and SD/HD). If just one of these three is configured incorrectly, the device will not lock to the input data stream, and the  $\overline{\text{DATA\_ERROR}}$  pin will be set LOW.

The fourth input signal,  $\overline{\text{RC\_BYP}}$ , allows the application layer to determine whether the serial digital loop-through output will be a reclocked or buffered version of the input, (see Section 4.4.2). Table 4-3 shows the required settings for various input formats.



**Table 4-2: Master Mode Output Status Signals**

FORMAT	PIN SETTINGS			
	$\overline{\text{SMPTE\_BYPASS}}$	DVB_ASI	SD/HD	$\overline{\text{RC\_BYP}}$
HD SMPTE	HIGH	LOW	LOW	HIGH
SD SMPTE	HIGH	LOW	HIGH	HIGH
DVB-ASI	LOW	HIGH	HIGH	HIGH
NOT SMPTE OR DVB-ASI*	LOW	LOW	HIGH OR LOW	LOW

\*NOTE: When the device locks to the data stream in PLL lock mode, the parallel outputs will be latched LOW, and the serial loop-through output will be a buffered version of the input.

**Table 4-3: Slave Mode Input Control Signals**

FORMAT	PIN SETTINGS		
	$\overline{\text{SMPTE\_BYPASS}}$	DVB_ASI	SD/HD
HD SMPTE	HIGH	LOW	LOW
SD SMPTE	HIGH	LOW	HIGH
DVB-ASI	LOW	HIGH	HIGH
NOT SMPTE OR DVB-ASI*	LOW	LOW	HIGH OR LOW

\*NOTE: See [Section 4.9](#) for a complete description of Data Through mode.

## 4.7 SMPTE Functionality

The GS1559 is said to be in SMPTE mode once the device has detected SMPTE TRS sync words and locked to the input data stream as described in [Section 4.6.1](#). The device will remain in SMPTE mode until such time that SMPTE TRS sync words fail to be detected.

The lock detect block may also drop out of SMPTE mode under the following conditions:

- $\overline{\text{RESET\_TRST}}$  is asserted LOW
- $\overline{\text{CDx}}$  is HIGH
- $\overline{\text{SMPTE\_BYPASS}}$  is asserted LOW in slave mode
- $\text{DVB\_ASI}$  is asserted HIGH in slave mode

TRS word detection is a continuous process and both 8-bit and 10-bit TRS words will be identified by the device in both SD and HD modes.

In master mode, the GS1559 sets the  $\overline{\text{SMPTE\_BYPASS}}$  pin HIGH and the  $\text{DVB\_ASI}$  pin LOW to indicate that it has locked to a SMPTE input data stream. When operating in slave mode, the application layer must assert the  $\text{DVB\_ASI}$  pin LOW and the  $\overline{\text{SMPTE\_BYPASS}}$  pin HIGH in order to enable SMPTE operation.

### 4.7.1 SMPTE Descrambling and Word Alignment

After serial-to-parallel conversion, the internal 10-bit or 20-bit data bus is fed to the SMPTE descramble and word alignment block. The function of this block is to carry out NRZI-to-NRZ decoding, descrambling according to SMPTE 259M or 292M, and word alignment of the data to the TRS sync words.

Word alignment occurs when two consecutive valid TRS words (SAV and EAV inclusive) with the same bit alignment have been detected.

In normal operation, re-synchronization of the word alignment process will only take place when two consecutive identical TRS word positions have been detected. When automatic or manual switch line lock handling is 'actioned', (see [Section 4.7.3](#)), word alignment re-synchronization will occur on the next received TRS code word.

### 4.7.2 Internal Flywheel

The GS1559 has an internal flywheel which is used in the generation of internal / external timing signals, in the detection and correction of certain error conditions and in automatic video standards detection. It is only operational in SMPTE mode.

The flywheel consists of a number of counters and comparators operating at video pixel and video line rates. These counters maintain information about the total line length, active line length, total number of lines per field / frame, and total active lines per field / frame for the received video stream.

The flywheel 'learns' the video standard by timing the horizontal and vertical reference information contained in the TRS ID words of the received video stream. Full synchronization of the flywheel to the received video standard therefore requires one complete video frame.

Once synchronization has been achieved, the flywheel will continue to monitor the received TRS timing information to maintain synchronization.

The  $\overline{\text{FW\_EN/DIS}}$  input pin controls the synchronization mechanism of the flywheel. When this input signal is LOW, the flywheel will re-synchronize all pixel and line based counters on every received TRS ID word.

When  $\overline{\text{FW\_EN/DIS}}$  is held HIGH, re-synchronization of the pixel and line based counters will only take place when a consistent synchronization error has been detected. Two consecutive video lines with identical TRS timing different to the current flywheel timing must occur to initiate re-synchronization of the counters. This provides a measure of noise immunity to internal and external timing signal generation.

The flywheel will be disabled should the LOCKED signal or the  $\overline{\text{RESET\_TRST}}$  signal be LOW. A LOW to HIGH transition on either signal will cause the flywheel to re-acquire synchronization on the next received TRS word, regardless of the setting of the  $\overline{\text{FW\_EN/DIS}}$  pin.

### 4.7.3 Switch Line Lock Handling

The principal of switch line lock handling is that the switching of synchronous video sources will only disturb the horizontal timing and alignment of the stream, whereas the vertical timing remains in synchronization.

To account for the horizontal disturbance caused by a synchronous switch, it is necessary to re-synchronize the flywheel immediately after the switch has taken place. Rapid re-synchronization of the GS1559 to the new video standard can be achieved by controlling the flywheel using the  $\overline{\text{FW\_EN/DIS}}$  pin.

At every PCLK cycle the device samples the  $\overline{\text{FW\_EN/DIS}}$  pin. When a logic LOW to HIGH transition at this pin is detected anywhere within the active line, the flywheel will re-synchronize immediately to the next TRS word. This is shown in [Figure 4-2](#).

To ensure switch line lock handling, the  $\overline{\text{FW\_EN/DIS}}$  signal should be LOW for a minimum of one PCLK cycle (maximum one video line) anywhere within the active portion of the line on which the switch has taken place.

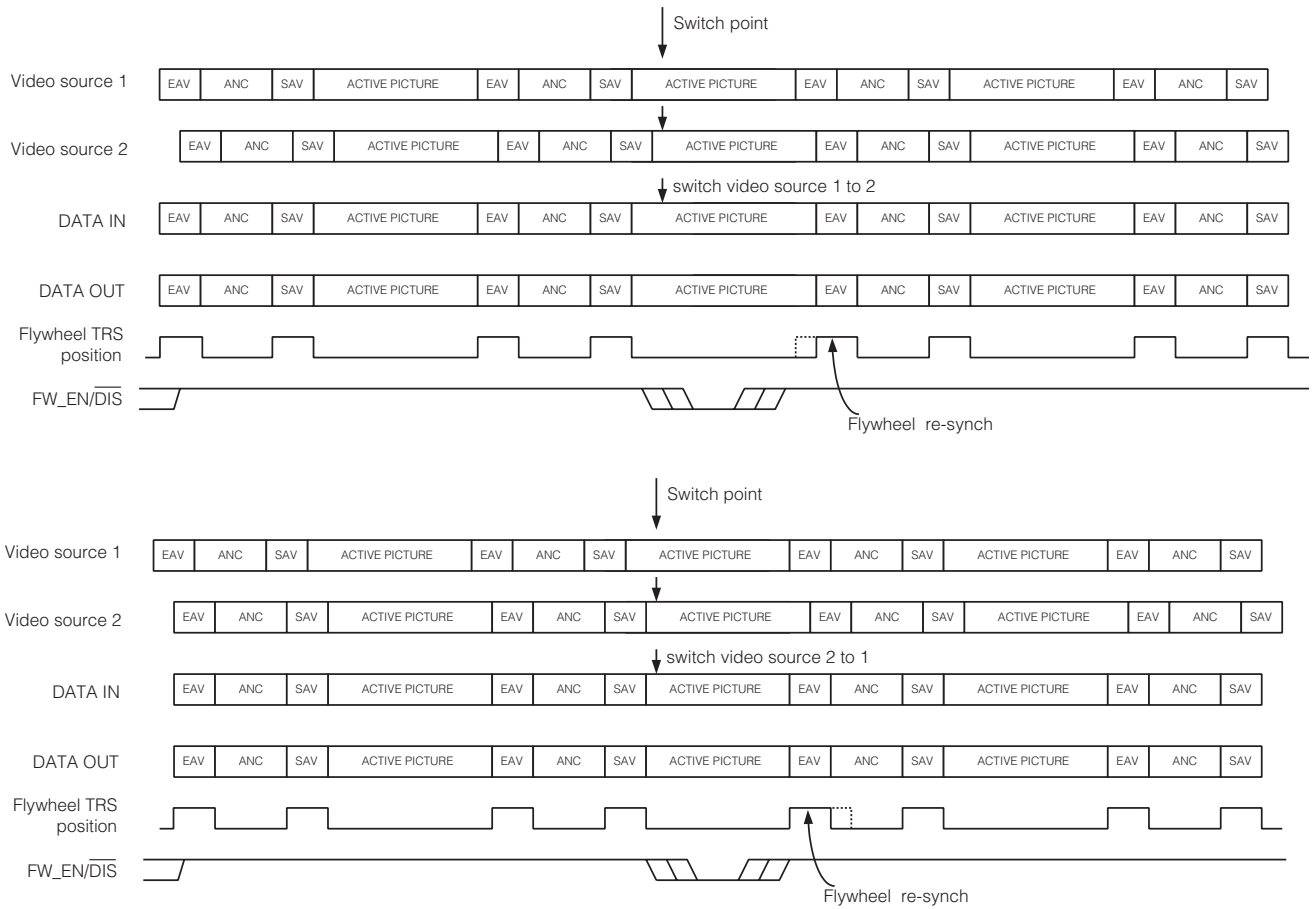

**Figure 4-2: Switch Line Locking**

The ability to manually re-synchronize the flywheel is also important when switching asynchronous sources or to implement other non-standardized video switching functions.

The GS1559 also implements automatic switch line lock handling. By utilizing the synchronous switch points defined by SMPTE RP168 for all major video standards with the automatic video standards detect function, the device automatically re-synchronizes the flywheel at the switch point.

This function will occur regardless of the setting of the FW\_EN/DIS pin.

The switch line is defined as follows:

- For 525 line interlaced systems: re-sync takes place at the end of lines 10 & 273.
- For 525 line progressive systems: re-sync takes place at the end of line 10.
- For 625 line interlaced systems: re-sync takes place at the end of lines 6 & 319.
- For 625 line progressive systems: re-sync takes place at the end of line 6.

- For 750 line progressive systems: re-sync takes place at the end of line 7.
- For 1125 line interlaced systems: re-sync takes place at the end of lines 7 & 568.
- For 1125 line progressive systems: re-sync takes place at the end of line 7.

A full list of all major video standards and switching lines is shown in [Table 4-4](#).

NOTE 1: The flywheel timing will define the line count such that the line numbers shown in [Table 4-4](#) may not correspond directly to the digital line counts.

NOTE 2: Unless indicated by SMPTE 352M payload identifier packets, the GS1559 will not distinguish between 50/60 frames PsF and 25/30 frames interlaced for the 1125 line video systems; 24 PsF will be identified.

**Table 4-4: Switch Line Position for Digital Systems**

System	Video Format	Sampling	Signal Standard	Parallel Interface	Serial Interface	Switch Line No.
HD-SDTI	1920x1080 (PsF)	4:2:2	274M	274M + 348M	292M	7
	1920x1080 (2:1)	4:2:2	274M	274M + 348M	292M	7, 569
	1280x720 (1:1)	4:2:2	296M	296M + 348M	292M	7
SDTI	720x576/50 (2:1)	4:2:2	BT.656	BT.656 + 305M	259M	6, 319
	720x483/59.94 (2:1)	4:2:2	125M	125M + 305M	259M	10, 273
750	1280x720/60 (1:1)	4:2:2	296M	296M	296M	7
	1280x720/50 (1:1)	4:2:2	296M	296M	296M	7
	1280x720/30 (1:1)	4:2:2	296M	296M	296M	7
	1280x720/25 (1:1)	4:2:2	296M	296M	296M	7
	1280x720/24 (1:1)	4:2:2	296M	296M	296M	7
1125	1920x1080/60 (1:1)	4:2:2	274M + RP211	274M + RP211	292M	7
	1920x1080/50 (1:1)	4:2:2	274M + RP211	274M + RP211	292M	7
	1920x1080/30 (1:1)	4:2:2	274M + RP211	274M + RP211	292M	7
	1920x1080/25 (1:1)	4:2:2	274M + RP211	274M + RP211	292M	7
	1920x1080/24 (1:1)	4:2:2	274M + RP211	274M + RP211	292M	7
	1920x1080/30 (PsF)	4:2:2	274M + RP211	274M + RP211	292M	7
	1920x1080/25 (PsF)	4:2:2	274M + RP211	274M + RP211	292M	7
	1920x1080/24 (PsF)	4:2:2	274M + RP211	274M + RP211	292M	7
	1920x1080/60 (2:1)	4:2:2	274M + RP211	274M + RP211	292M	7, 569
	1920x1080/50 (2:1)	4:2:2	274M + RP211	274M + RP211	292M	7, 569

**Table 4-4: Switch Line Position for Digital Systems (Continued)**

System	Video Format	Sampling	Signal Standard	Parallel Interface	Serial Interface	Switch Line No.
525	960x483/59.94 (2:1)	4:2:2	267M	349M	292M	10, 273
	960x483/59.94 (2:1)	4:2:2	267M	267M	259M	10, 273
	720x483/59.94 (2:1)	4:4:4:4	267M	349M	292M	10, 273
	720x483/59.94 (2:1)	4:4:4:4	267M	347M	344M	10, 273
	720x483/59.94 (2:1)	4:4:4:4	267M	RP174	344M	10, 273
	720x483/59.94 (2:1)	4:4:4:4	267M	RP175	RP175	10, 273
	720x483/59.94 (2:1)	4:2:2	125M	349M	292M	10, 273
	720x483/59.94 (2:1)	4:2:2	125M	125M	259M	10, 273
	720x483/59.94 (1:1)	4:2:2	293M	349M	292M	10
	720x483/59.94 (1:1)	4:2:2	293M	347M	344M	10
	720x483/59.94 (1:1)	4:2:2	293M	293M	294M	10
	720x483/59.94 (1:1)	4:2:0	293M	349M	292M	10
	720x483/59.94 (1:1)	4:2:0	293M	293M	294M	10
	625	720x576/50 (1:1)	4:2:2	BT.1358	349M	292M
720x576/50 (1:1)		4:2:2	BT.1358	347M	344M	6
720x576/50 (1:1)		4:2:2	BT.1358	BT.1358	BT.1362	6
720x576/50 (1:1)		4:2:0	BT.1358	349M	292M	6
720x576/50 (1:1)		4:2:0	BT.1358	BT.1358	BT.1362	6
960x576/50 (2:1)		4:2:2	BT.601	349M	292M	6, 319
960x576/50 (2:1)		4:2:2	BT.601	BT.656	259M	6, 319
720x576/50 (2:1)		4:4:4:4	BT.799	349M	292M	6, 319
720x576/50 (2:1)		4:4:4:4	BT.799	347M	344M	6, 319
720x576/50 (2:1)		4:4:4:4	BT.799	BT.799	344M	6, 319
720x576/50 (2:1)		4:4:4:4	BT.799	BT.799	–	6, 319
720x576/50 (2:1)		4:2:2	BT.601	349M	292M	6, 319
720x576/50 (2:1)		4:2:2	BT.601	125M	259M	6, 319

#### 4.7.4 HVF Timing Signal Generation

The GS1559 extracts critical timing parameters from either the received TRS signals ( $\overline{FW\_EN/DIS} = \text{LOW}$ ), or from the internal flywheel-timing generator ( $\overline{FW\_EN/DIS} = \text{HIGH}$ ).

Horizontal blanking period (H), vertical blanking period (V), and even / odd field (F) timing are all extracted and presented to the application layer via the H:V:F status output pins.

The H signal timing is configurable via the H\_CONFIG bit of the internal IOPROC\_DISABLE register as either active line based blanking, or TRS based blanking, (see [Section 4.10.6](#)).

Active line based blanking is enabled when the H\_CONFIG bit is set LOW. In this mode, the H output is HIGH for the entire horizontal blanking period, including the EAV and SAV TRS words. This is the default H timing used by the device.

When H\_CONFIG is set HIGH, TRS based blanking is enabled. In this case, the H output will be HIGH for the entire horizontal blanking period as indicated by the H bit in the received TRS ID words.

The timing of these signals is shown in [Figure 4-3](#).

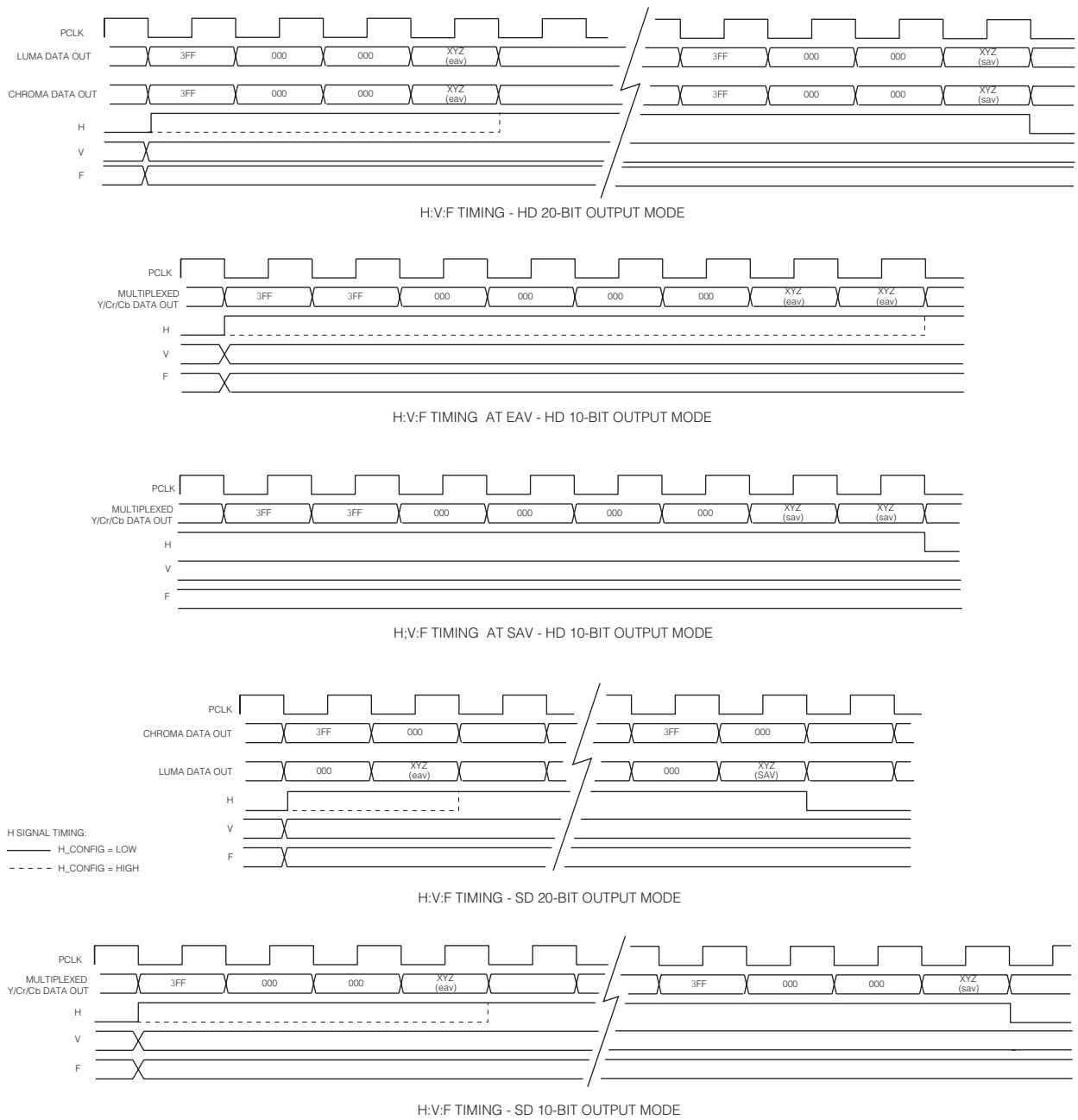

**Figure 4-3: H, V, F Timing**



## 4.8 DVB-ASI Functionality

The GS1559 is said to be in DVB-ASI mode once the device has detected 32 consecutive DVB-ASI words without a single word or disparity error being generated. The device will remain in DVB-ASI mode until 32 consecutive DVB-ASI word or disparity errors are detected, or until SMPTE TRS ID words have been detected.

The lock detect block may also drop out of DVB-ASI mode under the following conditions:

- $\overline{\text{RESET\_TRST}}$  is asserted LOW
- $\overline{\text{CDx}}$  is HIGH
- $\overline{\text{SMPTE\_BYPASS}}$  is asserted HIGH in slave mode
- $\text{DVB\_ASI}$  is asserted LOW in slave mode

K28.5 sync patterns in the received DVB-ASI data stream will be detected by the device in either inverted or non-inverted form.

In master mode, the GS1559 sets the  $\overline{\text{SMPTE\_BYPASS}}$  pin LOW and the  $\text{DVB\_ASI}$  pin HIGH to indicate that it has locked to a DVB-ASI input data stream. When operating in slave mode, the application layer must set the  $\text{SD/HD}$  pin HIGH, in addition to setting  $\overline{\text{SMPTE\_BYPASS}}$  LOW and  $\text{DVB\_ASI}$  HIGH, in order to enable DVB-ASI operation.

### 4.8.1 DVB-ASI 8b/10b Decoding and Word Alignment

After serial-to-parallel conversion, the internal 10-bit data bus is fed to the DVB-ASI 8b/10b decode and word alignment block. The function of this block is to word align the data to the K28.5 sync characters, and 8b/10b decode and bit-swap the data to achieve bit alignment with the data outputs.

The extracted 8-bit data will be presented to  $\text{DOUT}[17:10]$ , bypassing all internal SMPTE mode data processing.

NOTE: When operating in DVB-ASI mode,  $\text{DOUT}[9:0]$  are forced LOW.

### 4.8.2 Status Signal Outputs

In DVB-ASI mode, the  $\text{DOUT}19$  and  $\text{DOUT}18$  pins will be configured as DVB-ASI status signals  $\text{SYNCOUT}$  and  $\text{WORDERR}$  respectively.

$\text{SYNCOUT}$  will be HIGH whenever a K28.5 sync character is present on the output. This output may be used to drive the write enable signal of an external FIFO, thus providing a means of removing the K28.5 sync characters from the data stream. Parallel DVB-ASI data may then be clocked out of the FIFO at some rate less than 27MHz. See [Figure 4-4](#).

$\text{WORDERR}$  will be high whenever the device has detected a running disparity error or illegal code word.

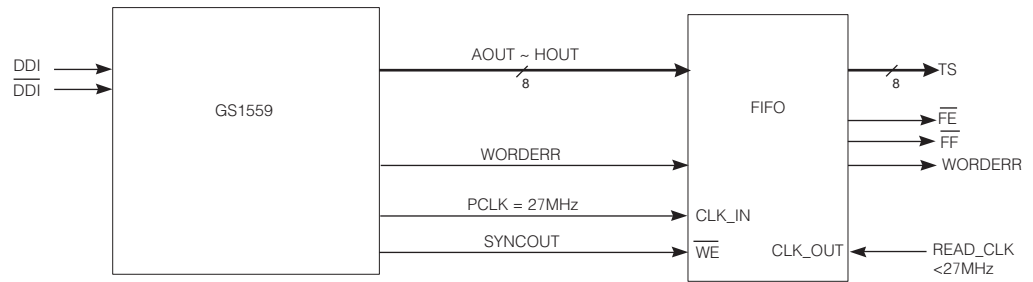

Figure 4-4: DVB-ASI FIFO Implementation Using The GS1559

## 4.9 Data Through Mode

The GS1559 may be configured by the application layer to operate as a simple serial-to-parallel converter. In this mode, the device presents data to the output data bus without performing any decoding, descrambling or word-alignment.

Data through mode is enabled only when the  $\overline{\text{MASTER/SLAVE}}$ ,  $\overline{\text{SMPTE\_BYPASS}}$ , and DVB\_ASI input pins are set LOW. Under these conditions, the lock detection algorithm enters PLL lock mode, (see [Section 4.6.1](#)), such that the device may relock data not conforming to SMPTE or DVB-ASI streams. The LOCKED pin will indicate analog lock.

When operating in master mode, the GS1559 will set the  $\overline{\text{SMPTE\_BYPASS}}$  and DVB\_ASI signals to logic LOW if presented with a data stream without SMPTE TRS ID words or DVB-ASI sync words. The LOCKED and data bus outputs will be forced LOW and the serial digital loop-through output will be a buffered version of the input.

## 4.10 Additional Processing Functions

The GS1559 contains an additional data processing block which is available in SMPTE mode only, (see [Section 4.7](#)).

### 4.10.1 FIFO Load Pulse

To aid in the application-specific implementation of auto-phasing and line synchronization functions, the GS1559 will generate a FIFO load pulse to reset line-based FIFO storage.

The  $\overline{\text{FIFO\_LD}}$  output pin will normally be HIGH but will go LOW for one PCLK period, thereby generating a FIFO write reset signal.

The FIFO load pulse will be generated such that it is co-timed to the SAV XYZ code word presented to the output data bus. This ensures that the next PCLK cycle will correspond to the first active sample of the video line.

[Figure 4-5](#) shows the timing relationship between the  $\overline{\text{FIFO\_LD}}$  signal and the output video data.

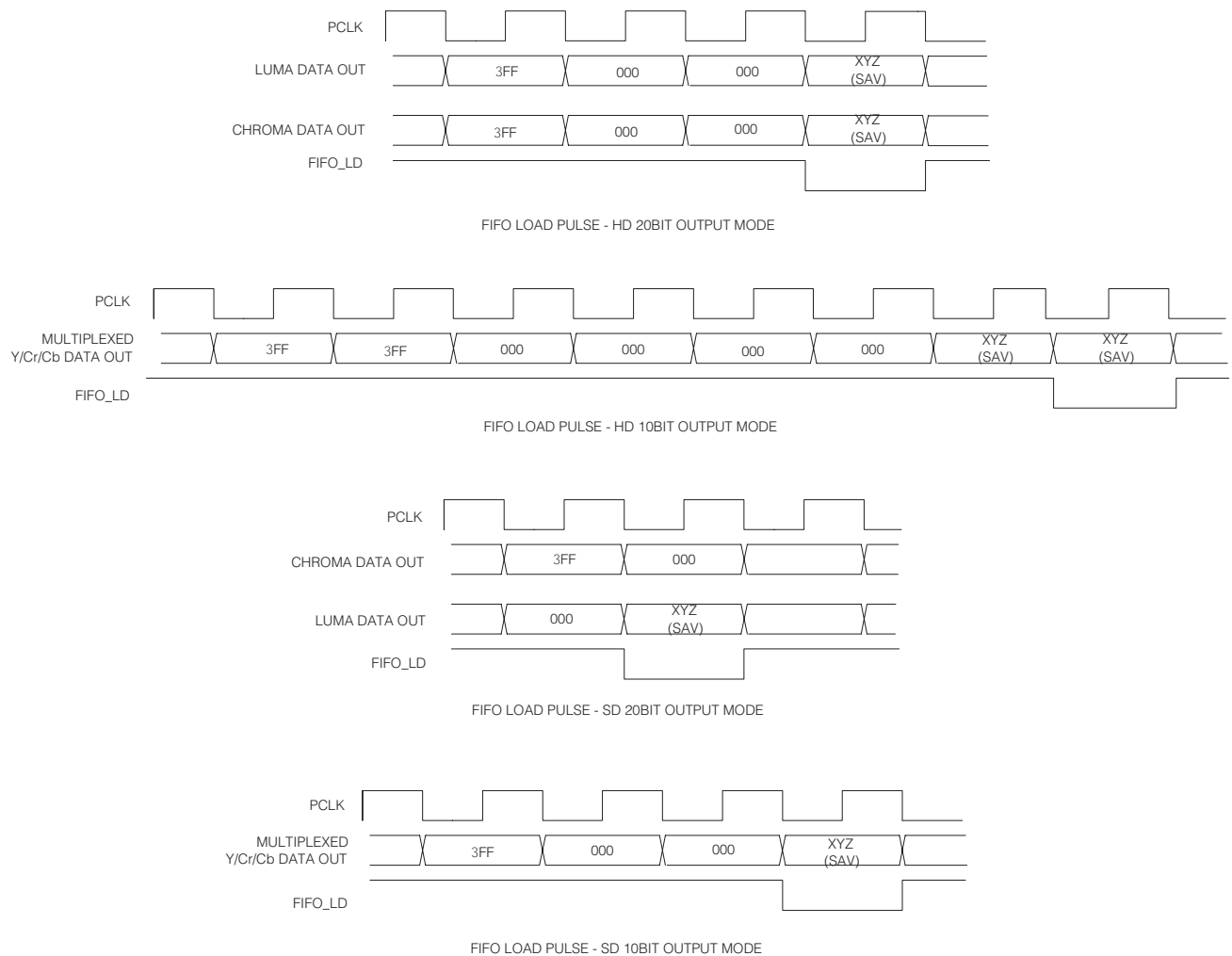

**Figure 4-5: FIFO\_LD Pulse Timing**

### 4.10.2 Ancillary Data Detection and Indication

The GS1559 will detect all types of ancillary data in either the vertical or horizontal blanking spaces and indicate via the status signal output pins YANC and CANC the position of ancillary data in the output data stream. These status signal outputs are synchronous with PCLK and can be used as clock enables to external logic, or as write enables to an external FIFO or other memory device.

When operating in HD mode, ( $\overline{SD/HD} = \text{LOW}$ ), the YANC signal will be HIGH whenever ancillary data is detected in the luma data stream, and the CANC signal will be HIGH whenever ancillary data is detected in the chroma data stream.

In SD mode, ( $\overline{SD/HD} = \text{HIGH}$ ), the YANC and CANC signal operation will depend on the output data format. For 20-bit demultiplexed data, (see Section 4.11), the YANC and CANC signals will operate independently. However, for 10-bit multiplexed data, the YANC and CANC signals will both be HIGH whenever ancillary data is detected.

The signals will be HIGH from the start of the ancillary data preamble and will remain HIGH until after the ancillary data checksum.

The operation of the YANC and CANC signals is shown in Figure 4-6.

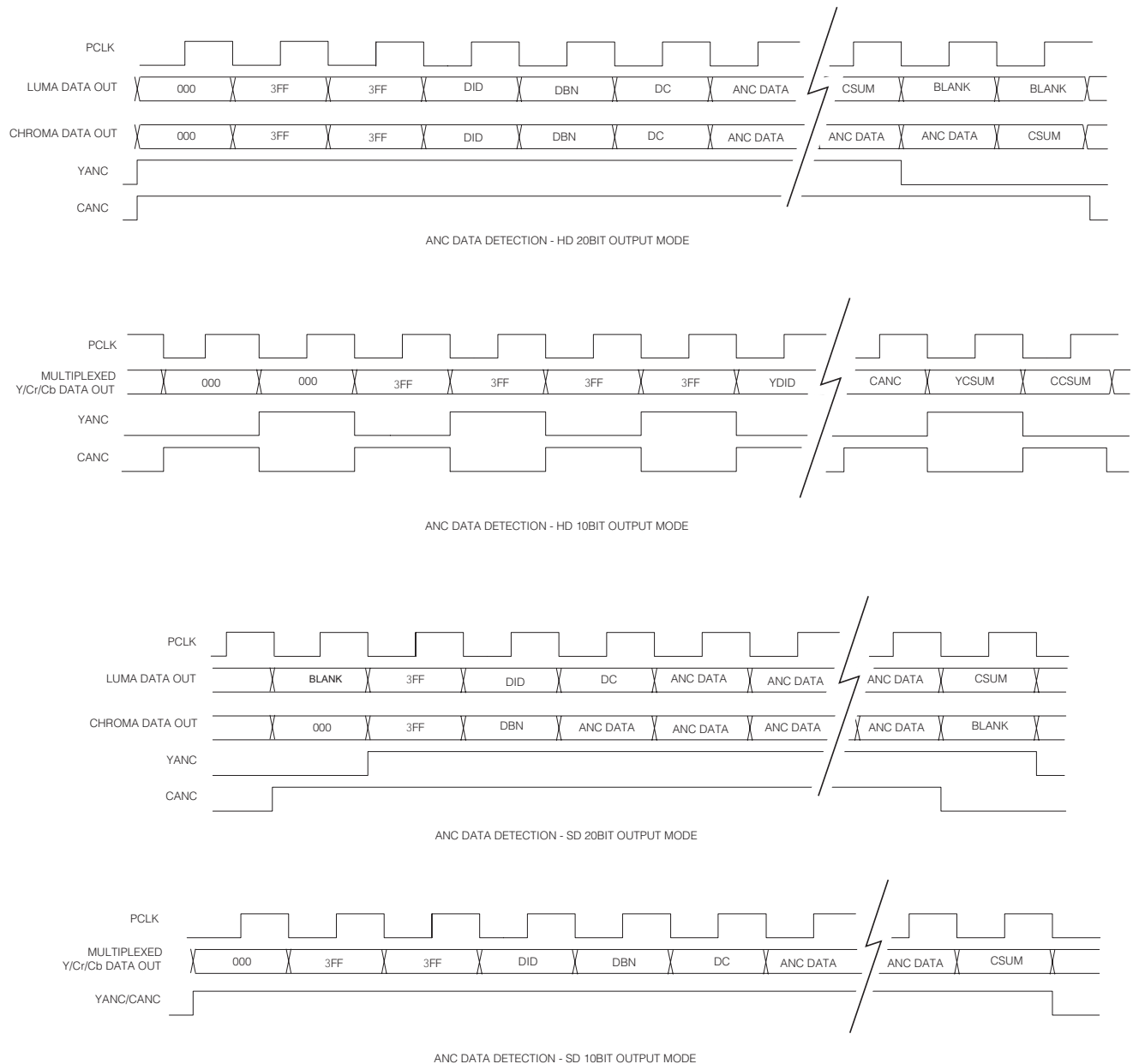

**Figure 4-6: YANC and CANC Output Signal Timing**

#### 4.10.2.1 Programmable Ancillary Data Detection

Although the GS1559 will detect all types of ancillary data by default, it also allows the host interface to specifically program up to five different ancillary data types for detection. This is accomplished via the ANC\_TYPE register ([Table 4-5](#)).

For each data type to be detected, the host interface must program the DID and/or SDID of the ancillary data type of interest. The GS1559 will compare the received DID and/or SDID with the programmed values and assert YANC and CANC only if an exact match is found.

If any DID or SDID value is set to zero in the ANC\_TYPE register, no comparison or match will be made for that value. For example, if the DID is programmed but the SDID is set to zero, the device will detect all ancillary data types matching the DID value, regardless of the SDID.

In the case where all five DID and SDID values are set to zero, the GS1559 will detect all ancillary data types. This is the default setting after device reset.

Where one or more, but less than five, DID and/or SDID values have been programmed, then only those matching ancillary data types will be detected and indicated.

NOTE 1: The GS1559 will always detect EDH ancillary data packets for EDH error detection purposes, regardless of which DID/SDID values have been programmed for ancillary data indication, (see [Section 4.10.5.2](#)).

NOTE 2: See SMPTE 291M for a definition of ancillary data terms.

**Table 4-5: Host Interface Description for Programmable Ancillary Data Type Registers**

Register Name	Bit	Name	Description	R/W	Default
ANC_TYPE1 Address: 005h	15-8	ANC_TYPE1[15:8]	Used to program the DID for ancillary data detection at the YANC and CANC output	R/W	0
	7-0	ANC_TYPE1[7:0]	Used to program the SDID for ancillary data detection at the YANC and CANC output.  Should be set to zero if no SDID is present in the ancillary data packet to be detected.	R/W	0
ANC_TYPE2 Address: 006h	15-8	ANC_TYPE2[15:8]	Used to program the DID for ancillary data detection at the YANC and CANC output	R/W	0
	7-0	ANC_TYPE2[7:0]	Used to program the SDID for ancillary data detection at the YANC and CANC output.  Should be set to zero if no SDID is present in the ancillary data packet to be detected.	R/W	0
ANC_TYPE3 Address: 007h	15-8	ANC_TYPE3[15:8]	Used to program the DID for ancillary data detection at the YANC and CANC output	R/W	0
	7-0	ANC_TYPE3[7:0]	Used to program the SDID for ancillary data detection at the YANC and CANC output.  Should be set to zero if no SDID is present in the ancillary data packet to be detected.	R/W	0
ANC_TYPE4 Address: 008h	15-8	ANC_TYPE4[15:8]	Used to program the DID for ancillary data detection at the YANC and CANC output	R/W	0
	7-0	ANC_TYPE4[7:0]	Used to program the SDID for ancillary data detection at the YANC and CANC output.  Should be set to zero if no SDID is present in the ancillary data packet to be detected.	R/W	0
ANC_TYPE5 Address: 009h	15-8	ANC_TYPE5[15:8]	Used to program the DID for ancillary data detection at the YANC and CANC output	R/W	0
	7-0	ANC_TYPE5[7:0]	Used to program the SDID for ancillary data detection at the YANC and CANC output.  Should be set to zero if no SDID is present in the ancillary data packet to be detected.	R/W	0

### 4.10.3 SMPTE 352M Payload Identifier

The GS1559 can receive and detect the presence of the SMPTE 352M payload identifier ancillary data packet. This four word payload identifier packet may be used to indicate the transport mechanism, frame rate and line scanning / sampling structure.

Upon reception of this packet, the device will extract the four words describing the video format being transported and make this information available to the host interface via the four VIDEO\_FORMAT\_OUT registers (Table 4-6).

The VIDEO\_FORMAT\_OUT registers will only be updated if the received checksum is the same as the locally calculated checksum.

These registers will be cleared to zero, indicating an undefined format, if the device loses lock to the input data stream (LOCKED = LOW), or if the SMPTE\_BYPASS pin is asserted LOW. This is also the default setting after device reset.

The SMPTE 352M packet should be received once per field for interlaced systems and once per frame for progressive systems. If the packet is not received for two complete video frames, the VIDEO\_FORMAT\_OUT registers will be cleared to zero.

**Table 4-6: Host Interface Description for SMPTE 352M Payload Identifier Registers**

Register Name	Bit	Name	Description	R/W	Default
VIDEO_FORMAT_OUT_B Address: 00Dh	15-8	SMPTE352M Byte 4	Data will be available in this register when Video Payload Identification Packets are detected in the data stream.	R	0
	7-0	SMPTE352M Byte 3	Data will be available in this register when Video Payload Identification Packets are detected in the data stream.	R	0
VIDEO_FORMAT_OUT_A Address: 00Ch	15-8	SMPTE352M Byte 2	Data will be available in this register when Video Payload Identification Packets are detected in the data stream.	R	0
	7-0	SMPTE352M Byte 1	Data will be available in this register when Video Payload Identification Packets are detected in the data stream.	R	0

### 4.10.4 Automatic Video Standard and Data Format Detection

The GS1559 can independently detect the input video standard and data format by using the timing parameters extracted from the received TRS ID words. This information is presented to the host interface via the VIDEO\_STANDARD register (Table 4-7).

Total samples per line, active samples per line, total lines per field/frame and active lines per field/frame are also calculated and presented to the host interface via the RASTER\_STRUCTURE registers (Table 4-8). These line and sample count registers are updated once per frame at the end of line 12. This is in addition to the information contained in the VIDEO\_STANDARD register.

After device reset, the four RASTER\_STRUCTURE registers default to zero.

#### 4.10.4.1 Video Standard Indication

The video standard codes reported in the VD\_STD[4:0] bits of the VIDEO\_STANDARD register represent the SMPTE standards as shown in [Table 4-9](#).

In addition to the 5-bit video standard code word, the VIDEO\_STANDARD register also contains two status bits. The STD\_LOCK bit will be set HIGH whenever the flywheel has achieved full synchronization. The INT\_PROG bit will be set LOW if the detected video standard is progressive and HIGH if the detected video standard is interlaced.

The VD\_STD[4:0], STD\_LOCK and INT\_PROG bits of the VIDEO\_STANDARD register will default to zero after device reset. These bits will also default to zero if the device loses lock to the input data stream, (LOCKED = LOW), or if the SMPTE\_BYPASS pin is asserted LOW.

**Table 4-7: Host Interface Description for Video Standard and Data Format Register**

Register Name	Bit	Name	Description	R/W	Default
VIDEO_STANDARD Address: 004h	15	–	Not Used.	–	–
	14-10	VD_STD[4:0]	Video Data Standard (see <a href="#">Table 4-9</a> ).	R	0
	9	INT_PROG	Interlace/Progressive: Set LOW if detected video standard is PROGRESSIVE and is set HIGH if it is INTERLACED.	R	0
	8	STD_LOCK	Standard Lock: Set HIGH when flywheel has achieved full synchronization.	R	0
	7-4	CDATA_FORMAT[3:0]	Chroma Data Format. Set HIGH in SD mode. Indicates chroma data format in HD mode (see <a href="#">Table 4-10</a> ).	R	F <sub>h</sub>
	3-0	YDATA_FORMAT[3:0]	Luma Data Format. Indicates Luma data format in HD mode and data format in SD mode (see <a href="#">Table 4-10</a> ).	R	F <sub>h</sub>

**Table 4-8: Host Interface Description for Raster Structure Registers**

Register Name	Bit	Name	Description	R/W	Default
RASTER_STRUCTURE1 Address: 00Eh	15-12	–	Not Used.	–	–
	11-0	RASTER_STRUCTURE1[11:0]	Words Per Active Line.	R	0
RASTER_STRUCTURE2 Address: 00Fh	15-12	–	Not Used.	–	–
	11-0	RASTER_STRUCTURE2[11:0]	Words Per Total Line.	R	0
RASTER_STRUCTURE3 Address: 010h	15-11	–	Not Used.	–	–
	10-0	RASTER_STRUCTURE3[10:0]	Total Lines Per Frame.	R	0
RASTER_STRUCTURE4 Address: 011h	15-11	–	Not Used.	–	–
	10-0	RASTER_STRUCTURE4[10:0]	Active Lines Per Field.	R	0



Table 4-9: Supported Video Standards

VD_STD[4:0]	SMPTE Standard	Video Format	Length of HANC	Length of Active Video	Total Samples	SMPTE352M Lines
00h	296M (HD)	1280x720/60 (1:1)	358	1280	1650	13
01h	296M (HD)	1280x720/60 (1:1) - EM	198	1440	1650	13
02h	296M (HD)	1280x720/30 (1:1)	2008	1280	3300	13
03h	296M (HD)	1280x720/30 (1:1) - EM	408	2880	3300	13
04h	296M (HD)	1280x720/50 (1:1)	688	1280	1980	13
05h	296M (HD)	1280x720/50 (1:1) - EM	240	1728	1980	13
06h	296M (HD)	1280x720/25 (1:1)	2668	1280	3960	13
07h	296M (HD)	1280x720/25 (1:1) - EM	492	3456	3960	13
08h	296M (HD)	1280x720/24 (1:1)	2833	1280	4125	13
09h	296M (HD)	1280x720/24 (1:1) - EM	513	3600	4125	13
0Ah	274M (HD)	1920x1080/60 (2:1) or 1920x1080/30 (PsF)	268	1920	2200	10, 572
0Bh	274M (HD)	1920x1080/30 (1:1)	268	1920	2200	18
0Ch	274M (HD)	1920x1080/50 (2:1) or 1920x1080/25 (PsF)	708	1920	2640	10, 572
0Dh	274M (HD)	1920x1080/25 (1:1)	708	1920	2640	18
0Eh	274M (HD)	1920x1080/25 (1:1) - EM	324	2304	2640	18
0Fh	274M (HD)	1920x1080/25 (PsF) - EM	324	2304	2640	10, 572
10h	274M (HD)	1920x1080/24 (1:1)	818	1920	2750	18
11h	274M (HD)	1920x1080/24 (PsF)	818	1920	2750	10, 572
12h	274M (HD)	1920x1080/24 (1:1) - EM	338	2400	2750	18
13h	274M (HD)	1920x1080/24 (PsF) - EM	338	2400	2750	10, 572
14h	295M (HD)	1920x1080/50 (2:1)	444	1920	2376	10, 572
15h	260M (HD)	1920x1035/60 (2:1)	268	1920	2200	10, 572
16h	125M (SD)	1440x487/60 (2:1) (Or dual link progressive)	268	1440	1716	13, 276
17h	125M (SD)	1440x507/60 (2:1)	268	1440	1716	13, 276
19h	125M (SD)	525-line 487 generic	–	–	1716	13, 276
1Bh	125M (SD)	525-line 507 generic	–	–	1716	13, 276

**Table 4-9: Supported Video Standards (Continued)**

VD_STD[4:0]	SMPTE Standard	Video Format	Length of HANC	Length of Active Video	Total Samples	SMPTE352M Lines
18h	ITU-R BT.656 (SD)	1440x576/50 (2:1) (Or dual link progressive)	280	1440	1728	9, 322
1Ah	ITU-R BT.656 (SD)	625-line generic (EM)	–	–	1728	9, 322
1Dh	Unknown HD	–	–	–	–	–
1Eh	Unknown SD	–	–	–	–	–
1Ch, 1Fh	Reserved	–	–	–	–	–

**4.10.4.2 Data Format Indication**

The luma and chroma data format codes will be reported in the YDATA\_FORMAT[3:0] and CDATA\_FORMAT[3:0] bits of the VIDEO\_STANDARD register when the device is operating in HD mode, (SD/HD = LOW).

In SD or DVB-ASI mode, the data format code will only appear in the YDATA\_FORMAT[3:0] bits. The CDATA\_FORMAT[3:0] bits will be set to 'F<sub>h</sub>'. These codes represent the data formats listed in [Table 4-10](#).

The YDATA\_FORMAT[3:0] and CDATA\_FORMAT[3:0] bits of the VIDEO\_STANDARD register will default to 'F<sub>h</sub>' after device reset. These bits will also default to 'F<sub>h</sub>' if the device loses lock to the input data stream, (LOCKED = LOW), or if Data-Through mode is enabled, (see [Section 4.9](#)).

**Table 4-10: Data Format Codes**

YDATA_FORMAT[3:0] or CDATA_FORMAT[3:0]	Data Format	Applicable Standards
0h	SDTI DVCPRO - No ECC	SMPTE 321M
1h	SDTI DVCPRO - ECC	SMPTE 321M
2h	SDTI DVCAM	SMPTE 322M
3h	SDTI CP	SMPTE 326M
4h	Other SDTI fixed block size	–
5h	Other SDTI variable block size	–
6h	SDI	–
7h	DVB-ASI	–
8h	TDM data	SMPTE 346M
9h ~ Eh	Reserved	–
Fh	Unknown data format	–

### 4.10.5 Error Detection and Indication

The GS1559 contains a number of error detection functions to enhance operation of the device when operating in SMPTE mode. These functions, (except lock error detection), will not be available in either DVB-ASI or Data-Through operating modes. See [Section 4.8](#) and [Section 4.9](#).

The device maintains an error status register at address 001<sub>h</sub> called ERROR\_STATUS ([Table 4-11](#)). Each type of error has a specific flag or bit in this register which is set HIGH whenever that error is detected.

The ERROR\_STATUS register will be cleared at the start of each video field or when read by the host interface, whichever condition occurs first.

All bits of the ERROR\_STATUS register except the LOCK\_ERR bit will also be cleared if a change in the video standard is detected, or under the following conditions:

- $\overline{\text{RESET\_TRST}}$  is held LOW
- LOCKED is asserted LOW
- $\overline{\text{SMPTE\_BYPASS}}$  is asserted LOW in slave mode

In addition to the ERROR\_STATUS register, a register called ERROR\_MASK ([Table 4-12](#)) is included which allows the host interface to select the specific error conditions that will be detected. There is one bit in the ERROR\_MASK register for each type of error represented in the ERROR\_STATUS register.

The bits of the ERROR\_MASK register will default to '0' after device reset, thus enabling all error types to be detected. The host interface may disable individual error detection by setting the corresponding bit HIGH in this register.

Error conditions are also indicated to the application layer via the status signal pin  $\overline{\text{DATA\_ERROR}}$ . This output pin is a logical 'OR'ing of each error status flag stored in the ERROR\_STATUS register.  $\overline{\text{DATA\_ERROR}}$  is normally HIGH, but will be set LOW by the device when an error condition that has not been masked is detected.

**Table 4-11: Host Interface Description for Error Status Register**

Register Name	Bit	Name	Description	R/W	Default
ERROR_STATUS Address: 001h	15-11	–	Not Used.	–	–
	10	VD_STD_ERR	Video Standard Error Flag. Set HIGH when a mismatch between the received SMPTE352M packets and the calculated video standard occurs.	R	0
	9	FF_CRC_ERR	Full Field CRC Error Flag. Set HIGH in SD mode when a Full Field (FF) CRC mismatch has been detected in Field 1 or 2.	R	0
	8	AP_CRC_ERR	Active Picture CRC Error Flag. Set HIGH in SD mode when an Active Picture (AP) CRC mismatch has been detected in Field 1 or 2.	R	0
	7	LOCK_ERR	Lock Error Flag. Set HIGH whenever the LOCK pin is LOW (indicating the device not correctly locked).	R	0
	6	CCS_ERR	Chroma Checksum Error Flag. Set HIGH when ancillary data packet checksum error has been detected in the C channel.	R	0
	5	YCS_ERR	Luma Checksum Error Flag. Set HIGH when ancillary data packet checksum error has been detected in the Y channel.	R	0
	4	CCRC_ERR	Chroma CRC Error Flag. Set HIGH in HD mode when a mismatch occurs between the calculated and received CRC values in the C channel.	R	0
	3	YCRC_ERR	Luma CRC Error Flag. Set HIGH in HD mode when a mismatch occurs between the calculated and received CRC values in the Y channel.	R	0
	2	LNUM_ERR	Line Number Error Flag. Set HIGH in HD mode when a mismatch occurs between the calculated and received line numbers.	R	0
1	SAV_ERR	Start of Active Video Error Flag. Set HIGH when TRS errors are detected in either 8-bit or 10-bit TRS words. In HD mode only Y channel TRS codes will be checked. FW_EN/DIS must be set HIGH.	R	0	
0	EAV_ERR	End of Active Video Error Flag. Set HIGH when TRS errors are detected in either 8-bit or 10-bit TRS words. In HD mode only Y channel TRS codes will be checked. FW_EN/DIS must be set HIGH.	R	0	

**Table 4-12: Host Interface Description for Error Mask Register**

Register Name	Bit	Name	Description	R/W	Default
ERROR_MASK Address: 01Ah	15-11	–	Not Used.	–	–
	10	VD_STD_ERR_MASK	Video Standard Error Flag Mask bit.	R/W	0
	9	FF_CRC_ERR_MASK	Full Field CRC Error Flag Mask bit.	R/W	0
	8	AP_CRC_ERR_MASK	Active Picture CRC Error Flag Mask bit.	R/W	0
	7	LOCK_ERR_MASK	Lock Error Flag Mask bit.	R/W	0
	6	CCS_ERR_MASK	Chroma Checksum Error Flag Mask bit.	R/W	0
	5	YCS_ERR_MASK	Luma Checksum Error Flag Mask bit.	R/W	0
	4	CCRC_ERR_MASK	Chroma CRC Error Flag Mask bit.	R/W	0
	3	YCRC_ERR_MASK	Luma CRC Error Flag Mask bit.	R/W	0
	2	LNUM_ERR_MASK	Line Number Error Flag Mask bit.	R/W	0
	1	SAV_ERR_MASK	Start of Active Video Error Flag Mask bit.	R/W	0
	0	EAV_ERR_MASK	End of Active Video Error Flag Mask bit.	R/W	0

#### 4.10.5.1 Video Standard Error Detection

If a mismatch between the received SMPTE 352M packets and the calculated video standard occurs, the GS1559 will indicate a video standard error by setting the VD\_STD\_ERR bit of the ERROR\_STATUS register HIGH.

#### 4.10.5.2 EDH CRC Error Detection

The GS1559 calculates Full Field (FF) and Active Picture (AP) CRC words according to SMPTE RP165 in support of Error Detection and Handling packets in SD signals.

These calculated CRC values are compared with the received CRC values. If a mismatch is detected, the error is flagged in the AP\_CRC\_ERR and/or FF\_CRC\_ERR bits of the ERROR\_STATUS register. These two flags are shared between fields 1 and 2.

The AP\_CRC\_ERR bit will be set HIGH when an active picture CRC mismatch has been detected in field 1 or 2. The FF\_CRC\_ERR bit will be set HIGH when a full field CRC mismatch has been detected in field 1 or 2.

EDH CRC errors will only be indicated when the device is operating in SD mode ( $\overline{\text{SD/HD}} = \text{HIGH}$ ), and when the device has correctly received EDH packets.

SMPTE RP165 specifies the calculation ranges and scope of EDH data for standard 525 and 625 component digital interfaces. The GS1559 will utilize these standard ranges by default.

If the received video format does not correspond to 525 or 625 digital component video standards as determined by the flywheel pixel and line counters, then one of two schemes for determining the EDH calculation ranges will be employed:

1. Ranges will be based on the line and pixel ranges programmed by the host interface; or
2. In the absence of user-programmed calculation ranges, ranges will be determined from the received TRS timing information.

The registers available to the host interface for programming EDH calculation ranges include active picture and full field line start and end positions for both fields. [Table 4-13](#) shows the relevant registers, which default to '0' after device reset.

If any or all of these register values are zero, then the EDH CRC calculation ranges will be determined from the flywheel generated H signal. The first active and full field pixel will always be the first pixel after the SAV TRS code word. The last active and full field pixel will always be the last pixel before the start of the EAV TRS code words.

**Table 4-13: Host Interface Description for EDH Calculation Range Registers**

Register Name	Bit	Name	Description	R/W	Default
AP_LINE_START_F0 Address: 012h	15-10	–	Not Used.	–	–
	9-0	AP_LINE_START_F0[9:0]	Field 0 Active Picture start line data used to set EDH calculation range outside of SMPTE RP 165 values.	R/W	0
AP_LINE_END_F0 Address: 013h	15-10	–	Not Used.	–	–
	9-0	AP_LINE_END_F0[9:0]	Field 0 Active Picture end line data used to set EDH calculation range outside of SMPTE RP 165 values.	R/W	0
AP_LINE_START_F1 Address: 014h	15-10	–	Not Used.	–	–
	9-0	AP_LINE_START_F1[9:0]	Field 1 Active Picture end line data used to set EDH calculation range outside of SMPTE RP 165 values.	R/W	0
AP_LINE_END_F1 Address: 015h	15-10	–	Not Used.	–	–
	9-0	AP_LINE_END_F1[9:0]	Field 1 Active Picture end line data used to set EDH calculation range outside of SMPTE RP 165 values.	R/W	0

**Table 4-13: Host Interface Description for EDH Calculation Range Registers (Continued)**

Register Name	Bit	Name	Description	R/W	Default
FF_LINE_START_F0 Address: 016h	15-10	–	Not Used.	–	–
	9-0	FF_LINE_START_F0[9:0]	Field 0 Full Field start line data used to set EDH calculation range outside of SMPTE RP 165 values.	R/W	0
FF_LINE_END_F0 Address: 017h	15-10	–	Not Used.	–	–
	9-0	FF_LINE_END_F0[9:0]	Field 0 Full Field start line data used to set EDH calculation range outside of SMPTE RP 165 values.	R/W	0
FF_LINE_START_F1 Address: 018h	15-10	–	Not Used.	–	–
	9-0	FF_LINE_START_F1[9:0]	Field 1 Full Field start line data used to set EDH calculation range outside of SMPTE RP 165 values.	R/W	0
FF_LINE_END_F1 Address: 019h	15-10	–	Not Used.	–	–
	9-0	FF_LINE_END_F1[9:0]	Field 1 Full Field end line data used to set EDH calculation range outside of SMPTE RP 165 values.	R/W	0

#### 4.10.5.3 Lock Error Detection

The LOCKED pin of the GS1559 indicates the lock status of the reclocker and lock detect blocks of the device. Only when the LOCKED pin is asserted HIGH has the device correctly locked to the received data stream, (see [Section 4.6.1](#)).

The GS1559 will also indicate lock error to the host interface when LOCKED = LOW by setting the LOCK\_ERR bit in the ERROR\_STATUS register HIGH.

#### 4.10.5.4 Ancillary Data Checksum Error Detection

The GS1559 will calculate checksums for all received ancillary data and compare the calculated values to the received checksum words. If a mismatch is detected, the error is flagged in the CCS\_ERR and/or YCS\_ERR bits of the ERROR\_STATUS register.

When operating in HD mode, ( $\overline{SD/HD} = \text{LOW}$ ), the device will make comparisons on both the Y and C channels separately. If an error condition in the Y channel is detected, the YCS\_ERR bit will be set HIGH. If an error condition in the C channel is detected, the CCS\_ERR bit will be set HIGH.

When operating in SD mode, ( $\overline{SD/HD} = \text{HIGH}$ ), only the YCS\_ERR bit will be set HIGH when checksum errors are detected.

Although the GS1559 will calculate and compare checksum values for all ancillary data types by default, the host interface may program the device to check only certain types of ancillary data checksums.

This is accomplished via the ANC\_TYPE register as described in [Section 4.10.2.1](#).

#### 4.10.5.5 Line Based CRC Error Detection

The GS1559 will calculate line based CRC words for HD video signals for both the Y and C data channels. These calculated CRC values are compared with the received CRC values and any mismatch is flagged in the YCRC\_ERR and/or CCRC\_ERR bits of the ERROR\_STATUS register.

Line based CRC error flags will only be generated when the device is operating in HD mode, ( $\overline{SD/HD}$  = LOW).

If a CRC error is detected in the Y channel, the YCRC\_ERR bit in the error status register will be set HIGH. If a CRC error is detected in the C channel, the CCRC\_ERR bit in the error status register is set HIGH. Y and C CRC errors will also be generated if CRC values are not received.

#### 4.10.5.6 HD Line Number Error Detection

When operating in HD mode, the GS1559 will calculate line numbers based on the timing generated by the internal flywheel. These calculated line numbers are compared with the received line numbers for the Y channel data and any mismatch is flagged in the LNUM\_ERR bit of the ERROR\_STATUS.

Line number errors will also be generated if line number values are not received.

#### 4.10.5.7 TRS Error Detection

TRS errors flags are generated by the GS1559 when:

1. The received TRS timing does not correspond to the internal flywheel timing;  
or
2. The received TRS hamming codes are incorrect.

Both 8-bit and 10-bit SAV and EAV TRS words are checked for timing and data integrity errors. These are flagged via the SAV\_ERR and/or EAV\_ERR bits of the ERROR\_STATUS register.

Timing-based TRS errors will only be generated if the  $\overline{FW\_EN/DIS}$  pin is set HIGH.

NOTE: In HD mode, ( $\overline{SD/HD}$  = LOW), only the Y channel TRS codes will be checked for errors.

### 4.10.6 Error Correction and Insertion

In addition to signal error detection and indication, the GS1559 may also correct certain types of errors by inserting corrected code words, checksums and CRC values into the data stream. These features are only available in SMPTE mode and IOPROC\_EN/ $\overline{DIS}$  must be set HIGH. Individual correction features may be enabled or disabled via the IOPROC\_DISABLE register (Table 4-14).

All of the IOPROC\_DISABLE register bits default to '0' after device reset, enabling all of the processing features. To disable any individual error correction feature, the host interface must set the corresponding bit HIGH in the IOPROC\_DISABLE register.



**Table 4-14: Host Interface Description for Internal Processing Disable Register**

Register Name	Bit	Name	Description	R/W	Default
IOPROC_DISABLE Address: 000h	15-9	–	Not Used.	–	–
	8	H_CONFIG	Horizontal sync timing output configuration. Set LOW for active line blanking timing. Set HIGH for H blanking based on the H bit setting of the TRS words. See <a href="#">Figure 4-2</a> .		0
	7-6	–	Not Used.	–	–
	5	ILLEGAL_REMAP	Illegal Code re-mapping. Correction of illegal code words within the active picture. Set HIGH to disable. The IOPROC_EN/DIS pin must be set HIGH.	R/W	0
	4	EDH_CRC_INS	Error Detection & Handling (EDH) Cyclical Redundancy Check (CRC) error correction insertion. In SD mode set HIGH to disable. The IOPROC_EN/DIS pin must be set HIGH.	R/W	0
	3	ANC_CSUM_INS	Ancillary Data Check-sum insertion. Set HIGH to disable. The IOPROC_EN/DIS pin must be set HIGH.	R/W	0
	2	CRC_INS	Y and C line based CRC insertion. In HD mode, inserts line based CRC words in both the Y and C channels. Set HIGH to disable. The IOPROC_EN/DIS pin must be set HIGH.	R/W	0
	1	LNUM_INS	Y and C line number insertion. In HD mode set HIGH to disable. The IOPROC_EN/DIS pin must be set HIGH.	R/W	0
	0	TRS_INS	Timing Reference Signal Insertion. Set HIGH to disable. The IOPROC_EN/DIS pin must be set HIGH.	R/W	0

#### 4.10.6.1 Illegal Code Remapping

If the ILLEGAL\_REMAP bit of the IOPROC\_DISABLE register is set LOW, the GS1559 will remap all codes within the active picture between the values of 3FCh and 3FFh to 3FBh. All codes within the active picture area between the values of 000h and 003h will be re-mapped to 004h.

In addition, 8-bit TRS and ancillary data preambles will be remapped to 10-bit values if this feature is enabled.

#### 4.10.6.2 EDH CRC Error Correction

The GS1559 will generate and insert active picture and full field CRC words into the EDH data packets received by the device. This feature is only available in SD mode and is enabled by setting the EDH\_CRC\_INS bit of the IOPROC\_DISABLE register LOW.

EDH CRC calculation ranges are described in [Section 4.10.5.2](#).

NOTE: Although the GS1559 will modify and insert EDH CRC words and EDH packet checksums, EDH error flags will not be updated by the device.

#### 4.10.6.3 Ancillary Data Checksum Error Correction

When ancillary data checksum error correction and insertion is enabled, the GS1559 will generate and insert ancillary data checksums for all ancillary data words by default. Where user specified ancillary data has been programmed into the device ([Section 4.10.2.1](#)), only the checksums for the programmed ancillary data types will be corrected.

This feature is enabled when the ANC\_CSUM\_INS bit of the IOPROC\_DISABLE register is set LOW.

#### 4.10.6.4 Line Based CRC Correction

The GS1559 will generate and insert line based CRC words into both the Y and C channels of the data stream. This feature is only available in HD mode and is enabled by setting the CRC\_INS bit of the IOPROC\_DISABLE register LOW.

#### 4.10.6.5 HD Line Number Error Correction

In HD mode, the GS1559 will calculate and insert line numbers into the Y and C channels of the output data stream.

Line number generation is in accordance with the relevant HD video standard as determined by the device, (see [Section 4.10.4](#)).

This feature is enabled when  $\overline{SD/HD} = \text{LOW}$ , and the LNUM\_INS bit of the IOPROC\_DISABLE register is set LOW.

#### 4.10.6.6 TRS Error Correction

When TRS error correction and insertion is enabled, the GS1559 will generate and insert 10-bit TRS code words as required.

TRS word generation will be performed in accordance with the timing parameters generated by the flywheel to provide an element of noise immunity. As a result, TRS correction will only take place if the flywheel is enabled, ( $\overline{FW\_EN/DIS} = \text{HIGH}$ ).

In addition, the TRS\_INS bit of the IOPROC\_DISABLE register must be set LOW.

### 4.10.7 EDH Flag Detection

As described in [Section 4.10.5.2](#), the GS1559 can detect EDH packets in the received data stream. The EDH flags for ancillary data, active picture and full field areas are extracted from the detected EDH packets and placed in the EDH\_FLAG register of the device ([Table 4-15](#)).

One set of flags is provided for both fields 1 and 2. Field 1 flag data will be overwritten by field 2 flag data.

The EDH\_FLAG register may be read by the host interface at any time during the received frame except on the lines defined in SMPTE RP165 where these flags are updated.

NOTE 1: By programming the ANC\_TYPE1 register (005h) with the DID word for EDH ancillary packets, the application layer may detect a high-to-low transition on either the YANC or CANC output pin of the GS1559 to determine (a) when EDH packets have been received by the device, and (b) when the EDH\_FLAG register can be read by the host interface. See [Section 4.10.2](#) for more information on ancillary data detection and indication.

NOTE 2: The bits of the EDH\_FLAG register are sticky and will not be cleared by a read operation. If the GS1559 is decoding a source containing EDH packets, where EDH flags may be set, and the source is replaced by one without EDH packets, the EDH\_FLAG register will not be cleared.

NOTE 3: The GS1559 will detect EDH flags, but will not update the flags if an EDH CRC error is detected. Genum's GS1532 Multi-Rate Serializer allows the host to individually set EDH flags.

**Table 4-15: Host Interface Description for EDH Flag Register**

Register Name	Bit	Name	Description	R/W	Default
EDH_FLAG Address: 003h	15	–	Not Used.	–	–
	14	ANC-UES out	Ancillary Unknown Error Status Flag.	R	0
	13	ANC-IDA out	Ancillary Internal device error Detected Already Flag.	R	0
	12	ANC-IDH out	Ancillary Internal device error Detected Here Flag.	R	0
	11	ANC-EDA out	Ancillary Error Detected Already Flag.	R	0
	10	ANC-EDH out	Ancillary Error Detected Here Flag.	R	0
	9	FF-UES out	Full Field Unknown Error Status Flag.	R	0
	8	FF-IDA out	Full Field Internal device error Detected Already Flag.	R	0
	7	FF-IDH out	Full Field Internal device error Detected Here Flag.	R	0
	6	FF-EDA out	Full Field Error Detected Already Flag.	R	0
	5	FF-EDH out	Full Field Error Detected Here Flag.	R	0
	4	AP-UES out	Active Picture Unknown Error Status Flag.	R	0
	3	AP-IDA out	Active Picture Internal device error Detected Already Flag.	R	0
	2	AP-IDH out	Active Picture Internal device error Detected Here Flag.	R	0
	1	AP-EDA out	Active Picture Error Detected Already Flag.	R	0
	0	AP-EDH out	Active Picture Error Detected Here Flag.	R	0

## 4.11 Parallel Data Outputs

Data outputs leave the device on the rising edge of PCLK as shown in [Figure 4-7](#) and [Figure 4-8](#).

The data may be scrambled or unscrambled, framed or unframed, and may be presented in 10-bit or 20-bit format. The output data bus width is controlled independently from the internal data bus width by the 20bit/10bit input pin.

Likewise, the output data format is defined by the setting of the external  $\overline{\text{SD/HD}}$ ,  $\overline{\text{SMPTE\_BYPASS}}$  and  $\overline{\text{DVB\_ASI}}$  pins. Recall that in slave mode, these pins are set by the application layer as inputs to the device. In master mode, however, the GS1559 sets these pins as output status signals.

### 4.11.1 Parallel Data Bus Buffers

The parallel data outputs of the GS1559 are driven by high-impedance buffers which support both LVTTTL and LVCMOS levels. These buffers use a separate power supply of +3.3V DC supplied via the IO\_VDD and IO\_GND pins.

All output buffers, including the PCLK output, may be driven to a high-impedance state if the  $\overline{\text{RESET\_TRST}}$  signal is asserted LOW.

Note that the timing characteristics of the parallel data output buffers are optimized for 10-bit HD operation. As shown in Figure 4-7, the output data hold time for HD is 1.5ns.

Due to this optimization, however, the output data hold time for SD data is so small that the rising edge of the PCLK is nearly incident with the data transition. To improve output hold time at SD rates, the PCLK output is inverted in SD mode, (SD/HD = HIGH). This is shown in Figure 4-8.

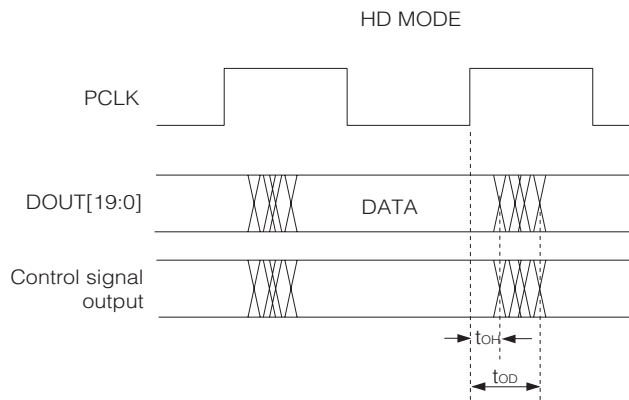

**Figure 4-7: HD PCLK to Data Timing**

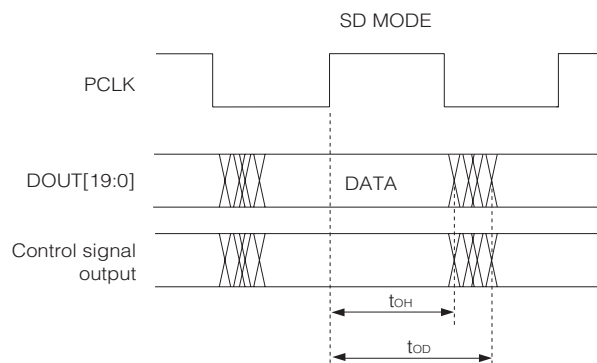

**Figure 4-8: SD PCLK to Data Timing**

### 4.11.2 Parallel Output in SMPTE Mode

When the device is operating in SMPTE mode, (see [Section 4.7](#)), both SD and HD data may be presented to the output bus in either multiplexed or demultiplexed form depending on the setting of the  $\overline{20bit/10bit}$  input pin.

In 20-bit mode, ( $\overline{20bit/10bit} = \text{HIGH}$ ), the output data will be word aligned, demultiplexed luma and chroma data. Luma words will always appear on DOUT[19:10] while chroma words will occupy DOUT[9:0].

In 10-bit mode, ( $\overline{20bit/10bit} = \text{LOW}$ ), the output data will be word aligned, multiplexed luma and chroma data. The data will be presented on DOUT[19:10], and the device will force DOUT[9:0] LOW.

### 4.11.3 Parallel Output in DVB-ASI Mode

When operating in DVB-ASI mode, (see [Section 4.8](#)), the GS1559 automatically configures the output port for 10-bit operation regardless of the setting of the  $\overline{20bit/10bit}$  pin.

The extracted 8-bit data words will be presented on DOUT[17:10] such that DOUT17 = HOUT is the most significant bit of the decoded transport stream data and DOUT10 = AOUT is the least significant bit.

In addition, DOUT19 and DOUT18 will be configured as the DVB-ASI status signals SYNCOUT and WORDERR respectively. See [Section 4.8.2](#) for a description of these DVB-ASI specific output signals.

DOUT[9:0] will be forced LOW when the GS1559 is operating in DVB-ASI mode.

### 4.11.4 Parallel Output in Data-Through Mode

When operating in Data-Through mode, (see [Section 4.9](#)), the GS1559 presents data to the output data bus without performing any decoding, descrambling or word-alignment.

As described in [Section 4.9](#), the data bus outputs will be forced to logic LOW if the device is set to operate in master mode but cannot identify SMPTE TRS ID or DVB-ASI sync words in the input data stream.

### 4.11.5 Parallel Output Clock (PCLK)

The frequency of the PCLK output signal of the GS1559 is determined by the output data format. [Table 4-16](#) below lists the possible output signal formats and their corresponding parallel clock rates. Note that DVB-ASI output will always be in 10-bit format, regardless of the setting of the  $\overline{20bit/10bit}$  pin.

Table 4-16: Parallel Data Output Format

Output Data Format	DOUT [19:10]	DOUT [9:0]	PCLK	Status / Control Signals*			
				20bit/ 10bit	SD/HD	SMPTE_BYPASS	DVB_ASI
<b>SMPTE MODE</b>							
20bit DEMULTIPLEXED SD	LUMA	CHROMA	13.5MHz	HIGH	HIGH	HIGH	LOW
10bit MULTIPLEXED SD	LUMA / CHROMA	FORCED LOW	27MHz	LOW	HIGH	HIGH	LOW
20bit DEMULTIPLEXED HD	LUMA	CHROMA	74.25 or 74.25/ 1.001MHz	HIGH	LOW	HIGH	LOW
10bit MULTIPLEXED HD	LUMA / CHROMA	FORCED LOW	148.5 or 148.5/ 1.001MHz	LOW	LOW	HIGH	LOW
<b>DVB-ASI MODE</b>							
10bit DVB-ASI	DVB-ASI DATA	FORCED LOW	27MHz	HIGH	HIGH	LOW	HIGH
	DVB-ASI DATA	FORCED LOW	27MHz	LOW	HIGH	LOW	HIGH
<b>DATA-THROUGH MODE**</b>							
20bit DEMULTIPLEXED SD	DATA	DATA	13.5MHz	HIGH	HIGH	LOW	LOW
10bit MULTIPLEXED SD	DATA	FORCED LOW	27MHz	LOW	HIGH	LOW	LOW
20bit DEMULTIPLEXED HD	DATA	DATA	74.25 or 74.25/ 1.001MHz	HIGH	LOW	LOW	LOW
10bit MULTIPLEXED HD	DATA	FORCED LOW	148.5 or 148.5/ 1.001MHz	LOW	LOW	LOW	LOW

\*NOTE 1: Recall that SD/HD, SMPTE\_BYPASS, and DVB\_ASI are input control pins in slave mode to be set by the application layer, but are output status signals set by the device in master mode.

\*\*NOTE 2: Data-Through mode is only available in slave mode [Section 4.9](#).

## 4.12 GSPI Host Interface

The GSPI, or Genum Serial Peripheral Interface, is a 4-wire interface provided to allow the host to enable additional features of the device and /or to provide additional status information through configuration registers in the GS1559.

The GSPI comprises a serial data input signal SDIN, serial data output signal SDOUT, an active low chip select  $\overline{CS}$ , and a burst clock SCLK. The burst clock must have a duty cycle between 40% and 60%.

Because these pins are shared with the JTAG interface port, an additional control signal pin JTAG/ $\overline{HOST}$  is provided. When JTAG/ $\overline{HOST}$  is LOW, the GSPI interface is enabled.

When operating in GSPI mode, the SCLK, SDIN, and  $\overline{CS}$  signals are provided by the host interface. The SDOUT pin is a high-impedance output allowing multiple devices to be connected in parallel and selected via the  $\overline{CS}$  input. The interface is illustrated in [Figure 4-9](#).

All read or write access to the GS1559 is initiated and terminated by the host processor. Each access always begins with a 16-bit command word on SDIN indicating the address of the register of interest. This is followed by a 16-bit data word on SDIN in write mode, or a 16-bit data word on SDOUT in read mode.

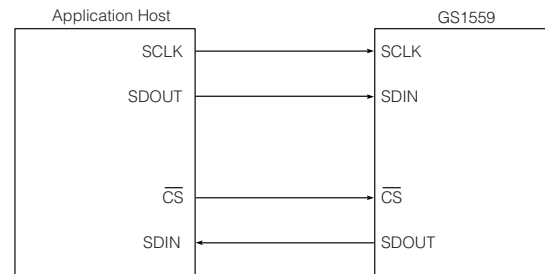

**Figure 4-9: Genum Serial Peripheral Interface (GSPI)**

### 4.12.1 Command Word Description

The command word is transmitted MSB first and contains a read/write bit, nine reserved bits and a 6-bit register address. Set R/W = '1' to read and R/W = '0' to write from the GSPI.

Command words are clocked into the GS1559 on the rising edge of the serial clock SCLK. The appropriate chip select,  $\overline{CS}$ , signal must be asserted low a minimum of 1.5ns ( $t_0$  in [Figure 4-12](#) and [Figure 4-13](#)) before the first clock edge to ensure proper operation.

Each command word must be followed by only one data word to ensure proper operation.





Figure 4-10: Command Word

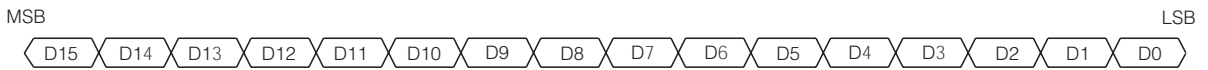

Figure 4-11: Data Word

### 4.12.2 Data Read and Write Timing

Read and write mode timing for the GSPI interface is shown in Figure 4-12 and Figure 4-13 respectively. The maximum SCLK frequency allowed is 6.6MHz.

When writing to the registers via the GSPI, the MSB of the data word may be presented to SDIN immediately following the falling edge of the LSB of the command word. All SDIN data is sampled on the rising edge of SCLK.

When reading from the registers via the GSPI, the MSB of the data word will be available on SDOUT 12ns following the falling edge of the LSB of the command word, and thus may be read by the host on the very next rising edge of the clock. The remaining bits are clocked out by the GS1559 on the negative edges of SCLK.

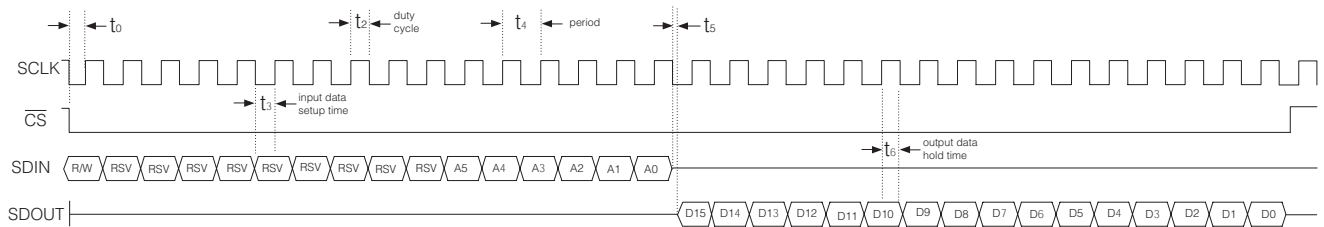

Figure 4-12: GSPI Read Mode Timing

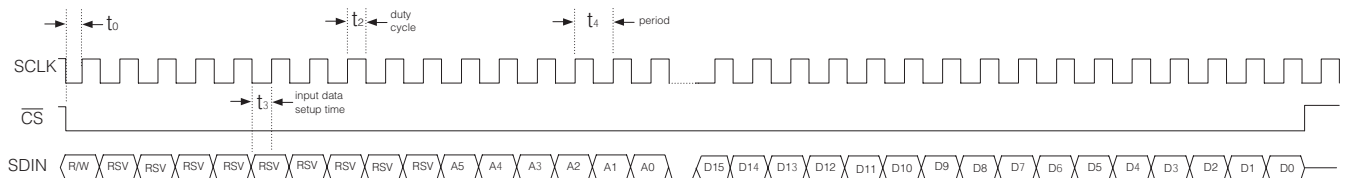

Figure 4-13: GSPI Write Mode Timing

### 4.12.3 Configuration and Status Registers

Table 4-17 summarizes the GS1559's internal status and configuration registers.

All of these registers are available to the host via the GSPI and are all individually addressable.

Where status registers contain less than the full 16 bits of information however, two or more registers may be combined at a single logical address.

**Table 4-17: GS1559 internal registers**

Address	Register Name	See Section
000h	IOPROC_DISABLE	<a href="#">Section 4.10.6</a>
001h	ERROR_STATUS	<a href="#">Section 4.10.5</a>
003h	EDH_FLAG	<a href="#">Section 4.10.7</a>
004h	VIDEO_STANDARD	<a href="#">Section 4.10.4</a>
005h - 009h	ANC_TYPE	<a href="#">Section 4.10.2.1</a>
00Ch - 00Dh	VIDEO_FORMAT	<a href="#">Section 4.10.3</a>
00Eh - 011h	RASTER_STRUCTURE	<a href="#">Section 4.10.4</a>
012h - 019h	EDH_CALC_RANGES	<a href="#">Section 4.10.5.2</a>
01Ah	ERROR_MASK	<a href="#">Section 4.10.5</a>

## 4.13 JTAG

When the JTAG/ $\overline{\text{HOST}}$  input pin of the GS1559 is set HIGH, the host interface port will be configured for JTAG test operation. In this mode, pins H4 to H6 and J6 become TMS, TCK, TDO, and TDI. In addition, the  $\overline{\text{RESET\_TRST}}$  pin will operate as the test reset pin.

Boundary scan testing using the JTAG interface will be enabled in this mode.

There are two methods in which JTAG can be used on the GS1559:

1. As a stand-alone JTAG interface to be used at in-circuit ATE (Automatic Test Equipment) during PCB assembly; or
2. Under control of the host for applications such as system power on self tests.

When the JTAG tests are applied by ATE, care must be taken to disable any other devices driving the digital I/O pins. If the tests are to be applied only at ATE, this can be accomplished with tri-state buffers used in conjunction with the JTAG/ $\overline{\text{HOST}}$  input signal. This is shown in [Figure 4-14](#).

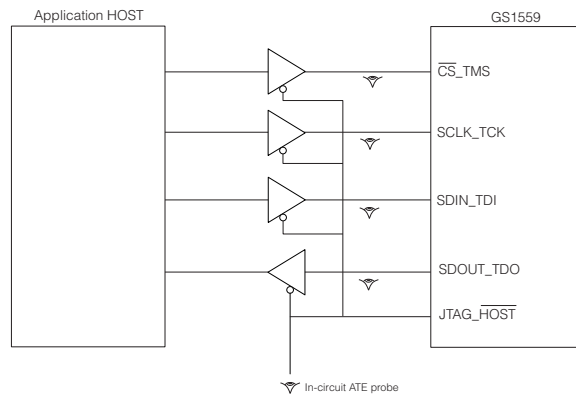

**Figure 4-14: In-Circuit JTAG**

Alternatively, if the test capabilities are to be used in the system, the host may still control the JTAG/HOST input signal, but some means for tri-stating the host must exist in order to use the interface at ATE. This is represented in [Figure 4-15](#).

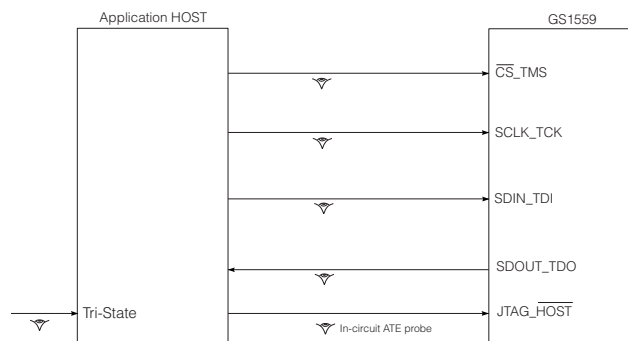

**Figure 4-15: System JTAG**

Please contact your Gennum representative to obtain the BSDL model for the GS1559.

## 4.14 Device Power Up

The GS1559 has a recommended power supply sequence. To ensure correct power up, power the CORE\_VDD pins before the IO\_VDD pins.

Device pins may also be driven prior to power up without causing damage.

To ensure that all internal registers are cleared upon power-up, the application layer must hold the  $\overline{\text{RESET\_TRST}}$  signal LOW for a minimum of 1ms after the core power supply has reached the minimum level specified in [Table 2-3: DC Electrical Characteristics](#). See [Figure 4-16](#).

## 4.15 Device Reset

In order to initialize all internal operating conditions to their default states the application layer must hold the  $\overline{\text{RESET\_TRST}}$  signal LOW for a minimum of  $t_{\text{reset}} = 1\text{ms}$ .

When held in reset, all device outputs will be driven to a high-impedance state.

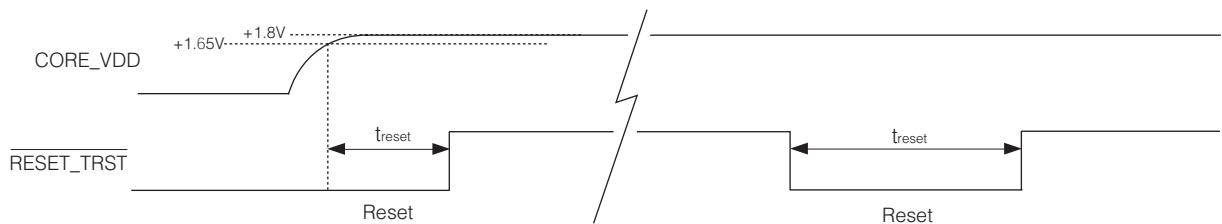

**Figure 4-16: Reset Pulse**

# 5. Application Reference Design

## 5.1 Typical Application Circuit (Part A)

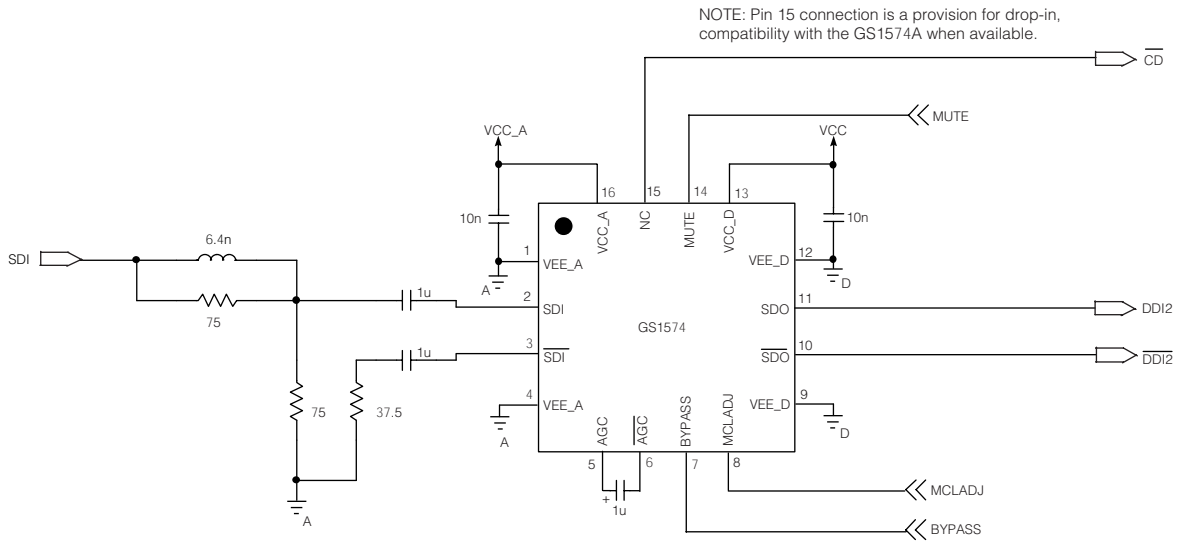

NOTE: All resistors in Ohms, capacitors in Farads, and inductors in Henrys, unless otherwise noted.

### 5.2 Typical Application Circuit (Part B)

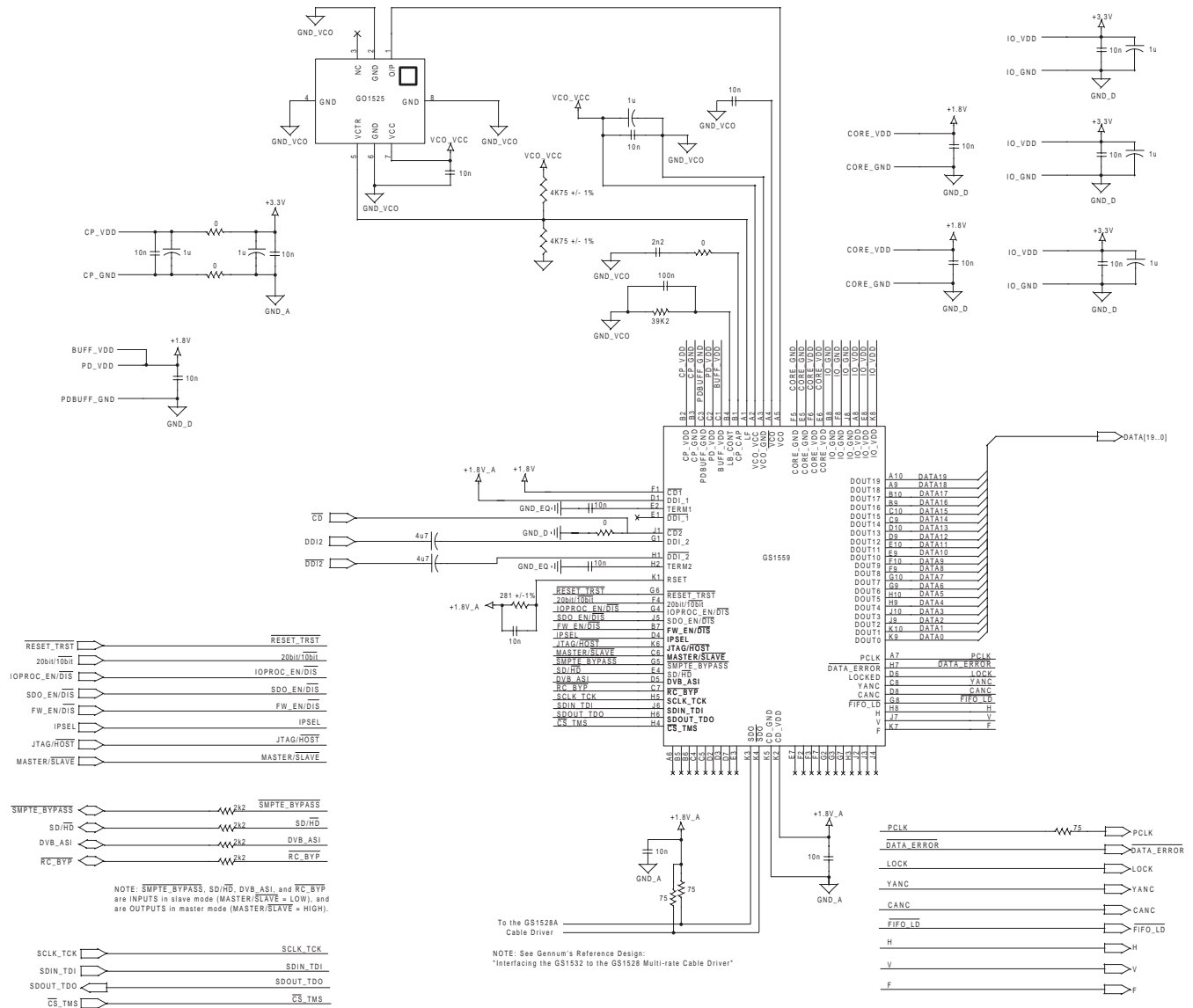

## 6. References & Relevant Standards

SMPTE 125M	Component video signal 4:2:2 – bit parallel interface
SMPTE 260M	1125 / 60 high definition production system – digital representation and bit parallel interface
SMPTE 267M	Bit parallel digital interface – component video signal 4:2:2 16 x 9 aspect ratio
SMPTE 274M	1920 x 1080 scanning analog and parallel digital interfaces for multiple picture rates
SMPTE 291M	Ancillary Data Packet and Space Formatting
SMPTE 292M	Bit-Serial Digital Interface for High-Definition Television Systems
SMPTE 293M	720 x 483 active line at 59.94 Hz progressive scan production – digital representation
SMPTE 296M	1280 x 720 scanning, analog and digital representation and analog interface
SMPTE 352M	Video Payload Identification for Digital Television Interfaces
SMPTE RP165	Error Detection Checkwords and Status Flags for Use in Bit-Serial Digital Interfaces for Television
SMPTE RP168	Definition of Vertical Interval Switching Point for Synchronous Video Switching

# 7. Package & Ordering Information

## 7.1 Package Dimensions

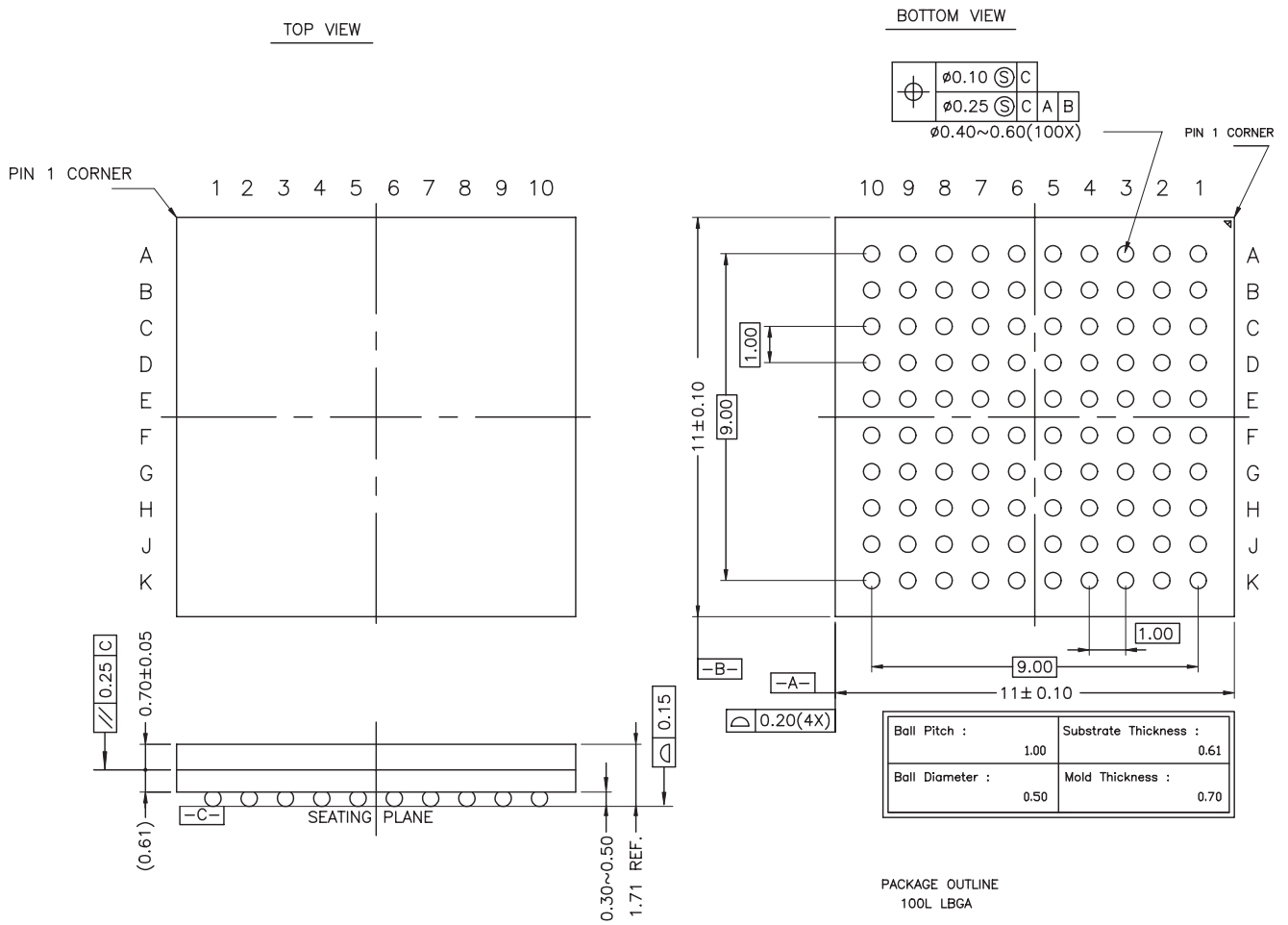

\* THE BALL DIAMETER, BALL PITCH, STAND-OFF & PACKAGE THICKNESS ARE DIFFERENT FROM JEDEC SPEC M0192 (LOW PROFILE BGA FAMILY)



## 7.2 Packaging Data

Parameter	Value
Package Type	11mm x 11mm 100-ball LBGA
Package Drawing Reference	JEDEC M0192
Moisture Saturation Level	3
Junction to Case Thermal Resistance, $\theta_{j-c}$	10.4°C/W
Junction to Air Thermal Resistance, $\theta_{j-a}$ (at zero airflow)	37.1°C/W
Psi	0.4°C/W
Pb-free and Green	Yes

## 7.3 Ordering Information

Part Number	Package	Pb-free Package	Temperature Range
GS1559-CBE2	100-ball BGA	Yes	0°C to 70°C
GS1559-CB	100-ball BGA	No	0°C to 70°C

## 8. Revision History

Version	ECR	Date	Changes and / or Modifications
A	132587	January 2004	New document.
B	133566	June 2004	Modify supply voltage ranges and power dissipation. Modify SDO Section. Modify Figure 3-3. Add note to host interface pins. Add new solder reflow profile. Apply new format.
0	134168	August 2004	Modify Electrical Characteristics based on characterization of device. Update text in Section 2.4. Modify SDO section of recommended application circuit. Update to a Preliminary Data Sheet.
1	134609	November 2004	Update Typical Application Circuit A to remove $\overline{CD}$ pins from the GS1574 circuit.

**CAUTION**

ELECTROSTATIC  
SENSITIVE DEVICES

DO NOT OPEN PACKAGES OR HANDLE  
EXCEPT AT A STATIC-FREE WORKSTATION



**DOCUMENT IDENTIFICATION**

PRELIMINARY DATA SHEET

The product is in a preproduction phase and specifications are subject to change without notice.

**GENNUM CORPORATION**

Mailing Address: P.O. Box 489, Stn. A, Burlington, Ontario, Canada L7R 3Y3

Tel. +1 (905) 632-2996 Fax. +1 (905) 632-5946

Shipping Address: 970 Fraser Drive, Burlington, Ontario, Canada L7L 5P5

**GENNUM JAPAN CORPORATION**

Shinjuku Green Tower Building 27F, 6-14-1, Nishi Shinjuku, Shinjuku-ku,

Tokyo, 160-0023 Japan

Tel. +81 (03) 3349-5501, Fax. +81 (03) 3349-5505

**GENNUM UK LIMITED**

25 Long Garden Walk, Farnham, Surrey, England GU9 7HX

TEL. +44 (0)1252 747 000 FAX +44 (0)1252 726 523

Gennum Corporation assumes no responsibility for the use of any circuits described herein and makes no representations that they are free from patent infringement.

© Copyright January 2004 Gennum Corporation. All rights reserved.

Printed in Canada

[www.gennum.com](http://www.gennum.com)