

CERAFIL[®] (Filters/Traps/Discriminators) for Audio/Visual Equipment

CERAFIL[®]
(Filters/Traps
/Discriminators)
for AUDIO/VISUAL
EQUIPMENT

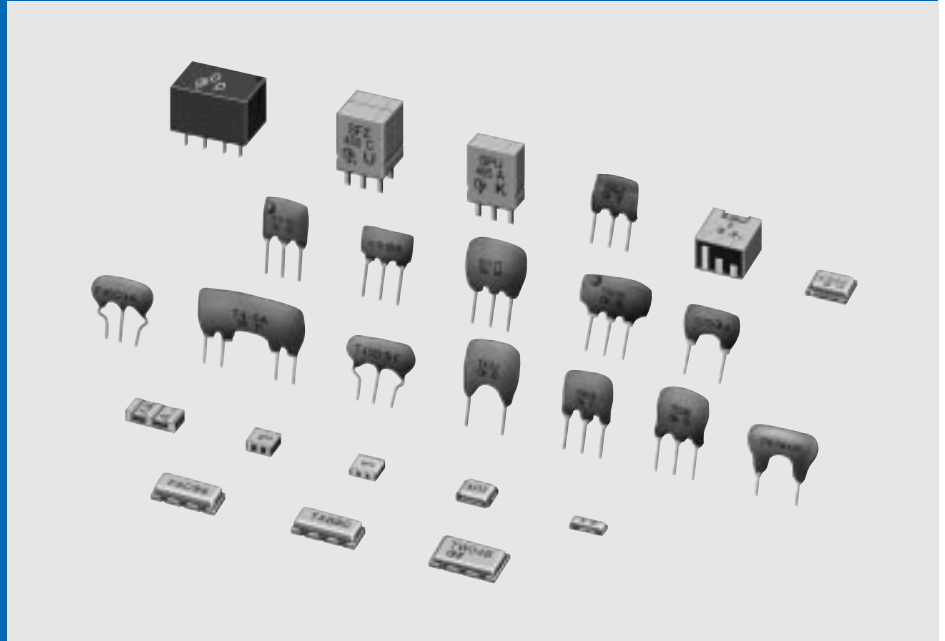

*Innovator
in Electronics*

Murata
Manufacturing Co., Ltd.

Cat.No.P50E

CONTENTS

CERAFIL® and "CERAFIL" in this catalog are the trademarks of Murata Manufacturing Co., Ltd.

Part Numbering	_____	2
1	CERAFIL® 10.7MHz Small Chip Type SF ECS Series	6
2	CERAFIL® 10.7MHz Ultra Thin Chip Type SF ECD Series	9
3	CERAFIL® 10.7MHz Chip Type SF ECV Series	11
4	CERAFIL® 10.7MHz Standard Lead Type	14
5	CERAFIL® 10.7MHz Low Loss Type	17
6	CERAFIL® 10.7MHz Low Profile Type	20
7	CERAFIL® 10.7MHz Low Spurious Response Type	23
8	CERAFIL® 10.7MHz Wide Bandwidth Type	26
9	CERAFIL® 10.7MHz Narrow Bandwidth Type	28
10	CERAFIL® 10.7MHz for FM-IF Tuners	31
11	CERAFIL® 10.7MHz High Selectivity Type SFTLA Series	36
	● CERAFIL® 10.7MHz Related Data on Lead Type	39
12	CERAFIL® 4.5-6.5MHz Chip Type SFSKA Series	40
13	CERAFIL® 4.5-6.5MHz Standard Lead Type SFSRA Series	41
14	CERAFIL® 3.5-6.5MHz Low Profile Type SFSRL Series	46
15	CERAFIL® 3.5-6.5MHz for Chroma Signal SFSRA/L Series	49
16	CERAFIL® 455kHz Chip Type PFWCC Series	51
17	CERAFIL® 455kHz Chip Type SFPCA Series	53
18	CERAFIL® 455kHz SFULA/SFZLA Series	55
19	CERAFIL® 455kHz PFSLA/PFWLA Series	58
20	CERAFIL® 455kHz SFPLA/CFWLA Series	60
21	CERAFIL® 455kHz for AM Stereo Wide Bandwidth Type SFPLA/CFWLA/CFULA Series	62
22	CERAFIL® 455kHz for Search-stop Signal Detection	64
	● CERAFIL® 455kHz SF/PF Series Temperature Characteristics	65
	● CERAFIL® 455kHz SF/PF/BF Series Application Circuit	66
23	Ceramic Trap 4.5-6.5MHz Chip Type TPSKA Series	68
24	Ceramic Trap 4.5-6.5MHz Chip Type Double Traps TPWKA Series	69
25	Ceramic Trap 4.5-6.5MHz Standard Lead Type TPSRA Series	70
26	Ceramic Trap 3.5-6.5MHz Two Lead Type TPSRD Series	73
27	Ceramic Trap 3.5-6.5MHz for 2ch Sound TV in Germany TPSRD Series	76
28	Ceramic Trap 3.5-6.5MHz Double Traps TPWRD Series	77
29	Ceramic Trap 3.5-6.5MHz Triple Traps TPTRD Series	79
30	Ceramic Discriminator 10.7MHz Ultra Thin Chip Type CDSCB Series	80
31	Ceramic Discriminator 10.7MHz Standard Lead Type CDALA Series	84
	● Ceramic Discriminator 10.7MHz Applied IC Reference Table	88
	● Ceramic Discriminator 10.7MHz Applied Circuit	90
32	Ceramic Discriminator 3.5-6.5MHz Wide Bandwidth Type CDSRH Series	92
33	Ceramic Discriminator 3.5-6.5MHz Low Profile Type CDSRL Series	94
Notice (Soldering and Mounting)	_____	96
Notice (Handling)	_____	100
Packaging	_____	107

1
2
3
4
5
6
7
8
9
10
11
12
13
14
15
16
17
18
19
20
21
22
23
24
25
26
27
28
29
30
31
32
33

● Part Numbering

CERAFIL® for FM

(Global Part Number)

SF	E	LA	10M7	FAA0	-B0
①	②	③	④	⑤	⑥

① Product ID

Product ID	
SF	Ceramic Filters

② Oscillation/Numbers of Element

Code	Oscillation/Numbers of Element
E	2 Elements Thickness Expander mode
T	3 Elements Thickness Expander mode
V	2 Elements Thickness Expander mode (2nd Harmonic)
K	2 Elements Thickness Expander mode (3rd Over Tone)

③ Structure/Size

Code	Structure/Size
L□	Lead Type
C□	Chip Type

□ is expressed "A" or subsequent code, which indicates the size.

④ Nominal Center Frequency

Expressed by four-digit alphanumerics. The unit is in hertz (MHz).
Decimal point is expressed by capital letter "M".

CERAFIL® for TV/VCR

(Global Part Number)

SF	S	RA	4M50	CF	00	-B0
①	②	③	④	⑤	⑥	⑦

① Product ID

Product ID	
SF	Ceramic Filters

② Oscillation/Numbers of Element

Code	Oscillation/Numbers of Element
S	2 Elements Thickness Shear mode
T	3 Elements Thickness Expander mode

③ Structure/Size

Code	Structure/Size
R□	Lead Type
K□	Chip Type

□ is expressed "A" or subsequent code, which indicates the size.

④ Nominal Center Frequency

Expressed by four-digit alphanumerics. The unit is in hertz (MHz).
Decimal point is expressed by capital letter "M".

⑤ Product Specification

Code	Product Specification
FAA0	Four-digit alphanumerics express pass-bandwidth, center frequency tolerance, rank, series, others.

⑥ Packaging

Code	Packaging
-B0	Bulk
-R0	Plastic Taping ø180mm
-R1	Plastic Taping ø330mm
-A0	1500pcs./Radial Taping H ₀ =18mm
-A1	1000pcs./Radial Taping H ₀ =18mm

Radial taping is applied to lead type and plastic taping to chip type.
With non-standard products, two-digit alphanumerics indicating "Individual Specification" is added between "⑤ Product Specification" and "⑥ Packaging".

⑤ Product Specification Code (1)

Code	Product Specification Code (1)
AF	Standard Bandwidth Type
BF	Tight Bandwidth Type
CF	Standard Bandwidth Type
DF	Broad Bandwidth Type
EF	Ultra-broad Bandwidth Type

The code **AF** is only applied to **SFT** series.

⑥ Product Specification Code (2)

Code	Product Specification Code (2)
00	Standard Type

⑦ Packaging

Code	Packaging
-B0	Bulk
-A0	Radial Taping H ₀ =18mm
-R1	Plastic Taping ø=330mm

Radial taping is applied to lead type and plastic taping to chip type.
With non-standard products, two-digit alphanumerics indicating "Individual Specification" is added between "⑤ Product Specification Code (1)" and "⑥ Product Specification Code (2)".

CERAFIL® for AM

(Global Part Number) **PF** **W** **LA** **450K** **P2A** **-B0**
① ② ③ ④ ⑤ ⑥

① Product ID

Product ID	
PF	Ceramic Filters
SF	Ceramic Filters
CF	Ceramic Filters

② Oscillation/Numbers of Element

Code	Oscillation/Numbers of Element
S	1 Element Length mode
W	2 Elements Length mode
U	1 Element Area Expansion mode
Z	2 Elements Area Expansion mode
P	4 Elements Area Expansion mode

③ Structure/Size

Code	Structure/Size
L □	Lead Type
C □	Chip Type

□ is "A" or subsequent code, which indicates the size. It varies depending on vibration mode and number of elements.

④ Nominal Center Frequency

Expressed by four-digit alphanumerics. The unit is in hertz (Hz). Capital letter "K" following three figures expresses the unit of "kHz".

CERAFIL® for Search-stop Signal Detection

(Global Part Number) **BF** **U** **LA** **450K** **C** **-B0**
① ② ③ ④ ⑤ ⑥

① Product ID

Product ID	
BF	Resonator

② Oscillation/Numbers of Element

Code	Oscillation/Numbers of Element
U	1 Element Area Expansion mode

③ Structure/Size

Code	Structure/Size
LA	Lead Type Standard

④ Nominal Center Frequency

Code	Nominal Center Frequency
450K	450kHz

⑤ Product Specification

Code	Product Specification
P2A	Standard Type

□□A indicates standard type.

⑥ Packaging

Code	Packaging
-B0	Bulk
-R0	Plastic Taping (ø180mm)
-R1	Plastic Taping (ø330mm)
-A0	Radial Taping H ₀ =18mm
-M0	Magazine Cassette

Radial taping is applied to lead type and plastic taping to chip type. With non-standard products, three-digit alphanumerics indicating "Individual Specification" is added between "⑤ Product Specification" and "⑥ Packaging".

⑤ Product Specification

Code	Product Specification
C □	Bandwidth

With standard type, □ is omitted.

⑥ Packaging

Code	Packaging
-B0	Bulk

Radial taping is applied to lead type and plastic taping to chip type. With non-standard products, "Individual Specification (serial number)" and "Lead Shape (Lead Bend : B)" are added between "⑤ Product Specification" and "⑥ Package Specification Code" upon specification.

Ceramic Traps

(Global Part Number) **TP** **S** **RA** **4M50** **B** **00** **-B0**
① ② ③ ④ ⑤ ⑥ ⑦

① Product ID

Product ID	
TP	Ceramic Traps

② Function

Code	Function
S	Single Traps
T	Triple Traps
W	Double Traps

③ Structure/Size

Code	Structure/Size
R□	Lead Type
K□	Chip Type

□ is expressed "A" or subsequent code, which indicates the size.

④ Nominal Center Frequency

Expressed by four-digit alphanumerics. The unit is in hertz (MHz).
Decimal point is expressed by capital letter "M".

⑤ Product Specification Code (1)

Code	Product Specification (1)
B	Broad-bandwidth Type
C	Low-capacitance Type

⑥ Product Specification Code (2)

Code	Product Specification Code (2)
00	Standard Type

⑦ Packaging

Code	Packaging
-B0	Bulk
-A0	Radial Taping H ₀ =18mm
-R1	Plastic Taping ø=330mm

Radial taping is applied to lead type and plastic taping to chip type.
With non-standard products, three-digit alphanumerics indicating "Individual Specification" is added between "⑥ Product Specification Code (2)" and "⑦ Packaging".

Discriminators for FM

(Global Part Number) **CD** **A** **LA** **10M7** **GA** **001** **-B0**
① ② ③ ④ ⑤ ⑥ ⑦

① Product ID

Product ID	
CD	Discriminators

② Oscillation

Code	Oscillation
A	Thickness Expander mode
S	Thickness Shear mode

③ Structure/Size

Code	Structure/Size
L□	Lead Type
C□	Chip Type

□ is expressed "A" or subsequent code, which indicates the size.

④ Nominal Center Frequency

Expressed by four-digit alphanumerics. The unit is in hertz (MHz).
Decimal point is expressed by capital letter "M".

⑤ Product Specification

Code	Product Specification
GA	Two-digit alphanumerics express type, center frequency, rank, others

⑥ IC

Code	IC
001	Applicable IC Control Code

⑦ Packaging

Code	Packaging
-B0	Bulk
-A0	Radial Taping H ₀ =18mm
-R0	Plastic Taping ø=180mm
-R1	Plastic Taping ø=330mm

Radial taping is applied to lead type and plastic taping to chip type.
With non-standard products, an alphanumerics indicating "Individual Specification" is added between "⑥ IC" and "⑦ Packaging".

Discriminators for TV/VCR

(Global Part Number) **CD** **S** **RH** **4M50** **E** **K** **048** **-A0**
 ① ② ③ ④ ⑤ ⑥ ⑦ ⑧

① Product ID

Product ID	
CD	Discriminators

② Oscillation

Code	Oscillation
S	Thickness Shear mode

③ Structure/Size

Code	Structure/Size
RH	Standard Type
RL	Low-profile

④ Nominal Center Frequency

Expressed by four-digit alphanumerics. The unit is in hertz (MHz).
Decimal point is expressed by capital letter "M".

⑤ Product Specification Code (1)

Code	Product Specification Code (1)
C	Three-terminals
E	Two-terminals

⑥ Product Specification Code (2)

Code	Product Specification Code (2)
K	Specification

⑦ IC

Code	IC
048	Applicable IC control code

⑧ Packaging

Code	Packaging
-B0	Bulk
-A0	Radial Taping H ₀ =18mm

With non-standard products, a letter indicating "Individual Specification" is added between "⑦ IC" and "⑧ Packaging".

CERAFIL® (Filters/Traps/Discriminators) for Audio/Visual Equipment



CERAFIL® 10.7MHz Small Chip Type SF ECS Series

SF ECS10M7 series for FM-receivers are small, high performance and super thin (1.5mm max.) filters. Piezoelectric element is connected in the sandwich shape by ceramics substrate. They have 1.5mm max. thickness and small mounting area. (3.45x3.1mm)

SF ECS series and PFWCC (kHz filter for AM receiver) enable customers to make AM/FM set so thin and small sized.

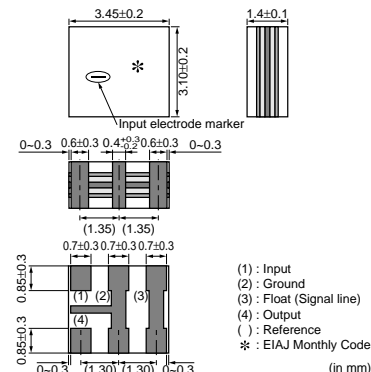
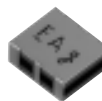

■ Features

1. The filters are mountable by automatic placers.
2. They are slim, at only 1.5mm max. thickness, and have a small mounting area (3.45x3.1mm) enabling flexible PCB design.
3. Various bandwidths are available. Select a suitable type in accordance with the desired selectivity.
4. Operating temperature range :
-20 to +80 (degree C)
Storage temperature range :
-40 to +85 (degree C)

■ Applications

1. Small, thin radios
2. Headphone stereos

Part Number	Center Frequency (fo) (MHz)	Nominal Center Frequency (fn) (MHz)	3dB Bandwidth (kHz)	Attenuation (kHz)	Insertion Loss (dB)	Spurious Attenuation (dB)	Input/Output Impedance (ohm)
SF ECS10M7HA00-R0	10.700 ±30kHz	-	180 ±40kHz	470 max.	4.5 ±2.0dB	30 min.	330
SF ECS10M7GA00-R0	10.700 ±30kHz	-	230 ±50kHz	510 max.	3.5 ±2.0dB	30 min.	330
SF ECS10M7FA00-R0	10.700 ±30kHz	-	280 ±50kHz	590 max.	3.0 ±2.0dB	30 min.	330
SF ECS10M7EA00-R0	10.700 ±30kHz	-	330 ±50kHz	700 max.	3.0 ±2.0dB	30 min.	330
SF ECS10M7DF0021-R0	-	10.700	fn ±200kHz min.	950 max.	3.0 ±2.0dB	20 min.	330

Attenuation Bandwidth : at 20dB loss point Area of Spurious Attenuation : [within 9MHz to 12MHz]
Insertion Loss: at minimum loss point
Center frequency (fo) defined by the center of 3dB bandwidth.
The order quantity should be an integral multiple of the "Minimum Quantity" shown in the package page.

■ Standard Center Frequency Rank Code

CODE	30kHz Step	25kHz Step
D	10.64MHz±30kHz	10.650MHz±25kHz
B	10.67MHz±30kHz	10.675MHz±25kHz
A	10.70MHz±30kHz	10.700MHz±25kHz
C	10.73MHz±30kHz	10.725MHz±25kHz
E	10.76MHz±30kHz	10.750MHz±25kHz
Z	Combination A,B,C,D,E	
M	Combination A,B,C	

Continued on the following page. ↗

Continued from the preceding page.

Standard Land Pattern Dimensions

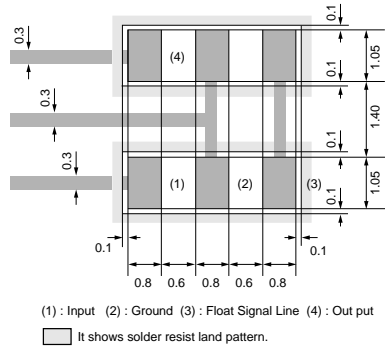

(in mm)

Test Circuit

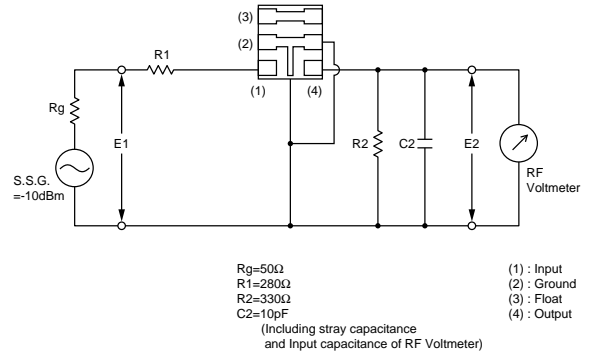

Frequency Characteristics

SFECS10M7HA00-R0

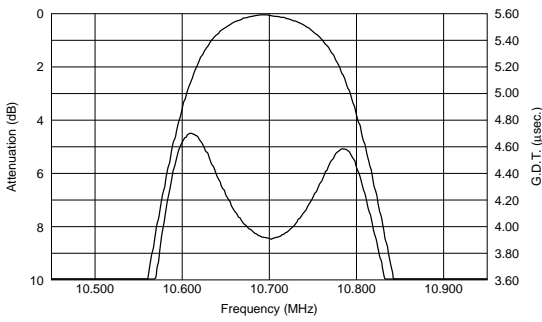

SFECS10M7GA00-R0

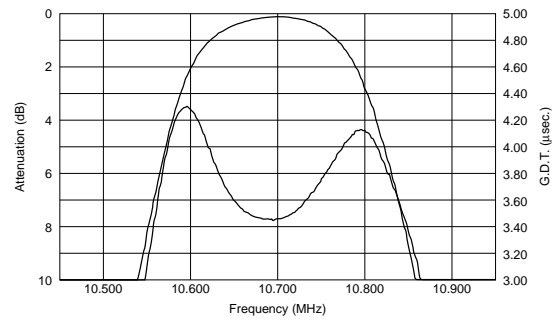

SFECS10M7FA00-R0

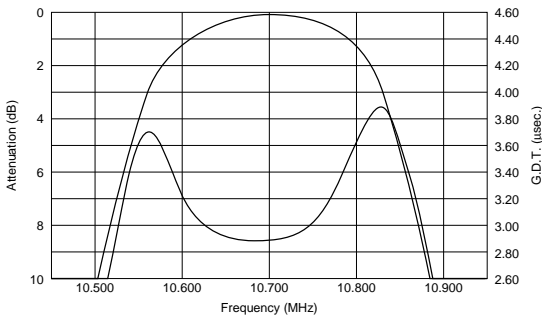

Frequency Characteristics (Spurious)

SFECS10M7HA00-R0

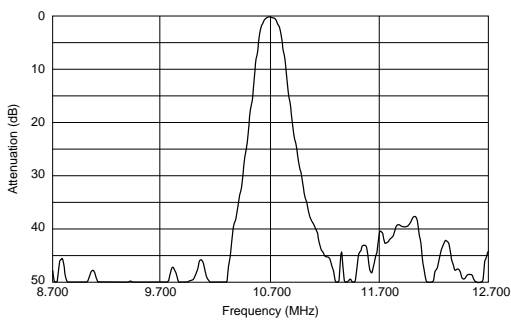

SFECS10M7GA00-R0

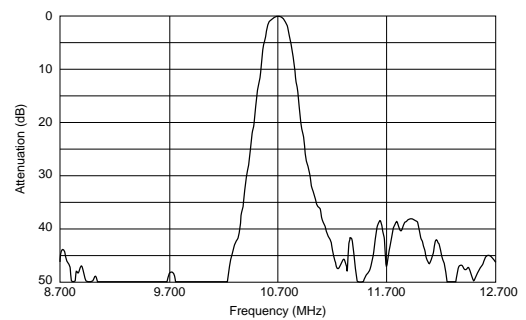

Continued on the following page. ↗

Continued from the preceding page.

1

Frequency Characteristics (Spurious)

SFECS10M7FA00-R0

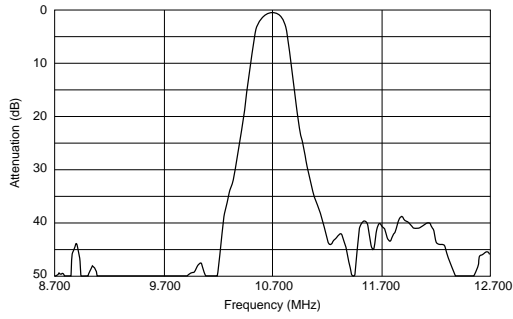

CERAFIL® (Filters/Traps/Discriminators) for Audio/Visual Equipment



CERAFIL® 10.7MHz Ultra Thin Chip Type SFECD Series

SFECD10M7 series for FM-receivers are small, high performance and ultra thin (1.0mm max.) filters. Piezoelectric element is connected in the sandwich shape by very thin ceramics substrate. They have 1.0mm max. thickness and small mounting area. (3.45x3.1mm)

SFECD series enable customers to make RF modules so thin and small sized.

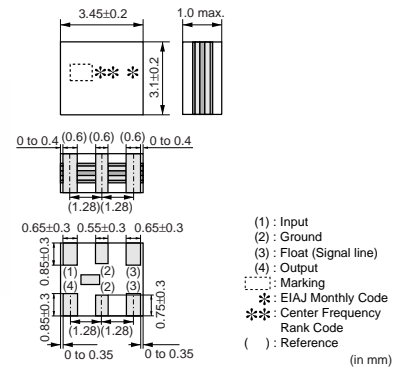

■ Features

1. The filters are mountable by automatic placers.
2. They are slim, at only 1.0mm max. thickness, and have a small mounting area (3.45x3.1mm) enabling flexible PCB design.
3. Operating temperature range :
-20 to +80 (degree C)
Storage temperature range :
-40 to +85 (degree C)

■ Applications

1. Card type radios
2. Card type RKE modules
3. Card type PHS modules

Part Number	Center Frequency (fo) (MHz)	3dB Bandwidth (kHz)	Attenuation (kHz)	Insertion Loss (dB)	Spurious Attenuation (dB)	Input/Output Impedance (ohm)
SFECD10M7FA00-R0	10.700 ±30kHz	280 ±50kHz	590 max.	3.0 ±2.0dB	30 min.	330

Attenuation Bandwidth : at 20dB loss point Area of Spurious Attenuation : [within 9MHz to 12MHz]
Insertion Loss: at minimum loss point
Center frequency (fo) defined by the center of 3dB bandwidth.
The order quantity should be an integral multiple of the "Minimum Quantity" shown in the package page.

■ Standard Center Frequency Rank Code

CODE	30kHz Step	25kHz Step
D	10.64MHz±30kHz	10.650MHz±25kHz
B	10.67MHz±30kHz	10.675MHz±25kHz
A	10.70MHz±30kHz	10.700MHz±25kHz
C	10.73MHz±30kHz	10.725MHz±25kHz
E	10.76MHz±30kHz	10.750MHz±25kHz
Z	Combination A,B,C,D,E	
M	Combination A,B,C	

Continued on the following page. ↗

Continued from the preceding page.

Standard Land Pattern Dimensions

Test Circuit

2

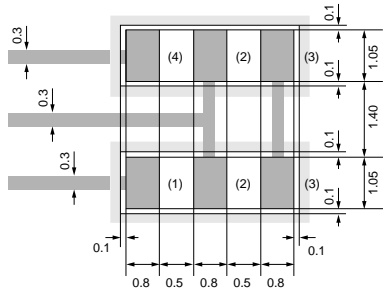

(1) : Input (2) : Ground (3) : Float (Signal Line) (4) : Output
It shows solder resist land pattern.

(in mm)

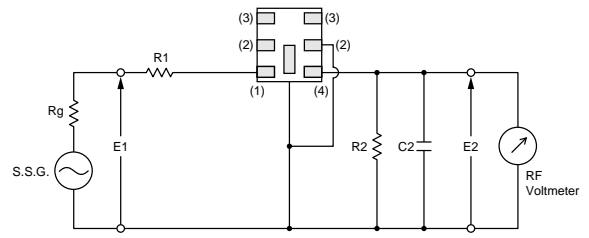

$R1+Rg=R2=330\Omega\pm5\%$, $Rg=50\Omega$
 $C2=10pF$ (Including stray capacitance and input capacitance of RF Voltmeter)
E1 : S.S.G. Output Voltage

- (1) : Input
- (2) : Ground
- (3) : Float
- (4) : Output

Frequency Characteristics

SFECED10M7FA00-R0

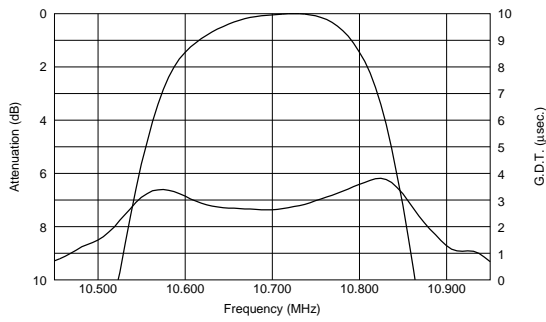

Frequency Characteristics (Spurious)

SFECED10M7FA00-R0

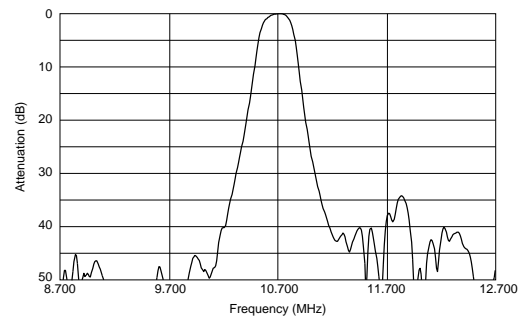

CERAFIL[®] (Filters/Traps/Discriminators) for Audio/Visual Equipment



CERAFIL[®] 10.7MHz Chip Type SFECV Series

SFECV10M7 series for FM-receivers are monolithic type ceramic filters which utilize the thickness expander mode of the piezoelectric ceramic. SFECV series and PFWCC(kHz filter for AM receiver) enable customers to make AM/FM set so thin, and it can be of help to the total chip circuit.

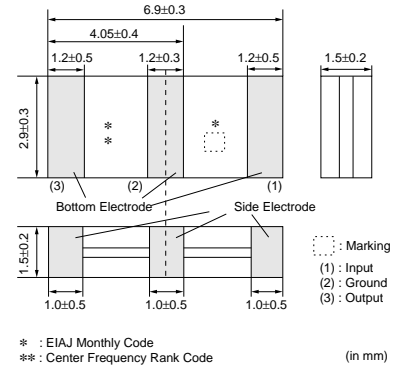

■ Features

1. Piezoelectric element is connected in the sandwich shape by heat resistant substrate, thus it has excellent mechanical strength, and it is suitable for automatic mounting.
2. Various bandwidths are available. Select a suitable type in accordance with the desired selectivity.

■ Applications

1. Small, thin radios
2. Automotive radios
3. Headphone stereos

Part Number	Center Frequency (fo) (MHz)	3dB Bandwidth (kHz)	Attenuation (kHz)	Insertion Loss (dB)	Spurious Attenuation (dB)	Input/Output Impedance (ohm)
SFECV10M7KA00-R0	10.700 ±30kHz	110 ±30kHz	320 max.	6.0 ±2.0dB	35 min.	330
SFECV10M7JA00-R0	10.700 ±30kHz	150 ±40kHz	380 max.	5.5 ±2.0dB	35 min.	330
SFECV10M7HA00-R0	10.700 ±30kHz	180 ±40kHz	470 max.	4.0 ±2.0dB	35 min.	330
SFECV10M7GA00-R0	10.700 ±30kHz	230 ±50kHz	510 max.	3.5 ±2.0dB	35 min.	330
SFECV10M7FA00-R0	10.700 ±30kHz	280 ±50kHz	590 max.	3.0 ±2.0dB	35 min.	330

Attenuation Bandwidth : at 20dB loss point Area of Spurious Attenuation : [within 9MHz to 12MHz]
Insertion Loss: at minimum loss point
Center frequency (fo) defined by the center of 3dB bandwidth.
The order quantity should be an integral multiple of the "Minimum Quantity" shown in the package page.

■ Standard Center Frequency Rank Code

CODE	30kHz Step	25kHz Step
D	10.64MHz±30kHz	10.650MHz±25kHz
B	10.67MHz±30kHz	10.675MHz±25kHz
A	10.70MHz±30kHz	10.700MHz±25kHz
C	10.73MHz±30kHz	10.725MHz±25kHz
E	10.76MHz±30kHz	10.750MHz±25kHz
Z	Combination A,B,C,D,E	
M	Combination A,B,C	

Continued on the following page. ↗

Continued from the preceding page.

Standard Land Pattern Dimensions

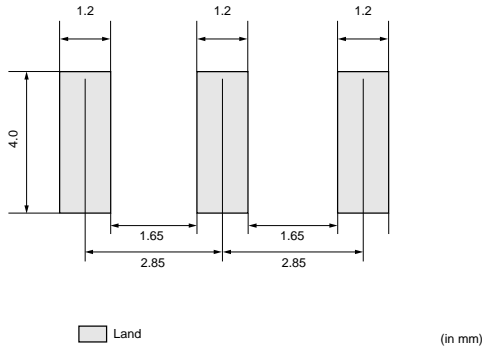

Test Circuit

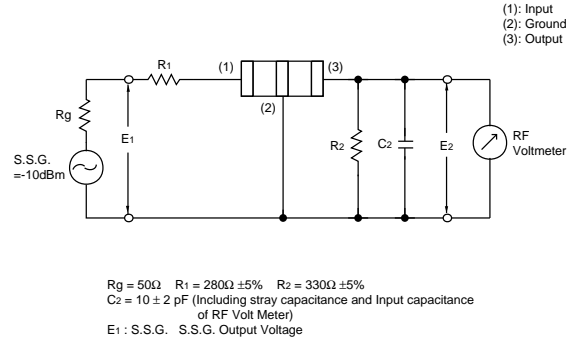

Frequency Characteristics

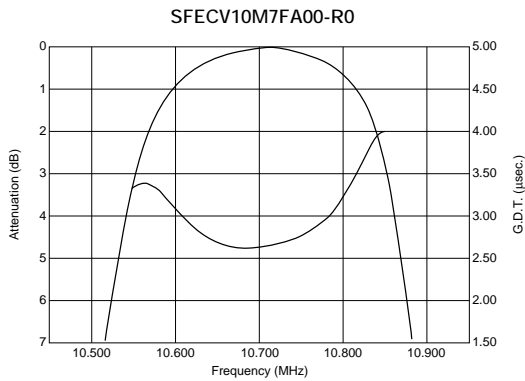
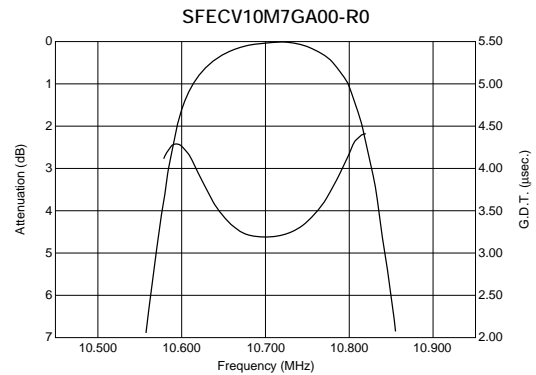
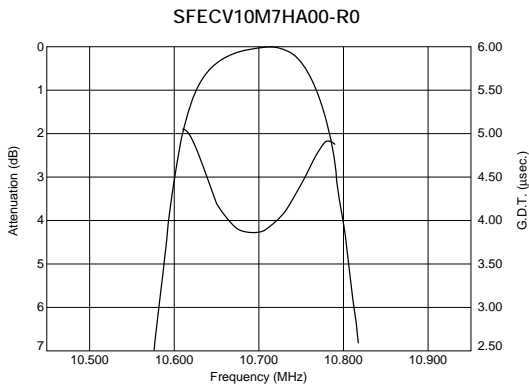
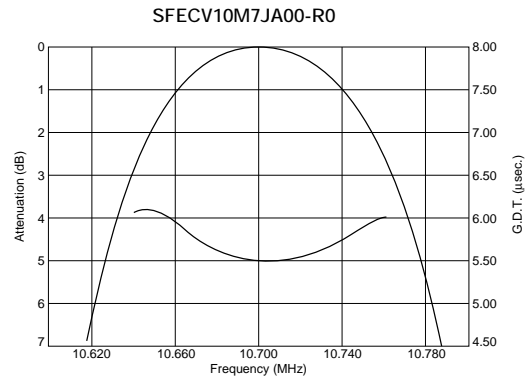
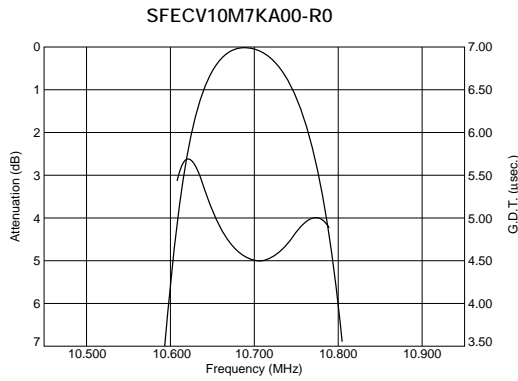

Frequency Characteristics (Spurious)

SFECV10M7KA00-R0

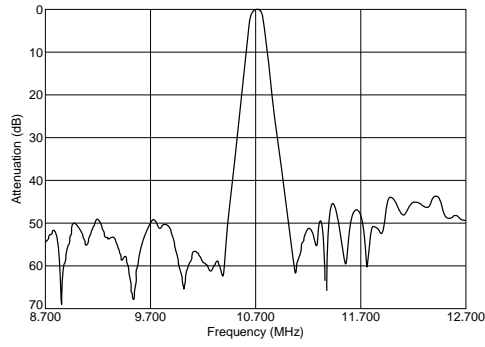

SFECV10M7JA00-R0

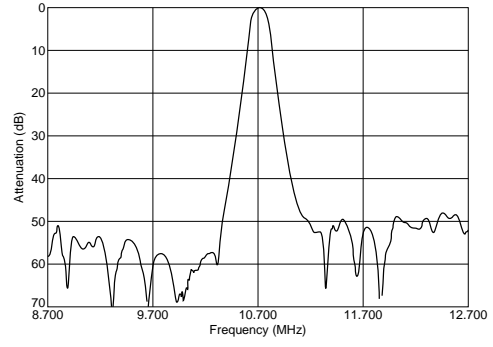

3

SFECV10M7HA00-R0

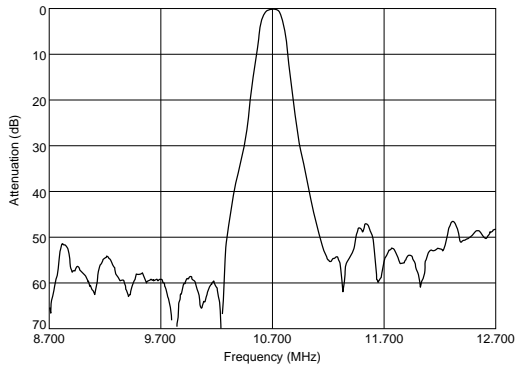

SFECV10M7GA00-R0

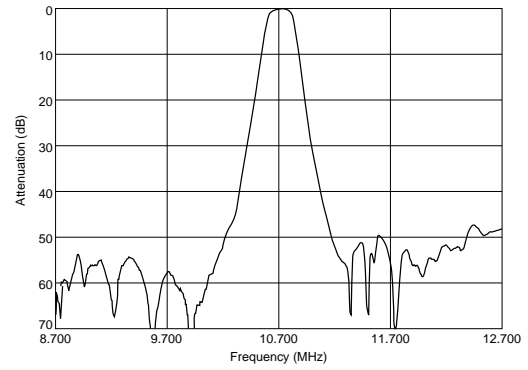

SFECV10M7FA00-R0

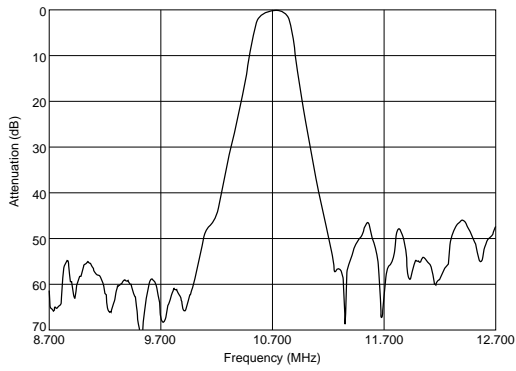

CERAFIL® (Filters/Traps/Discriminators) for Audio/Visual Equipment



CERAFIL® 10.7MHz Standard Lead Type

4

SFELA10M7 series for FM-receivers are monolithic type ceramic filters which use the thickness expander mode of the piezoelectric ceramic.

■ Features

1. These miniature filters have high mechanical strength.
2. Low loss, favorable waveform symmetry, and high selectivity
3. Various band widths are available for applications in wide to narrow bands.
4. Small dispersion and stable characteristics
5. Change in center frequency is typically within $\pm 30\text{ppm}/(\text{degree C})$ at -20 to $+80$ (degree C).
6. High reliability



SFELA10M7HA00-B0

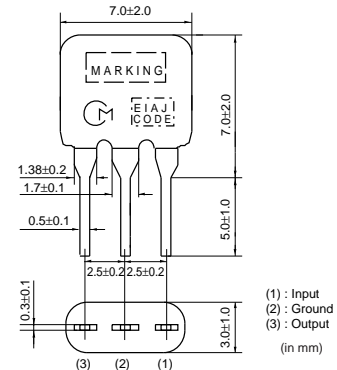

SFELA10M7GA00-B0

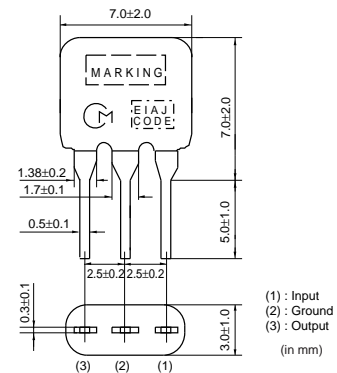

SFELA10M7FA00-B0

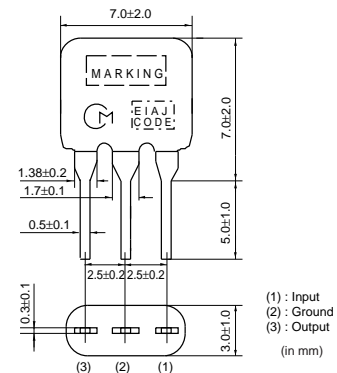

Part Number	Center Frequency (fo) (MHz)	3dB Bandwidth (kHz)	Attenuation (kHz)	Insertion Loss (dB)	Spurious Attenuation (dB)	Input/Output Impedance (ohm)
SFELA10M7HA00-B0	10.700 ±30kHz	180 ±40kHz	520 max.	7.0 max.	40 min.	330
SFELA10M7GA00-B0	10.700 ±30kHz	230 ±50kHz	570 max.	4.0 ±2.0dB	40 min.	330
SFELA10M7FA00-B0	10.700 ±30kHz	280 ±50kHz	650 max.	4.0 ±2.0dB	30 min.	330

Attenuation Bandwidth : at 20dB loss point Area of Spurious Attenuation : [within 9MHz to 12MHz]
Insertion Loss: at minimum loss point
Center frequency (fo) defined by the center of 3dB bandwidth.
The order quantity should be an integral multiple of the "Minimum Quantity" shown in the package page.



Standard Center Frequency Rank Code

CODE	30kHz Step	25kHz Step	Color Code
D	10.64MHz±30kHz	10.650MHz±25kHz	Black
B	10.67MHz±30kHz	10.675MHz±25kHz	Blue
A	10.70MHz±30kHz	10.700MHz±25kHz	Red
C	10.73MHz±30kHz	10.725MHz±25kHz	Orange
E	10.76MHz±30kHz	10.750MHz±25kHz	White
Z	Combination A,B,C,D,E		
M	Combination A,B,C		

Test Circuit

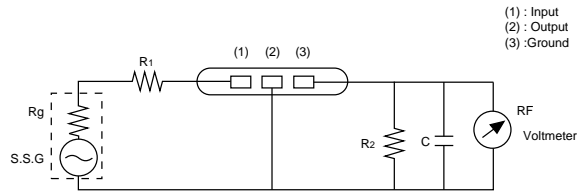

$R_g + R_1 = R_2 =$ Input and Output Impedance
 $C = 10\text{pF}$ (including stray capacitance and input capacitance of RF voltmeter.)

Frequency Characteristics

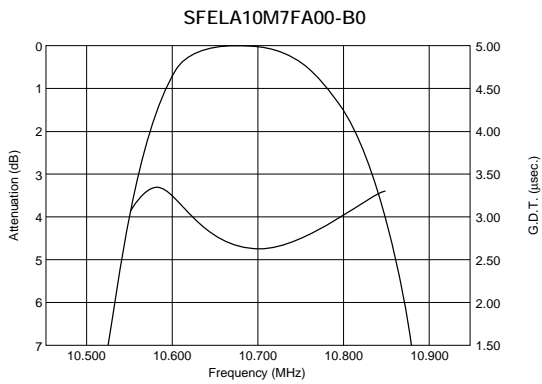
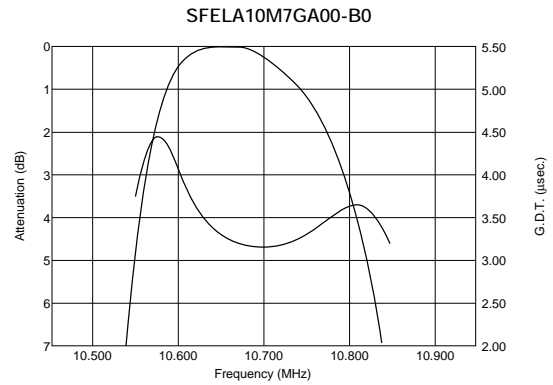
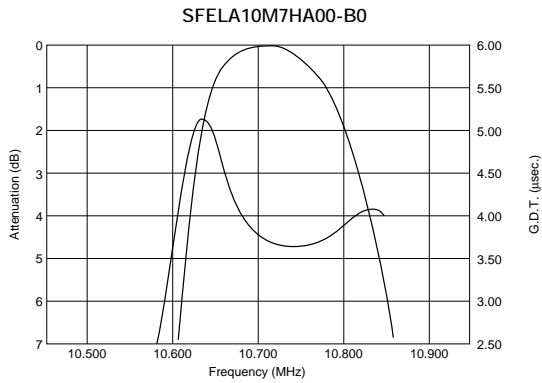

Frequency Characteristics (Spurious)

SFELA10M7HA00-B0

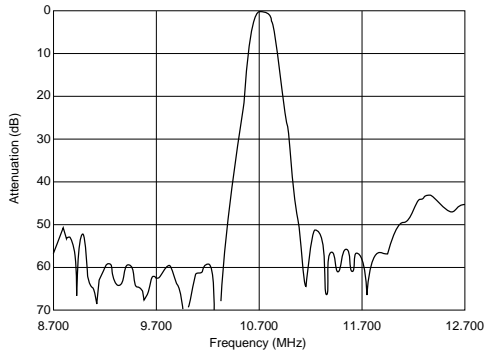

SFELA10M7GA00-B0

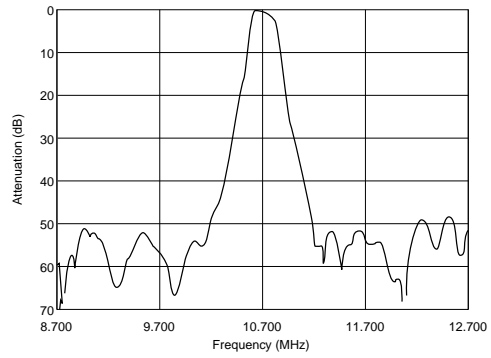

SFELA10M7FA00-B0

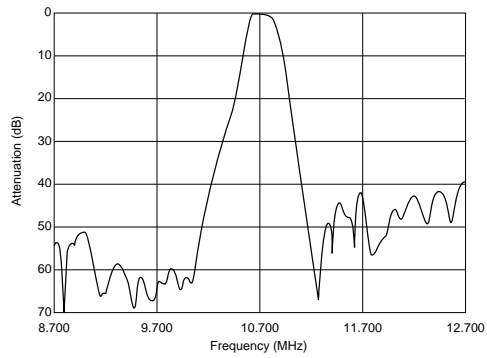

CERAFIL[®] (Filters/Traps/Discriminators) for Audio/Visual Equipment



CERAFIL[®] 10.7MHz Low Loss Type

SFELA10M7 series for FM-receivers are monolithic type ceramic filters which use the thickness expander mode of the piezoelectric ceramic.

■ Features

1. Insertion loss is 1 to 1.5dB lower than conventional products. These types are useful for elevating the sensitivity of sets.
2. Small dispersion and stable characteristics
3. Excellent shape factor of frequency response
4. Good waveform symmetry



SFELA10M7JAA0-B0

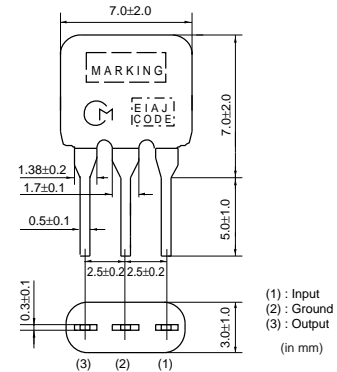

SFELA10M7HAA0-B0

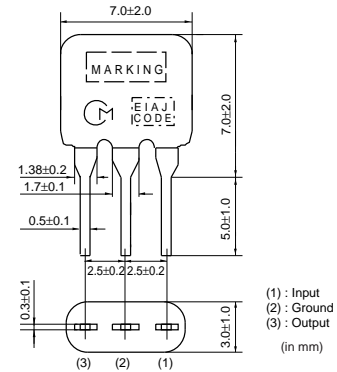

SFELA10M7GAA0-B0

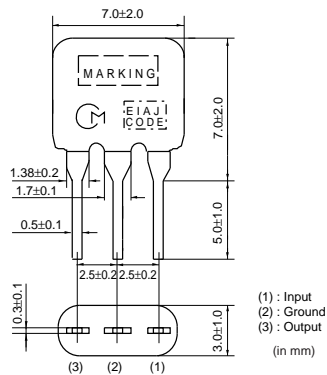

SFELA10M7FAA0-B0

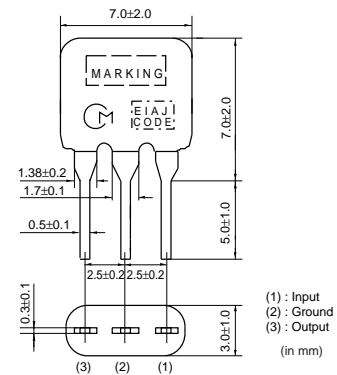

Part Number	Center Frequency (fo) (MHz)	3dB Bandwidth (kHz)	Attenuation (kHz)	Insertion Loss (dB)	Spurious Attenuation (dB)	Input/Output Impedance (ohm)
SFELA10M7JAA0-B0	10.700 ±30kHz	150 ±40kHz	360 max.	4.5 ±2.0dB	35 min.	330
SFELA10M7HAA0-B0	10.700 ±30kHz	180 ±40kHz	470 max.	3.5 ±1.5dB	35 min.	330
SFELA10M7GAA0-B0	10.700 ±30kHz	230 ±50kHz	520 max.	3.0 ±2.0dB	35 min.	330
SFELA10M7FAA0-B0	10.700 ±30kHz	280 ±50kHz	590 max.	2.5 ±2.0dB	30 min.	330

Attenuation Bandwidth : at 20dB loss point Area of Spurious Attenuation : [within 9MHz to 12MHz]

Insertion Loss: at minimum loss point

Center frequency (fo) defined by the center of 3dB bandwidth.

The order quantity should be an integral multiple of the "Minimum Quantity" shown in the package page.

Standard Center Frequency Rank Code

CODE	30kHz Step	25kHz Step	Color Code
D	10.64MHz±30kHz	10.650MHz±25kHz	Black
B	10.67MHz±30kHz	10.675MHz±25kHz	Blue
A	10.70MHz±30kHz	10.700MHz±25kHz	Red
C	10.73MHz±30kHz	10.725MHz±25kHz	Orange
E	10.76MHz±30kHz	10.750MHz±25kHz	White
Z	Combination A,B,C,D,E		
M	Combination A,B,C		

Test Circuit

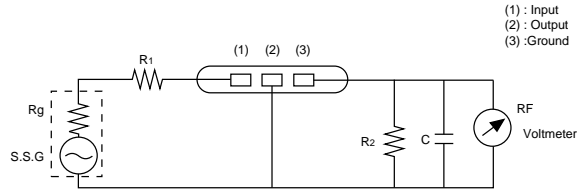

$R_g + R_1 = R_2 =$ Input and Output Impedance
 $C = 10\text{pF}$ (including stray capacitance and input capacitance of RF voltmeter.)

Frequency Characteristics

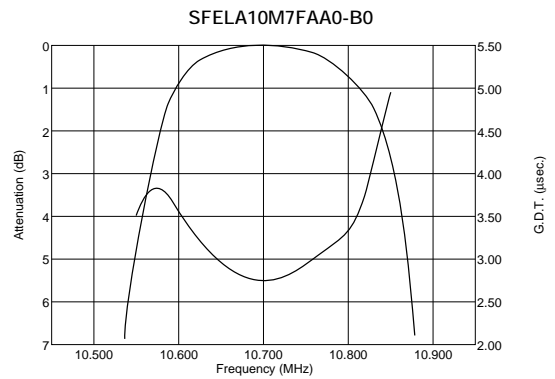
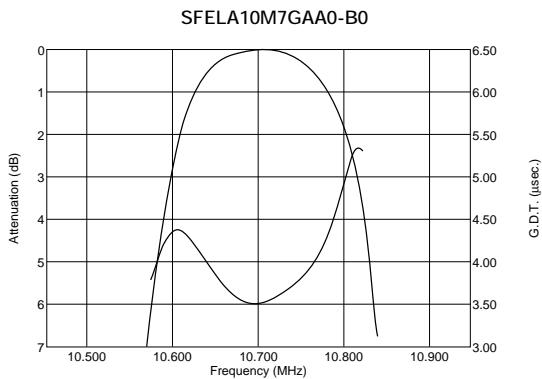
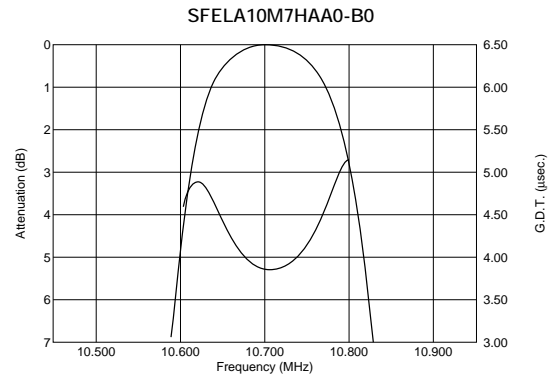
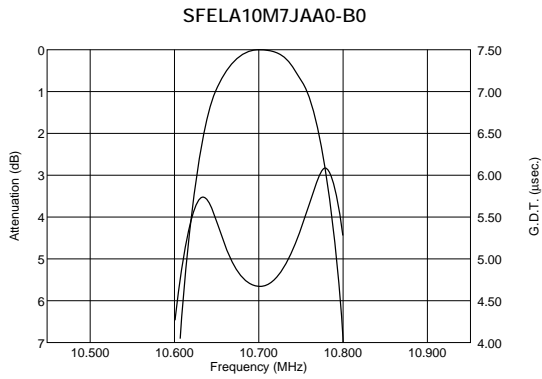

Frequency Characteristics (Spurious)

SFELA10M7JAA0-B0

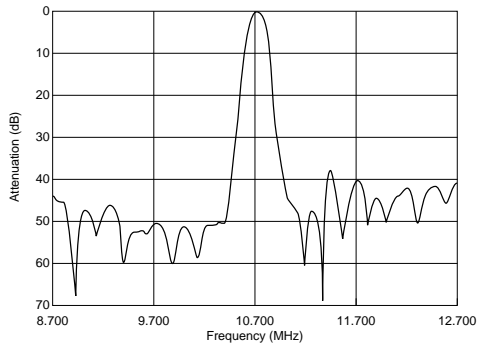

SFELA10M7HAA0-B0

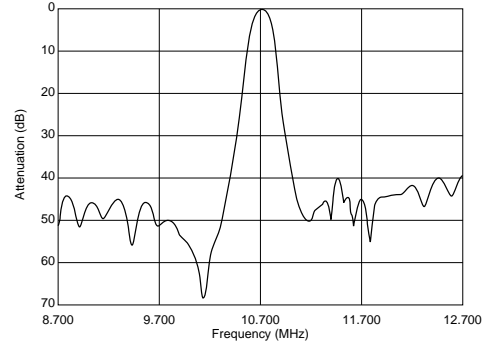

SFELA10M7GAA0-B0

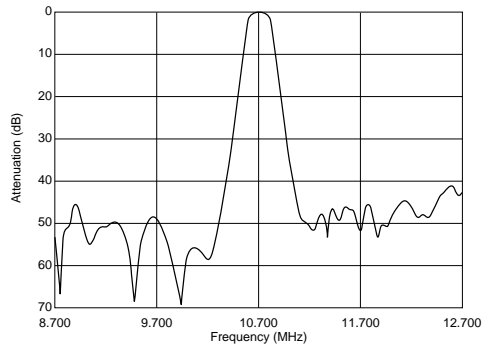

SFELA10M7FAA0-B0

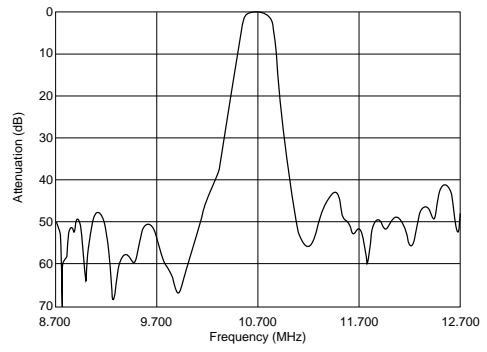

5

CERAFIL® (Filters/Traps/Discriminators) for Audio/Visual Equipment



CERAFIL® 10.7MHz Low Profile Type

6

SFELB10M7 series for FM-receivers are monolithic type ceramic filters which use the thickness expander mode of the piezoelectric ceramic.

■ Features

1. Installed height is 6.0 mm, making it well suited for compact, thin sets.
2. Environmental reliability is the same as those of the ceramic filter SFELA10M7 series.



SFELB10M7KA00-B0

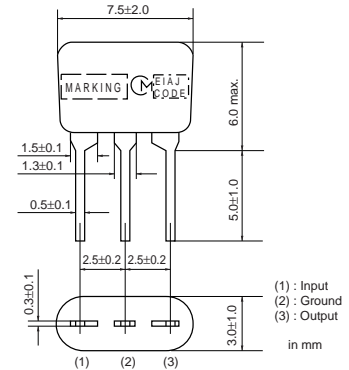

SFELB10M7JA00-B0

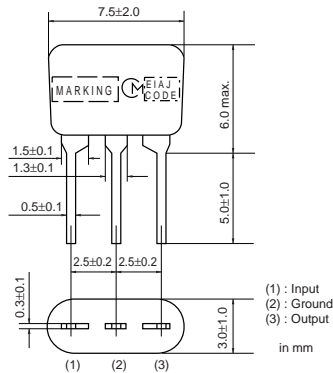

SFELB10M7HA00-B0

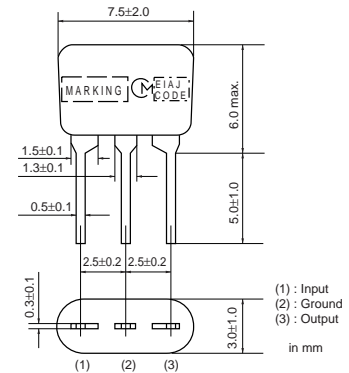

SFELB10M7GA00-B0

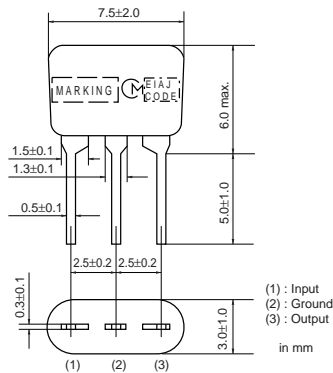

SFELB10M7FA00-B0

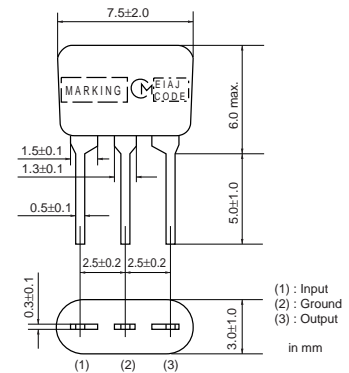

Part Number	Center Frequency (fo) (MHz)	3dB Bandwidth (kHz)	Attenuation (kHz)	Insertion Loss (dB)	Spurious Attenuation (dB)	Input/Output Impedance (ohm)
SFELB10M7KA00-B0	10.700 ±30kHz	110 ±30kHz	350 max.	7.0 ±2.0dB	30 min.	330
SFELB10M7JA00-B0	10.700 ±30kHz	150 ±40kHz	360 max.	4.5 ±2.0dB	35 min.	330
SFELB10M7HA00-B0	10.700 ±30kHz	180 ±40kHz	470 max.	3.5 ±2.0dB	35 min.	330
SFELB10M7GA00-B0	10.700 ±30kHz	230 ±50kHz	570 max.	3.0 ±2.0dB	40 min.	330
SFELB10M7FA00-B0	10.700 ±30kHz	280 ±50kHz	650 max.	3.0 ±2.0dB	30 min.	330

Attenuation Bandwidth : at 20dB loss point Area of Spurious Attenuation : [within 9MHz to 12MHz]
Insertion Loss: at minimum loss point
Center frequency (fo) defined by the center of 3dB bandwidth.
The order quantity should be an integral multiple of the "Minimum Quantity" shown in the package page.

Standard Center Frequency Rank Code

CODE	30kHz Step	25kHz Step	Color Code
D	10.64MHz±30kHz	10.650MHz±25kHz	Black
B	10.67MHz±30kHz	10.675MHz±25kHz	Blue
A	10.70MHz±30kHz	10.700MHz±25kHz	Red
C	10.73MHz±30kHz	10.725MHz±25kHz	Orange
E	10.76MHz±30kHz	10.750MHz±25kHz	White
Z	Combination A,B,C,D,E		
M	Combination A,B,C		

Test Circuit

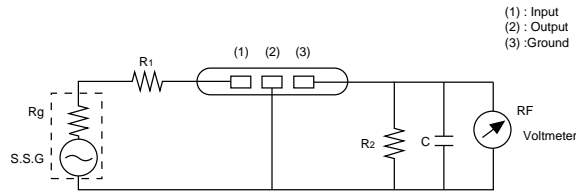

$R_g + R_1 = R_2 =$ Input and Output Impedance
 $C = 10\text{pF}$ (including stray capacitance and input capacitance of RF voltmeter.)

Frequency Characteristics

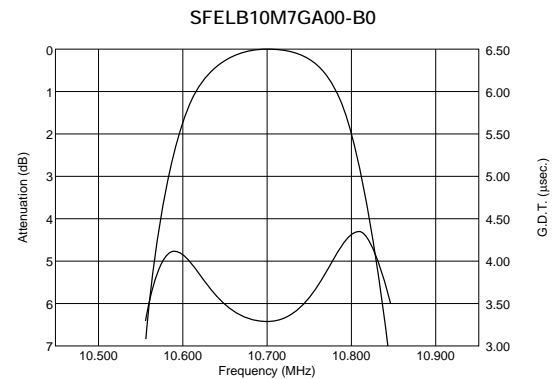
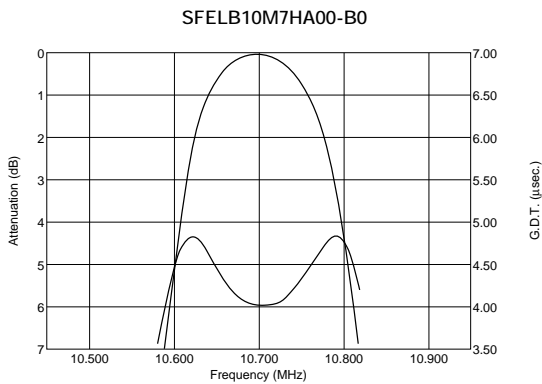
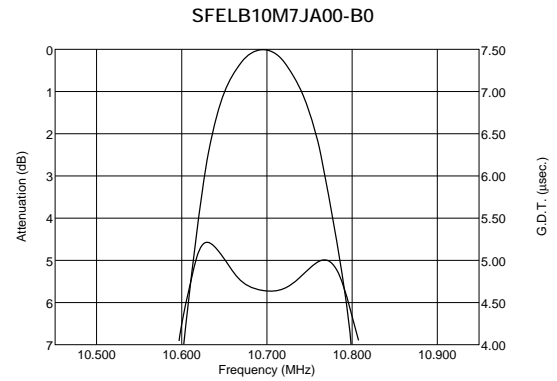
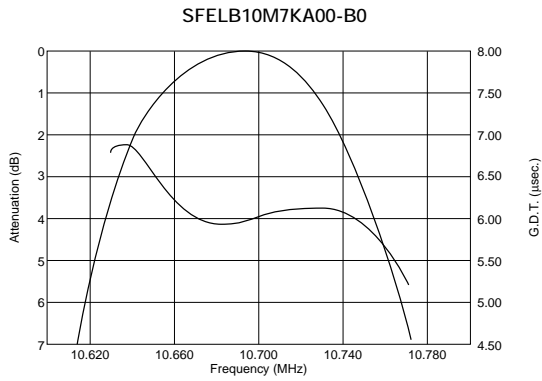

Continued on the following page. ↗

↳ Continued from the preceding page.

Frequency Characteristics

SFELB10M7FA00-B0

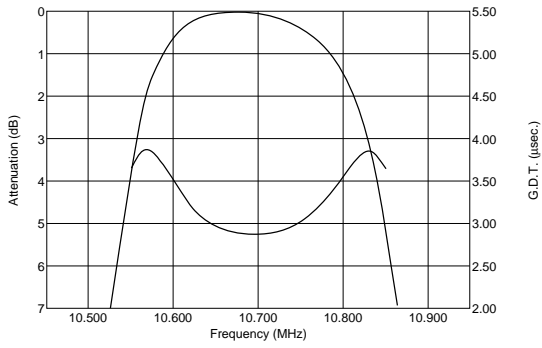

6

Frequency Characteristics (Spurious)

SFELB10M7KA00-B0

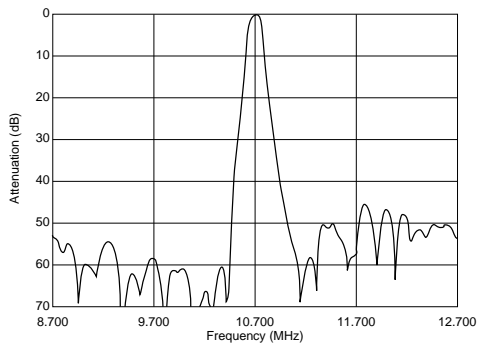

SFELB10M7JA00-B0

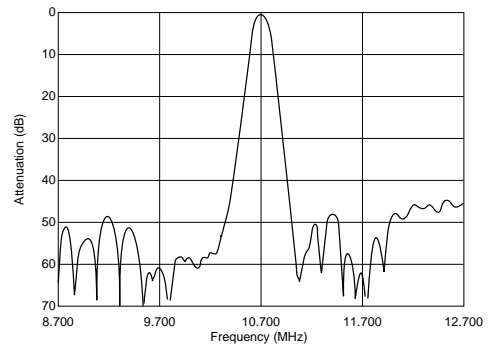

SFELB10M7HA00-B0

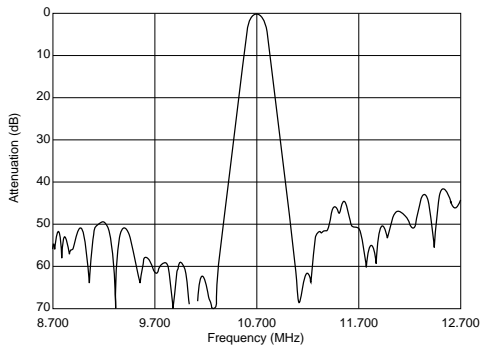

SFELB10M7GA00-B0

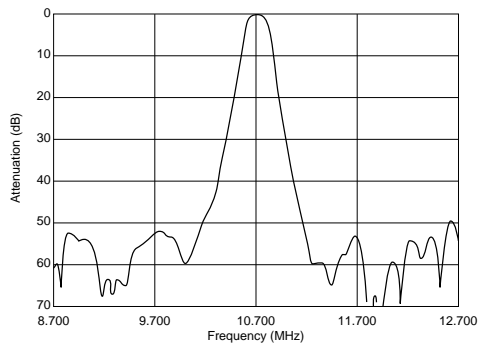

SFELB10M7FA00-B0

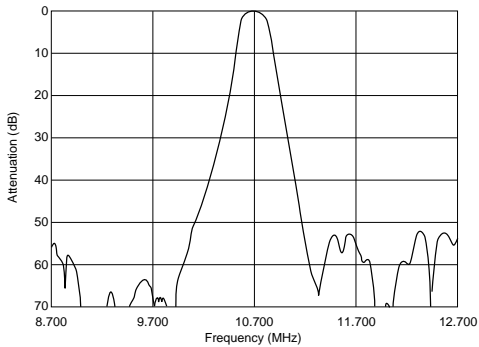

CERAFIL[®] (Filters/Traps/Discriminators) for Audio/Visual Equipment



CERAFIL[®] 10.7MHz Low Spurious Response Type

SFELA10M7 series for FM-receivers are monolithic type ceramic filters which use the thickness expander mode of the piezoelectric ceramic.

■ Features

These types have lower spurious response compared to the standard filters.

7



SFELA10M7KAB0-B0

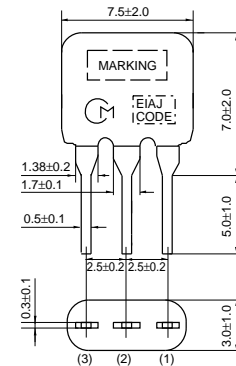

SFELA10M7JAB0-B0

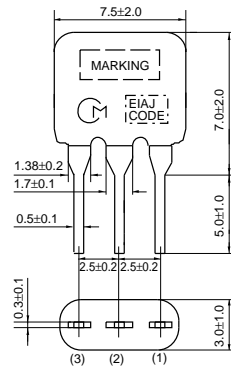

SFELA10M7HAB0-B0

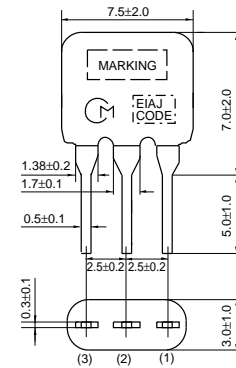

SFELA10M7GAB0-B0

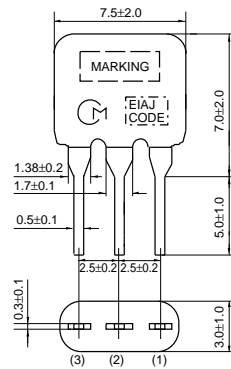

SFELA10M7FAB0-B0

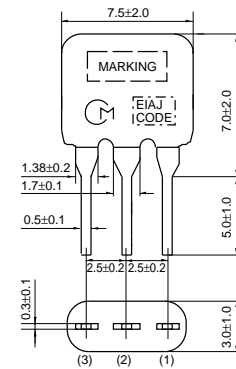

Part Number	Center Frequency (fo) (MHz)	3dB Bandwidth (kHz)	Attenuation (kHz)	Insertion Loss (dB)	Spurious Attenuation (dB)	Input/Output Impedance (ohm)
SFELA10M7KAB0-B0	10.700 ±30kHz	110 ±30kHz	350 max.	7.0 ±2.0dB	45/30 min.	330
SFELA10M7JAB0-B0	10.700 ±30kHz	150 ±40kHz	380 max.	5.5 ±2.0dB	45 min.	330
SFELA10M7HAB0-B0	10.700 ±30kHz	180 ±40kHz	520 max.	5.0 ±2.0dB	45 min.	330
SFELA10M7GAB0-B0	10.700 ±30kHz	230 ±50kHz	570 max.	3.0 ±2.0dB	45 min.	330
SFELA10M7FAB0-B0	10.700 ±30kHz	280 ±50kHz	650 max.	3.0 ±2.0dB	45 min.	330

Attenuation Bandwidth : at 20dB loss point Area of Spurious Attenuation : [within 9MHz to fo / fo to 12MHz]

Insertion Loss: at minimum loss point

Center frequency (fo) defined by the center of 3dB bandwidth.

The order quantity should be an integral multiple of the "Minimum Quantity" shown in the package page.

Standard Center Frequency Rank Code

CODE	30kHz Step	25kHz Step	Color Code
D	10.64MHz±30kHz	10.650MHz±25kHz	Black
B	10.67MHz±30kHz	10.675MHz±25kHz	Blue
A	10.70MHz±30kHz	10.700MHz±25kHz	Red
C	10.73MHz±30kHz	10.725MHz±25kHz	Orange
E	10.76MHz±30kHz	10.750MHz±25kHz	White
Z	Combination A,B,C,D,E		
M	Combination A,B,C		

7

Test Circuit

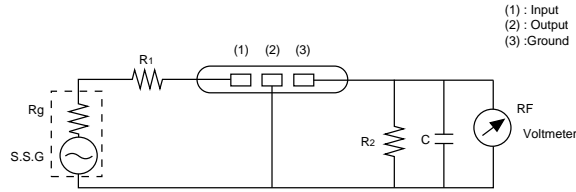

$R_g + R_1 = R_2 =$ Input and Output Impedance
 $C = 10\text{pF}$ (including stray capacitance and input capacitance of RF voltmeter.)

Frequency Characteristics

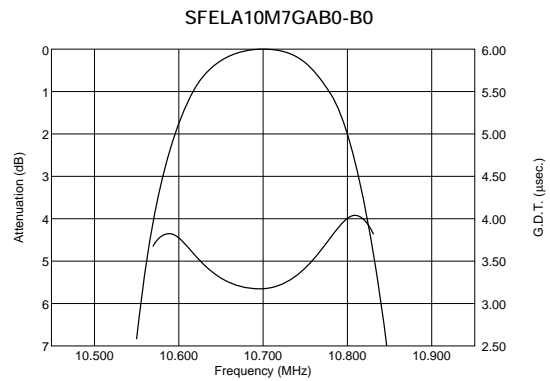
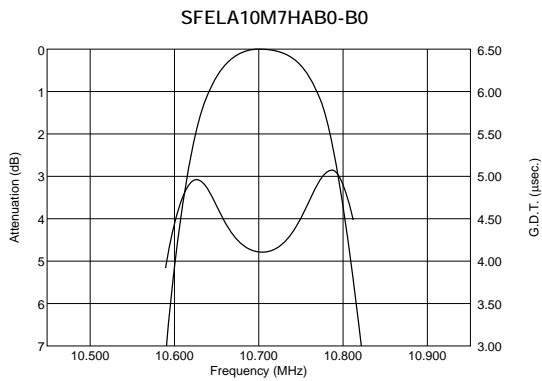
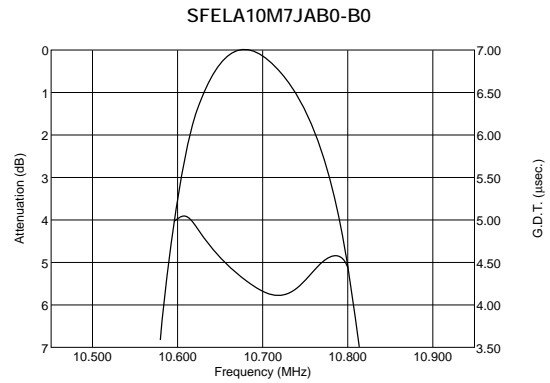
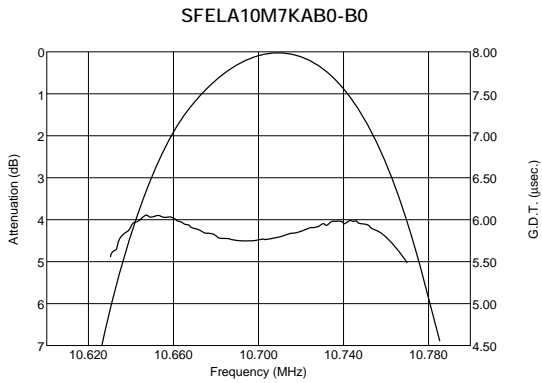

Continued on the following page. ↗

↳ Continued from the preceding page.

■ Frequency Characteristics

SFELA10M7FAB0-B0

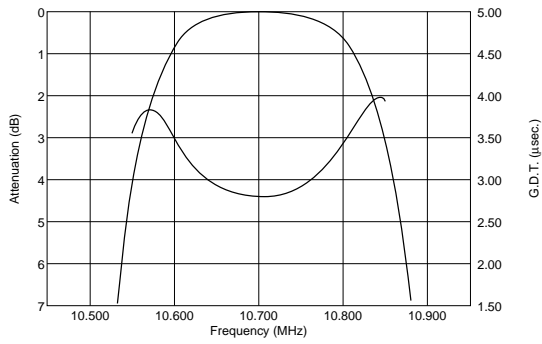

7

■ Frequency Characteristics (Spurious)

SFELA10M7KAB0-B0

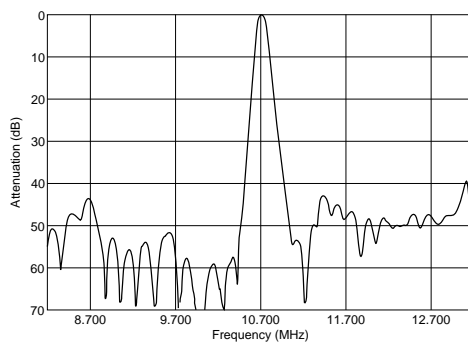

SFELA10M7JAB0-B0

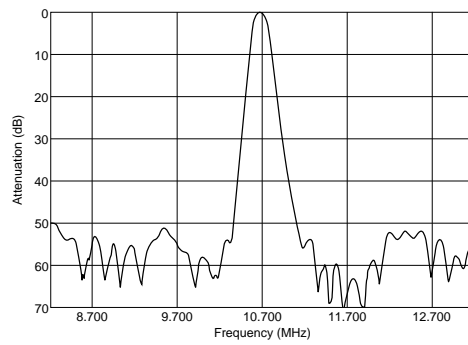

SFELA10M7HAB0-B0

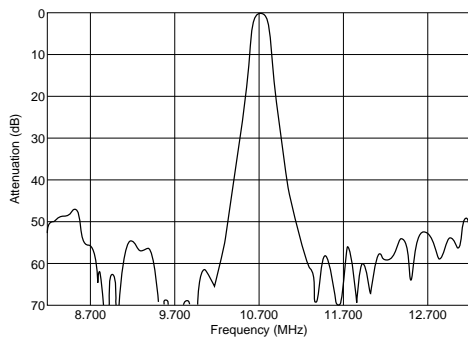

SFELA10M7GAB0-B0

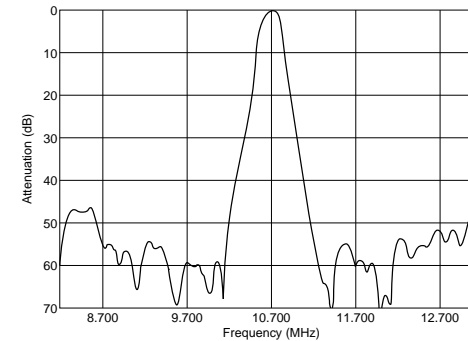

SFELA10M7FAB0-B0

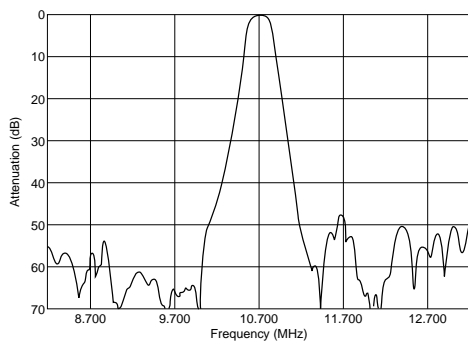

CERAFIL[®] (Filters/Traps/Discriminators) for Audio/Visual Equipment



CERAFIL[®] 10.7MHz Wide Bandwidth Type

SFELA10M7 series for FM-receivers are monolithic type ceramic filters which use the thickness expander mode of the piezoelectric ceramic.

■ Features

Realizes widerband characteristics not obtained by conventional ceramic filters.

8



SFELA10M7EA00-B0

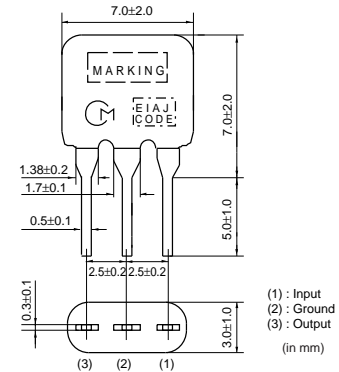

SFELA10M7DF00-B0

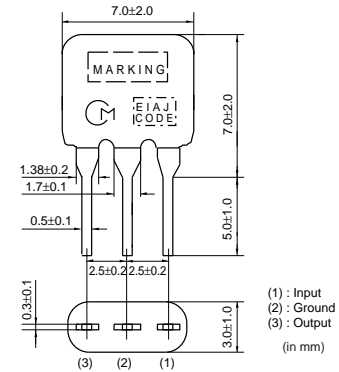

Part Number	Center Frequency (fo) (MHz)	Nominal Center Frequency (fn) (MHz)	3dB Bandwidth (kHz)	Attenuation (kHz)	Insertion Loss (dB)	Spurious Attenuation (dB)	Input/Output Impedance (ohm)
SFELA10M7EA00-B0	10.700 ±30kHz	-	330 ±50kHz	680 max.	4.0 ±2.0dB	30 min.	330
SFELA10M7DF00-B0	-	10.700	fn±175 min.	950 max.	3.0 ±2.0dB	20 min.	470

Attenuation Bandwidth : at 20dB loss point Area of Spurious Attenuation : [within 8MHz to 12MHz]
Insertion Loss: at minimum loss point
Center frequency (fo) defined by the center of 3dB bandwidth.
(fn) means nominal center frequency.
The order quantity should be an integral multiple of the "Minimum Quantity" shown in the package page.

■ Standard Center Frequency Rank Code

CODE	30kHz Step	25kHz Step	Color Code
D	10.64MHz±30kHz	10.650MHz±25kHz	Black
B	10.67MHz±30kHz	10.675MHz±25kHz	Blue
A	10.70MHz±30kHz	10.700MHz±25kHz	Red
C	10.73MHz±30kHz	10.725MHz±25kHz	Orange
E	10.76MHz±30kHz	10.750MHz±25kHz	White
Z	Combination A,B,C,D,E		
M	Combination A,B,C		

Test Circuit

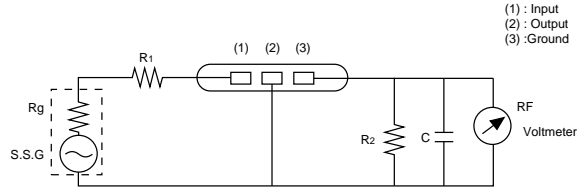

$R_g + R_1 = R_2 =$ Input and Output Impedance
 $C = 10\text{pF}$ (Including stray capacitance and input capacitance of RF voltmeter.)

Frequency Characteristics

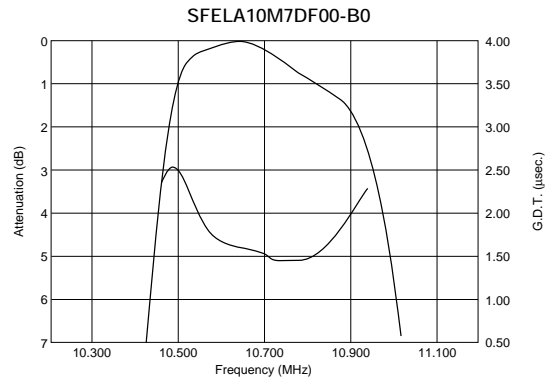
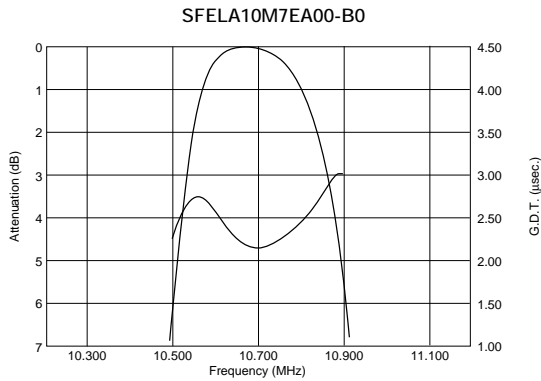

Frequency Characteristics (Spurious)

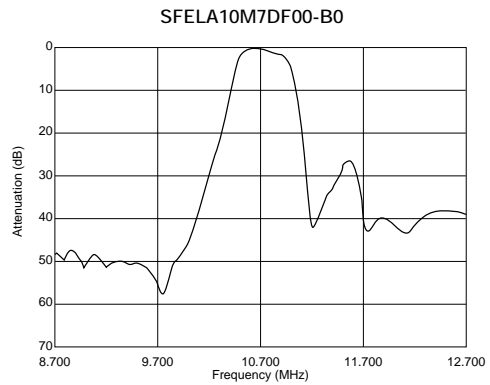
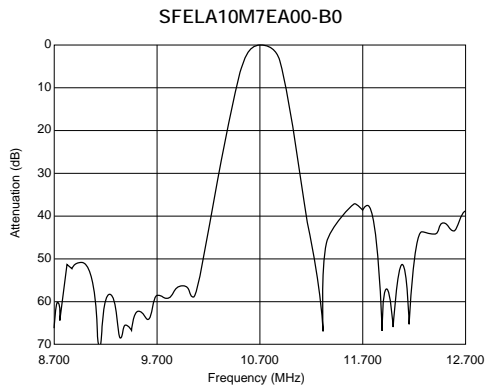

CERAFIL® (Filters/Traps/Discriminators) for Audio/Visual Equipment



CERAFIL® 10.7MHz Narrow Bandwidth Type

■ Features

SFELA10M7LFTA/KAH0, SFVLA/SFKLA series realizes narrower band characteristics not obtained by conventional ceramic filters. Besides, low spurious and temperature characteristics are stable. This series is suitable for European car-audio or AM up conversion use that needs narrow band characteristics.

9



SFVLA10M7MF00-B0

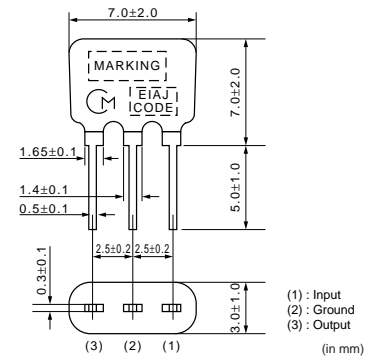

SFVLA10M7LF00-B0

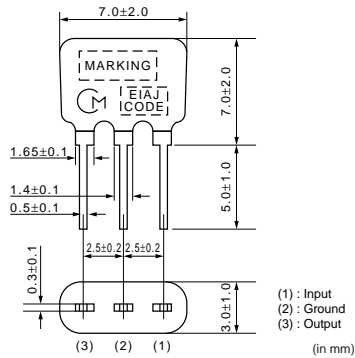

SFKLA10M7NL00-B0

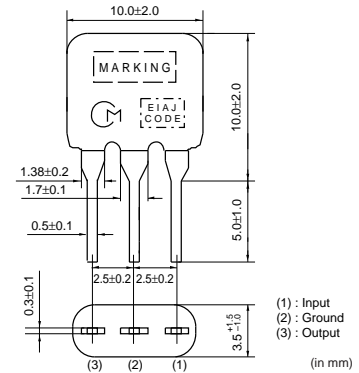

SFELA10M7LFTA-B0

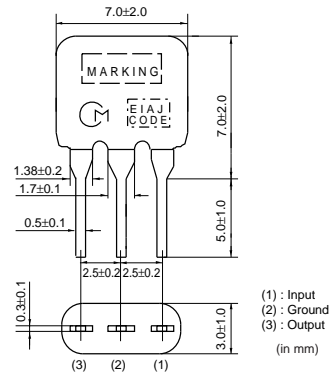

SFELA10M7KAH0-B0

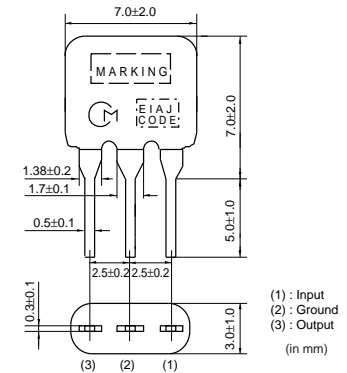

Part Number	Center Frequency (fo) (MHz)	Nominal Center Frequency (fn) (MHz)	3dB Bandwidth (kHz)	Attenuation (kHz)	Insertion Loss (dB)	Spurious Attenuation (dB)	Input/Output Impedance (ohm)
SFVLA10M7MF00-B0	-	10.700	fn±13 min.	135 max.	5.0 ±2.0dB	35 min.	330
SFVLA10M7LF00-B0	-	10.700	fn±25 min.	-	5.5 ±2.5dB	30 min.	330
SFKLA10M7NL00-B0	10.700 ±15kHz	-	20 min.	95 max.	6.0 max.	24 min.	600
SFELA10M7LFTA-B0	-	10.700	fn±25 min.	280 max.	7.0 ±2.0dB	30 min.	330
SFELA10M7KAH0-B0	10.700 ±30kHz	-	110 ±30kHz	350 max.	7.0 ±2.0dB	30 min.	330

Attenuation Bandwidth : at 20dB loss point Area of Spurious Attenuation : [within 9MHz to 12MHz]

Insertion Loss: at minimum loss point

Center frequency (fo) defined by the center of 3dB bandwidth.

The order quantity should be an integral multiple of the "Minimum Quantity" shown in the package page.

Standard Center Frequency Rank Code (SFELA10M7KAH0-B0)

CODE	30kHz Step	25kHz Step	Color Code
D	10.64MHz±30kHz	10.650MHz±25kHz	Black
B	10.67MHz±30kHz	10.675MHz±25kHz	Blue
A	10.70MHz±30kHz	10.700MHz±25kHz	Red
C	10.73MHz±30kHz	10.725MHz±25kHz	Orange
E	10.76MHz±30kHz	10.750MHz±25kHz	White
Z	Combination A,B,C,D,E		
M	Combination A,B,C		

Test Circuit

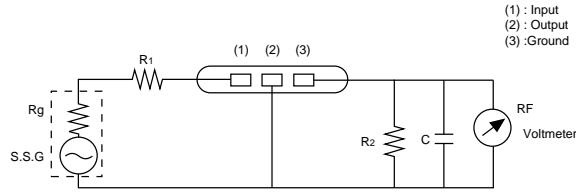

$R_g + R_1 = R_2 =$ Input and Output Impedance
 $C = 10\text{pF}$ (including stray capacitance and input capacitance of RF voltmeter.)

Frequency Characteristics

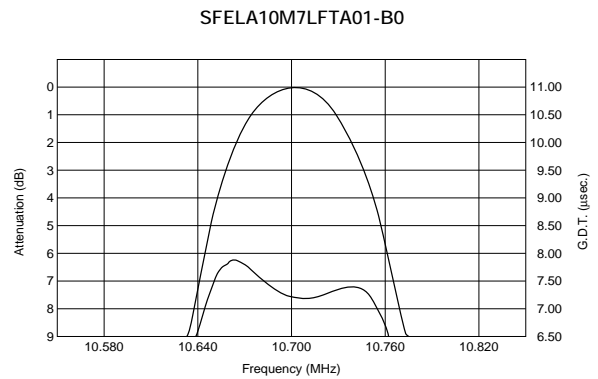
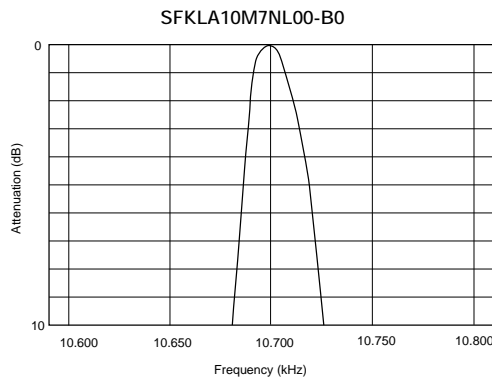
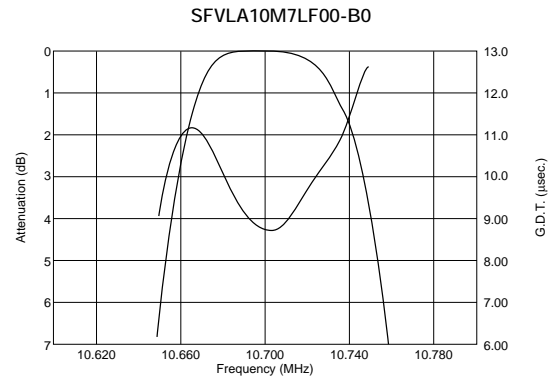
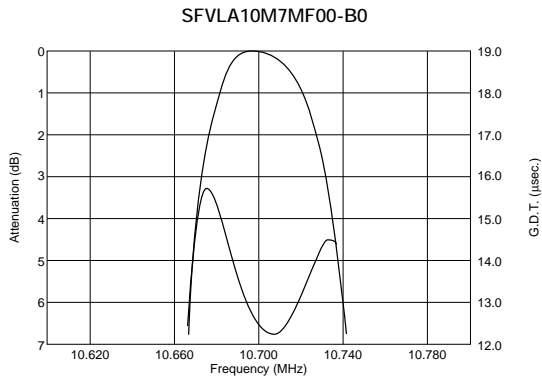

Continued on the following page. ↗

Continued from the preceding page.

Frequency Characteristics

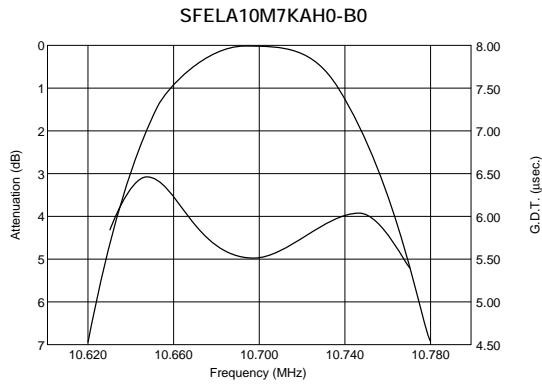

9

Frequency Characteristics (Spurious)

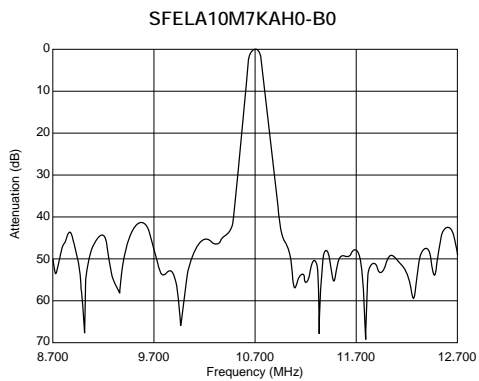
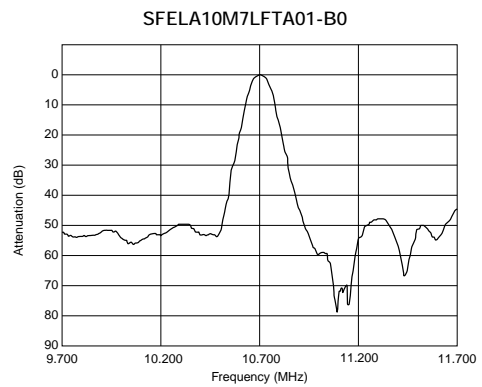
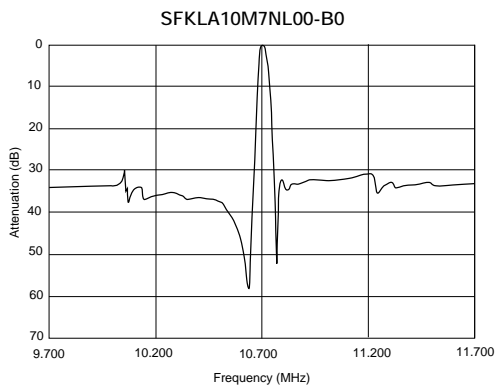
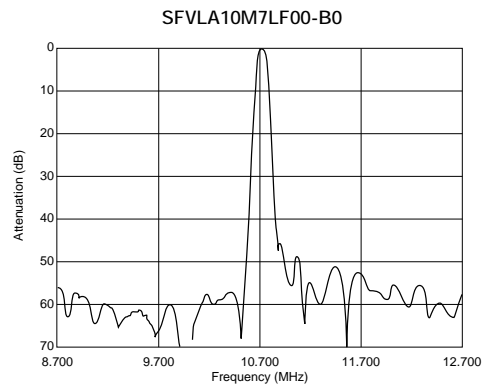
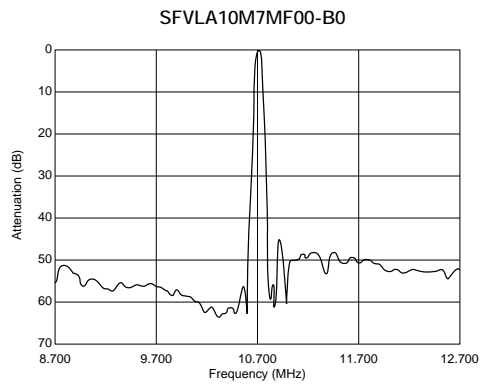

CERAFIL® (Filters/Traps/Discriminators) for Audio/Visual Equipment



CERAFIL® 10.7MHz for FM-IF Tuners

SFELA10M7 series for FM-receivers are monolithic type ceramic filters which use the thickness expander mode of the piezoelectric ceramic.

■ Features

1. Little dispersion of amplitude characteristics and phase characteristics (G. D. T. characteristics)
2. The SFELA10M7G_X series has G. D. T. characteristics and is useful for obtaining low distortion. SFELA10M7F_L series, in these ceramic filters, being in harmony with flatness of G. D. T., roundness of the amplitude and selectivity characteristics, therefore, these ceramic filters are suitable to high-grade stereo tuners. Even in mismatching conditions, they can keep little distortion because of low Qm of ceramic material. The SFELA10M7FA0G series is based on SFELA10M7FA00/GA00/HA00, and it obtains high selectivity with low loss. There is little dispersion of amplitude and G. D. T. characteristics, and low distortion rate can be obtained.
3. All products are inspected the flatness of G. D. T. characteristics.



SFELA10M7JAXE-B0

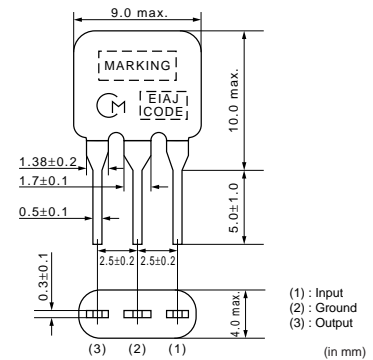

SFELA10M7HAXD-B0

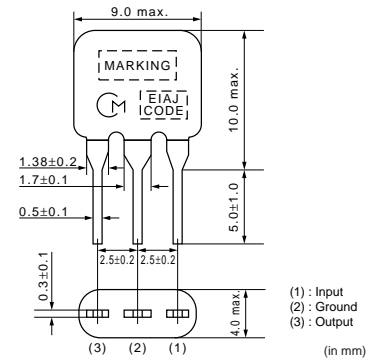

SFELA10M7HA0G-B0

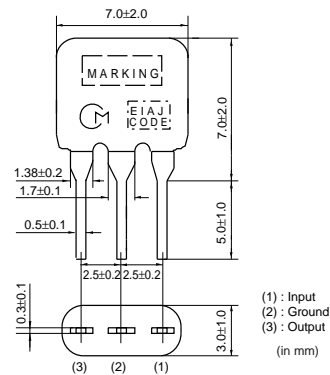

SFELA10M7GAXX-B0

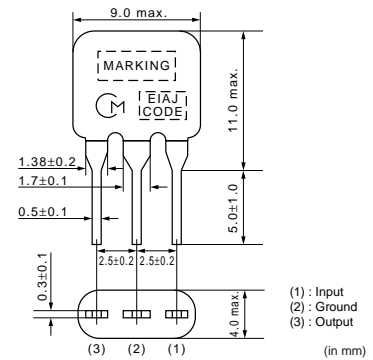

SFELA10M7GAXA-B0

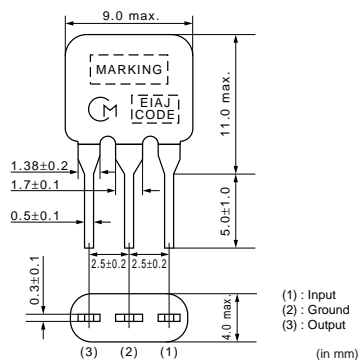

SFELA10M7GALP03-B0

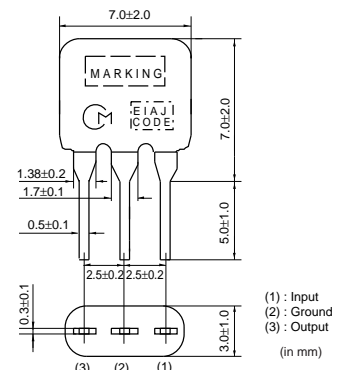

Continued on the following page.

Continued from the preceding page.

SFELA10M7GALM-B0

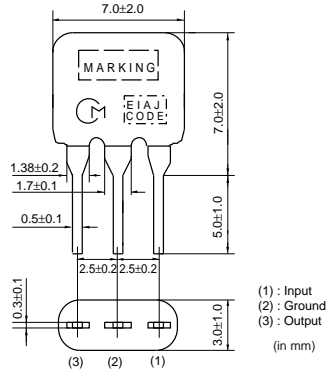

SFELA10M7GA0G-B0

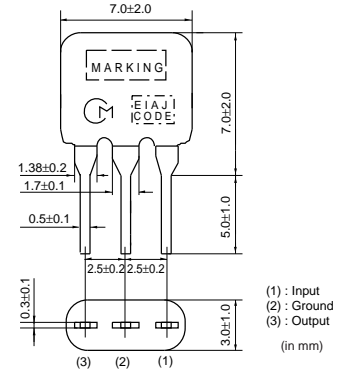

SFELA10M7FALL-B0

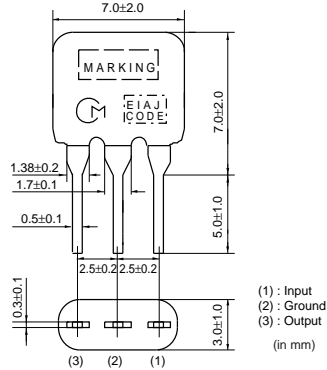

SFELA10M7FA0G-B0

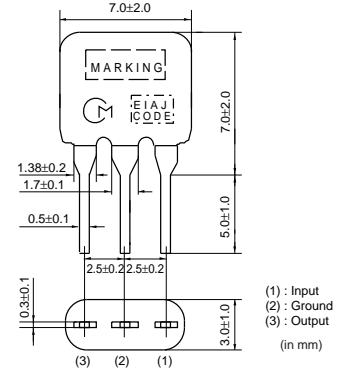

10

Part Number	Center Frequency (fo) (MHz)	3dB Bandwidth (kHz)	Attenuation (kHz)	Insertion Loss (dB)	Spurious Attenuation (dB)	GDT Bandwidth (kHz)	Input/Output Impedance (ohm)
SFELA10M7JAXE-B0	10.700 ±30kHz	150 ±30kHz	500 max.	14.0 max.	35 min.	fo±50 min. [within 0.15µsec.]	330
SFELA10M7HAXD-B0	10.700 ±30kHz	180 ±30kHz	530 max.	14.0 max.	33 min.	fo±60 min. [within 0.15µsec.]	330
SFELA10M7HA0G-B0	10.700 ±30kHz	180 ±40kHz	520 max.	7.0 max.	40 min.	fo±45 min. [within 0.5µsec.]	330
SFELA10M7GAXX-B0	10.700 ±30kHz	250 ±40kHz	670 max.	12.0 max.	25 min.	fo±110 min. [within 0.2µsec.]	330
SFELA10M7GAXA-B0	10.700 ±30kHz	220 ±40kHz	610 max.	12.5 max.	30 min.	fo±80 min. [within 0.15µsec.]	330
SFELA10M7GALP03-B0	10.700 ±30kHz	250 ±50kHz	650 max.	10.0 max.	30 min.	fo±65 min. [within 0.25µsec.]	330
SFELA10M7GALM-B0	10.700 ±30kHz	230 ±50kHz	600 max.	9.0 ±2.0dB	30 min.	fo±60 min. [within 0.25µsec.]	330
SFELA10M7GA0G-B0	10.700 ±30kHz	230 ±50kHz	600 max.	7.0 max.	40 min.	fo±60 min. [within 0.5µsec.]	330
SFELA10M7FALL-B0	10.700 ±30kHz	280 ±50kHz	700 max.	7.0 ±2.0dB	25 min.	fo±70 min. [within 0.25µsec.]	330
SFELA10M7FA0G-B0	10.700 ±30kHz	280 ±50kHz	650 max.	4.0 ±2.0dB	30 min.	fo±85 min. [within 0.5µsec.]	330

Attenuation Bandwidth : at 20dB loss point Area of Spurious Attenuation : [within 9MHz to 12MHz]

Insertion Loss: at minimum loss point

Center frequency (fo) defined by the center of 3dB bandwidth.

The order quantity should be an integral multiple of the "Minimum Quantity" shown in the package page.

Standard Center Frequency Rank Code

CODE	30kHz Step	25kHz Step	Color Code
D	10.64MHz±30kHz	10.650MHz±25kHz	Black
B	10.67MHz±30kHz	10.675MHz±25kHz	Blue
A	10.70MHz±30kHz	10.700MHz±25kHz	Red
C	10.73MHz±30kHz	10.725MHz±25kHz	Orange
E	10.76MHz±30kHz	10.750MHz±25kHz	White
Z	Combination A,B,C,D,E		
M	Combination A,B,C		

Continued on the following page. ↗

Continued from the preceding page.

Test Circuit

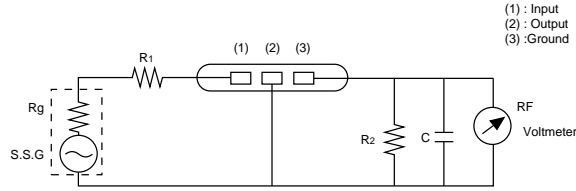

$R_g + R_1 = R_2 =$ Input and Output Impedance
 $C = 10\text{pF}$ (Including stray capacitance and input capacitance of RF voltmeter.)

Frequency Characteristics

10

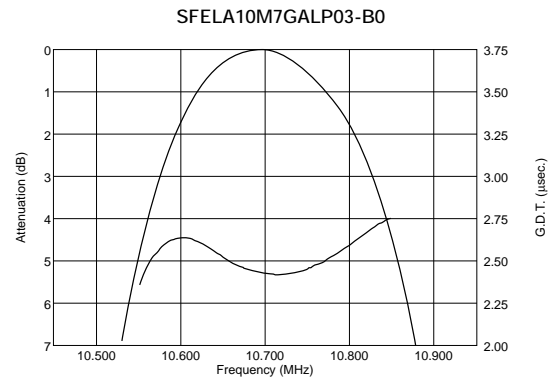
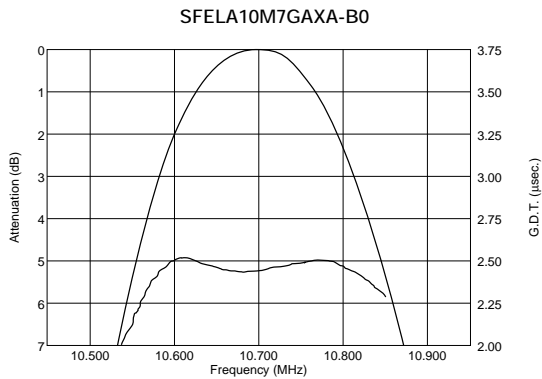
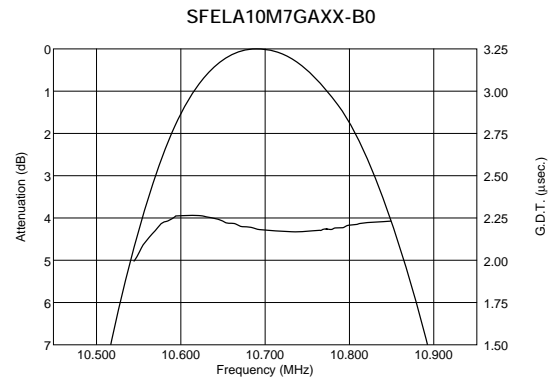
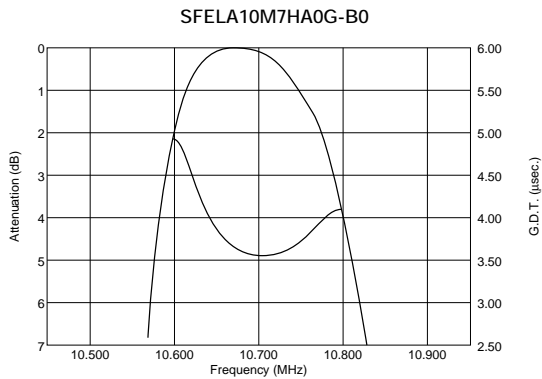
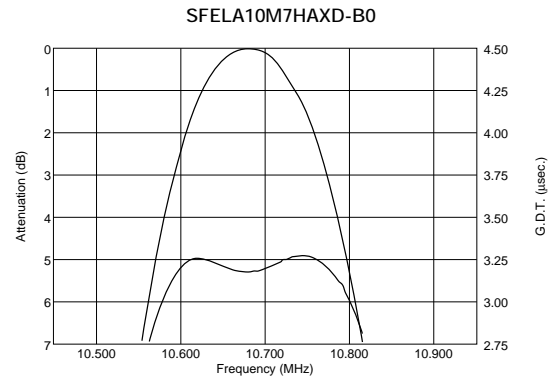
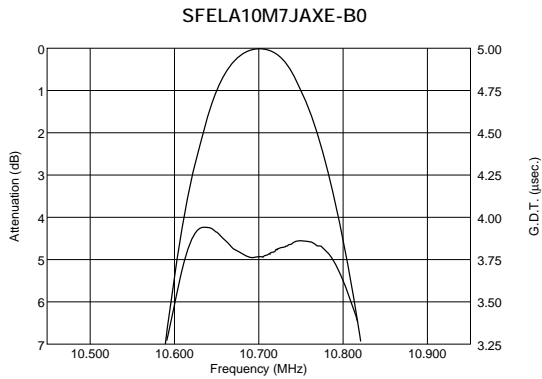

Continued on the following page. ↗

Continued from the preceding page.

Frequency Characteristics

SFELA10M7GALM-B0

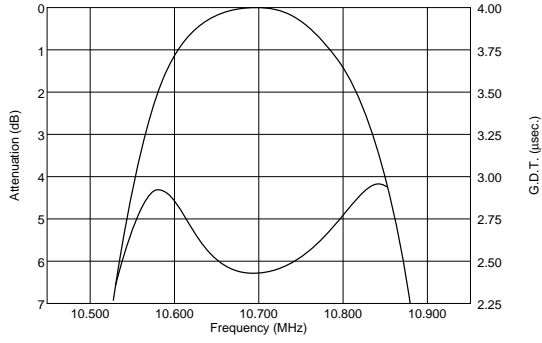

SFELA10M7GA0G-B0

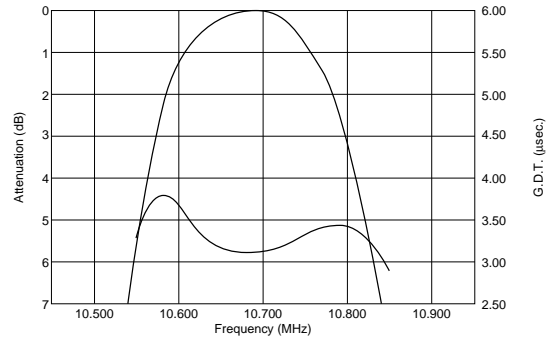

SFELA10M7FALL-B0

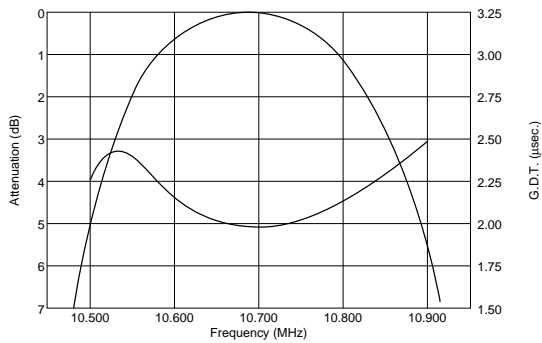

SFELA10M7FA0G-B0

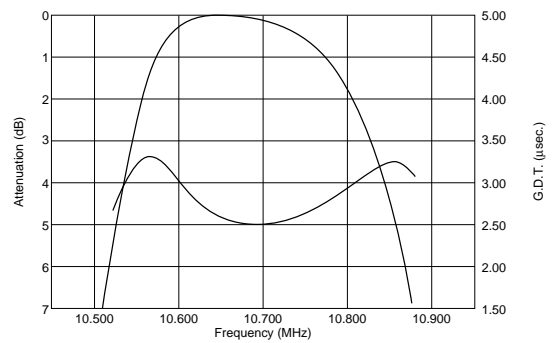

Frequency Characteristics (Spurious)

SFELA10M7JAXE-B0

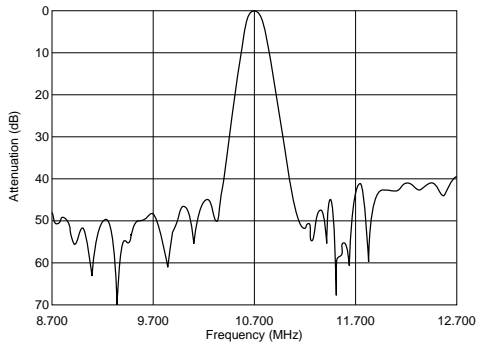

SFELA10M7HAXD-B0

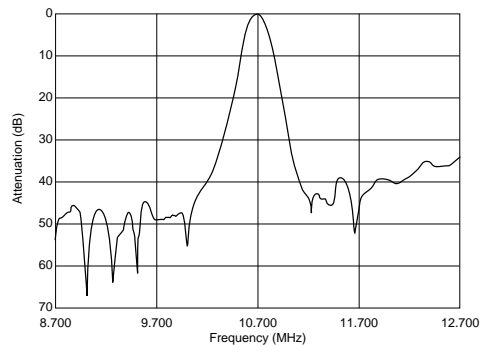

SFELA10M7HA0G-B0

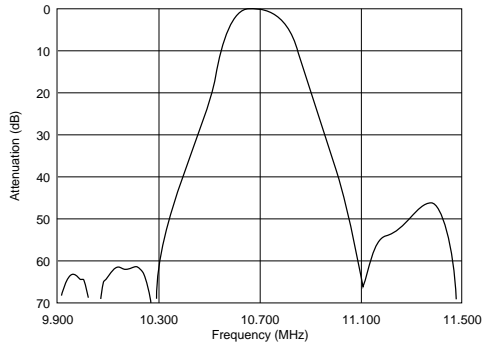

SFELA10M7GAXX-B0

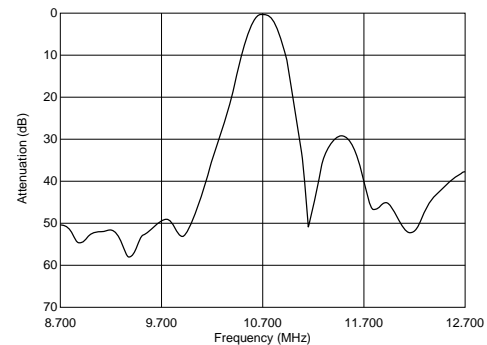

Continued on the following page.

Continued from the preceding page.

Frequency Characteristics (Spurious)

SFELA10M7GAXA-B0

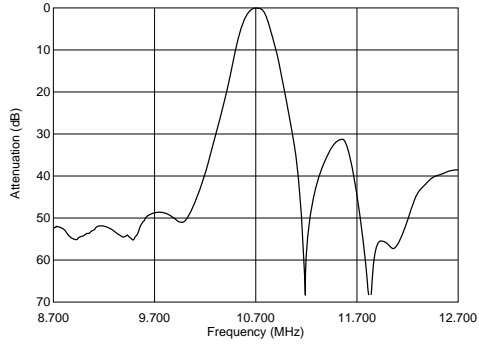

SFELA10M7GALP03-B0

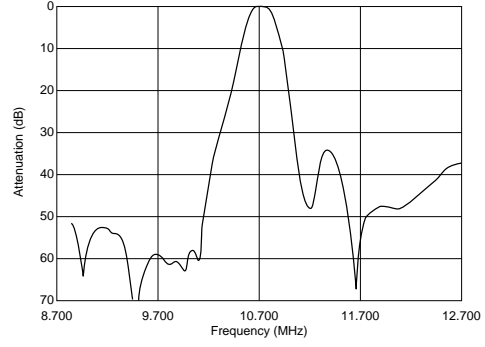

SFELA10M7GALM-B0

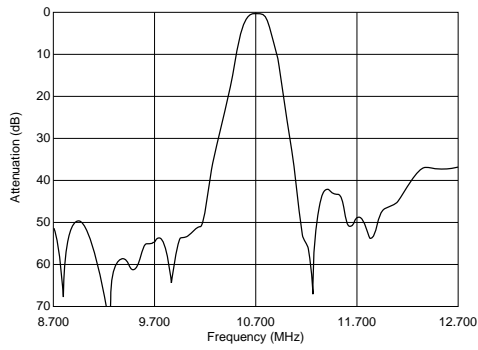

SFELA10M7GA0G-B0

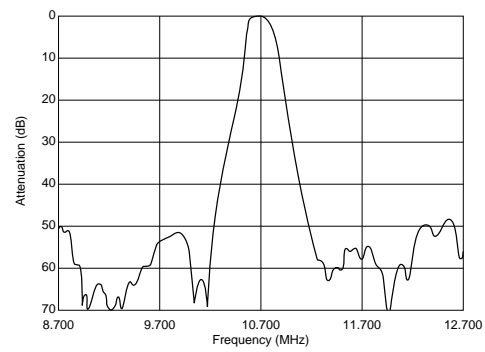

SFELA10M7FALL-B0

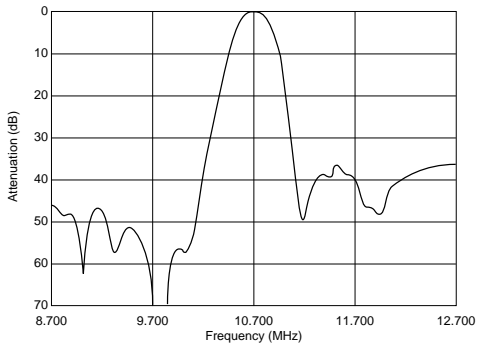

SFELA10M7FA0G-B0

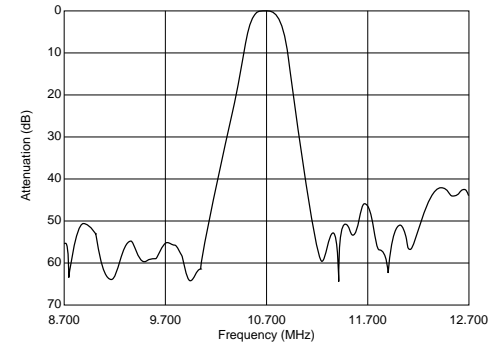

CERAFIL[®] (Filters/Traps/Discriminators) for Audio/Visual Equipment



CERAFIL[®] 10.7MHz High Selectivity Type SFTLA Series

SFTLA10M7 series for FM-receivers are monolithic type ceramic filters which use the thickness expander mode of the piezoelectric ceramic.

■ Features

1. It has an excellent shape factor, and it is possible to obtain 1.5 times more excellent selectivity than SFELA10M7 series (by detuning +300 or 400kHz).
2. Good performance of spurious suppression
3. Having the same terminal pitch as the SFELA10M7 series, it easily replaces that series.
4. By replacing two SFELA10M7 series filters with one SFTLA10M7 filter, more compact sets can be made.
5. Well-suited for 1-chip ICs

11



SFTLA10M7HA00-B0

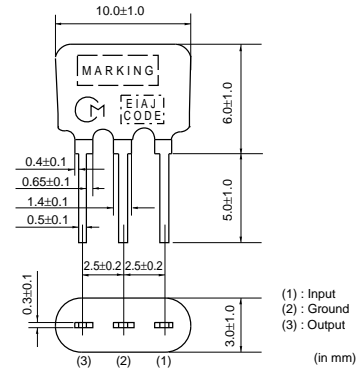

SFTLA10M7GA00-B0

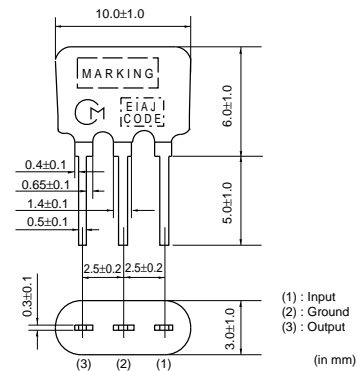

SFTLA10M7FA00-B0

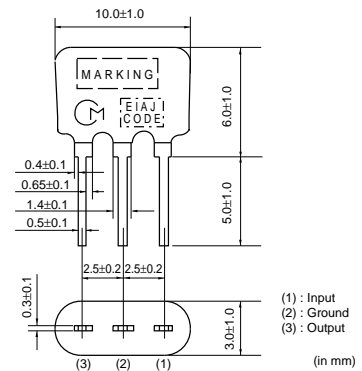

Part Number	Center Frequency (fo) (MHz)	3dB Bandwidth (kHz)	Attenuation (kHz)	Insertion Loss (dB)	Spurious Attenuation (dB)	Input/Output Impedance (ohm)
SFTLA10M7HA00-B0	10.700 ±30kHz	180 ±40kHz	510 max.	5.5 ±2.5dB	50 min.	330
SFTLA10M7GA00-B0	10.700 ±30kHz	230 ±40kHz	650 max.	6.0 ±2.0dB	50 min.	330
SFTLA10M7FA00-B0	10.700 ±30kHz	280 ±50kHz	700 max.	6.0 ±2.0dB	50 min.	330

Attenuation Bandwidth : at 40dB loss point Area of Spurious Attenuation : [within 9MHz to 12MHz]

Insertion Loss: at minimum loss point

Center frequency (fo) defined by the center of 3dB bandwidth.

(fn) means nominal center frequency.

The order quantity should be an integral multiple of the "Minimum Quantity" shown in the package page.

Standard Center Frequency Rank Code

CODE	30kHz Step	25kHz Step	Color Code
D	10.64MHz±30kHz	10.650MHz±25kHz	Black
B	10.67MHz±30kHz	10.675MHz±25kHz	Blue
A	10.70MHz±30kHz	10.700MHz±25kHz	Red
C	10.73MHz±30kHz	10.725MHz±25kHz	Orange
E	10.76MHz±30kHz	10.750MHz±25kHz	White
Z	Combination A,B,C,D,E		
M	Combination A,B,C		

Test Circuit

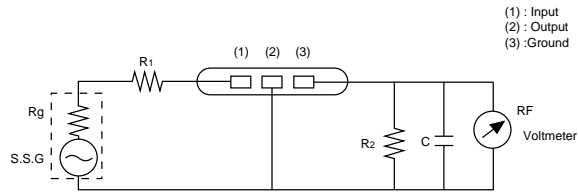

$R_g + R_1 = R_2 =$ Input and Output Impedance
 $C = 10\text{pF}$ (including stray capacitance and input capacitance of RF voltmeter.)

Frequency Characteristics

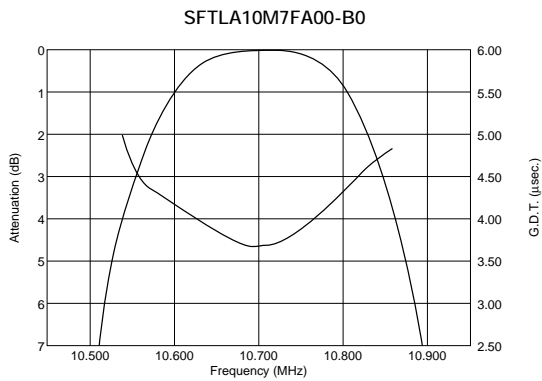
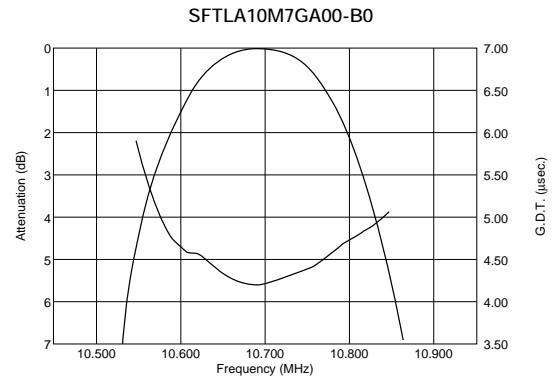
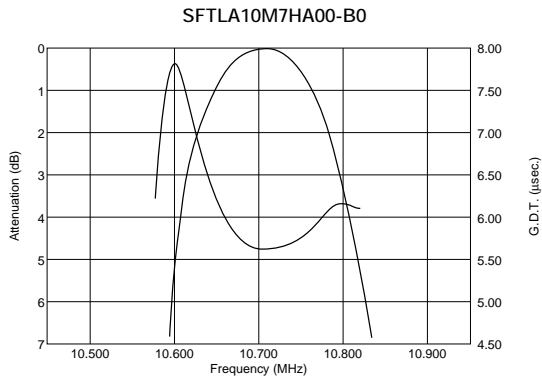

Frequency Characteristics (Spurious)

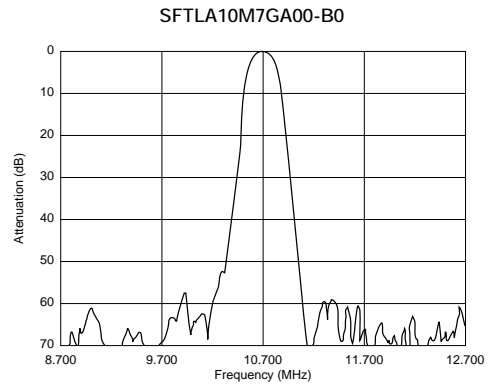
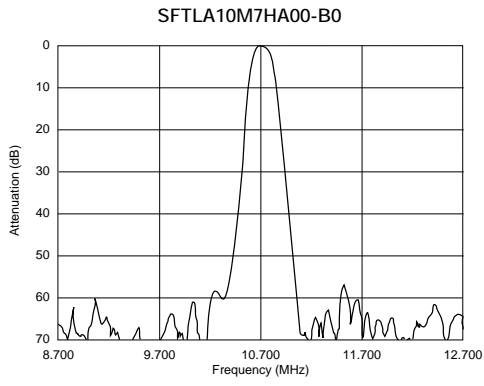

11

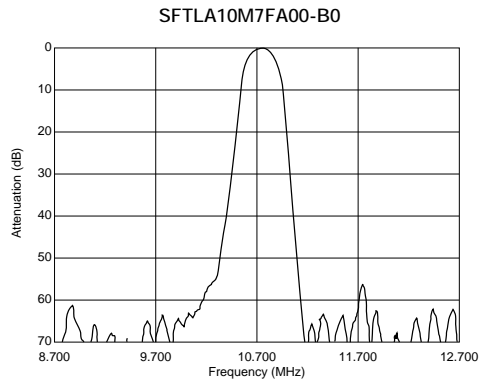

CERAFIL® 10.7MHz Related Data on Lead Type

Temperature Characteristics

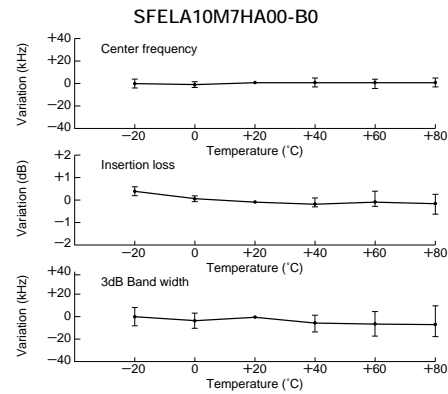
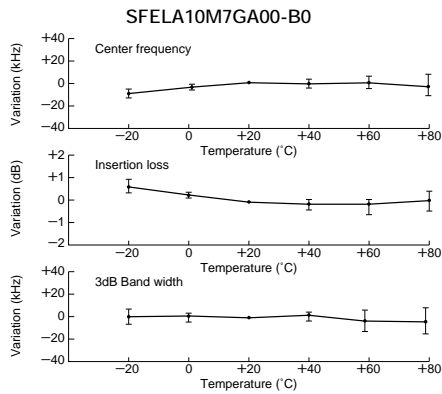

Matching Conditions

- When using ceramic filters, it is most important to match the input/output load to impedance 330 ohm (SFELA10M7DF00-B0 is 470 ohm and SFKLA10M7NL00-B0 is 600 ohm matching). Waveform symmetry is damaged when reactance is added to the input/output load.
- Two ceramic filters directly connected can be used for high selectivity. For reducing waveform variation, it is recommended to input a buffer AMP

- between ceramic filters.
- The SFELA10M7 and SFTLA10M7 series are of input/output symmetric structure so that in theory there is no input/output directionality. Actual circuits may use different input/output loading conditions (for example, mismatched impedance) or capacitance load. In such cases, the waveform will be a little changed by the direction of the input/output of the ceramic filters.

Loaded Resistance and Waveform (Rg+R1=330ohm)

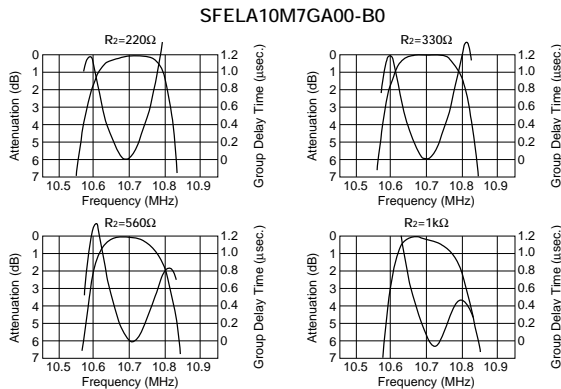

Loaded Capacitance and Waveform (Rg+R1=R2=330ohm)

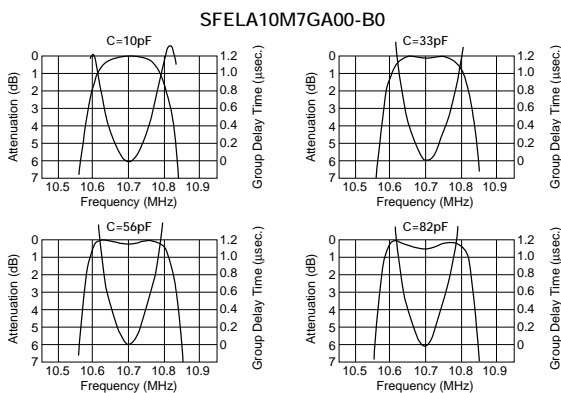

CERAFIL® (Filters/Traps/Discriminators) for Audio/Visual Equipment



CERAFIL® 4.5-6.5MHz Chip Type SFSKA Series

SMD ceramic filter SFSKA_CF is a small and thin SMD filter sealed with a metal cap.

Recommended for LCD-TV's, and small and thin tuners.

■ Features

1. High attenuation outside bandwidth
2. Small and thin package
3. Reflow-solderable

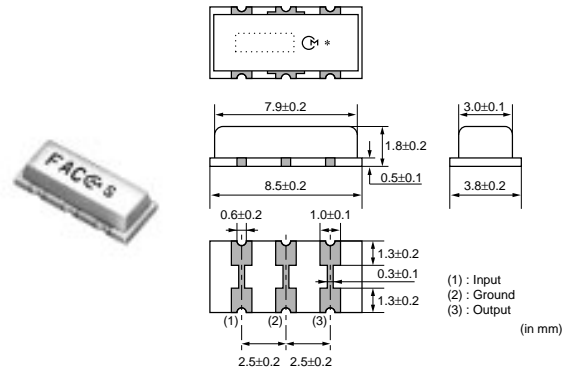

12

Part Number	Nominal Center Frequency (fn) (MHz)	3dB Bandwidth (kHz)	20dB Bandwidth (kHz)	Insertion Loss (dB)	Spurious Attenuation(1) (dB)	Spurious Attenuation(2) (dB)	Input/Output Impedance (ohm)
SFSKA4M50CF00-R1	4.500	fn±60 min.	600 max.	6.0 max.	20 min. [within 0 to fn]	15 min. [within fn to 7.0MHz]	1000

Insertion Loss: at minimum loss point

The order quantity should be an integral multiple of the "Minimum Quantity" shown in the package page.

■ Standard Land Pattern Dimensions

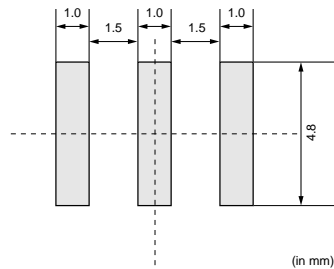

■ Test Circuit

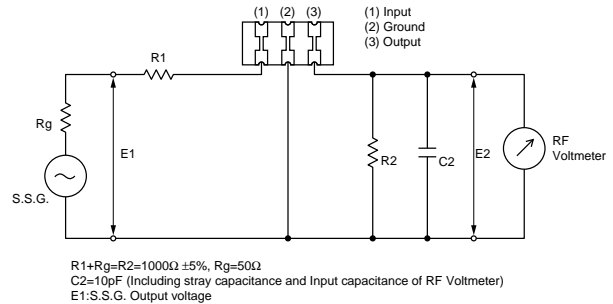

■ Frequency Characteristics

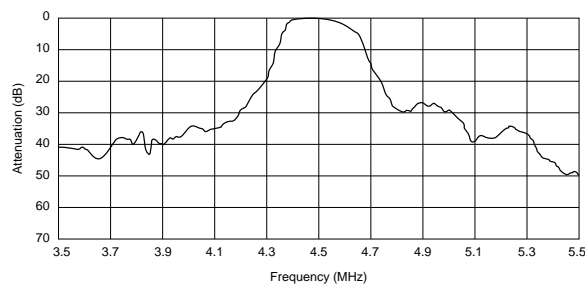

■ Frequency Characteristics (Spurious)

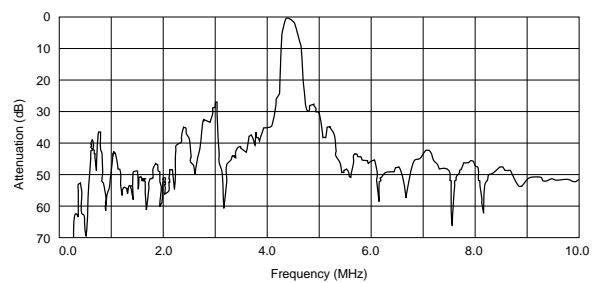

CERAFIL[®] (Filters/Traps/Discriminators) for Audio/Visual Equipment



CERAFIL[®] 4.5-6.5MHz Standard Lead Type SFSRA Series

As part of the environment protection activity, solder for terminal plating and terminal-element connection inside of ceramic filter SFSRA series contains no lead (Pb).

This series also features thickness shear mode same as SFSRH series (current type), which provides very low spurious response within video signal band.

■ Features

1. Excellent spurious suppression characteristics within video signal band.
2. Available 4 pass bandwidth variation to meet various requests.
3. Low profile (H=7.0mm max.)
4. Lead dimension: Improved mounting reliability (cut & clinch) due to round terminal.

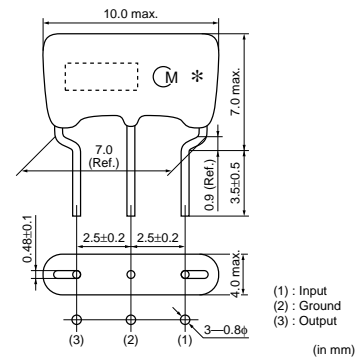

Part Number	Nominal Center Frequency (fn) (MHz)	3dB Bandwidth (kHz)	20dB Bandwidth (kHz)	Insertion Loss (dB)	Spurious Attenuation(1) (dB)	Spurious Attenuation(2) (dB)	Input/Output Impedance (ohm)
SFSRA4M50CF00-B0	4.500	fn±60 min.	600 max.	6.0 max.	30 min. [within 0 to fn]	20 min. [within fn to 7.0MHz]	1000
SFSRA4M50DF00-B0	4.500	fn±70 min.	750 max.	6.0 max.	30 min. [within 0 to fn]	20 min. [within fn to 7.0MHz]	1000
SFSRA4M50EF00-B0	4.500	fn±125 min.	850 max.	6.0 max.	25 min. [within 0 to fn]	18 min. [within fn to 7.0MHz]	1000
SFSRA5M50BF00-B0	5.500	fn±50 min.	400 max.	8.0 max.	30 min. [within 0 to fn]	20 min. [within fn to 7.5MHz]	600
SFSRA5M50CF00-B0	5.500	fn±60 min.	600 max.	6.0 max.	30 min. [within 0 to fn]	20 min. [within fn to 7.5MHz]	600
SFSRA5M50DF00-B0	5.500	fn±80 min.	750 max.	6.0 max.	30 min. [within 0 to fn]	20 min. [within fn to 7.5MHz]	600
SFSRA5M74BF00-B0	5.742	fn±50 min.	400 max.	8.0 max.	30 min. [within 0 to fn]	20 min. [within fn to 7.5MHz]	600
SFSRA5M74CF00-B0	5.742	fn±60 min.	600 max.	6.0 max.	30 min. [within 0 to fn]	20 min. [within fn to 7.5MHz]	600
SFSRA6M00CF00-B0	6.000	fn±60 min.	600 max.	6.0 max.	30 min. [within 0 to fn]	20 min. [within fn to 8.0MHz]	470
SFSRA6M00DF00-B0	6.000	fn±80 min.	750 max.	6.0 max.	30 min. [within 0 to fn]	20 min. [within fn to 8.0MHz]	470
SFSRA6M50CF00-B0	6.500	fn±70 min.	650 max.	6.0 max.	30 min. [within 0 to fn]	20 min. [within fn to 8.5MHz]	470
SFSRA6M50DF00-B0	6.500	fn±80 min.	800 max.	6.0 max.	30 min. [within 0 to fn]	20 min. [within fn to 8.5MHz]	470

Insertion Loss: at minimum loss point

The order quantity should be an integral multiple of the "Minimum Quantity" shown in the package page.

■ Test Circuit

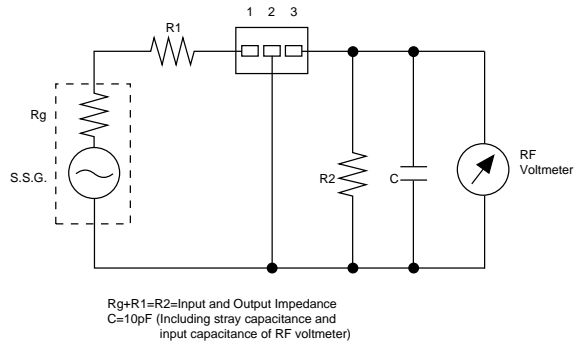

■ Frequency Characteristics

SFSRA4M50CF00-B0

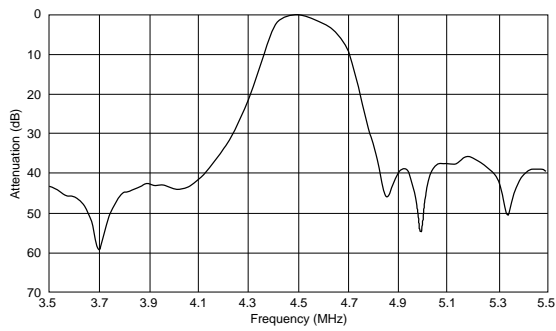

SFSRA4M50DF00-B0

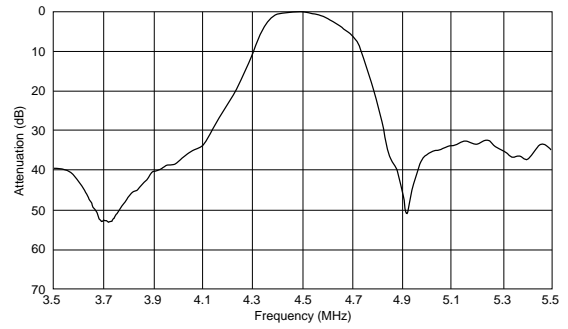

SFSRA4M50EF00-B0

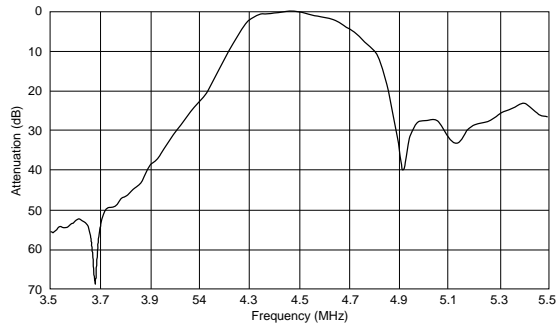

SFSRA5M50BF00-B0

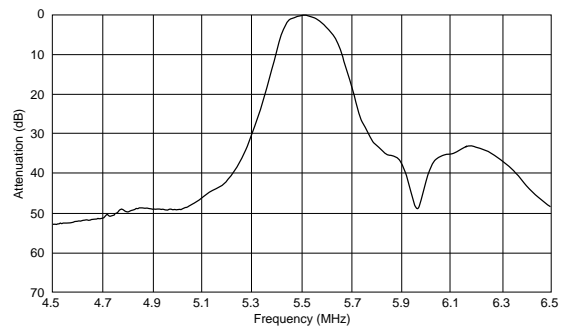

SFSRA5M50CF00-B0

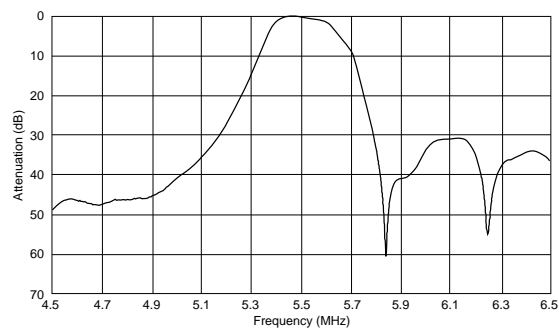

SFSRA5M50DF00-B0

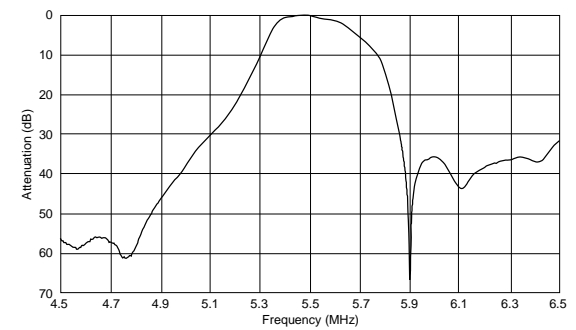

13

↳ Continued from the preceding page.

■ Frequency Characteristics

SFSRA5M74BF00-B0

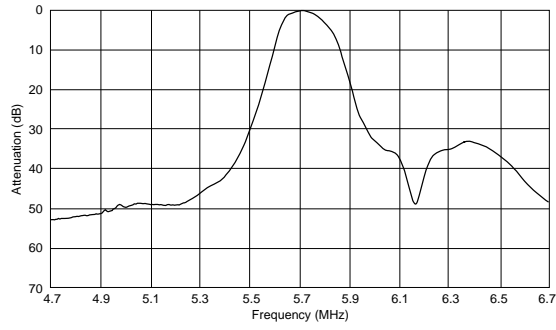

SFSRA5M74CF00-B0

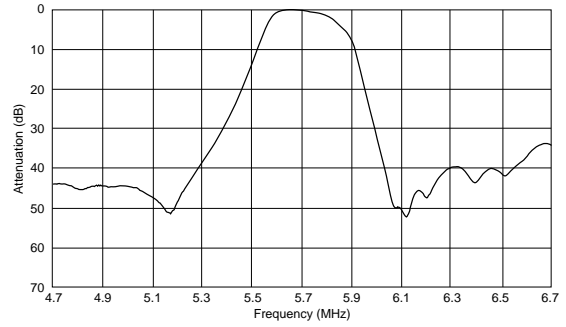

SFSRA6M00CF00-B0

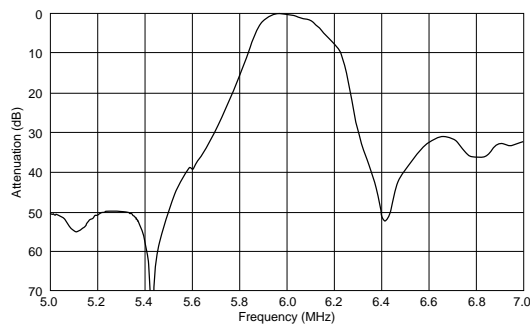

SFSRA6M00DF00-B0

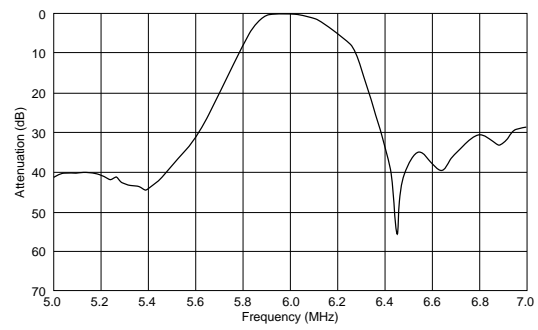

SFSRA6M50CF00-B0

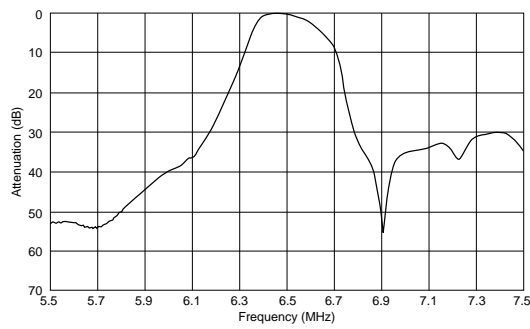

SFSRA6M50DF00-B0

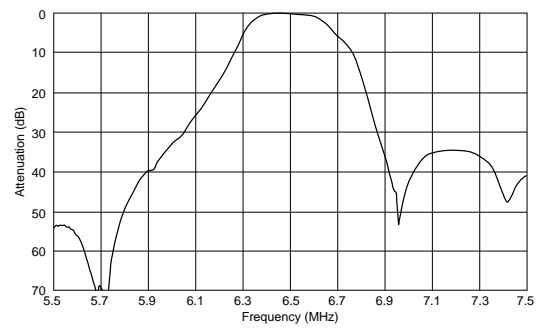

■ Frequency Characteristics (Spurious)

SFSRA4M50CF00-B0

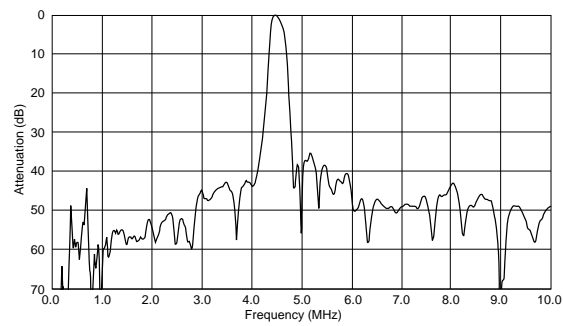

SFSRA4M50DF00-B0

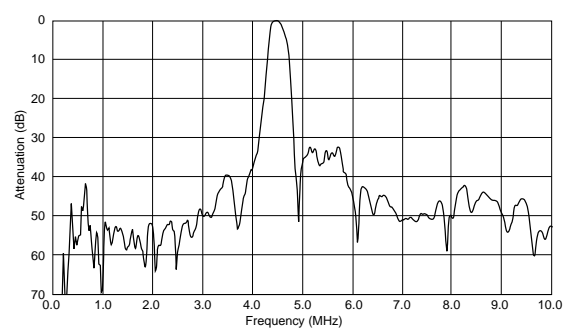

Continued from the preceding page.

Frequency Characteristics (Spurious)

SFSRA4M50EF00-B0

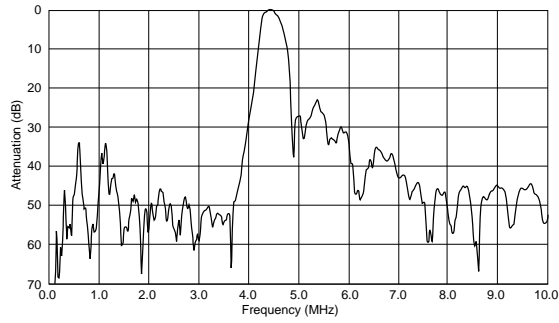

SFSRA5M50BF00-B0

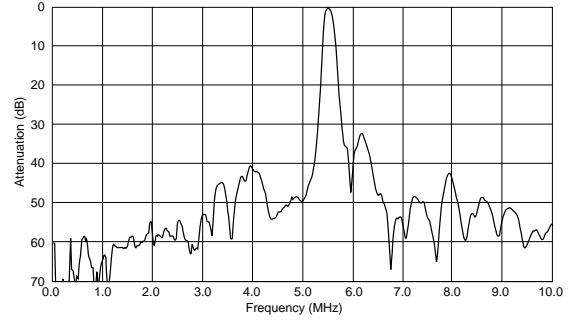

SFSRA5M50CF00-B0

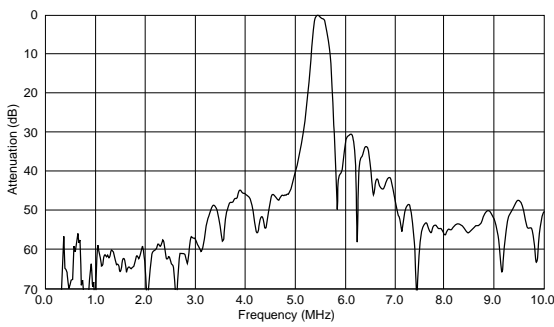

SFSRA5M50DF00-B0

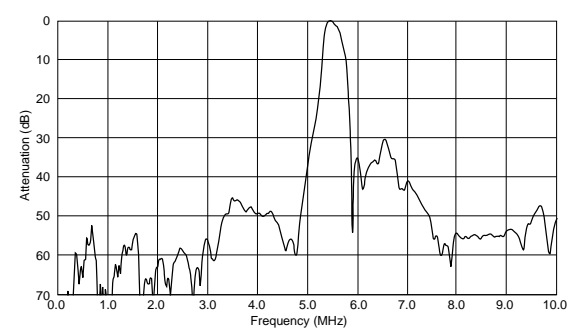

SFSRA5M74BF00-B0

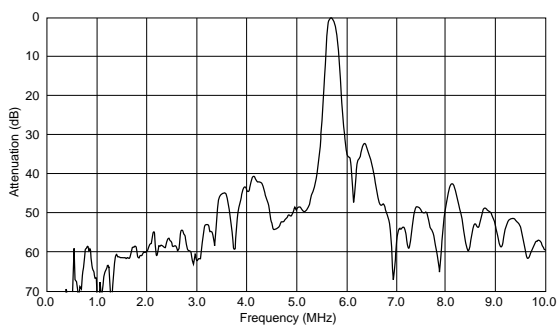

SFSRA5M74CF00-B0

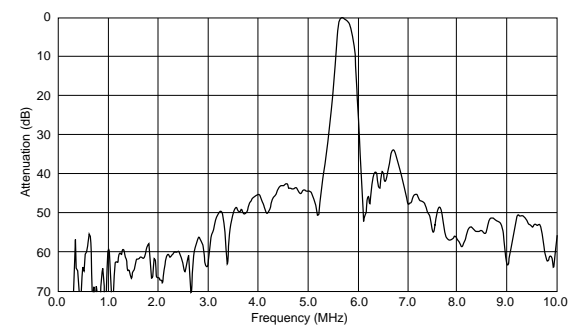

SFSRA6M00CF00-B0

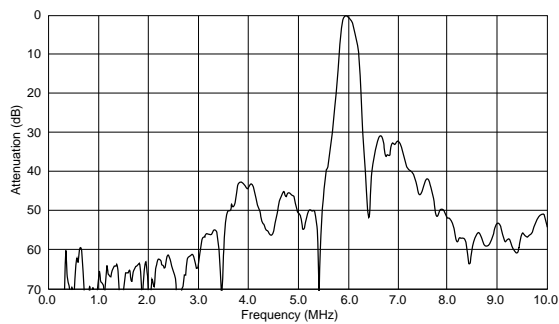

SFSRA6M00DF00-B0

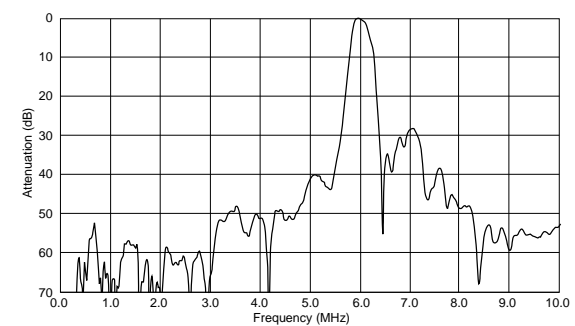

Continued from the preceding page.

Frequency Characteristics (Spurious)

SFSRA6M50CF00-B0

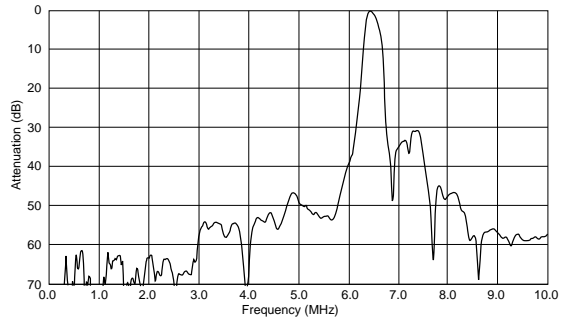

SFSRA6M50DF00-B0

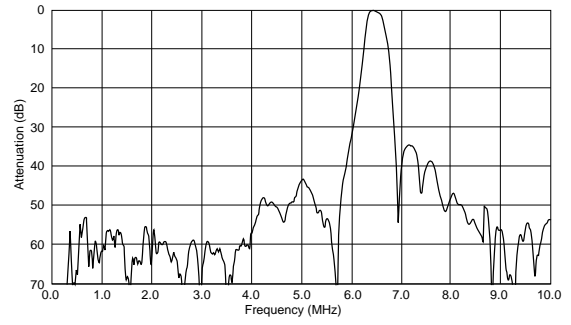

CERAFIL® (Filters/Traps/Discriminators) for Audio/Visual Equipment



CERAFIL® 3.5-6.5MHz Low Profile Type SFSRL Series

SFSRL series are the Low-profile type of standard SFSRA series.

■ Features

1. Installed height is 6.0mm, making it well suited for compact, thin sets.
2. Electrical char. and performance are the same as those of SFSRA series.
3. 2 types, narrow and middle bandwidth, are prepared.

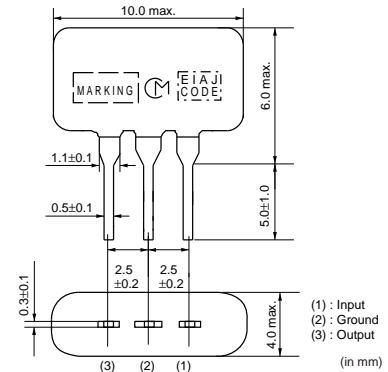

14

Part Number	Nominal Center Frequency (fn) (MHz)	3dB Bandwidth (kHz)	20dB Bandwidth (kHz)	Insertion Loss (dB)	Spurious Attenuation(1) (dB)	Spurious Attenuation(2) (dB)	Input/Output Impedance (ohm)
SFSRL4M50CF00-B0	4.500	fn±60 min.	600 max.	6.0 max.	30 min. [within 0 to fn]	15 min. [within fn to 7.0MHz]	1000
SFSRL4M50DF00-B0	4.500	fn±70 min.	750 max.	6.0 max.	30 min. [within 0 to fn]	15 min. [within fn to 5.7MHz]	1000
SFSRL5M50CF00-B0	5.500	fn±60 min.	600 max.	6.0 max.	30 min. [within 0 to fn]	15 min. [within fn to 7.0MHz]	600
SFSRL5M50DF00-B0	5.500	fn±80 min.	750 max.	6.0 max.	30 min. [within 0 to fn]	15 min. [within fn to 7.0MHz]	600
SFSRL6M00CF00-B0	6.000	fn±60 min.	600 max.	6.0 max.	30 min. [within 0 to fn]	15 min. [within fn to 7.5MHz]	470
SFSRL6M00DF00-B0	6.000	fn±80 min.	750 max.	6.0 max.	30 min. [within 0 to fn]	15 min. [within fn to 7.5MHz]	470
SFSRL6M50CF00-B0	6.500	fn±70 min.	650 max.	6.0 max.	30 min. [within 0 to fn]	15 min. [within fn to 8.5MHz]	470
SFSRL6M50DF00-B0	6.500	fn±80 min.	800 max.	6.0 max.	30 min. [within 0 to fn]	15 min. [within fn to 8.0MHz]	470

Insertion Loss: at minimum loss point
 The order quantity should be an integral multiple of the "Minimum Quantity" shown in the package page.

■ Test Circuit

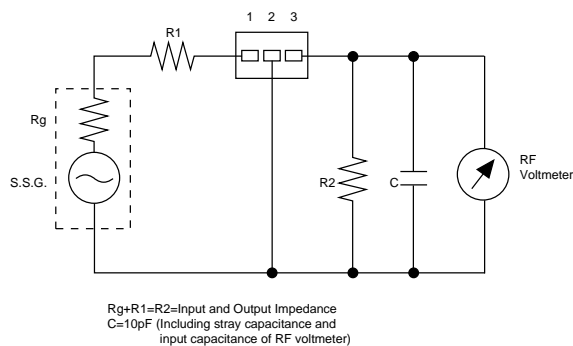

Frequency Characteristics

SFSRL4M50CF00-B0

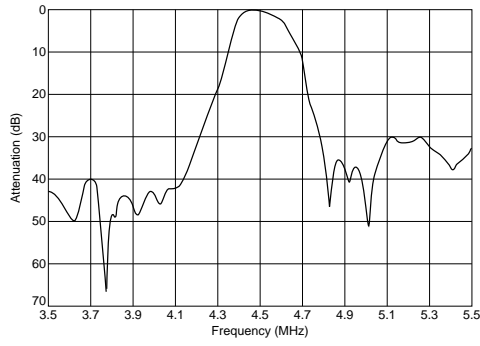

SFSRL4M50DF00-B0

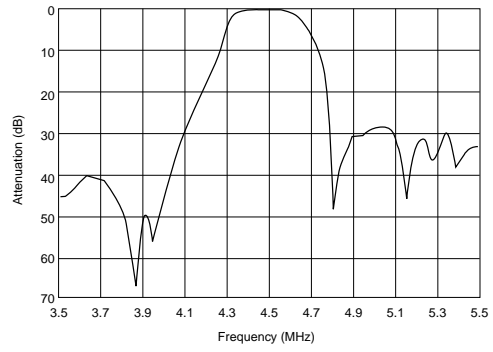

SFSRL5M50CF00-B0

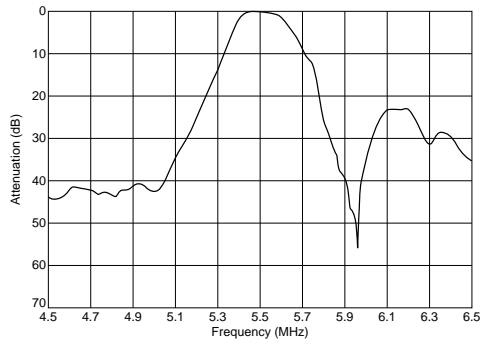

SFSRL5M50DF00-B0

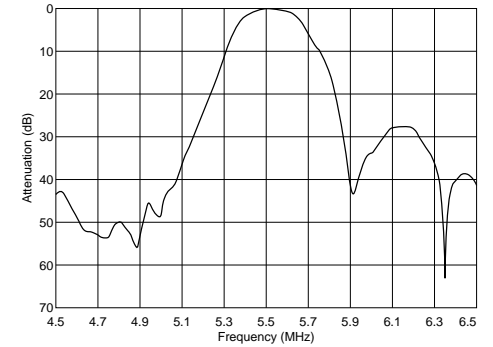

SFSRL6M00CF00-B0

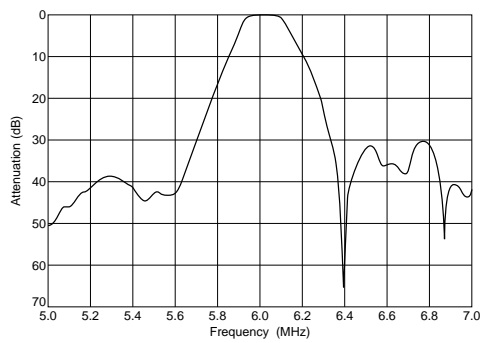

SFSRL6M00DF00-B0

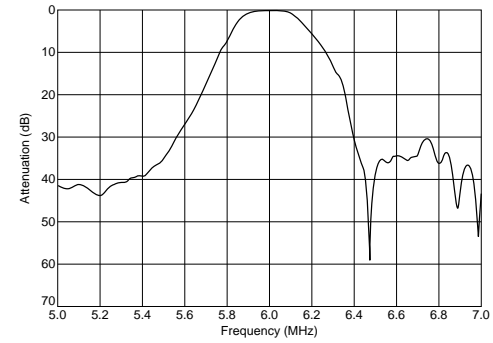

SFSRL6M50CF00-B0

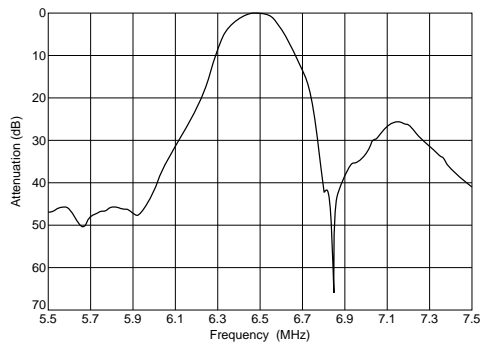

SFSRL6M50DF00-B0

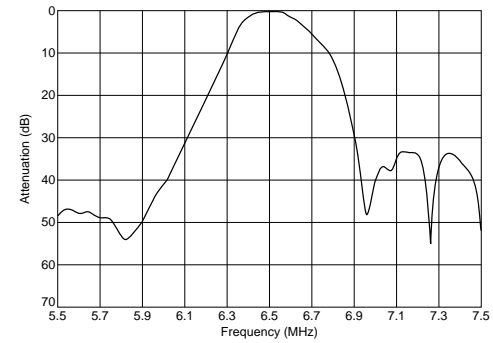

Continued from the preceding page.

Frequency Characteristics (Spurious)

SFSRL4M50CF00-B0

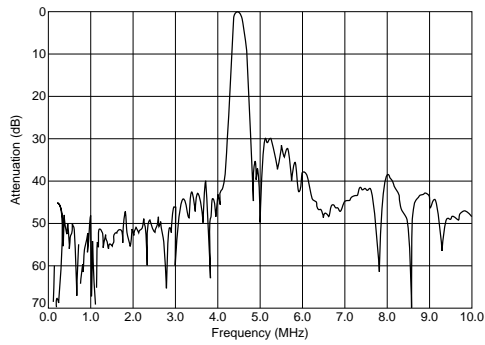

SFSRL4M50DF00-B0

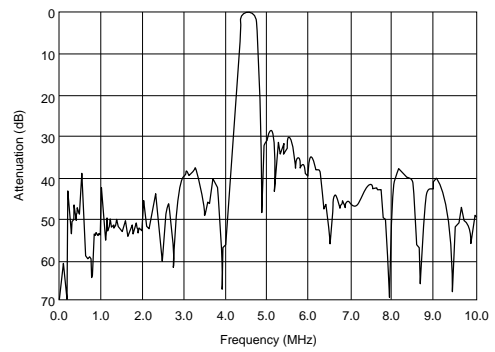

SFSRL5M50CF00-B0

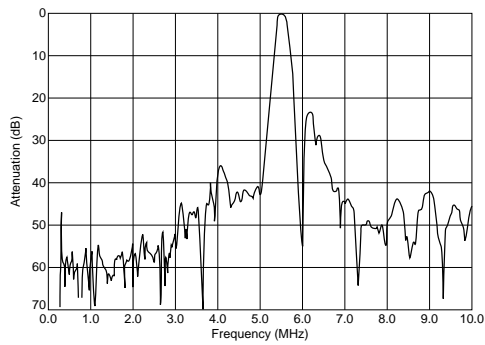

SFSRL5M50DF00-B0

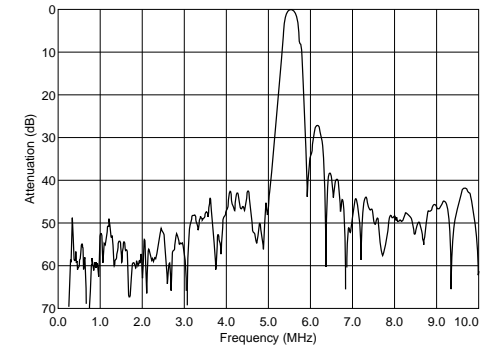

SFSRL6M00CF00-B0

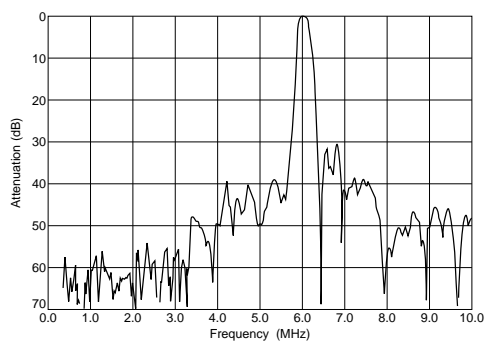

SFSRL6M00DF00-B0

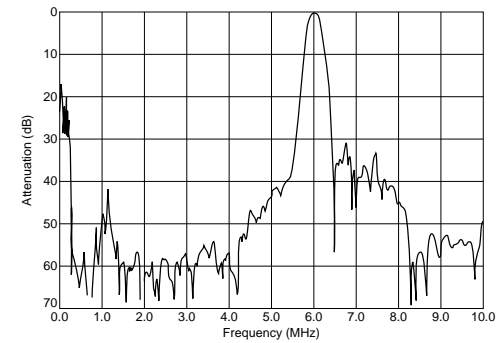

SFSRL6M50CF00-B0

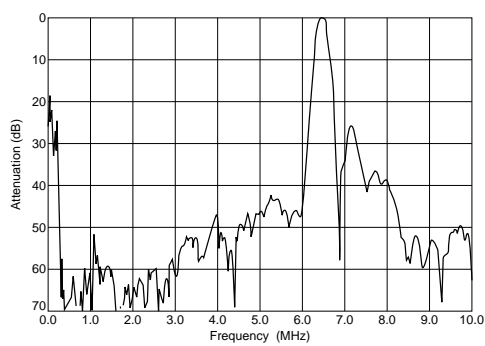

SFSRL6M50DF00-B0

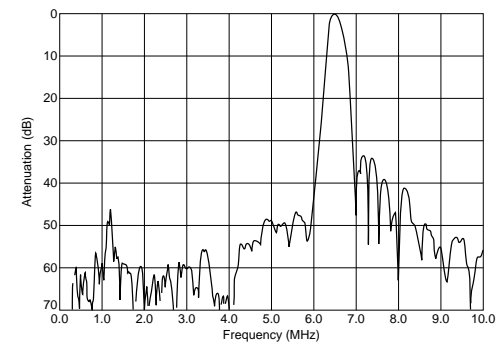

CERAFIL® (Filters/Traps/Discriminators) for Audio/Visual Equipment



CERAFIL® 3.5-6.5MHz for Chroma Signal SFSRA/L Series

Chroma signals frequency conversion process is involved in VCRs video signal processing circuit. These SFSRA/SFSRH/SFSRL series are suitable for B.P.F.

■ Features

1. Frequency adjustment free.
2. Responsible for VHS. 8mm VCR system.



SFSRA Series

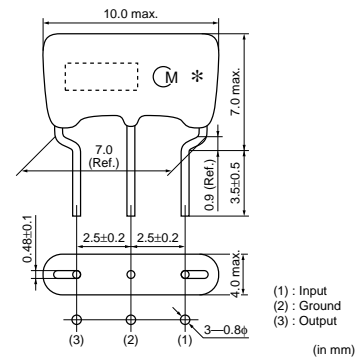

SFSRL Series

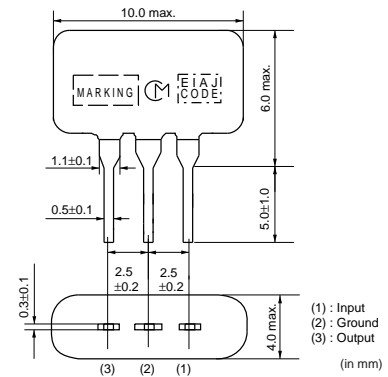

Part Number	Nominal Center Frequency (fn) (MHz)	3dB Bandwidth (kHz)	20dB Bandwidth (kHz)	Insertion Loss (dB)	Spurious Attenuation(1) (dB)	Spurious Attenuation(2) (dB)	Input/Output Impedance (ohm)
SFSRA4M43CF00-B0	4.430	fn±60 min.	600 max.	6.0 max.	30 min. [within 0 to fn]	20 min. [within fn to 7.0MHz]	1000
SFSRL4M32DF00-B0	4.320	fn±70 min.	750 max.	6.0 max.	30 min. [within 0 to fn]	15 min. [within fn to 5.5MHz]	1000
SFSRL5M17DF00-B0	5.170	fn±70 min.	750 max.	7.5 max.	30 min. [within 0 to fn]	15 min. [within fn to 7.0MHz]	600

Insertion Loss: at minimum loss point
The order quantity should be an integral multiple of the "Minimum Quantity" shown in the package page.

■ Test Circuit

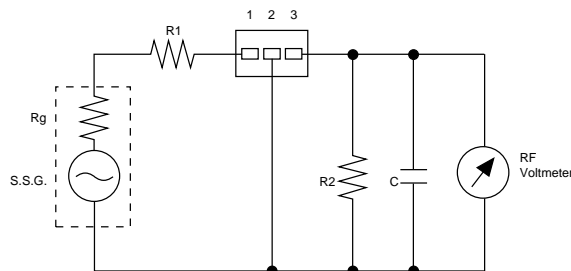

Rg+R1=R2=Input and Output Impedance
C=10pF (Including stray capacitance and input capacitance of RF voltmeter)

Frequency Characteristics

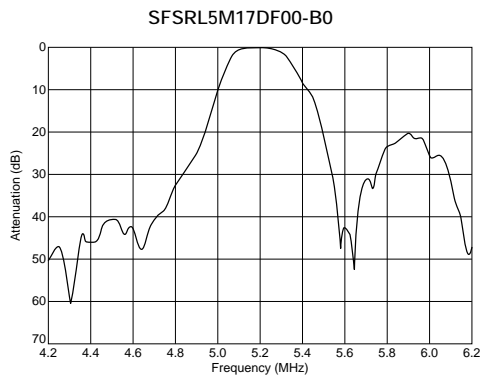
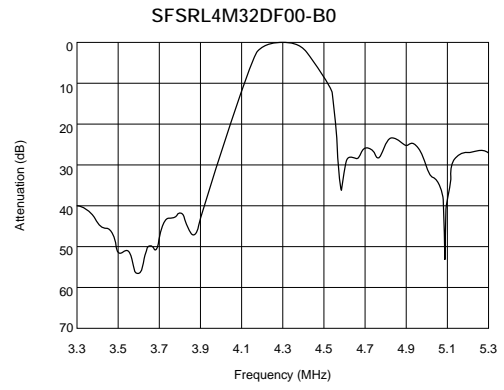
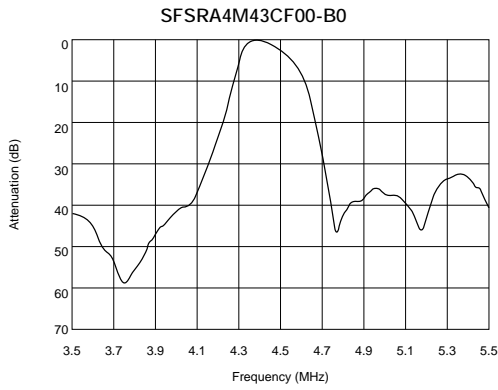

15

Frequency Characteristics (Spurious)

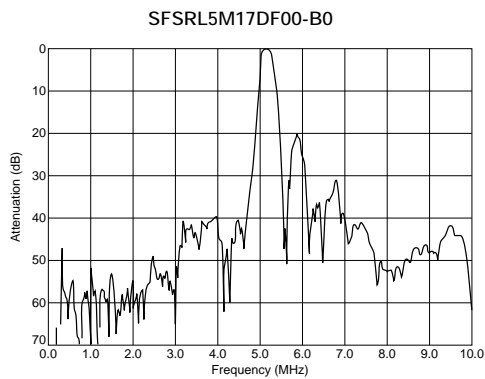
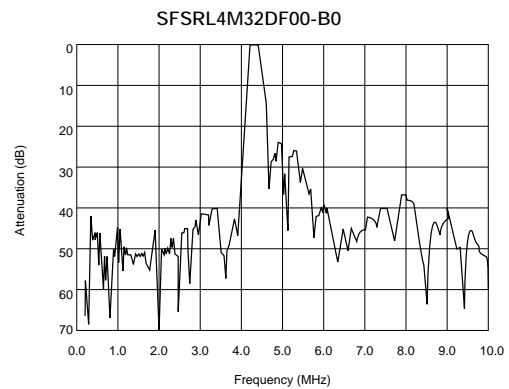
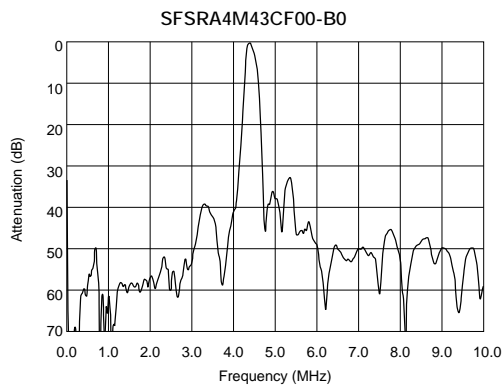

CERAFIL[®] (Filters/Traps/Discriminators) for Audio/Visual Equipment



CERAFIL[®] 455kHz Chip Type PFWCC Series

PFWCC series for AM use is one of the most recommendable intermediate filters, having such distinctive features as high selectivity, high stability, and adjustment-free operation. Additionally its easy matching with IC helps create an easy circuit design. This is the most recommendable for portable radio with small package. Especially, reflowable with SMD package.

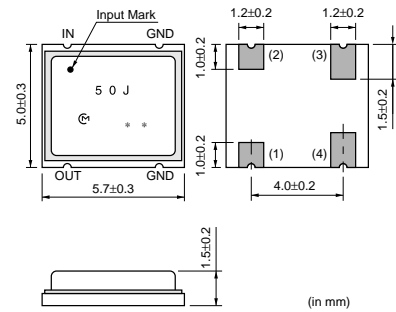

■ Features

1. Center frequency range between 450 and 470 kHz are available standard tolerance of ± 2 kHz.
2. For frequency synthesizers, center frequencies of 450, 459 and 468 kHz are available standard tolerance of ± 1 kHz.

Part Number	Center Frequency (fo) (kHz)	3dB Bandwidth (kHz)	Selectivity (+) (dB)	Selectivity (-) (dB)	Insertion Loss (dB)	Input/Output Impedance (ohm)	Element
PFWCC450KS2A-R0	450 \pm 2.0kHz	5.5 \pm 1.5kHz	17 min. [fo+9kHz]	17 min. [fo-9kHz]	6.0 max.	3000	2

Insertion Loss: at minimum loss point

Center frequency (fo) is defined by the center of 3dB bandwidth.

For safety purposes, connect the output of filters to the IF amplifier through a D.C. blocking capacitor. Avoid applying a direct current to the output of ceramic filters.

The order quantity should be an integral multiple of the "Minimum Quantity" shown in the package page.

■ Standard Land Pattern Dimensions

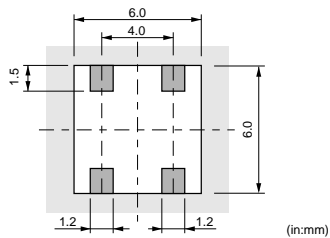

The solder resist should be printed except for the land pattern on the P.C.B..

The material of P.C.B. is the epoxy resin of glass fabric base (t=0.8mm)

■ Recommended IFT

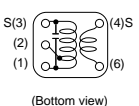
Item \ Type	7×7mm IFT			5×5mm IFT		
Winding Specification	(1)–(2)	(2)–(3)	(4)–(6)	(1)–(2)	(2)–(3)	(4)–(6)
 S(3) (2) (1) (4)S (6) (Bottom view)	85T	67T	23T	84T	98T	33T
No load Q_u	90			65		
Tuning Capacitance	180pF			180pF		

* Matching of CERAFIL®PFWLA series with IFT is decided by the IFT secondary side impedance, |Z₂|. Set the |Z₂| at about 4.2kΩ.

■ Test Circuit (CERAFIL® Only)

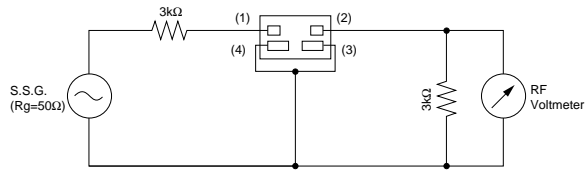

■ Test Circuit (CERAFIL® with IFT)

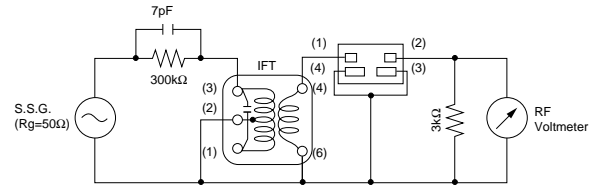

16

■ Frequency Characteristics

IFT+PFWCC450KS2A-R0

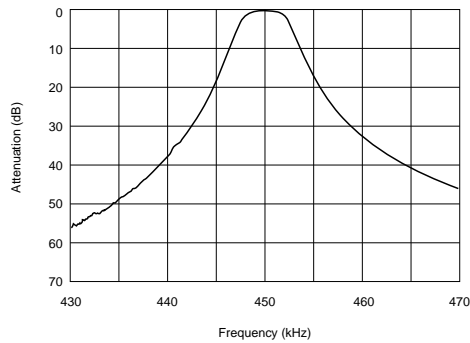

■ Frequency Characteristics (Spurious)

IFT+PFWCC450KS2A-R0

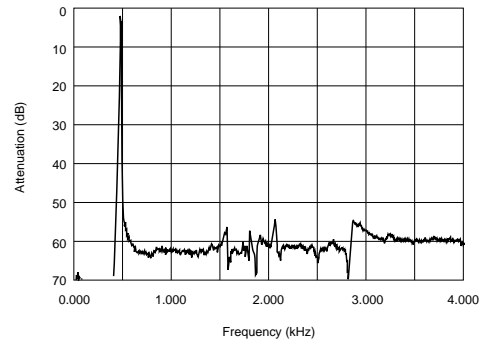

CERAFIL[®] (Filters/Traps/Discriminators) for Audio/Visual Equipment



CERAFIL[®] 455kHz Chip Type SFPCA Series

SFPCA series for AM use is one of the most recommendable intermediate filters, having such distinctive features as high selectivity, high stability and adjustment-free operation. Additionally its easy matching with IC helps create an easy circuit design.

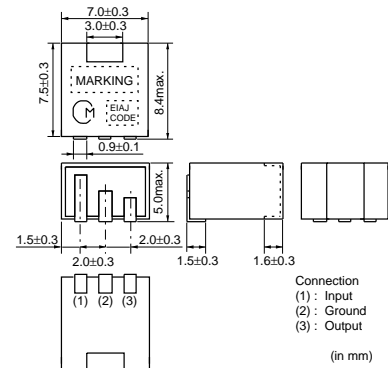

■ Features

1. The filters are mountable by automatic placers and can be reflow soldered and withstand washing.
2. The filters are wide bandwidth and high selectivity. So they are suitable for car radio and multi band radio.

Part Number	Center Frequency (fo) (kHz)	6dB Bandwidth (kHz)	Selectivity (+) (dB)	Selectivity (-) (dB)	Insertion Loss (dB)	Input/Output Impedance (ohm)	Element
SFPCA450KH1A-R1	450 ±1.0kHz	fn±3.0 min.	40 min. [fn+9kHz]	40 min. [fn-9kHz]	6.0 max.	2000	4
SFPCA450KG1A-R1	450 ±1.0kHz	fn±4.5 min.	40 min. [fn+10kHz]	40 min. [fn-10kHz]	6.0 max.	1500	4
SFPCA450KF4A-R1	450 ±1.5kHz	fn±6.0 min.	40 min. [fn+12.5kHz]	40 min. [fn-12.5kHz]	6.0 max.	1500	4

Insertion Loss: at minimum loss point

Center frequency (fo) is defined by the center of 6dB bandwidth.

(fn) means nominal center frequency (450kHz).

For safety purposes, connect the output of filters to the IF amplifier through a D.C. blocking capacitor. Avoid applying a direct current to the output of ceramic filters.

The order quantity should be an integral multiple of the "Minimum Quantity" shown in the package page.

■ Standard Land Pattern Dimensions

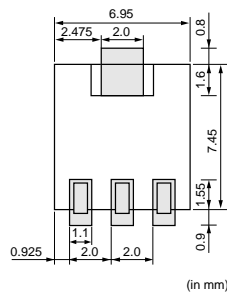

Recommended IFT

Item	Type	SFPCA		
Winding Specification		(1)—(2)	(2)—(3)	(4)—(6)
S(3) (2) (1)		60T	125T	28T
	(Bottom view)			
No load Qu		40		
Tuning Capacitance		180pF		

• Matching of CERAFIL® SFPCA series with IFT is decided by the Qu of IFT and IFT secondary side impedance, [Z2]. Set the Qu at about 40 because a Qu value which is too high (e.g., 90) may produce ripple in the waveform. It is recommended to match the impedance of [Z2] with that of the CERAFIL®.

Test Circuit

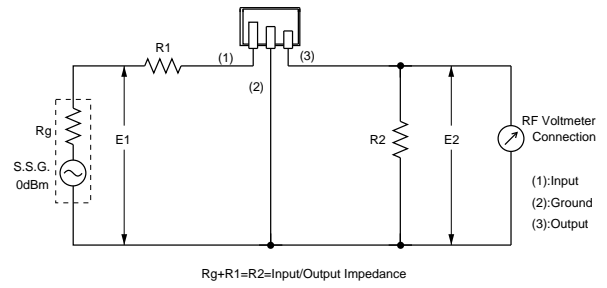

Frequency Characteristics

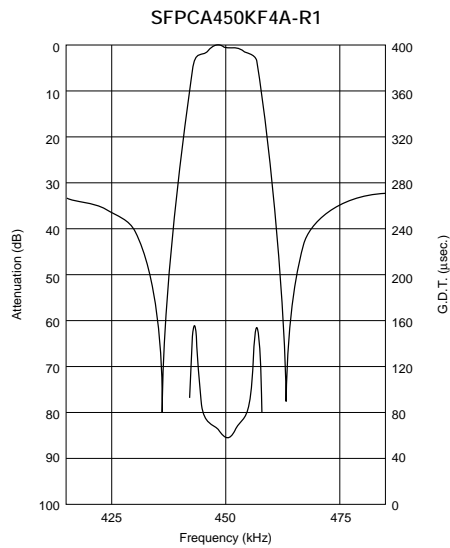
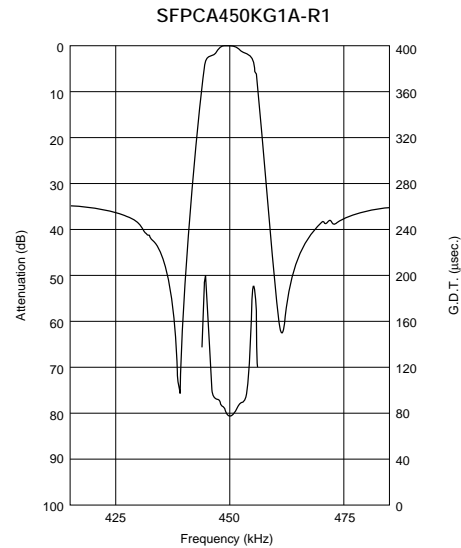
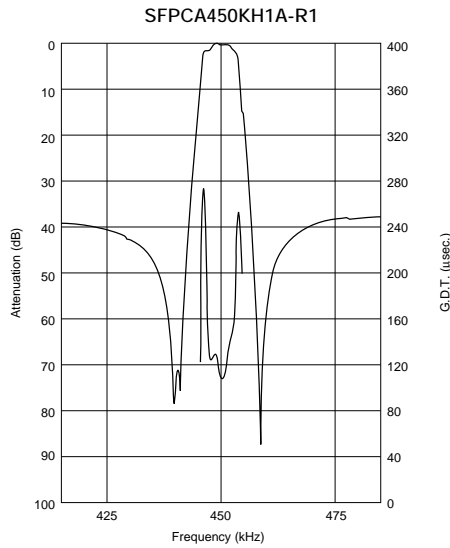

CERAFIL® (Filters/Traps/Discriminators) for Audio/Visual Equipment



CERAFIL® 455kHz SFULA/SFZLA Series

SFULA/SFZLA series for AM use is one of the most recommendable intermediate filters, having such distinctive features as high selectivity, high stability, and adjustment-free operation. Additionally its easy matching with IC helps create an easy circuit design.

■ Features

1. Center frequency range between 450 to 470 kHz are available standard tolerance of ± 2 kHz.
2. For frequency synthesizers, center frequencies of 450, 459 and 468 kHz are available standard tolerance of ± 1 kHz.



SFULA Series

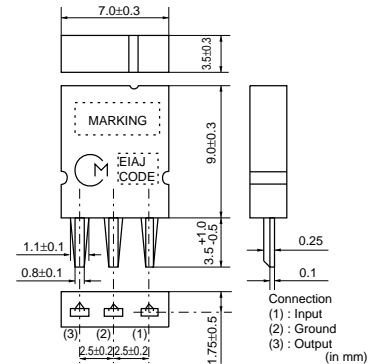

SFZLA Series

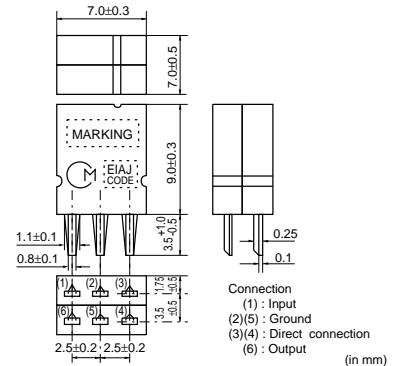

Part Number	Center Frequency (fo) (kHz)	3dB Bandwidth (kHz)	Selectivity (+) (dB)	Selectivity (-) (dB)	Insertion Loss (dB)	Input/Output Impedance (ohm)	Element
SFULA455KU2A-B0	455 ±2.0kHz	10.0 ±3.0kHz	4 min.[fo+10kHz]	6 min.[fo-10kHz]	5.0 max.	3000	1
SFULA455KU2B-B0	462 ±2.0kHz	10.0 ±3.0kHz	4 min.[fo+10kHz]	6 min.[fo-10kHz]	5.0 max.	3000	1
SFZLA455KN2A-B0	455.5 ±2.0kHz	4.0 ±1.0kHz	23 min.[fo+9kHz]	23 min.[fo-9kHz]	7.0 max.	3000	2
SFZLA455KS2A-B0	456 ±2.0kHz	5.5 ±1.0kHz	18 min.[fo+9kHz]	18 min.[fo-9kHz]	7.0 max.	3000	2
SFZLA455KT2A-B0	456 ±2.0kHz	7.0 ±1.0kHz	16 min.[fo+9kHz]	16 min.[fo-9kHz]	6.0 max.	3000	2

Insertion Loss: at minimum loss point

Center frequency (fo) is defined by the center of 3dB bandwidth.

The order quantity should be an integral multiple of the "Minimum Quantity" shown in the package page.

■ Frequency Characteristics (CERAFIL® with IFT)

Part Number	6dB Band Width (kHz)	Selectivity		Input Level (at 0.6mV output) (dB)
		+9kHz off (dB)	-9kHz off (dB)	
IFT+SFULA455KU2B-B0	6.5	20	23	78
IFT+SFZLA455KN2A-B0	5.0		38	78
IFT+SFZLA455KS2A-B0	7.0		33	78
IFT+SFZLA455KT2A-B0	8.5		27	78

Typ. value

■ Recommended IFT (7x7)

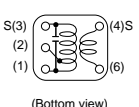
Item \ Type	SFULA□□L			SFZLA□□L		
Winding Specification	(1)–(2)	(2)–(3)	(4)–(6)	(1)–(2)	(2)–(3)	(4)–(6)
 (Bottom view)	70T	115T	7T	68T	84T	14T
No load Q_u	105			90		
Tuning Capacitance	180pF			180pF		

• Matching of CERAFIL®SFULA/SFZLA series with IFT is decided by the IFT secondary side impedance, $|Z_2|$. The design target values of $|Z_2|$ are :
For SFULA□□L : 300 Ω
For SFZLA□□L : 1k Ω

■ Test Circuit (CERAFIL® Only)

SFULA Series

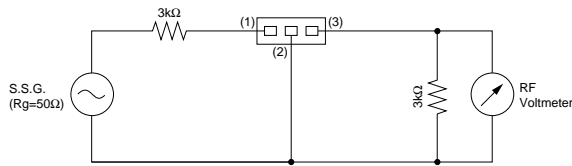

SFZLA Series

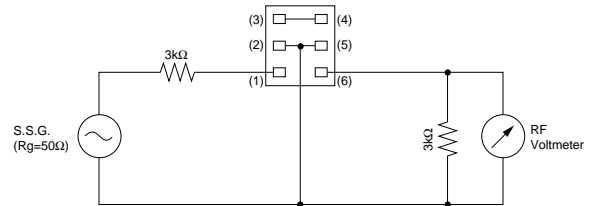

18

■ Test Circuit (CERAFIL® with IFT)

SFULA Series

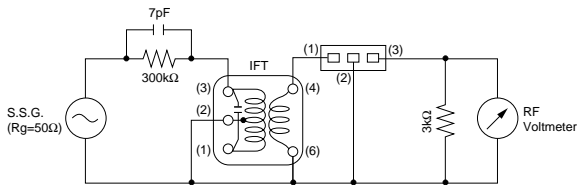

SFZLA Series

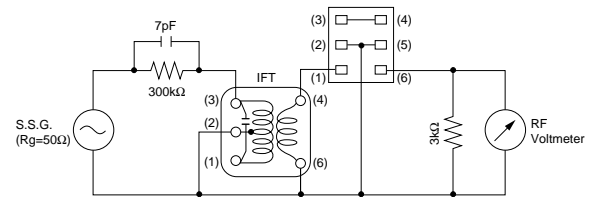

Frequency Characteristics

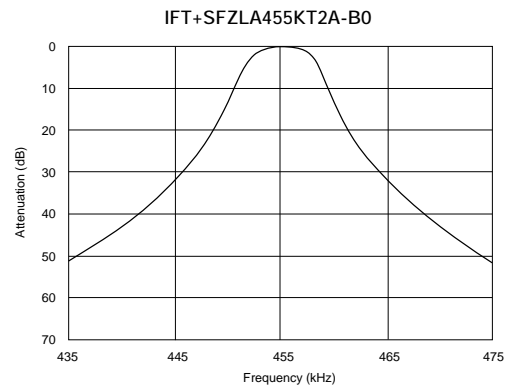
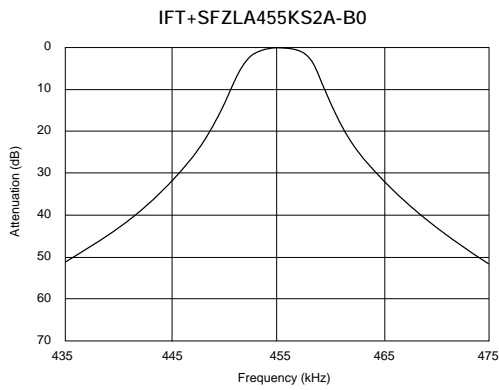
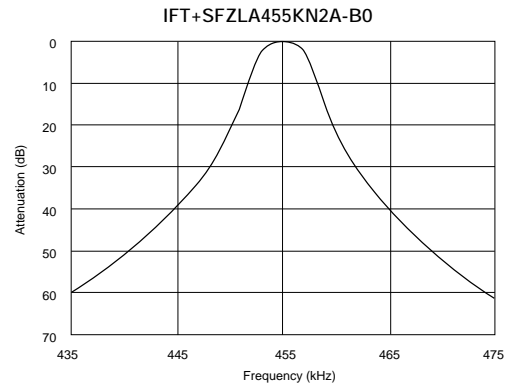
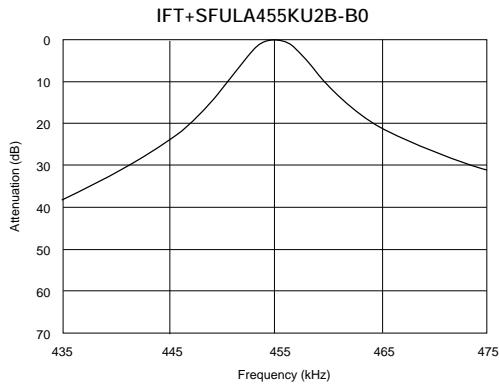

18

Frequency Characteristics (Spurious)

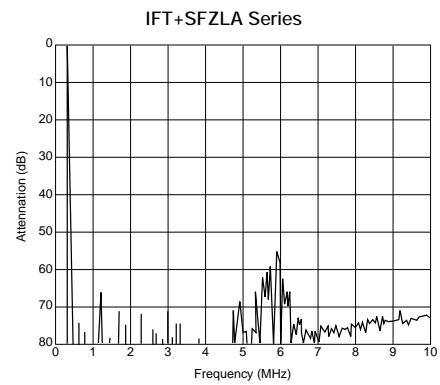
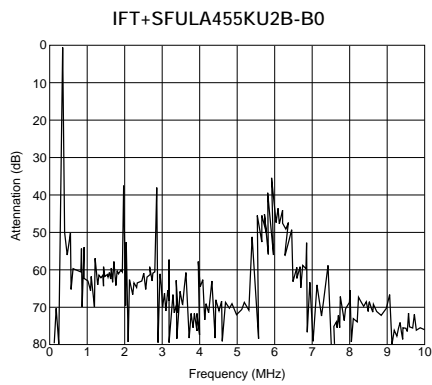

CERAFIL® (Filters/Traps/Discriminators) for Audio/Visual Equipment



CERAFIL® 455kHz PFSLA/PFWLA Series

PFSLA/PFWLA series for AM use is one of the most recommendable intermediate filters, having such distinctive features as high selectivity, high stability, and adjustment-free operation. Additionally its easy matching with IC helps create an easy circuit design. This is the most recommendable for portable radios with small package.

■ Features

1. Center frequency range between 450 to 470 kHz are available standard tolerance of ± 2 kHz.
2. For frequency synthesizers, center frequencies of 450, 459 and 468 kHz are available standard tolerance of ± 1 kHz.



PFSLA Series

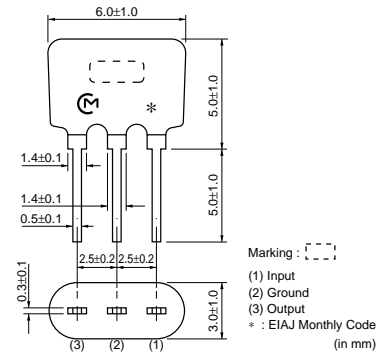

PFWLA Series

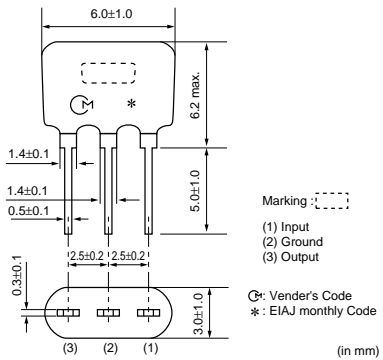

Part Number	Center Frequency (fo) (kHz)	3dB Bandwidth (kHz)	Selectivity (+) (dB)	Selectivity (-) (dB)	Insertion Loss (dB)	Input/Output Impedance (ohm)	Element
PFSLA455KP2A-B0	455 \pm 2.0kHz	4.5 \pm 1.5kHz	8 min. [fo+9kHz]	8 min. [fo-9kHz]	5.0 max.	3000	1
PFWLA450KP2A-B0	450 \pm 2.0kHz	4.5 \pm 1.5kHz	19 min. [fo+9kHz]	19 min. [fo-9kHz]	7.0 max.	3000	2
PFWLA450KS2A-B0	450 \pm 2.0kHz	5.5 \pm 1.5kHz	17 min. [fo+9kHz]	17 min. [fo-9kHz]	6.0 max.	3000	2

Insertion Loss: at minimum loss point

Center frequency (fo) is defined by the center of 3dB bandwidth.

The order quantity should be an integral multiple of the "Minimum Quantity" shown in the package page.

■ Recommended IFT

Item \ Type	7×7mm IFT			5×5mm IFT		
	(1)–(2)	(2)–(3)	(4)–(6)	(1)–(2)	(2)–(3)	(4)–(6)
Winding Specification	(1)–(2)	(2)–(3)	(4)–(6)	(1)–(2)	(2)–(3)	(4)–(6)
S(3) (2) (1)  (Bottom view)	85T	67T	23T	84T	98T	33T
No load Q_u	90			65		
Tuning Capacitance	180pF			180pF		

* Matching of CERAFIL®PFWLA series with IFT is decided by the IFT secondary side impedance, |Z₂|. Set the |Z₂| at about 4.2kΩ.

■ Test Circuit (CERAFIL® Only)

PFSLA/PFWLA Series

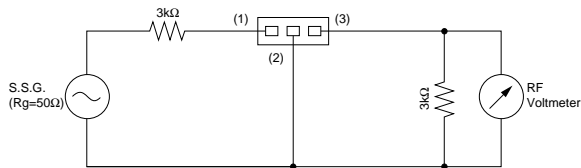

■ Test Circuit (CERAFIL® with IFT)

PFSLA/PFWLA Series

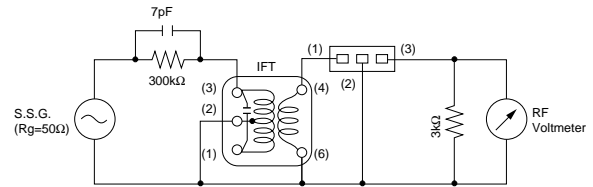

■ Frequency Characteristics

IFT+PFSLA455KP2A-B0

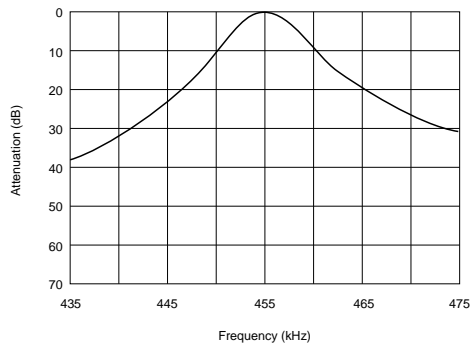

IFT+PFWLA450KS2A-B0

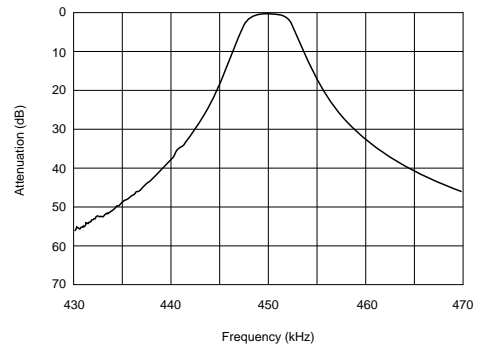

19

■ Frequency Characteristics (Spurious)

IFT+PFSLA455KP2A-B0

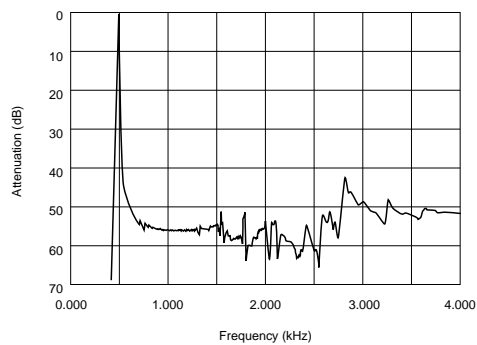

IFT+PFWLA450KS2A-B0

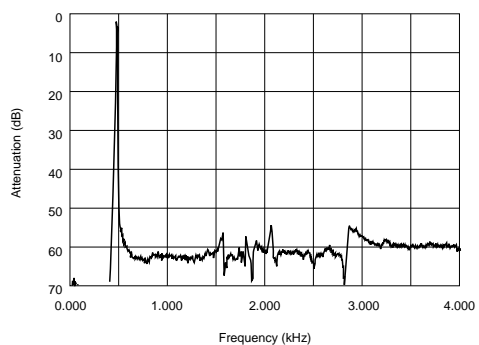

CERAFIL® (Filters/Traps/Discriminators) for Audio/Visual Equipment



CERAFIL® 455kHz SFPLA/CFWLA Series

■ Features

SFPLA/CFWLA series for AM use is one of the most recommendable intermediate filters, having such distinctive features as high selectivity, high stability, high attenuation, and adjustment-free operation. Additionally its easy matching with IC helps create an easy circuit design. This is the most recommendable for car-stereo and all band radio with high attenuation.



SFPLA Series

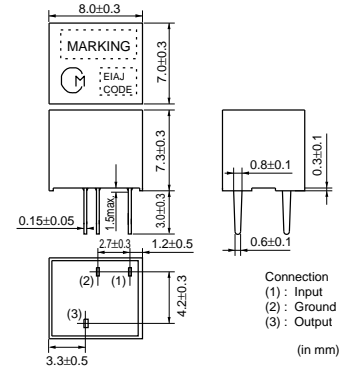

CFWLA Series

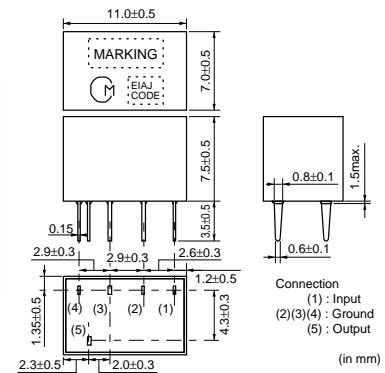

Part Number	Center Frequency (fo) (kHz)	6dB Bandwidth (kHz)	Selectivity (+) (dB)	Selectivity (-) (dB)	Insertion Loss (dB)	Input/Output Impedance (ohm)	Element
SFPLA450KJ1A-B0	450 ±1.0kHz	fn±2.0 min.	40 min.[fn+7.5kHz]	40 min.[fn-7.5kHz]	6.0 max.	2000	4
SFPLA450KH1A-B0	450 ±1.0kHz	fn±3.0 min.	40 min.[fn+9kHz]	40 min.[fn-9kHz]	6.0 max.	2000	4
CFWLA450KJFA-B0	450 (fn)	fn±2.0 min.	50 min.[fn+7.5kHz]	50 min.[fn-7.5kHz]	7.0 max.	2000	6
CFWLA450KHFA-B0	450 (fn)	fn±3.0 min.	50 min.[fn+9kHz]	50 min.[fn-9kHz]	6.0 max.	2000	6

Insertion Loss: at minimum loss point

Center frequency (fo) is defined by the center of 6dB bandwidth.

(fn) means nominal center frequency (450kHz).

For safety purposes, connect the output of filters to the IF amplifier through a D.C. blocking capacitor. Avoid applying a direct current to the output of ceramic filters.

The order quantity should be an integral multiple of the "Minimum Quantity" shown in the package page.

■ Recommended IFT (7x7)

Item	Type	SFPLA/CFWLA/CFWLA		
Winding Specification		(1)—(2)	(2)—(3)	(4)—(6)
S(3) (2) (1)		60T	125T	28T
No load Qu		40		
Tuning Capacitance		180pF		

* Matching of CERAFIL® SFPLA/CFWLA/CFWLA series with IFT is decided by the Qu of IFT and IFT secondary side impedance, [Z2]. Set the Qu at about 40 because a Qu value which is too high (e.g., 90) may produce ripple in the waveform. It is recommended to match the impedance of [Z2] with that of the CERAFIL®.

■ Test Circuit

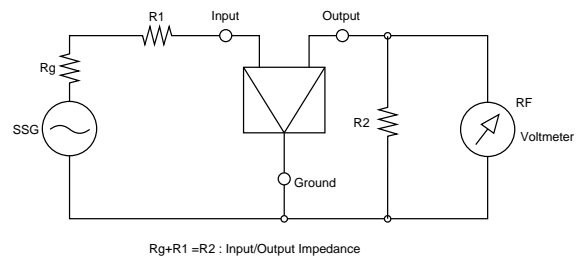

Continued on the following page.

Continued from the preceding page.

Frequency Characteristics

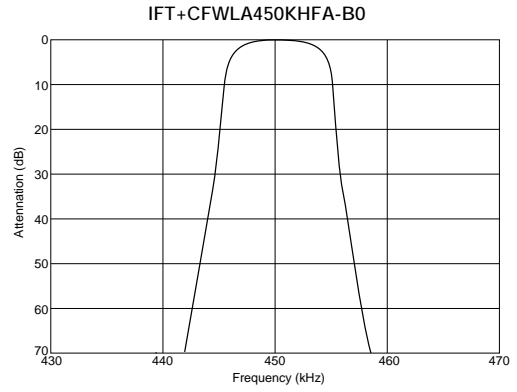
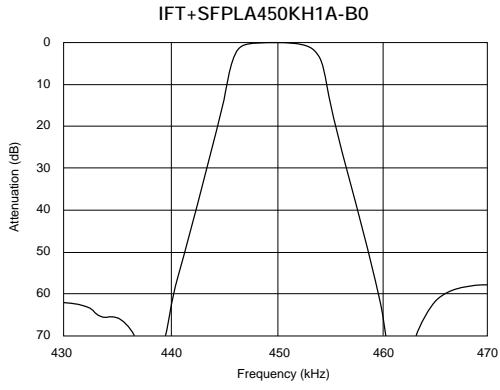

Frequency Characteristics (Spurious)

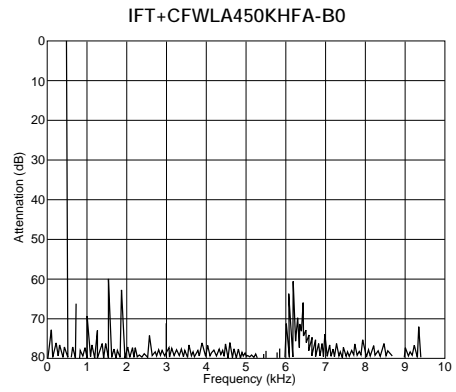
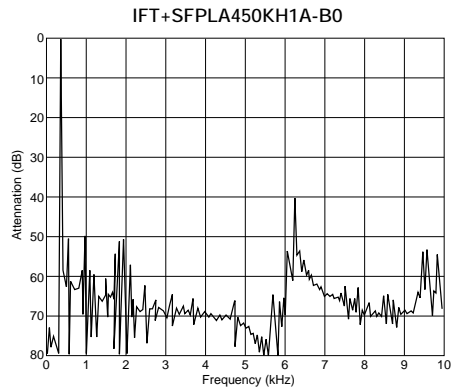

CERAFIL® (Filters/Traps/Discriminators) for Audio/Visual Equipment



CERAFIL® 455kHz for AM Stereo Wide Bandwidth Type SFPLA/CFWLA/CFULA Series

■ Features

SFPLA/CFWLA/CFULA series for AM use is one of the most recommendable intermediate filters, having such distinctive features as high selectivity, high stability, high attenuation, and adjustment-free operation. Additionally its easy matching with IC helps create an easy circuit design. Especially, CFULA/CFWLA_Y series is the frequency fidelity in the high sound area of an AM stereo will be improved with wide band, flat group delay time characteristics.



SFPLA Series

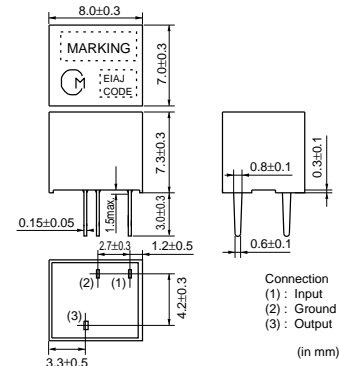

CFWLA Series

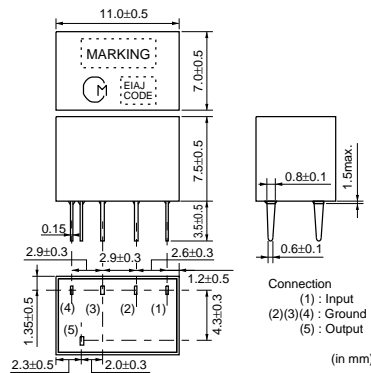

CFULA Series

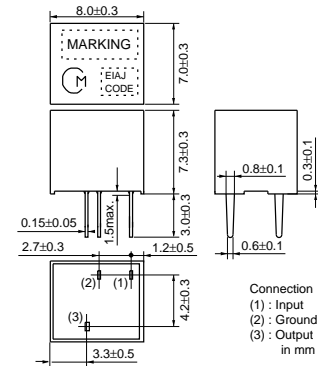

Part Number	Center Frequency (fo) (kHz)	6dB Bandwidth (kHz)	Selectivity (+) (dB)	Selectivity (-) (dB)	Insertion Loss (dB)	GDT 20μsec. Bandwidth (kHz)	Input/Output Impedance (ohm)	Element
SFPLA450KG1A-B0	450 ±1.0kHz	fn±4.5 min.	30 min.[fn+9kHz]	30 min.[fn-9kHz]	6.0 max.	-	2000	4
SFPLA450KF1A-B0	450 ±1.0kHz	fn±6.0 min.	40 min.[fn+12.5kHz]	40 min.[fn-12.5kHz]	6.0 max.	-	2000	4
SFPLA450KE1A-B0	450 ±1.0kHz	fn±7.5 min.	40 min.[fn+15kHz]	40 min.[fn-15kHz]	6.0 max.	-	1500	4
SFPLA450KD1A-B0	450 ±1.0kHz	fn±10.0 min.	40 min.[fn+20kHz]	40 min.[fn-20kHz]	4.0 max.	-	1500	4
CFWLA450KGFA-B0	450 (fn)	fn±4.5 min.	50 min.[fn+10kHz]	50 min.[fn-10kHz]	6.0 max.	-	2000	6
CFWLA450KFFA-B0	450 (fn)	fn±6.0 min.	50 min.[fn+12.5kHz]	50 min.[fn-12.5kHz]	6.0 max.	-	2000	6
CFWLA450KEFA-B0	450 (fn)	fn±7.5 min.	50 min.[fn+15kHz]	50 min.[fn-15kHz]	6.0 max.	-	1500	6
CFWLA450K DFA-B0	450 (fn)	fn±10.0 min.	50 min.[fn+20kHz]	50 min.[fn-20kHz]	4.0 max.	-	1500	6
CFWLA450KG1Y-B0	450 ±1.0kHz	fn±4.5 min.	50 min.[fn+15kHz]	50 min.[fn-15kHz]	11.0 max.	fn±4.0	2000	6
CFULA450KG1Y-B0	450 ±1.0kHz	fn±4.5 min.	40 min.[fn+15kHz]	40 min.[fn-15kHz]	10.0 max.	fn±4.5	2000	4
CFWLA450KF1Y-B0	450 ±1.0kHz	fn±6.0 min.	50 min.[fn+17.5kHz]	50 min.[fn-17.5kHz]	10.0 max.	fn±5.0	2000	6
CFULA450KF1Y-B0	450 ±1.0kHz	fn±6.0 min.	40 min.[fn+17.5kHz]	40 min.[fn-17.5kHz]	9.0 max.	fn±6.0	2000	4
CFWLA450KD1Y-B0	450 ±1.0kHz	fn±10.0 min.	50 min.[fn+25kHz]	50 min.[fn-25kHz]	8.0 max.	fn±8.0	1500	6
CFULA450KD1Y-B0	450 ±1.0kHz	fn±10.0 min.	40 min.[fn+25kHz]	40 min.[fn-25kHz]	7.0 max.	fn±9.0	1500	4

Insertion Loss: at minimum loss point

Center frequency (fo) is defined by the center of 6dB bandwidth.

(fn) means nominal center frequency (450kHz).

For safety purposes, connect the output of filters to the IF amplifier through a D.C. blocking capacitor. Avoid applying a direct current to the output of ceramic filters.

The order quantity should be an integral multiple of the "Minimum Quantity" shown in the package page.

Recommended IFT (7x7)

Item	Type	SFPLA/CFULA/CFWLA		
Winding Specification	(1)—(2)	(2)—(3)	(4)—(6)	
S(3) (2) (1)		60T	125T	28T
(Bottom view)				
No load Qu		40		
Tuning Capacitance		180pF		

• Matching of CERAFIL®SFPLA/CFULA/CFWLA series with IFT is decided by the Qu of IFT and IFT secondary side impedance, [Z2]. Set the Qu at about 40 because a Qu value which is too high (e.g.,90) may produce ripple in the waveform. It is recommended to match the impedance of [Z2] with that of the CERAFIL®.

Test Circuit

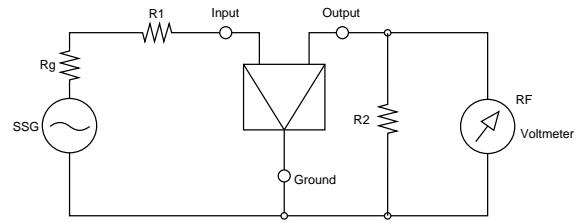

$R_g + R_1 = R_2$: Input/Output Impedance

Frequency Characteristics

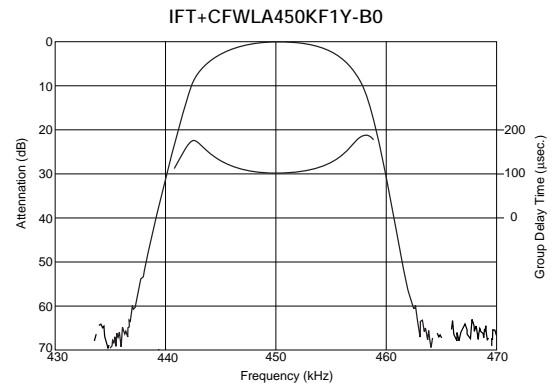
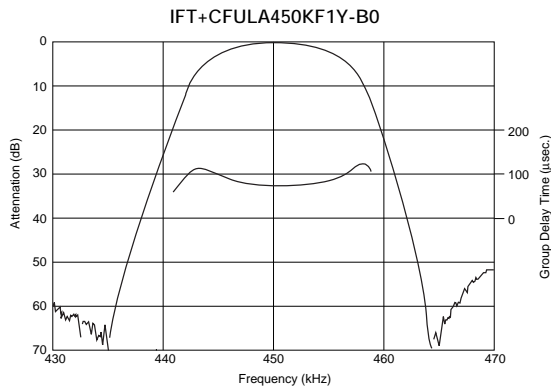
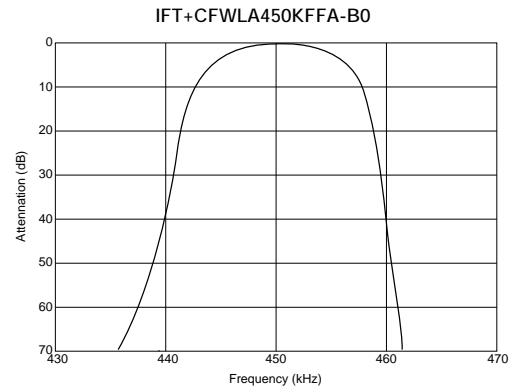
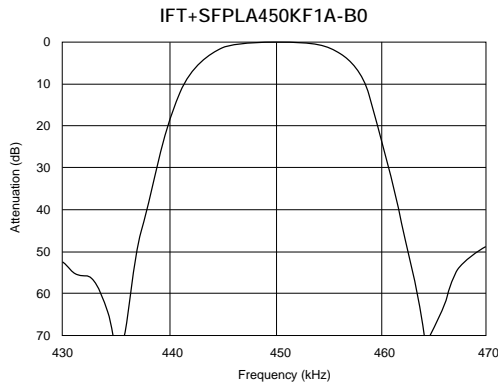

CERAFIL® (Filters/Traps/Discriminators) for Audio/Visual Equipment



CERAFIL® 455kHz for Search-stop Signal Detection

BFULA series are narrow bandwidth filters. This filter is used in the application which detects the carrier peak with a narrow bandwidth amplifier, or an electronic tuner as a stop signal detector.

■ Features

Most suitable for IC Station Detectors (SD).

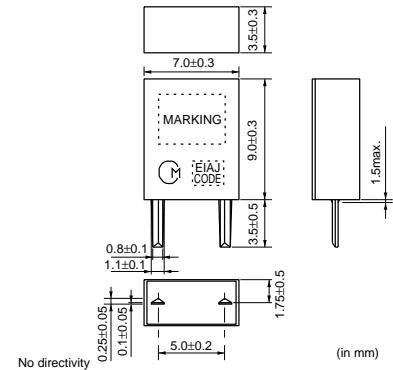

Part Number	Resonant Frequency (Fr) (kHz)	Delta F (Fa-Fr) (kHz)	Resonant Resistance (ohm)	Capacitance (pF)
BFULA450KC-B0	450 ±1.0kHz	14.0 ±2.0kHz	20 max.	360 ±20%
BFULA450KC004-B0	450 ±0.8kHz	9.0 ±2.0kHz	30 max.	360 ±20%
BFULA450KK003-B0	450 ±1.0kHz	27.5 ±4.5kHz	30 max.	550 ±20%

fa-fr means difference between the anti-resonant frequency and the resonant frequency.
The order quantity should be an integral multiple of the "Minimum Quantity" shown in the package page.

■ Impedance Characteristics

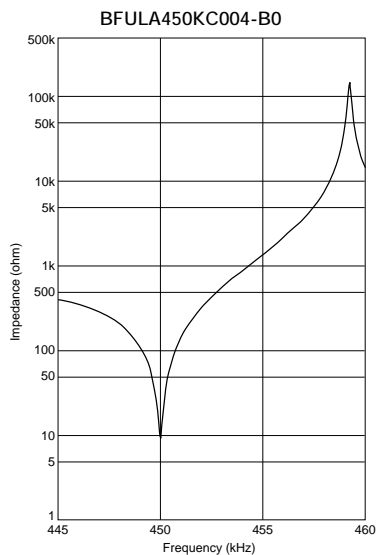

CERAFIL® 455kHz SF/PF Series Temperature Characteristics

■ SFZLA455KS2A-B0

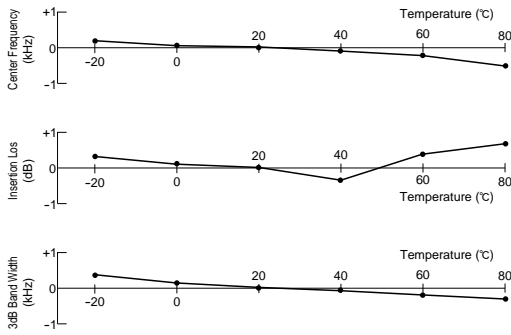

■ SFPLA450KH1A-B0

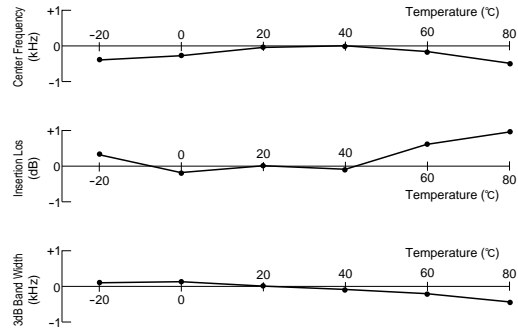

■ PFWLA450KS2A-B0

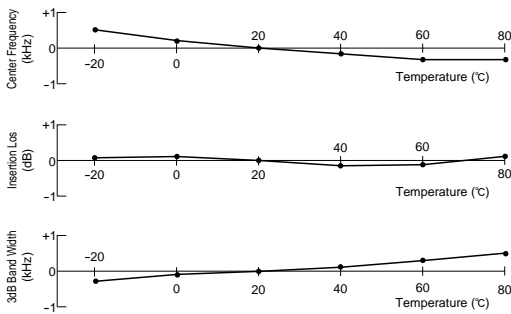

CERAFIL® 455kHz SF/PF/BF Series Application Circuit

■ Car Radio

SFPLA450KH1A-B0/BFULA450KC004-B0

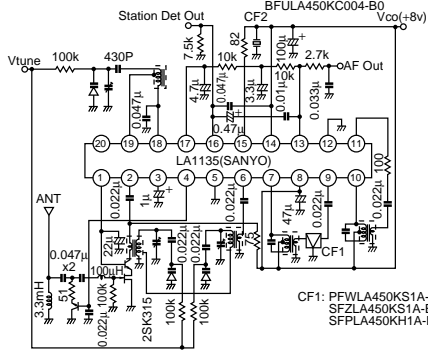

PFSLA455KP2A-B0/PFWLA450KS2A-B0

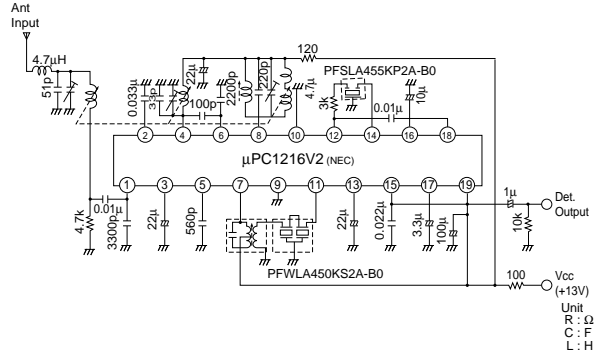

■ Portable Radio

SFULA455KU2B-B0

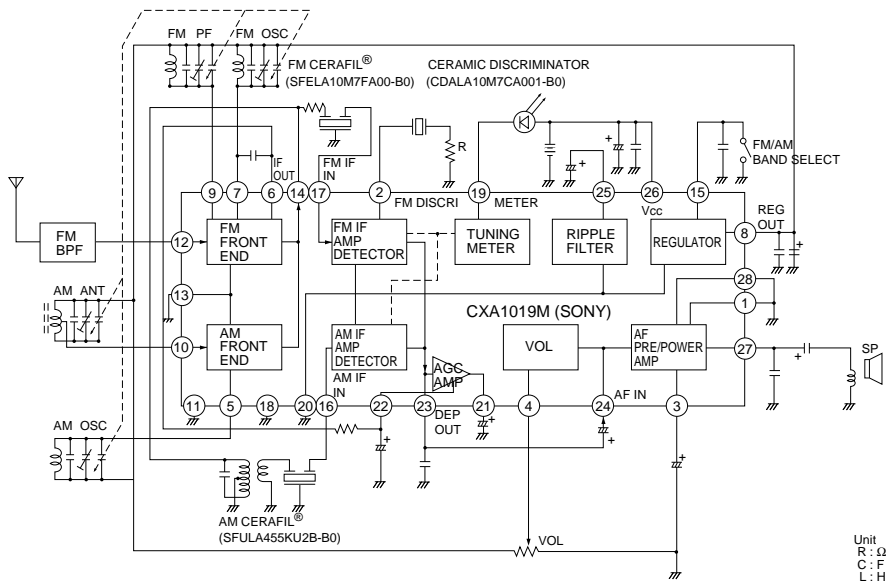

Continued on the following page. ↗

CERAFIL® 455kHz SF/PF/BF Series Application Circuit

Continued from the preceding page.

Portable Radio

SFULA455KU2B-B0

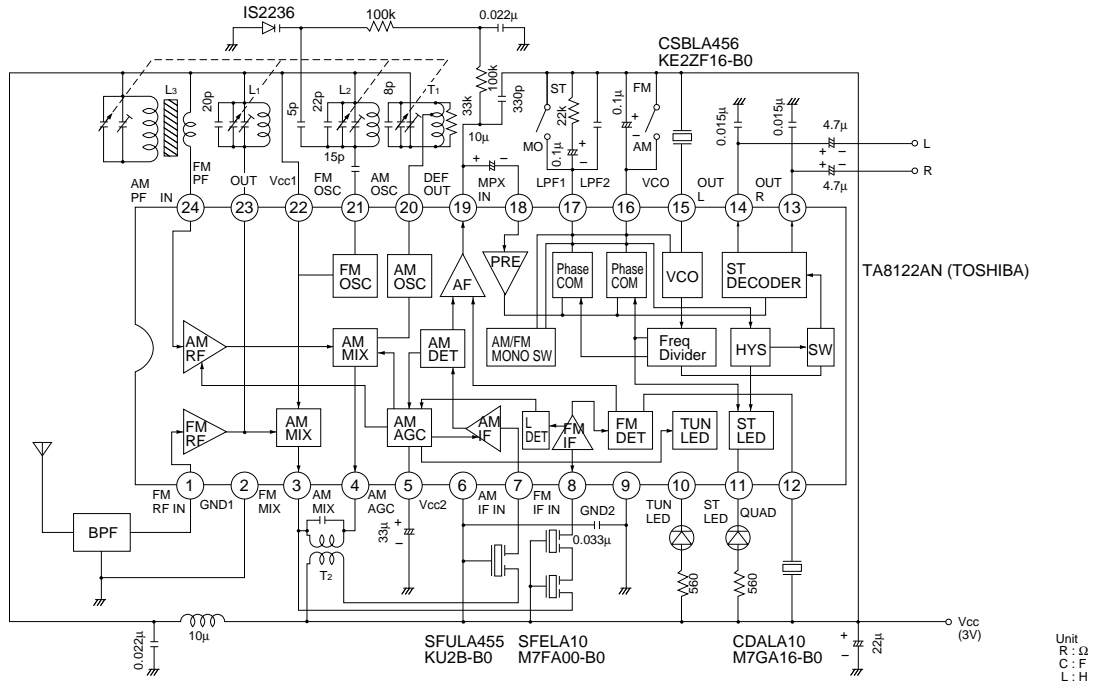

In Tr Circuit

BFULA450KK003-B0

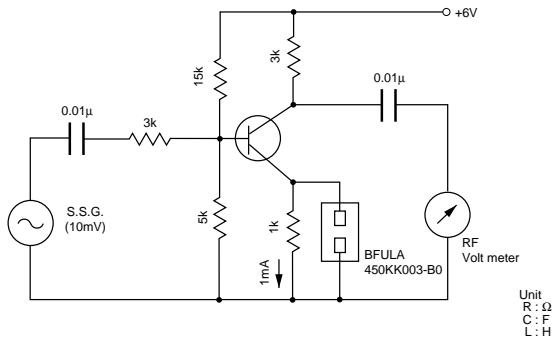

CERAFIL® (Filters/Traps/Discriminators) for Audio/Visual Equipment



Ceramic Trap 4.5-6.5MHz Chip Type TPSKA Series

SMD ceramic trap TPSKA_B is small and thin SMD trap sealed with a metal cap. Recommended for LCD-TV's, and small and thin tuners.

■ Features

1. High attenuation and high performance group delay time
2. Small and thin package
3. Reflow-solderable

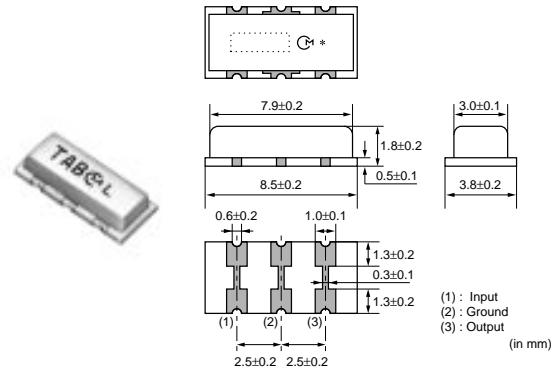

Part Number	Nominal Center Frequency (fn1) (MHz)	Attenuation (at fn1) (dB)	30dB Attenuation BW (fn1) (kHz)
TPSKA4M50B00-R1	4.500	35 min.	50 min.

The order quantity should be an integral multiple of the "Minimum Quantity" shown in the package page.

■ Standard Land Pattern Dimensions

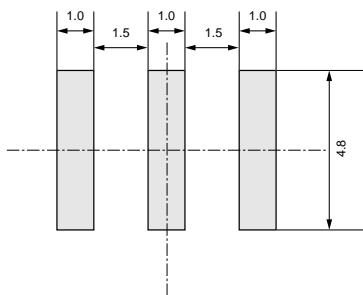

■ Test Circuit

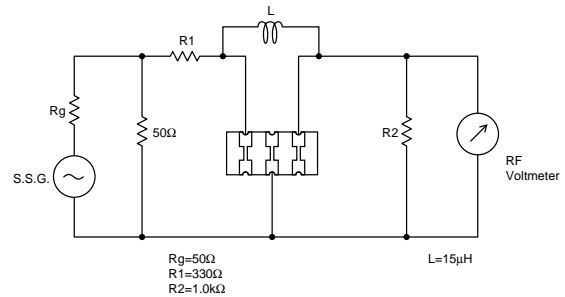

23

■ Frequency Characteristics

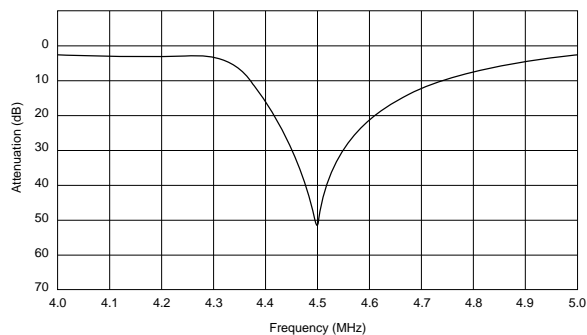

■ Frequency Characteristics (Spurious)

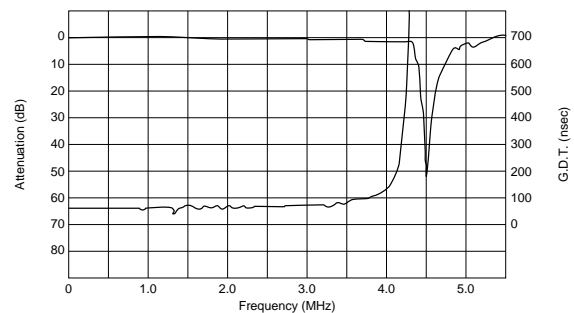

CERAFIL® (Filters/Traps/Discriminators) for Audio/Visual Equipment



Ceramic Trap 4.5-6.5MHz Chip Type Double Traps TPWKA Series

SMD ceramic trap TPWKA is small and thin SMD trap sealed with a metal cap. Recommended for LCD-TV's, and small and thin tuners.

This series consist of 2 wafers with 2 trap frequencies. Recommended for Multi standard set.

■ Features

1. Good performance of attenuation
2. Small and thin package
3. Reflow-solderable

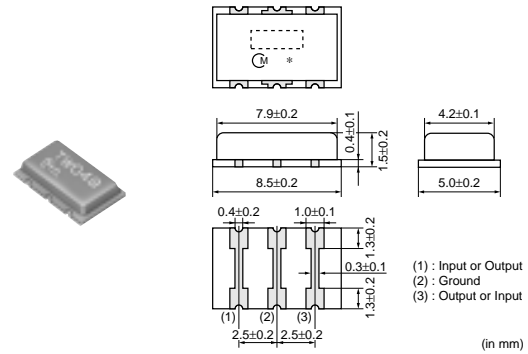

Part Number	Nominal Center Frequency (fn1) (MHz)	Nominal Center Frequency (fn2) (MHz)	Attenuation (at fn1) (dB)	Attenuation (at fn2) (dB)	30dB Attenuation BW (fn1) (kHz)
TPWKA5M50B04-R1	5.500	5.742	30 min.	30 min.	50 min.

The order quantity should be an integral multiple of the "Minimum Quantity" shown in the package page.

■ Standard Land Pattern Dimensions

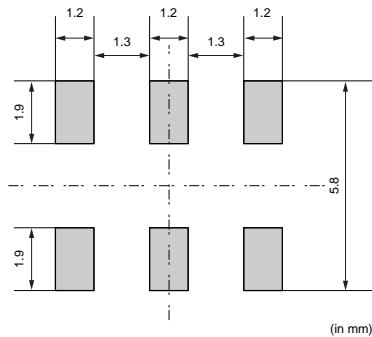

■ Test Circuit

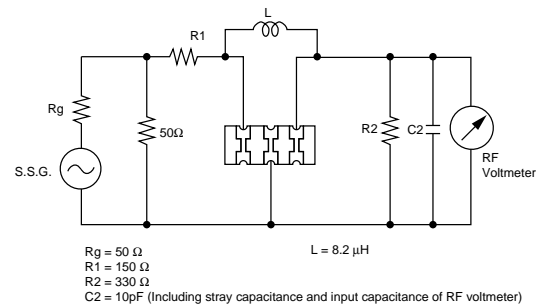

■ Frequency Characteristics

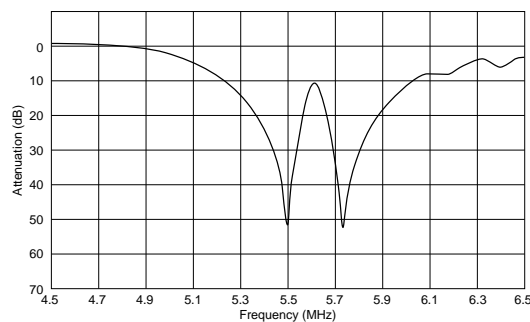

■ Frequency Characteristics (Spurious)

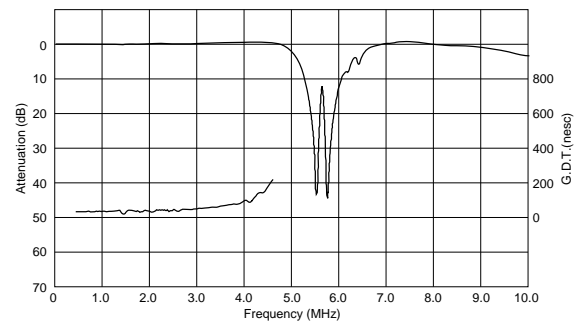

CERAFIL® (Filters/Traps/Discriminators) for Audio/Visual Equipment



Ceramic Trap 4.5-6.5MHz Standard Lead Type TPSRA Series

As part of the environment protection activity, solder for terminal plating and terminal-element connection inside of ceramic filter TPSRA series contain no lead (Pb).

This series consist of two trap element on one wafer. Suitable for the sound IF trap of CTV/VCR.

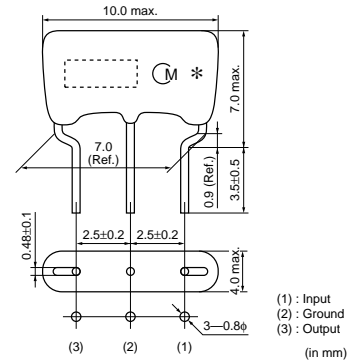

■ Features

1. Good performance of attenuation
2. Shape factor can be changed by the value of Inductor "L".
3. Three-terminals type
4. Low profile (H=7.0mm max.)
5. Lead dimension:
Improved mounting reliability (cut & clinch) due to round terminal.

Part Number	Nominal Center Frequency (fn1) (MHz)	Attenuation (at fn1) (dB)	30dB Attenuation BW (fn1) (kHz)
TPSRA4M50B00-B0	4.500	35 min.	50 min.
TPSRA4M50C00-B0	4.500	30 min.	-
TPSRA5M50B00-B0	5.500	35 min.	70 min.
TPSRA5M74B00-B0	5.742	35 min.	70 min.
TPSRA6M00B00-B0	6.000	35 min.	70 min.
TPSRA6M50B00-B0	6.500	35 min.	70 min.

The order quantity should be an integral multiple of the "Minimum Quantity" shown in the package page.

■ Test Circuit

TPSRA4M50B00-B0

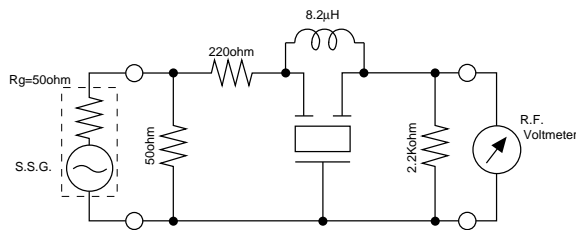

TPSRA4M50C00-B0

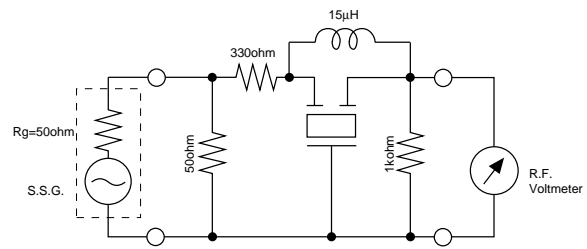

Continued on the following page. ↗

Continued from the preceding page.

■ Test Circuit

TPSRA5M50/5M74/6M00/6M50B00-B0

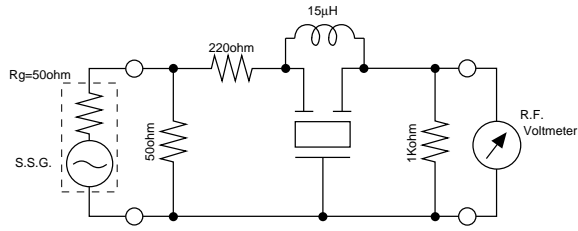

■ Frequency Characteristics

TPSRA4M50B00-B0

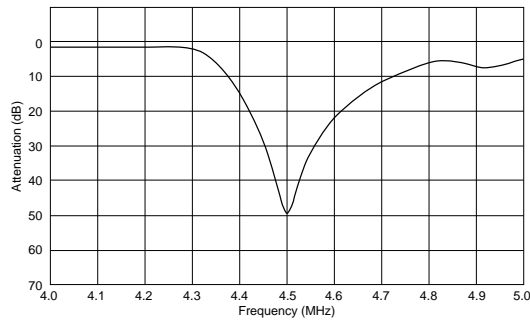

TPSRA4M50C00-B0

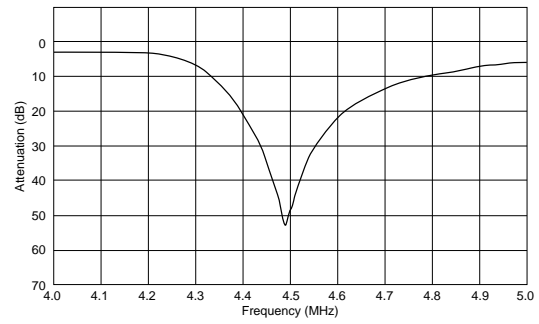

TPSRA5M50B00-B0

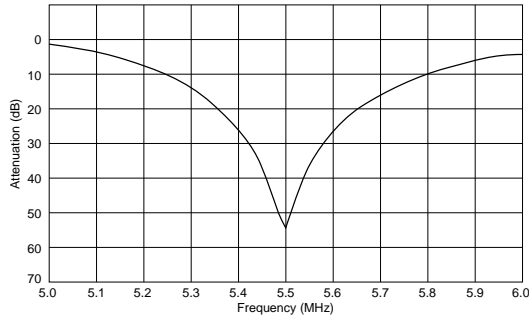

TPSRA5M74B00-B0

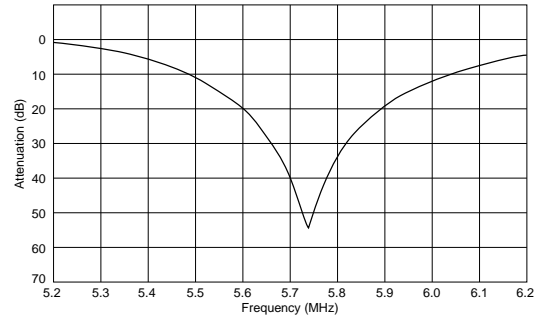

TPSRA6M00B00-B0

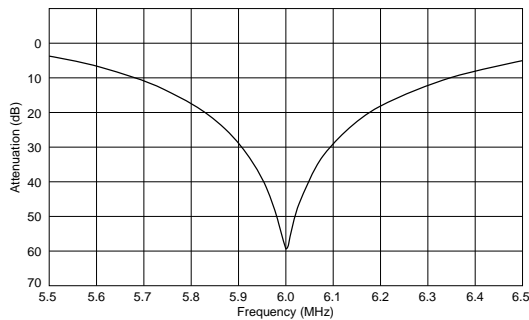

TPSRA6M50B00-B0

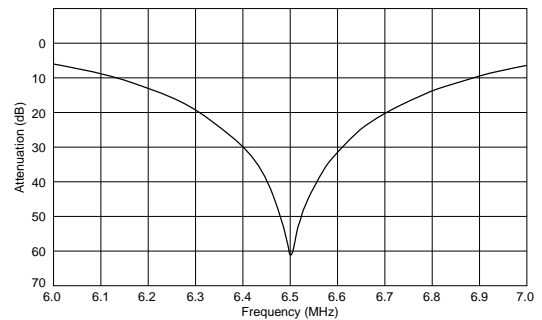

25

Continued on the following page. ↗

Continued from the preceding page.

Frequency Characteristics (Spurious)

TPSRA4M50B00-B0

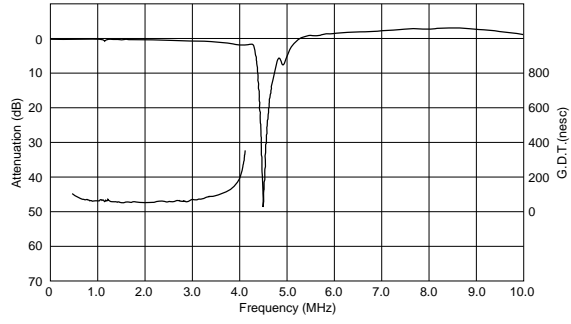

TPSRA4M50C00-B0

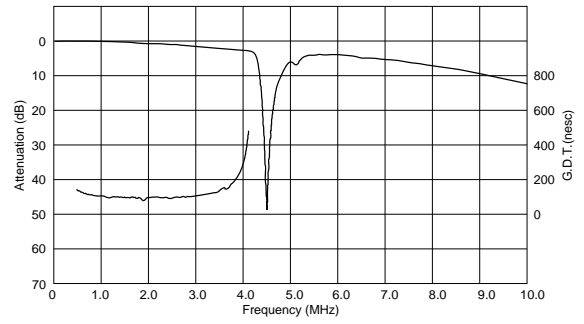

TPSRA5M50B00-B0

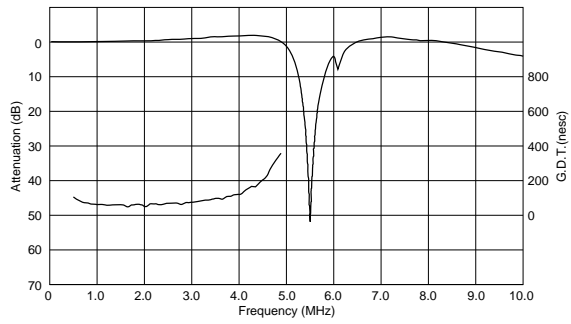

TPSRA5M74B00-B0

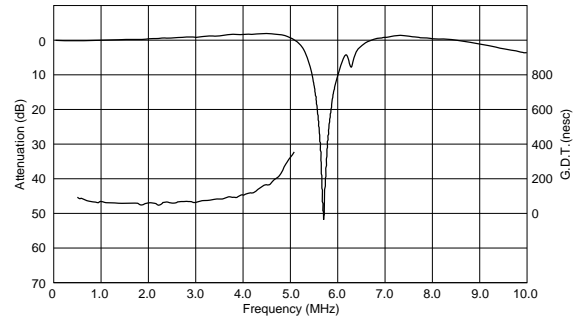

TPSRA6M00B00-B0

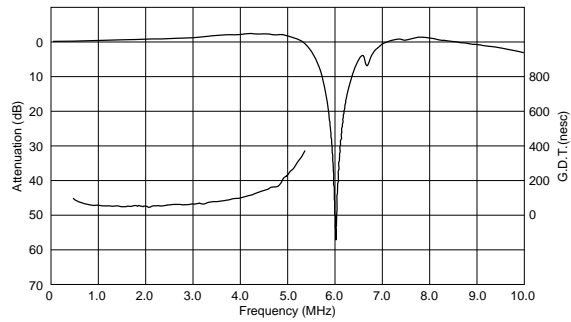

TPSRA6M50B00-B0

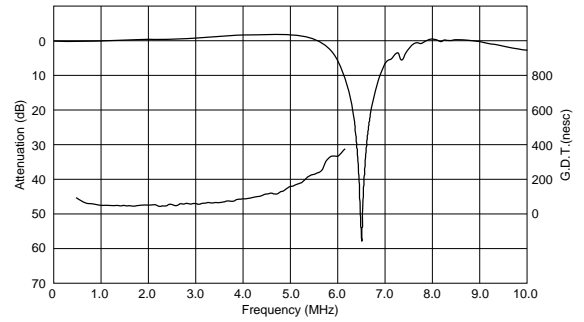

CERAFIL® (Filters/Traps/Discriminators) for Audio/Visual Equipment



Ceramic Trap 3.5-6.5MHz Two Lead Type TPSRD Series

Ceramic Trap TPSRD_J series are two-terminals type. Which are recommended for the attenuation of sound IF in B/W TV and the attenuation of chroma signal in Video Camcorder.

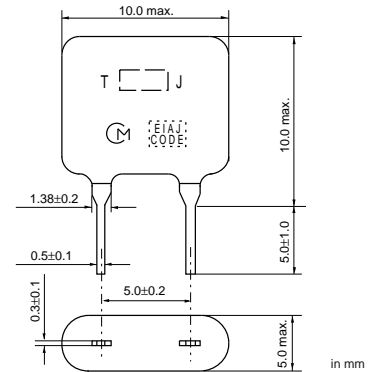

■ Features

1. Small-size, lightweight
2. High performance, durability
3. Easy to design due to two-terminals type

Part Number	Nominal Center Frequency (fn1) (MHz)	Attenuation (at fn1) (dB)	30dB Attenuation BW (fn1) (kHz)
TPSRD3M58J00-B0	3.580	20 min.	20 min.[20dB Att.BW]
TPSRD4M43J00-B0	4.430	20 min.	40 min.[20dB Att.BW]
TPSRD4M50J00-B0	4.500	20 min.	30 min.[20dB Att.BW]
TPSRD5M50J00-B0	5.500	20 min.	30 min.[20dB Att.BW]
TPSRD6M00J00-B0	6.000	20 min.	40 min.[20dB Att.BW]
TPSRD6M50J00-B0	6.500	20 min.	40 min.[20dB Att.BW]

The order quantity should be an integral multiple of the "Minimum Quantity" shown in the package page.

■ Test Circuit

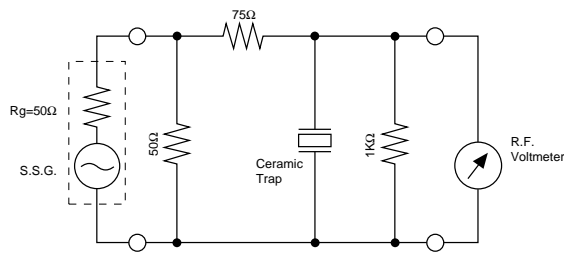

■ Frequency Characteristics

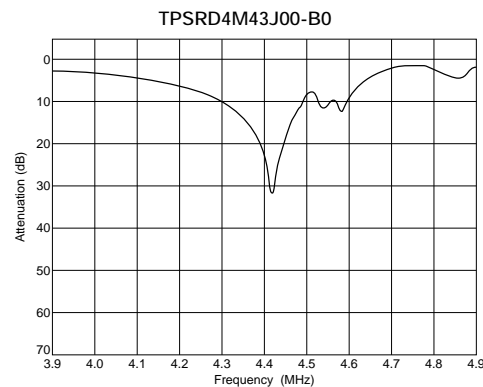
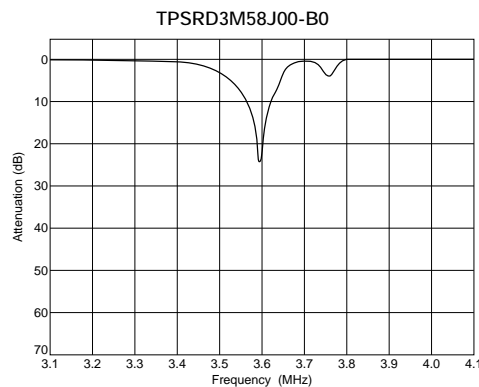

Continued on the following page.

Continued from the preceding page.

Frequency Characteristics

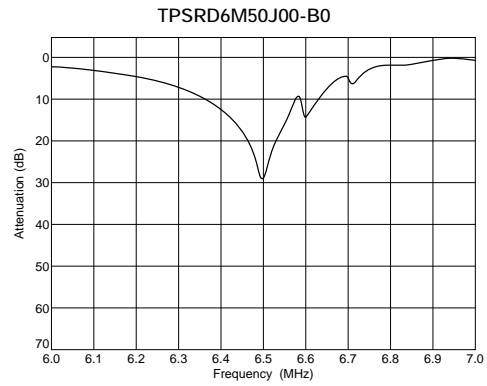
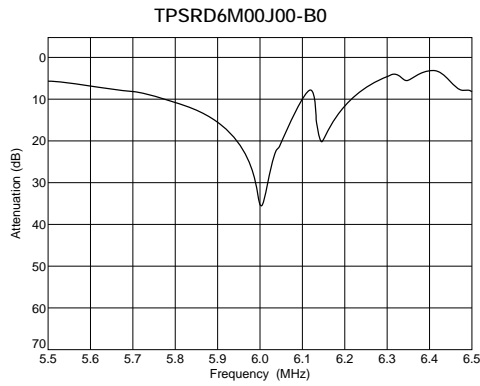
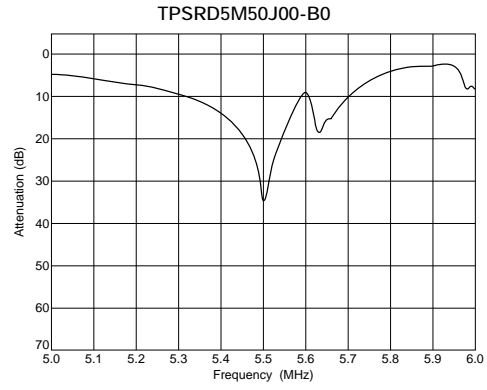
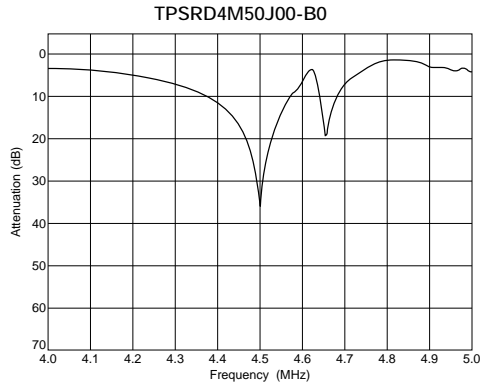

Frequency Characteristics (Spurious)

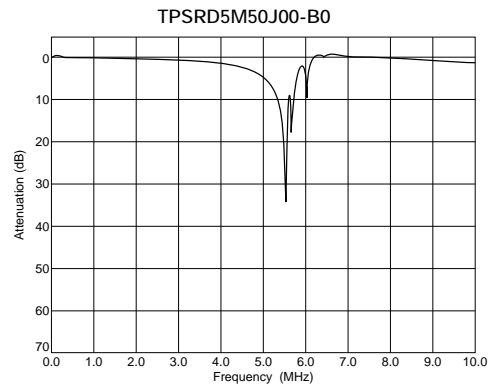
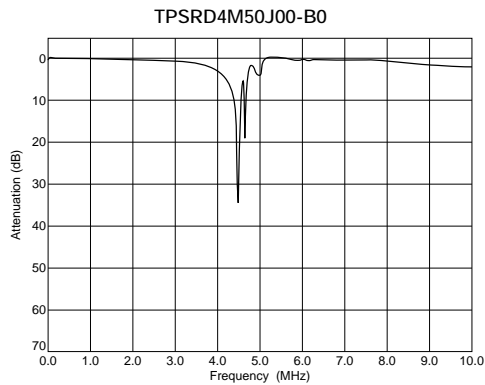
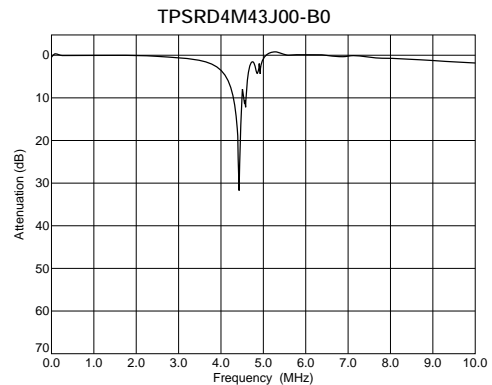
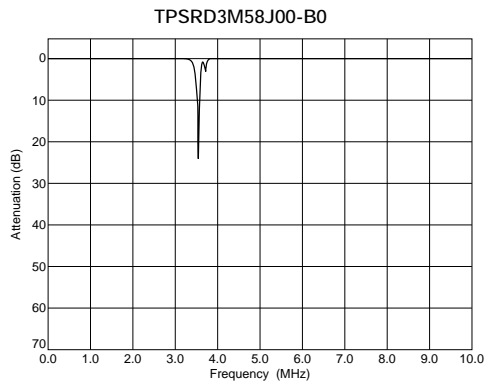

Continued from the preceding page.

Frequency Characteristics (Spurious)

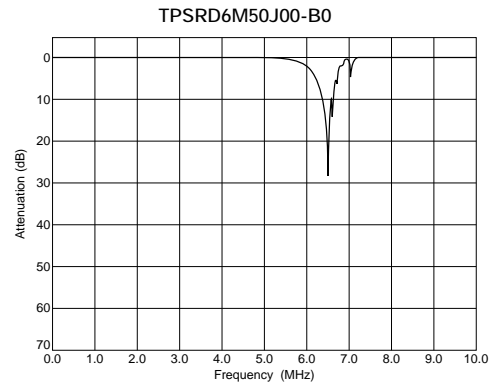
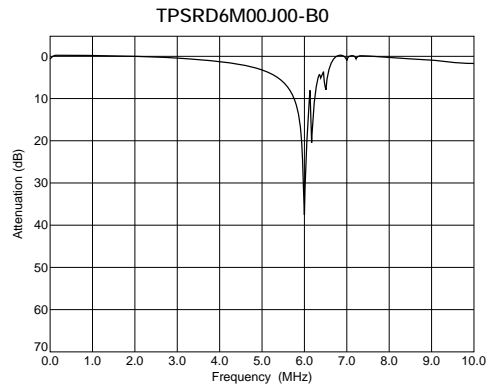

CERAFIL® (Filters/Traps/Discriminators) for Audio/Visual Equipment



Ceramic Trap 3.5-6.5MHz for 2ch Sound TV in Germany TPSRD Series

Ceramic trap TPSRD_W series has same structure as TPSRD_B series. But they can trap two individual frequencies at one time. Recommended for two channel multi-sound TV systems.

■ Features

1. Space saving
2. Three-terminals type

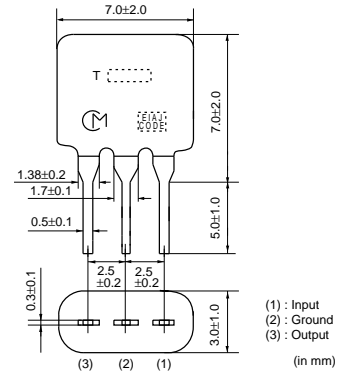

Part Number	Nominal Center Frequency (fn1) (MHz)	Nominal Center Frequency (fn2) (MHz)	Attenuation (at fn1) (dB)	Attenuation (at fn2) (dB)	30dB Attenuation BW (fn1) (kHz)
TPSRD5M50W00-B0	5.500	5.742	32 min.	25 min.	70 min.

The order quantity should be an integral multiple of the "Minimum Quantity" shown in the package page.

■ Test Circuit

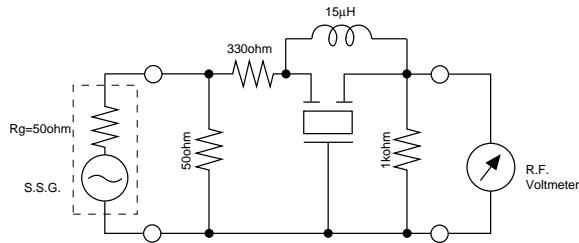

■ Frequency Characteristics

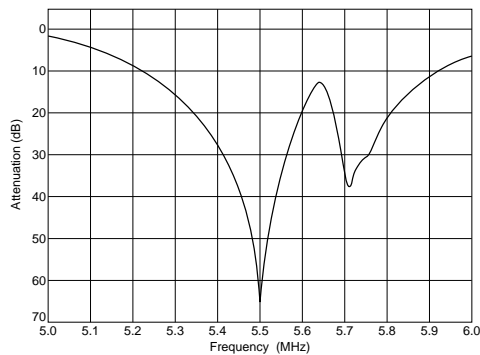

■ Frequency Characteristics (Spurious)

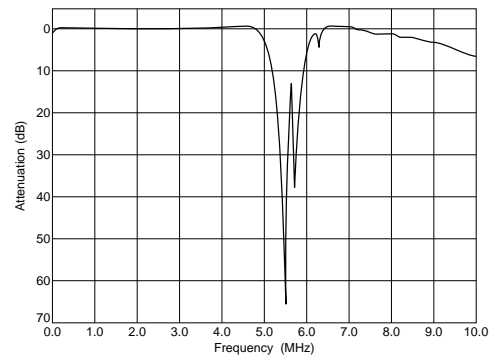

CERAFIL® (Filters/Traps/Discriminators) for Audio/Visual Equipment



Ceramic Trap 3.5-6.5MHz Double Traps TPWRD Series

Ceramic trap TPWRD_B series consist of two wafers with two trap frequencies. Recommended for Dual standard sets.

■ Features

1. Good performance of attenuation
2. Small and thin package
3. Three-terminals type

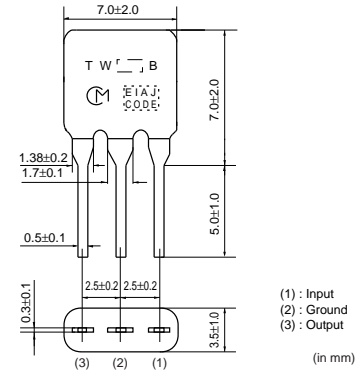

Part Number	Nominal Center Frequency (fn1) (MHz)	Nominal Center Frequency (fn2) (MHz)	Attenuation (at fn1) (dB)	Attenuation (at fn2) (dB)	30dB Attenuation BW (fn1) (kHz)
TPWRD5M50B02-B0	5.500	6.500	30 min.	30 min.	50 min.
TPWRD5M50B03-B0	5.500	6.000	30 min.	30 min.	50 min.
TPWRD5M50B04-B0	5.500	5.742	30 min.	30 min.	50 min.
TPWRD6M00B01-B0	6.000	6.500	30 min.	30 min.	70 min.

The order quantity should be an integral multiple of the "Minimum Quantity" shown in the package page.

■ Test Circuit

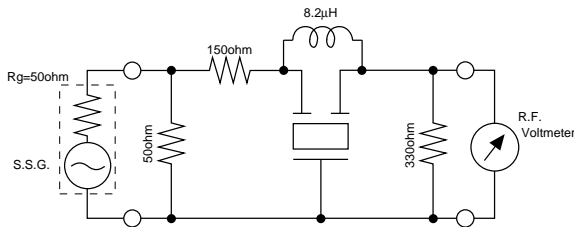

■ Frequency Characteristics

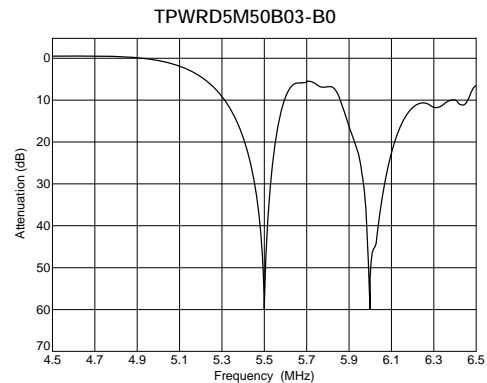
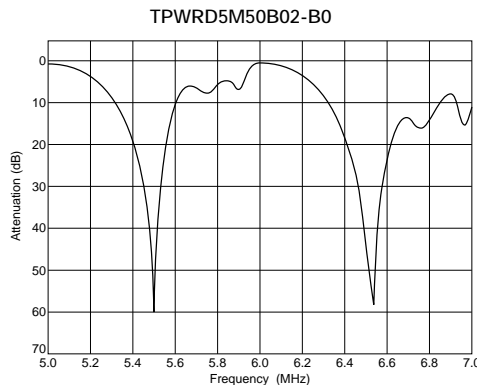

Continued on the following page. ↗

↳ Continued from the preceding page.

■ Frequency Characteristics

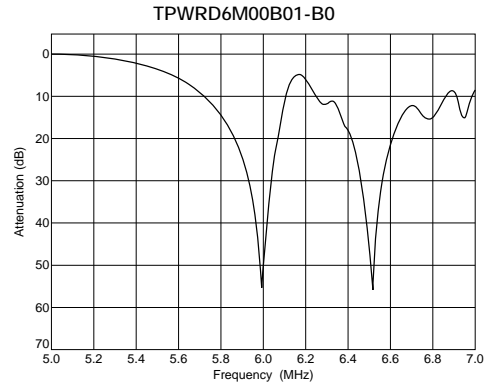
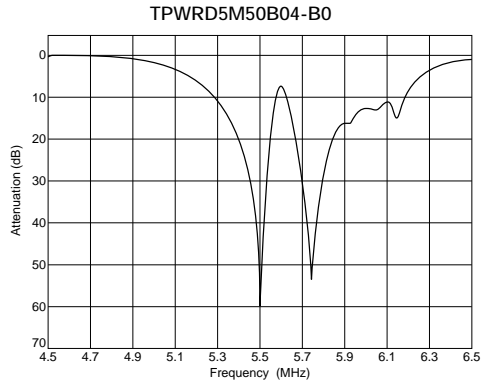

■ Frequency Characteristics (Spurious)

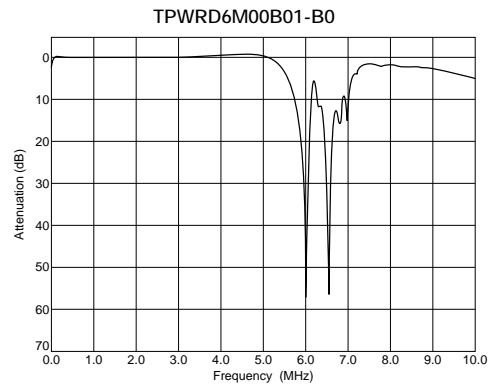
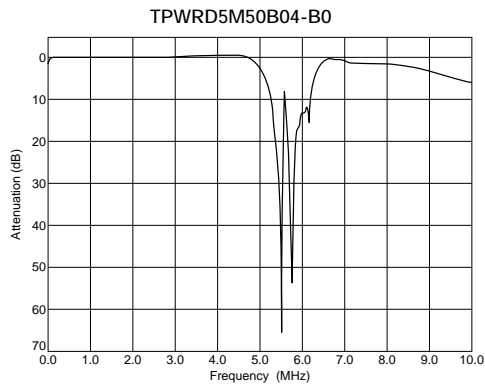
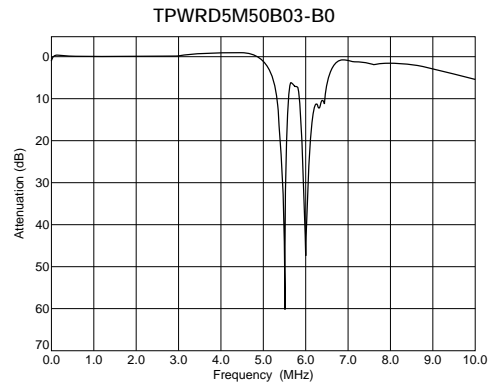
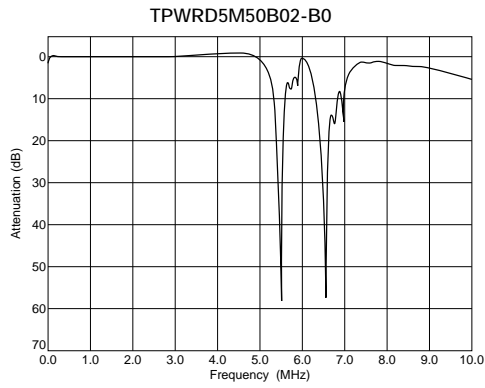

CERAFIL® (Filters/Traps/Discriminators) for Audio/Visual Equipment



Ceramic Trap TPTRD Series

Ceramic trap TPTRD_B series consist of 3 wafers with 3 trap frequencies. Recommended for Multi standard sets.

■ Features

1. Good performance of attenuation
2. Space saving for Multi set
3. Three-terminals type

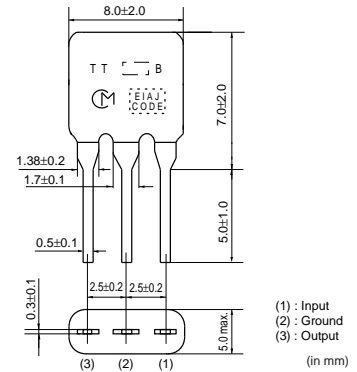

Part Number	Nominal Center Frequency (fn1) (MHz)	Nominal Center Frequency (fn2) (MHz)	Nominal Center Frequency (fn3) (MHz)	Attenuation (at fn1) (dB)	Attenuation (at fn2) (dB)	Attenuation (at fn3) (dB)	30dB Attenuation BW (fn1) (kHz)
TPTRD5M50B01-B0	5.500	6.000	6.500	30 min.	30 min.	30 min.	50 min.

The order quantity should be an integral multiple of the "Minimum Quantity" shown in the package page.

■ Test Circuit

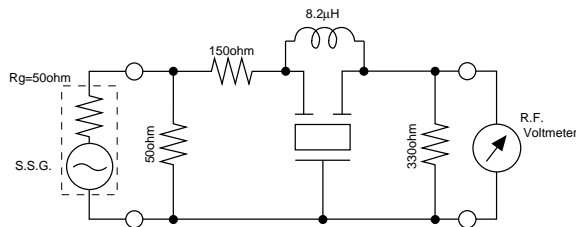

■ Frequency Characteristics

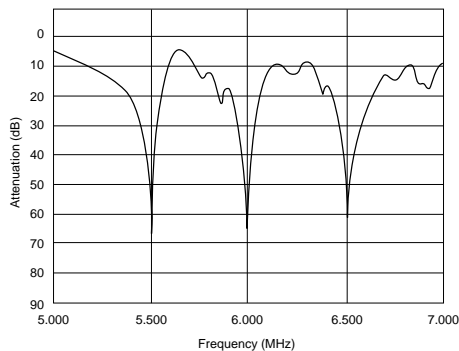

■ Frequency Characteristics (Spurious)

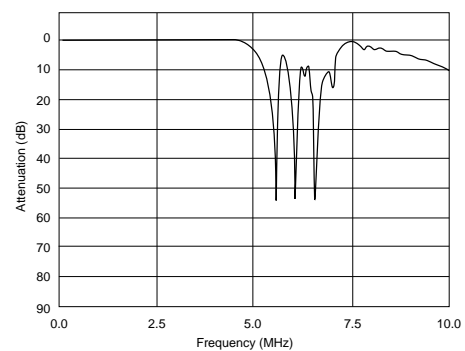

CERAFIL® (Filters/Traps/Discriminators) for Audio/Visual Equipment



Ceramic Discriminator 10.7MHz Ultra Thin Chip Type CDSCB Series

CDSCB10M7 series forms a resonator on a piezoelectric ceramic substrate. In combination with ICs, this type obtains stable demodulation characteristics in a wide bandwidth.
They have 1.0mm max. thickness and small mounting area (4.5x2.0mm).

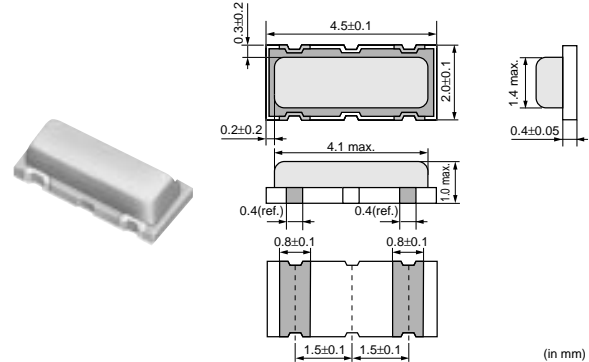

■ Features

1. Compact and high reliability and recommended for automotive applications.
2. Can be combined with various ICs. The IC is determined by the last number in the part number.
3. Stable demodulation characteristics can be obtained without adjustment.
4. Stable temperature characteristics
5. Recommended for Pb free soldering

Part Number	Center Frequency (fo) (MHz)	Recovered Audio 3dB BW (kHz)	Recovered Audio Output (mV)	Distortion (%)	IC	Detection Method
CDSCB10M7GA105A-R0	10.700 ±30kHz	220 min.	110 min.	1.5 max.	TEA5757HL	Quadrature
CDSCB10M7GA113-R0	10.700 ±30kHz	300 min.	110 min.	1.0 max.	TA2154FN	Quadrature
CDSCB10M7GA119-R0	10.700 ±30kHz	500 min.	75 min.	1.0 max.	TRF6901	Quadrature
CDSCB10M7GA121-R0	10.700 ±30kHz	390 min.	80 min.	1.0 max.	LV23100V	Quadrature
CDSCB10M7GF072-R0	10.700 (fn)	fn±150 min.	130 min.	2.0 max.	TA31161	Quadrature
CDSCB10M7GF107-R0	10.700 (fn)	fn±80 min.	52 min.	3.0 max.	TA31272F	Quadrature
CDSCB10M7GF109-R0	10.700 (fn)	fn±100 min.	170 min.	3.0 max.	TK14588V	Quadrature

(fn) means nominal center frequency.

The order quantity should be an integral multiple of the "Minimum Quantity" shown in the package page.

■ Standard Center Frequency Rank Code

CODE	30kHz Step	25kHz Step
D	10.64MHz±30kHz	10.650MHz±25kHz
B	10.67MHz±30kHz	10.675MHz±25kHz
A	10.70MHz±30kHz	10.700MHz±25kHz
C	10.73MHz±30kHz	10.725MHz±25kHz
E	10.76MHz±30kHz	10.750MHz±25kHz
Z	Combination A,B,C,D,E	
M	Combination A,B,C	

Continued on the following page. ↗

Continued from the preceding page.

Standard Land Pattern Dimensions

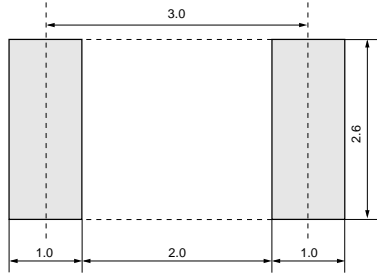

(in mm)

Test Circuit

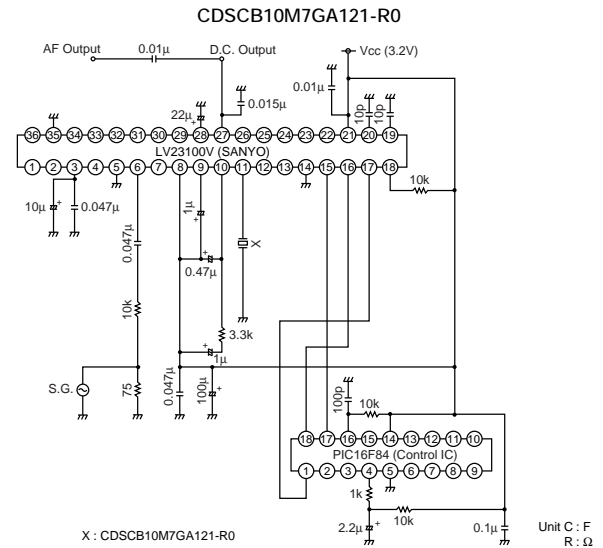
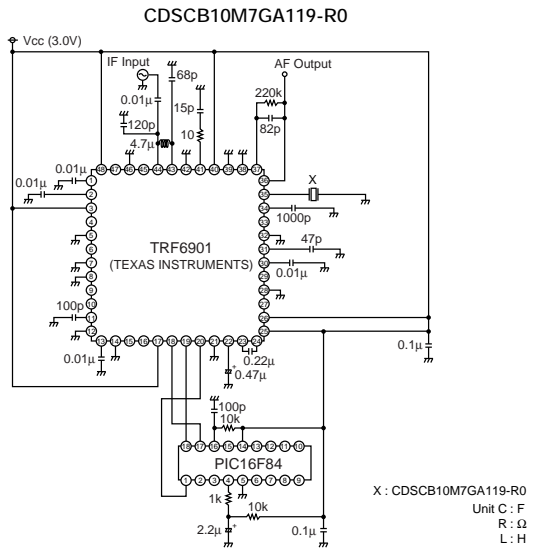
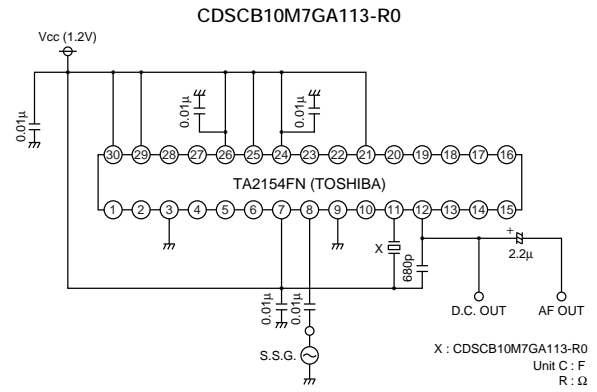
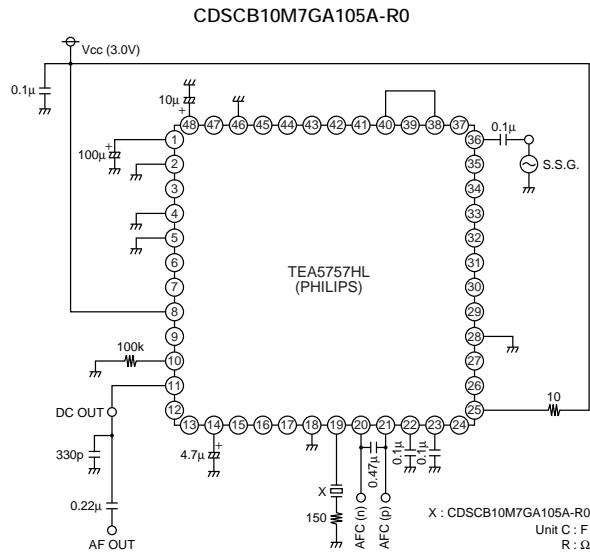

Continued on the following page.

Continued from the preceding page.

Test Circuit

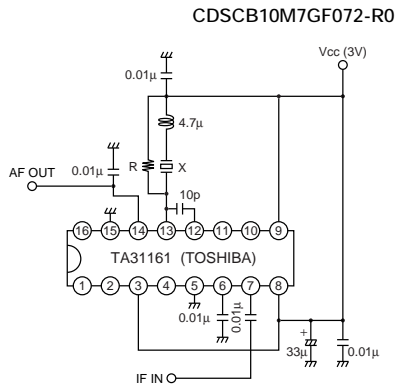

X : CDSCB10M7GF072-R0
R : 820
Unit C : F
R : Ω
L : H

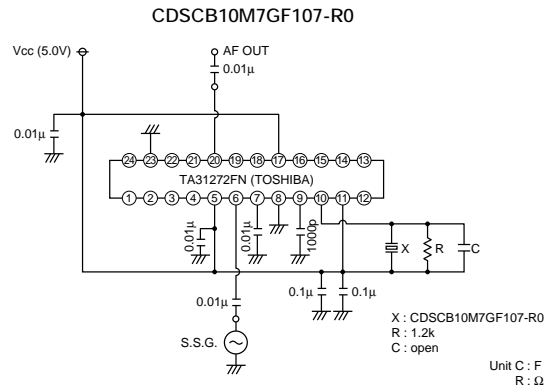

X : CDSCB10M7GF107-R0
R : 1.2k
C : open
Unit C : F
R : Ω

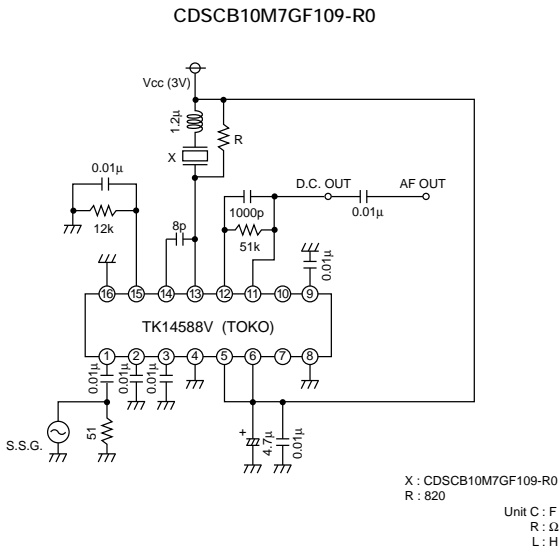

X : CDSCB10M7GF109-R0
R : 820
Unit C : F
R : Ω
L : H

Frequency Characteristics

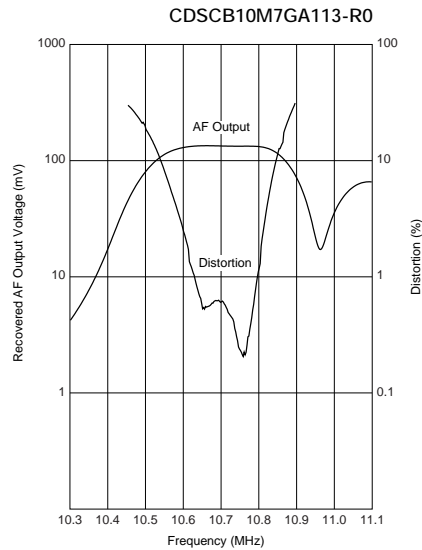
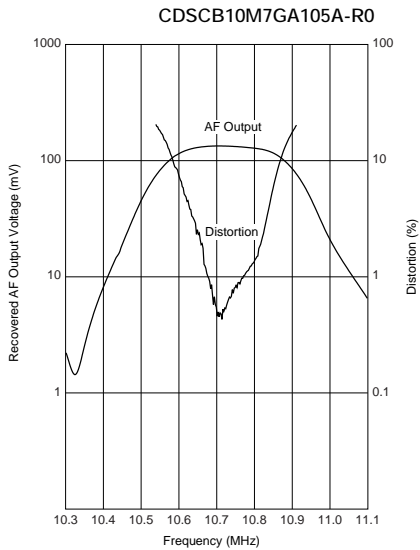

Continued on the following page. ↗

Continued from the preceding page.

Frequency Characteristics

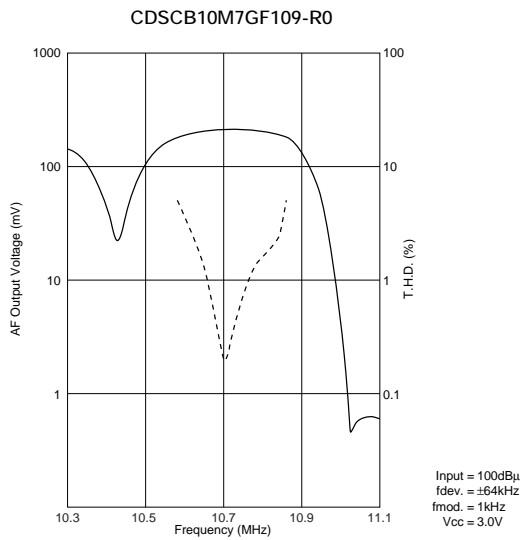
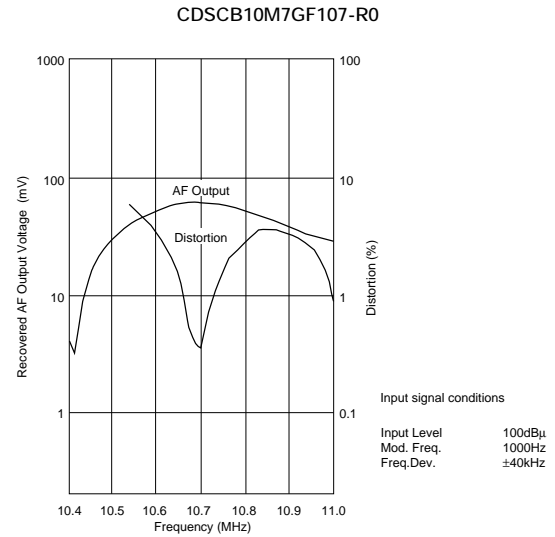
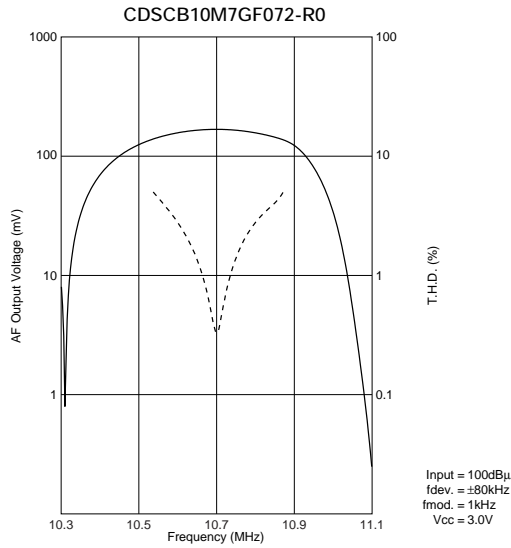
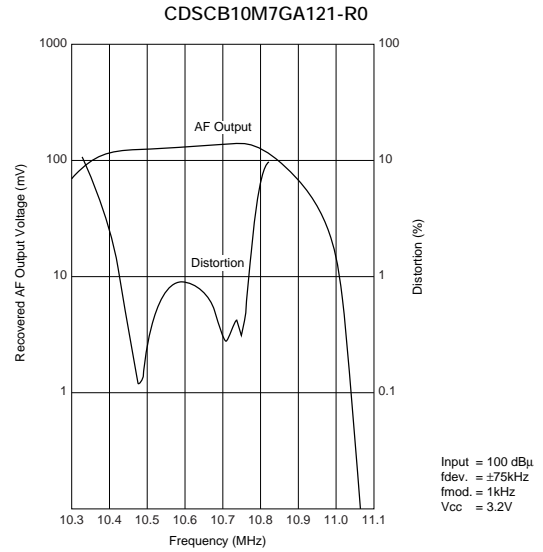
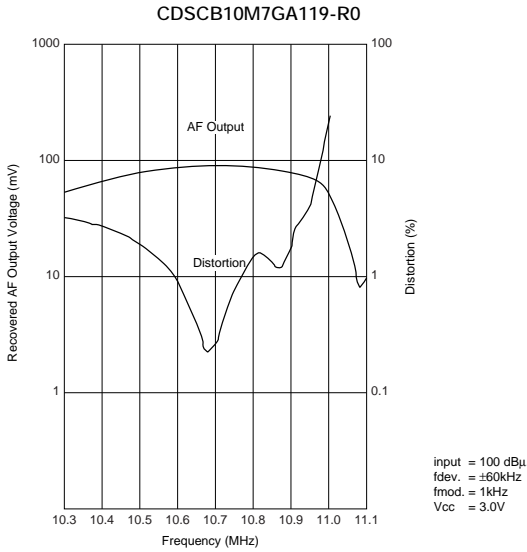

CERAFIL® (Filters/Traps/Discriminators) for Audio/Visual Equipment



Ceramic Discriminator 10.7MHz Standard Lead Type CDALA Series

CDALA10M7 series forms a resonator on a piezoelectric ceramic substrate. In combination with ICs, this type obtains stable demodulation characteristics in wide bandwidths.

■ Features

1. Compact and excellent mechanical strength
2. Can be combined with various ICs. The IC is determined by the last number in the part number.
3. Stable demodulation characteristics can be obtained without adjustment.
4. Stable temperature characteristics
5. We recommend combination: ceramic discriminator CDALA10M7 series and "CERAFIL" SFELA10M7 of the same frequency rank.

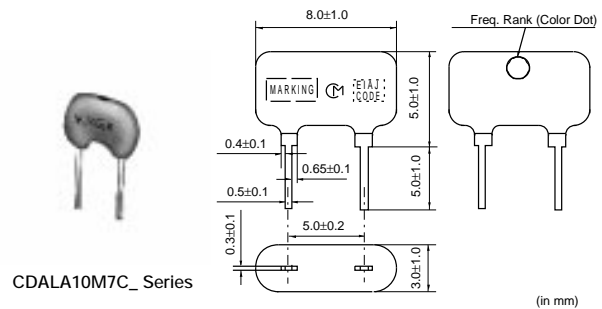
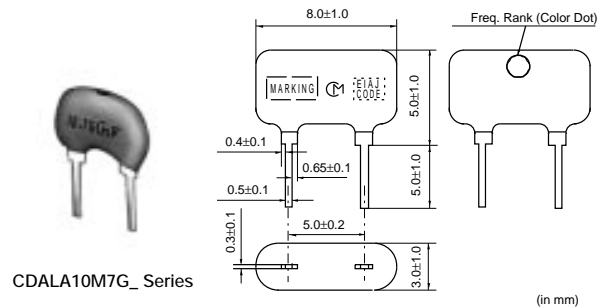

Part Number	Center Frequency (fo) (MHz)	Recovered Audio 3dB BW (kHz)	Recovered Audio Output (mV)	Distortion (%)	IC	Detection Method
CDALA10M7GA001-B0	10.700 ±30kHz	-	-	0.6 max.	CX20029	Quadrature
CDALA10M7GA016-B0	10.700 ±30kHz	300 min.	within60 to 90mV	0.9 max.	TA8122F	Quadrature
CDALA10M7GA018-B0	10.700 ±30kHz	300 min.	within60 to 90mV	0.9 max.	TA8132N	Quadrature
CDALA10M7GA046-B0	10.700 ±30kHz	330 min.	280 min.	1.0 max.	LA1832	Quadrature
CDALA10M7GA048-B0	10.700 ±30kHz	400 min.	700 min.	1.0 max.	LA1835	Quadrature
CDALA10M7GA092-B0	10.700 ±30kHz	300 min.	60 min.	1.0 max.	TA2132P	Quadrature
CDALA10M7CA001-B0	10.700 ±30kHz	242 min.	35 min.	1.0 max.	CX20091	Quadrature
CDALA10M7CA005A-B0	10.700 ±30kHz	100 min.	600 min.	6.0 max.	LA7770	Quadrature
CDALA10M7CA040-B0	10.700 ±30kHz	130 min.	40 min.	0.7 max.	TEA5710	Quadrature

The order quantity should be an integral multiple of the "Minimum Quantity" shown in the package page.
CDALA10M7GA018-B0: Color dot is different from standard series.

■ Standard Center Frequency Rank Code

CODE	30kHz Step	25kHz Step	Color Code
D	10.64MHz±30kHz	10.650MHz±25kHz	Black
B	10.67MHz±30kHz	10.675MHz±25kHz	Blue
A	10.70MHz±30kHz	10.700MHz±25kHz	Red
C	10.73MHz±30kHz	10.725MHz±25kHz	Orange
E	10.76MHz±30kHz	10.750MHz±25kHz	White
Z	Combination A,B,C,D,E		
M	Combination A,B,C		

■ Test Circuit

CDALA10M7GA001-B0

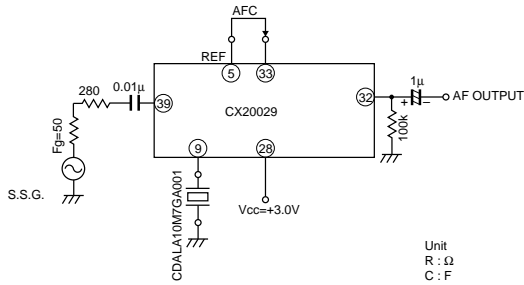

Unit
R : Ω
C : F

CDALA10M7GA016-B0

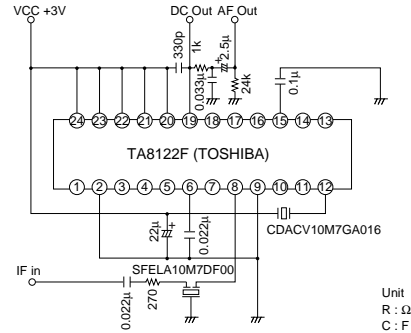

Unit
R : Ω
C : F

CDALA10M7GA018-B0

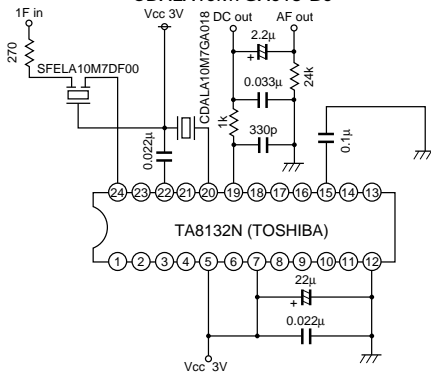

Unit
R : Ω
C : F

CDALA10M7GA046-B0

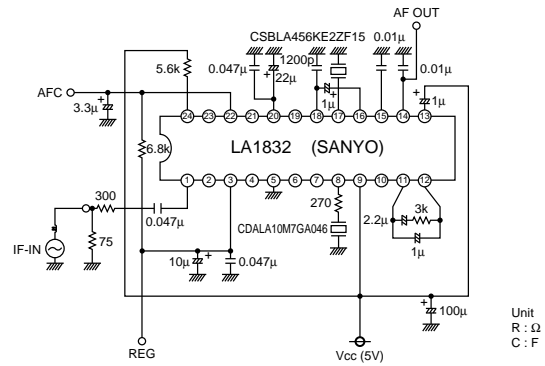

Unit
R : Ω
C : F

CDALA10M7GA048-B0

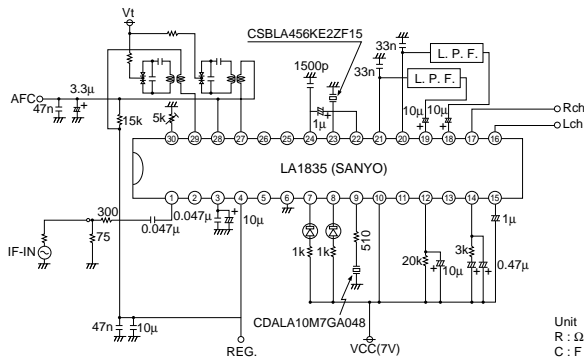

Unit
R : Ω
C : F

CDALA10M7GA092-B0

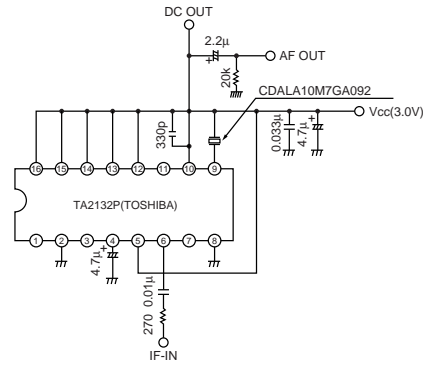

Unit
R : Ω
C : F

CDALA10M7CA001-B0

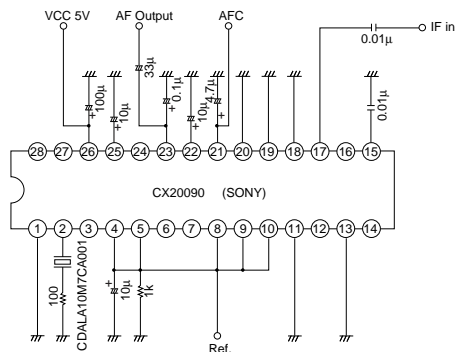

Unit
R : Ω
C : F

CDALA10M7CA005A-B0

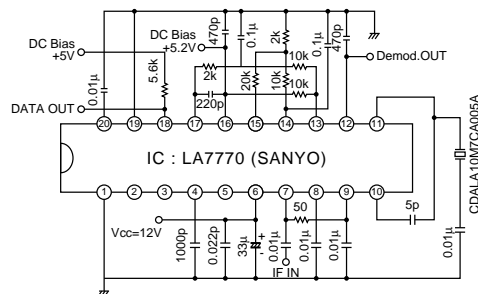

Unit
R : Ω
C : F

Continued on the following page.

Continued from the preceding page.

Test Circuit

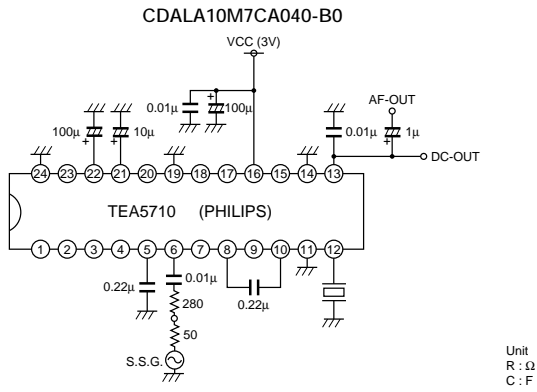

Unit
R : Ω
C : F

Frequency Characteristics

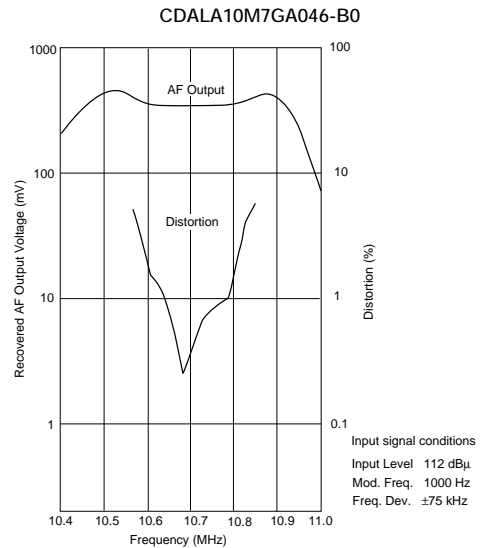
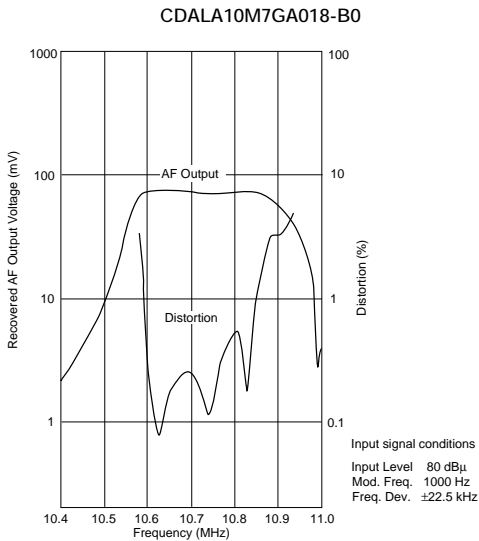
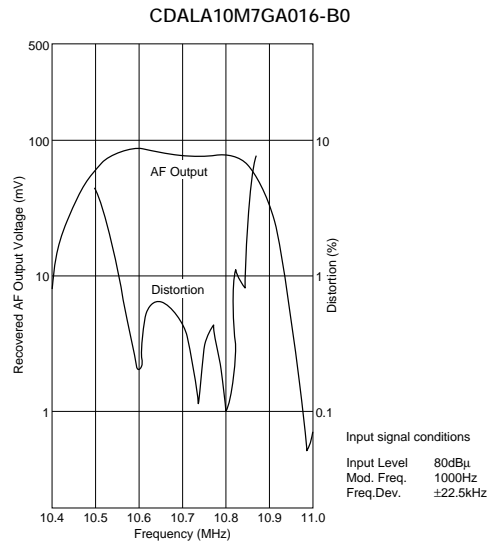
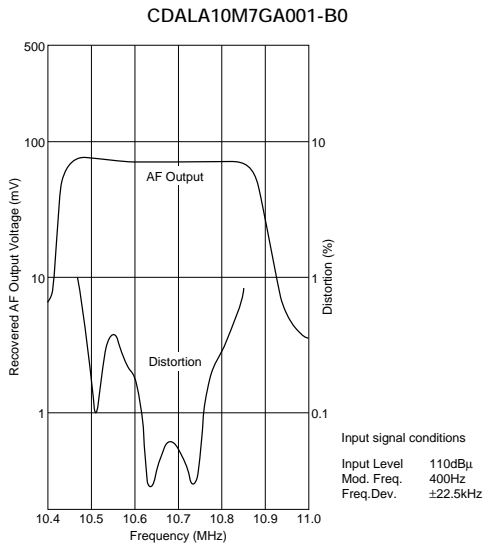

Continued on the following page. ↗

Continued from the preceding page.

Frequency Characteristics

CDALA10M7GA048-B0

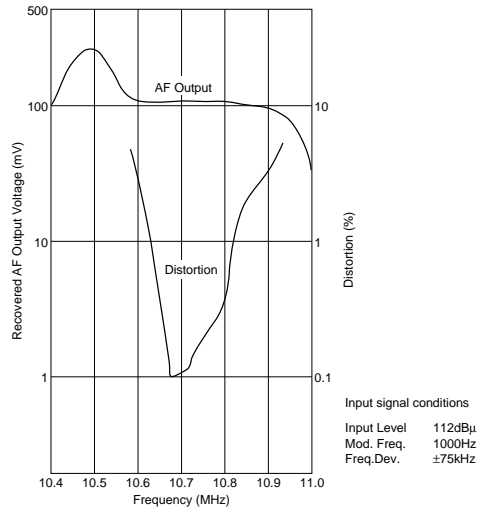

CDALA10M7GA092-B0

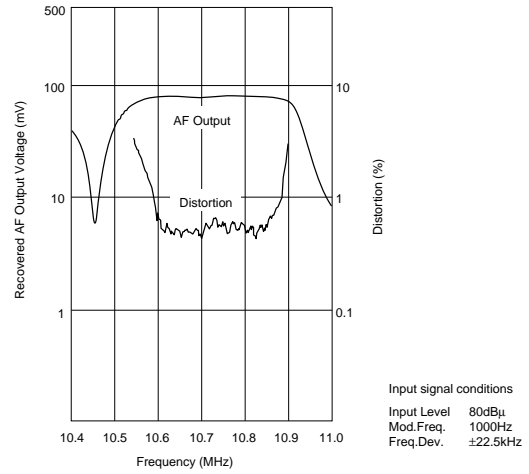

CDALA10M7CA001-B0

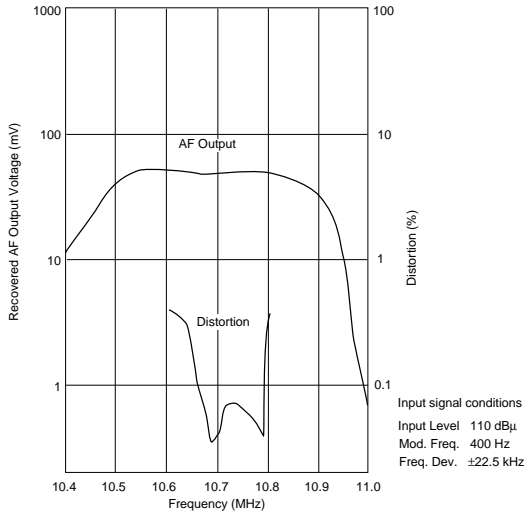

CDALA10M7CA005A-B0

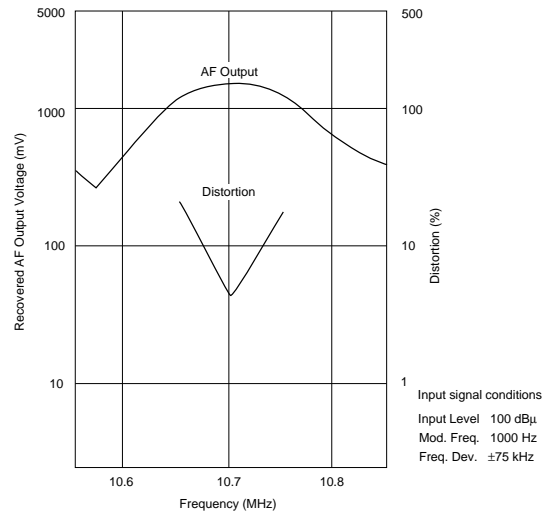

CDALA10M7CA040-B0

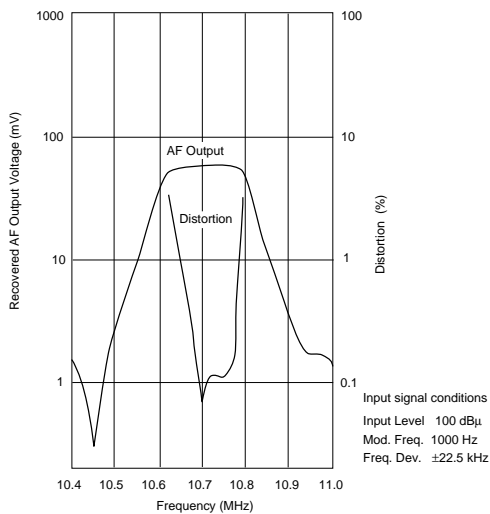

Ceramic Discriminator 10.7MHz Applied IC Reference Table

Please see following table for reference applied IC.

If you can not find IC part number seeking, please contact our sales representative.

ex. : CDALA10M7GA016-B0

Suffix Number

CDSCB10M7GA105A-R0

Suffix Number

IC Manufacturer	IC Part Number	Suffix Number
ATMEL	U2501B	028
	U2765B	095
	U4313B	081
	U4490B	034V
	U829B	025
INFINEON	TDA1576T	051
	TDA6160X	038
	TDA6160-2X	044
MATSUSHITA	AN6138SH	097
	AN7004	011
	AN7006S	014A
	AN7007SU	013
MOTOROLA	AN7232	053
	MC13156	049
	MC13158	073
	MC13173	052
NEC	MC3363	087
	μPC1391M	056
PHILIPS	NE604	020
	SA605	042
	SA626	047
	SA636DK	096
	SA639	085
	TBA120U	029
	TBA229-2	021A
	TDA1596T	120
	TDA2557	024
	TEA5591	017
	TEA5592	030
	TEA5594	035
	TEA5710	040
	TEA5712T	055
	TEA5757HL	105A
	TEA5762 / 5757	061
	UAA3220TS	098
RFMD	RF2905	111
	RF2925	104
ROHM	BA1440	019
	BA1448	060
	BA4110	066
	BA4220	041
	BA4230AF	005
	BA4234L	004
	BA4240L	067

IC Manufacturer	IC Part Number	Suffix Number
SAMSUNG	KA22425	089
	KA2244	059
	KA22901	090
	KA2292	063
	KA2295	064
	KA2297	091
	KA2298B	065
	KB22902	103
	S1A0903	118A
	SANYO	LA1150
LA1225M		108A
LA1260		007
LA1805		026
LA1810		022
LA1814M		115
LA1816		015
LA1822		094
LA1823		101
LA1827M		083
LA1830		037
LA1831		043
LA1832 / M		046
LA1833		086
LA1835 / M		048
LA1838 / M		079
LA7770		023
LV23000M	114	
LV23100V	121	
SONY	CX1691M	078
	CX-20029	001
	CX-20076	002
	CXA1030P	012
	CXA1111	093
	CXA1238	027
	CXA1238N	027N
	CX1343M	032
	CXA1376AM	054
	CXA1538M / N / S	069
	CXA1611	075
CXA1619B	117	
CXA1991N	068	
CX3067M	076	
T. I.	TRF6901	119

Continued on the following page. 

Ceramic Discriminator 10.7MHz Applied IC Reference Table

Continued from the preceding page.

IC Manufacturer	IC Part Number	Suffix Number
TOKO	TK14570L	122
	TK14581	062
	TK14583V	112
	TK14588V	109
TOSHIBA	TA2003	031
	TA2007	033
	TA2008A / AN	045
	TA2022	050
	TA2029	036
	TA2046	058
	TA2057	057
	TA2099N	082
	TA2104AFN	080
	TA2104F	080A
	TA2111N / F / FN	077
	TA2132	092
	TA2132BP	092D
	TA2142FN	102
	TA2149AN	100A
	TA2149N	100
	TA2154FN	113
	TA2159F	116
	TA31161	072
	TA31272F	107
	TA7130P	009
	TA7303P	008
	TA7640AP	006
	TA7765AF	071
	TA8122AN / AF	016
	TA8132AN / AF	018
TA8186	039	
TA8721ASN	088	

Ceramic Discriminator 10.7MHz Applied Circuit

■ LA1140 (Automotive Radio)

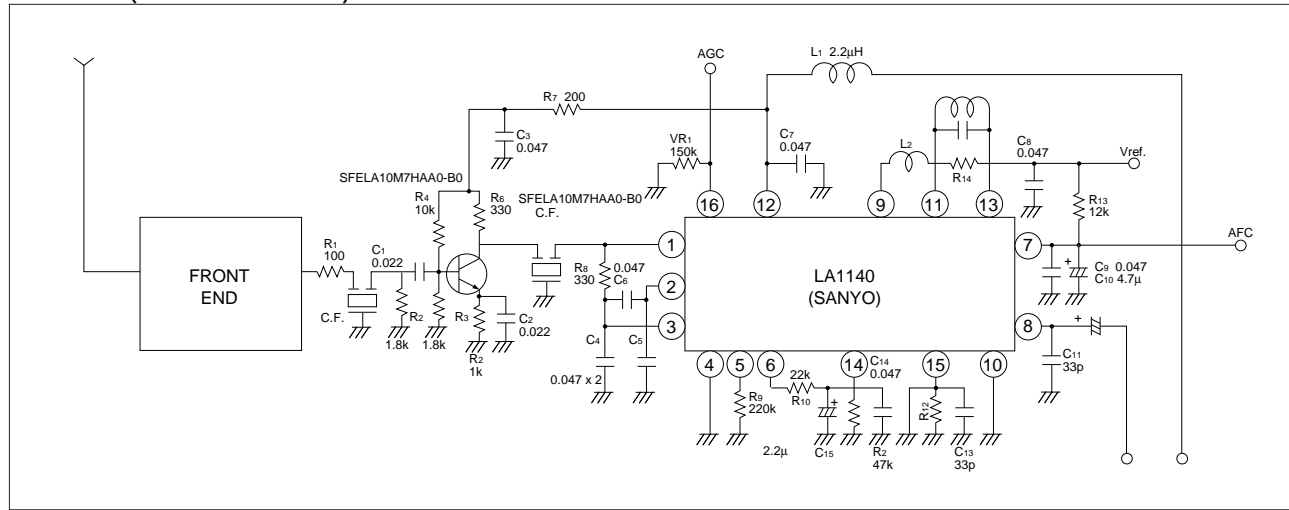

■ CXA1019M (Radio)

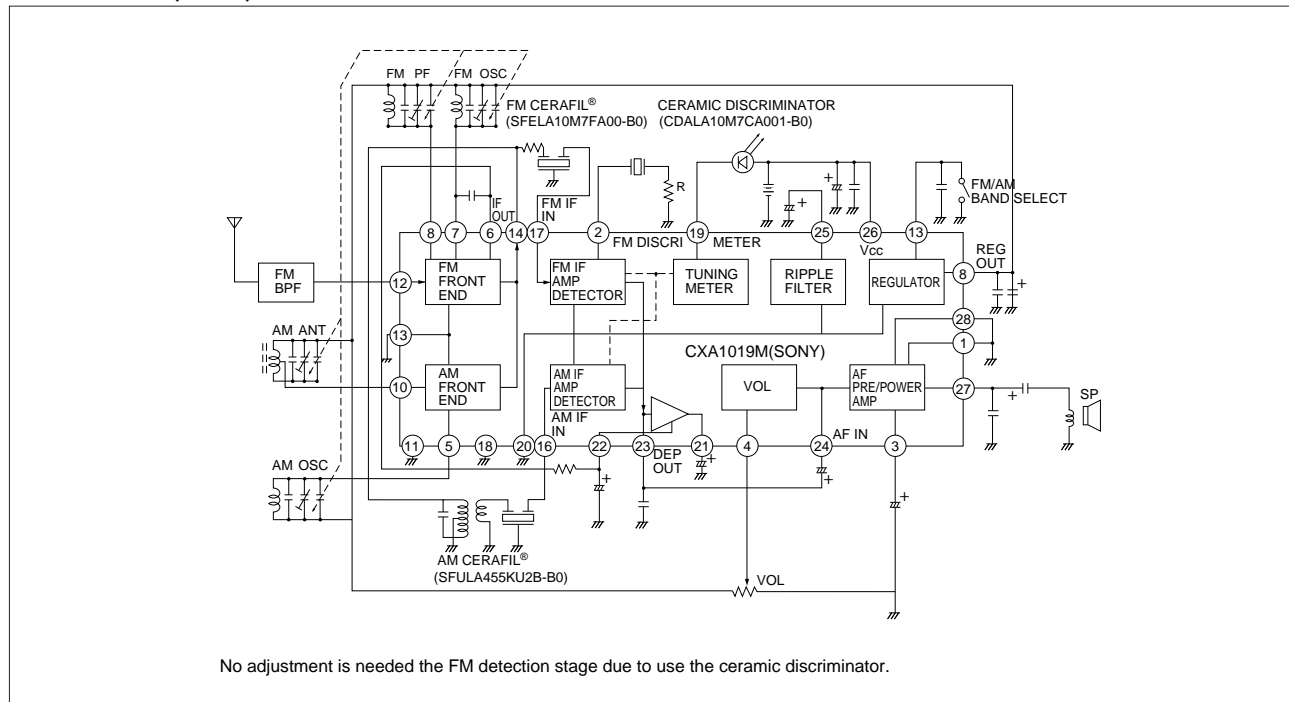

No adjustment is needed the FM detection stage due to use the ceramic discriminator.

Continued on the following page. ↗

Ceramic Discriminator 10.7MHz Applied Circuit

Continued from the preceding page.

TA8122F (Radio)

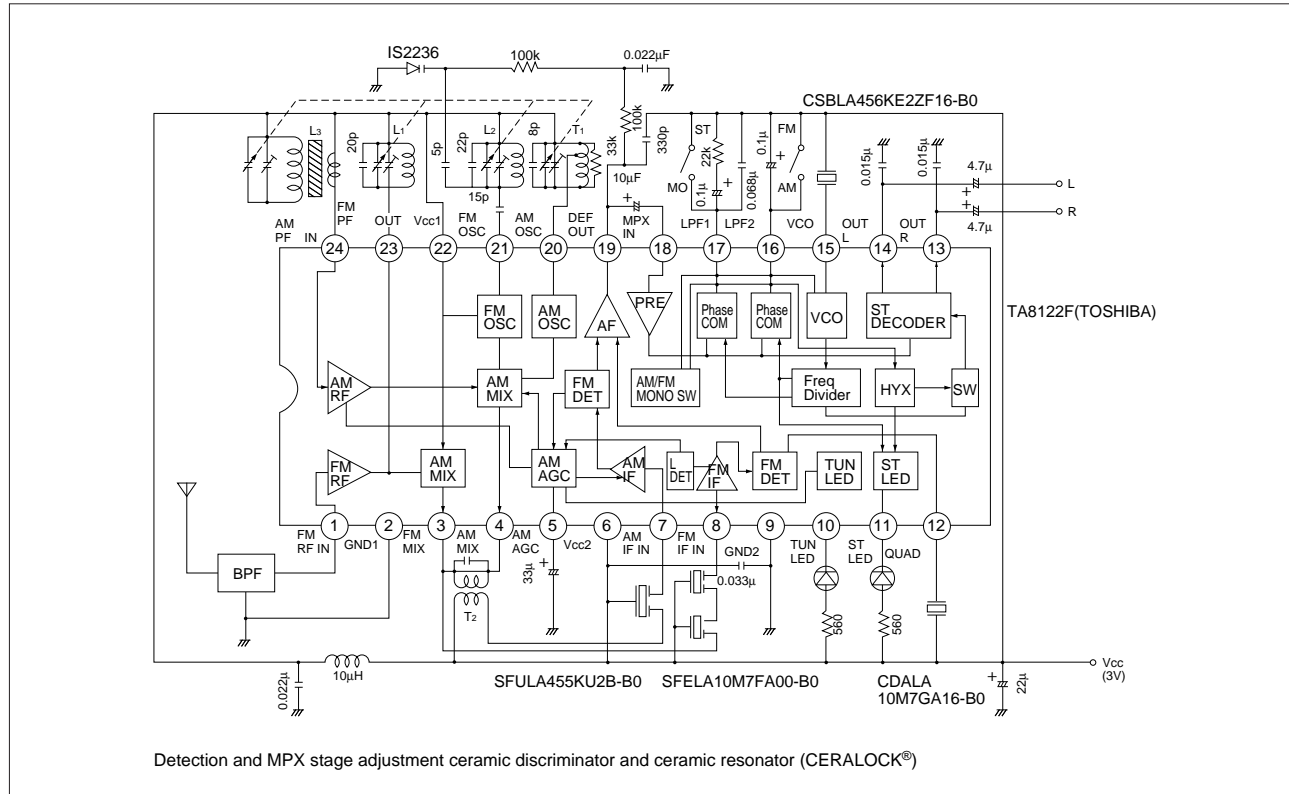

CERAFIL® (Filters/Traps/Discriminators) for Audio/Visual Equipment



Ceramic Discriminator 3.5-6.5MHz Wide Bandwidth Type CDSRH Series

Ceramic discriminator CDSRH series is a wide band, low profile type using thickness shear mode vibration.

■ Features

1. Low profile 8.0mm type
2. Suitable for Multi-sound Broadcasting system
3. Two-terminals type and three-terminals type are available.



CDSRH_EK Series

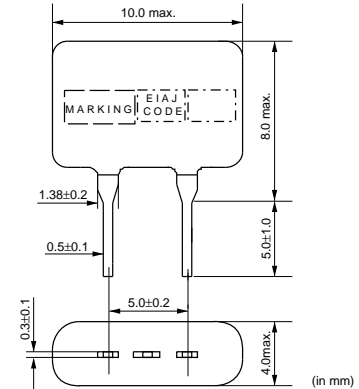

CDSRH_CK Series

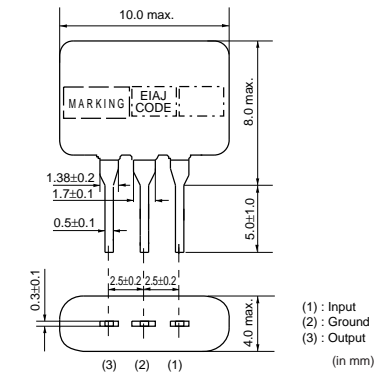

Part Number	Nominal Center Frequency (fn) (MHz)	Recovered Audio 3dB BW (kHz)	Recovered Audio Output Voltage (at fn) (mV)	Distortion (%)	IC	Detection Method
CDSRH4M50EK020-B0	4.500	fn±80 min.	245 min.	1.0 max.	LA7550/7555	Quadrature
CDSRH4M50EK023-B0	4.500	fn±60 min.	230 min.	2.5 max.	M51496P	Quadrature
CDSRH4M50EK035-B0	4.500	fn±55 min.	240 min.	1.0 max.	LA7680/7681	Quadrature
CDSRH4M50EK049-B0	4.500	fn±100 min.	220 min.	1.0 max.	LA7577	Quadrature
CDSRH4M50EK060-B0	4.500	fn±90 min.	90 min.	1.0 max.	M52318SP	Quadrature
CDSRH4M50EK069-B0	4.500	fn±60 min.	320 min.	1.5 max.	TA8701N	Quadrature
CDSRH4M50EK070-B0	4.500	fn±50 min.	65 min.	1.5 max.	M52007FP	Quadrature
CDSRH5M50EK023-B0	5.500	fn±45 min.	220 min.	1.0 max.	M51496P	Quadrature
CDSRH5M50EK035-B0	5.500	fn±80 min.	350 min.	1.0 max.	LA7680/7681	Quadrature
CDSRH5M50EK049-B0	5.500	fn±60 min.	500 min.	1.0 max.	LA7577	Quadrature
CDSRH5M50EK054-B0	5.500	fn±100 min.	300 min.	1.2 max.	TDA3857	Quadrature
CDSRH5M50EK060-B0	5.500	fn±70 min.	190 min.	1.5 max.	M52318SP	Quadrature
CDSRH5M74EK054-B0	5.742	fn±90 min.	340 min.	1.2 max.	TDA3857	Quadrature
CDSRH6M00EK049-B0	6.000	fn±60 min.	500 min.	1.0 max.	LA7577	Quadrature
CDSRH6M00EK054-B0	6.000	fn±90 min.	340 min.	1.5 max.	TDA3857	Quadrature
CDSRH6M00EK060-B0	6.000	fn±60 min.	180 min.	2.5 max.	M52318SP	Quadrature
CDSRH6M50EK020-B0	6.500	fn±110 min.	350 min.	1.2 max.	LA7550/7555	Quadrature
CDSRH6M50EK049-B0	6.500	fn±60 min.	500 min.	1.0 max.	LA7577	Quadrature
CDSRH6M50EK054-B0	6.500	fn±90 min.	340 min.	1.5 max.	TDA3857	Quadrature
CDSRH6M50EK060-B0	6.500	fn±60 min.	160 min.	2.5 max.	M52318SP	Quadrature
CDSRH4M50CK020-B0	4.500	fn±50 min.	280 min.	2.0 max.	μPC1382C	Quadrature
CDSRH4M50CK026-B0	4.500	fn±40 min.	70 min.	1.2 max.	LA7530	Quadrature
CDSRH4M50CK029-B0	4.500	fn±65 min.	250 min.	1.2 max.	M51365SP	Quadrature
CDSRH4M50CK030-B0	4.500	fn±40 min.	within 130 +30/-20mV	3.0 max.	M51348FP	Quadrature

Continued on the following page.

Continued from the preceding page.

Part Number	Nominal Center Frequency (fn) (MHz)	Recovered Audio 3dB BW (kHz)	Recovered Audio Output Voltage (at fn) (mV)	Distortion (%)	IC	Detection Method
CDSRH5M50CK026-B0	5.500	fn±50 min.	500 min.	3.0 max.	LA7530	Quadrature
CDSRH5M50CK029-B0	5.500	fn±70 min.	420 min.	1.5 max.	M51365SP	Quadrature
CDSRH5M50CK030-B0	5.500	fn±55 min.	150 min.	3.0 max.	M51348FP	Quadrature
CDSRH6M00CK026-B0	6.000	fn±50 min.	400 min.	3.0 max.	LA7530	Quadrature
CDSRH6M00CK029-B0	6.000	fn±70 min.	450 min.	1.7 max.	M51365SP	Quadrature
CDSRH6M00CK030-B0	6.000	fn±55 min.	150 min.	3.0 max.	M51348FP	Quadrature
CDSRH6M50CK020-B0	6.500	fn±60 min.	480 min.	2.0 max.	μPC1382C	Quadrature
CDSRH6M50CK026-B0	6.500	fn±35 min.	400 min.	3.0 max.	LA7530	Quadrature
CDSRH6M50CK029-B0	6.500	fn±70 min.	430 min.	2.0 max.	M51365SP	Quadrature

Characteristics shown above is as of 100% Dev.
 Part Numbers are varied with applied IC.
 Please note circuits and specifications are also varied with IC.

Test Circuit

CDSRH4M50EK049-B0

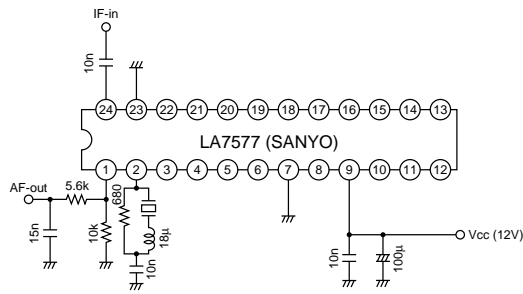

CDSRH4M50CK029-B0

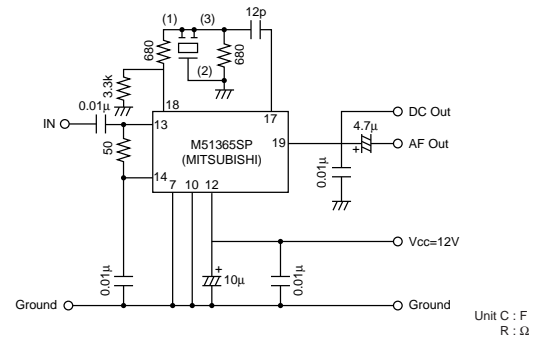

Unit C : F
 R : Ω

Frequency Characteristics

CDSRH4M50EK049-B0

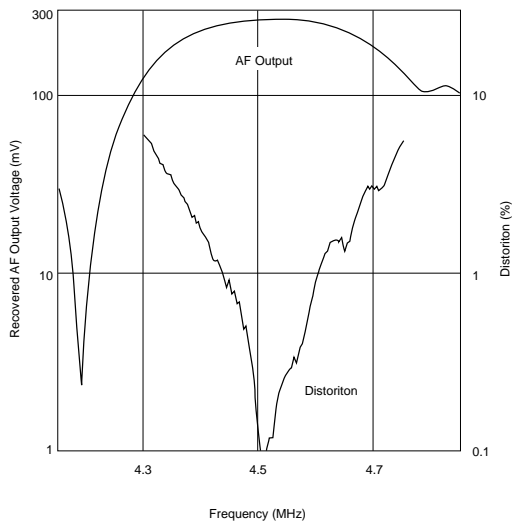

CDSRH4M50CK029-B0

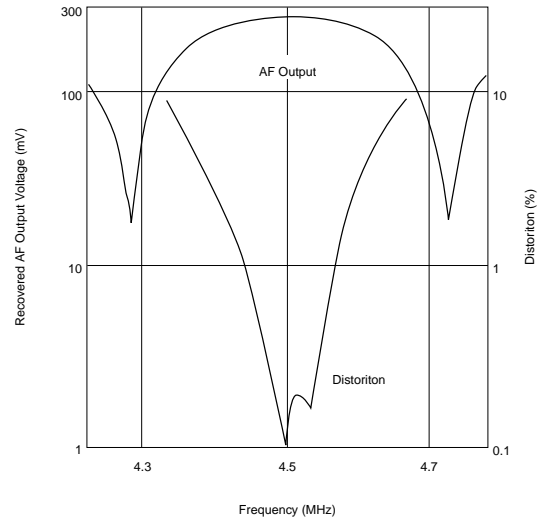

CERAFIL® (Filters/Traps/Discriminators) for Audio/Visual Equipment



Ceramic Discriminator 3.5-6.5MHz Low Profile Type CDSRL Series

Ceramic discriminator CDSRL series is a wide band, low profile type using thickness shear mode vibration.

■ Features

1. Low profile 6.0mm type
2. Suitable for Multi-sound Broadcasting system
3. Two-terminals type and three-terminals type are available.



CDSRL_EK Series

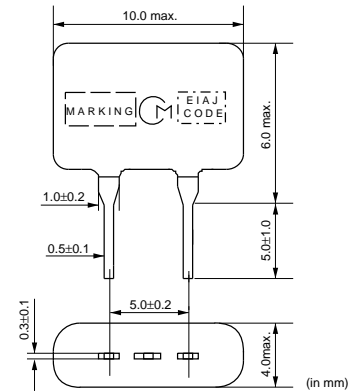

CDSRL_CK Series

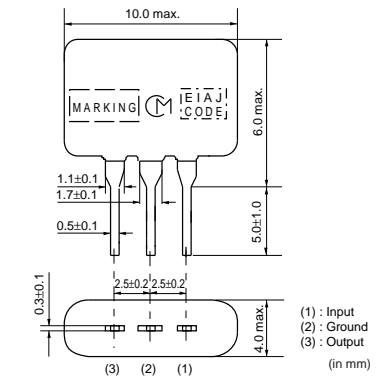

(1) : Input
(2) : Ground
(3) : Output
(in mm)

Part Number	Nominal Center Frequency (fn) (MHz)	Recovered Audio 3dB BW (kHz)	Recovered Audio Output Voltage (at fn) (mV)	Distortion (%)	IC	Detection Method
CDSRL4M50EK020-B0	4.500	fn±80 min.	245 min.	1.0 max.	LA7550/7555	Quadrature
CDSRL5M50EK020-B0	5.500	fn±100 min.	330 min.	1.2 max.	LA7550/7555	Quadrature
CDSRL4M50CK020-B0	4.500	fn±50 min.	280 min.	2.0 max.	μPC1382C	Quadrature
CDSRL4M50CK029-B0	4.500	fn±65 min.	250 min.	1.2 max.	M51365SP	Quadrature
CDSRL4M50CK030-B0	4.500	fn±40 min.	within130 +30/-20mV	3.0 max.	M51348FP	Quadrature
CDSRL5M50CK030-B0	5.500	fn±55 min.	150 min.	3.0 max.	M51348FP	Quadrature
CDSRL6M00CK029-B0	6.000	fn±70 min.	450 min.	1.7 max.	M51365SP	Quadrature
CDSRL6M00CK030-B0	6.000	fn±55 min.	150 min.	3.0 max.	M51348FP	Quadrature
CDSRL6M50CK020-B0	6.500	fn±60 min.	480 min.	2.0 max.	μPC1382C	Quadrature
CDSRL6M50CK026-B0	6.500	fn±35 min.	400 min.	3.0 max.	LA7530	Quadrature

Characteristics shown above is as of 100% Dev.
Part Numbers are varied with applied IC.
Please note circuits and specifications are also varied with IC.

■ Test Circuit

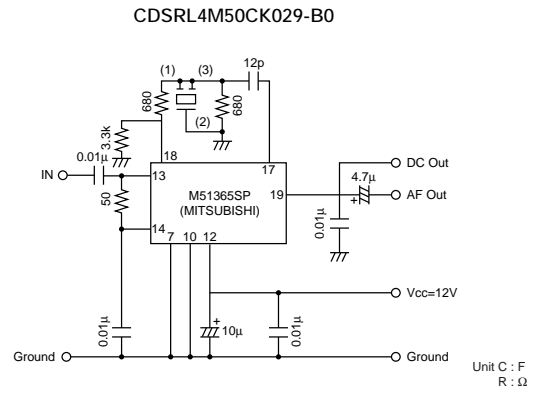
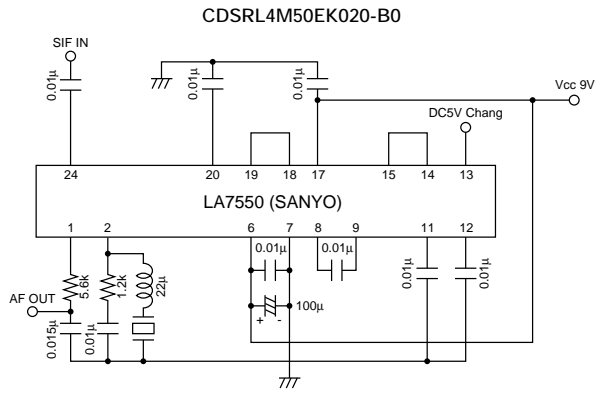

Unit C : F
R : Ω

■ Frequency Characteristics

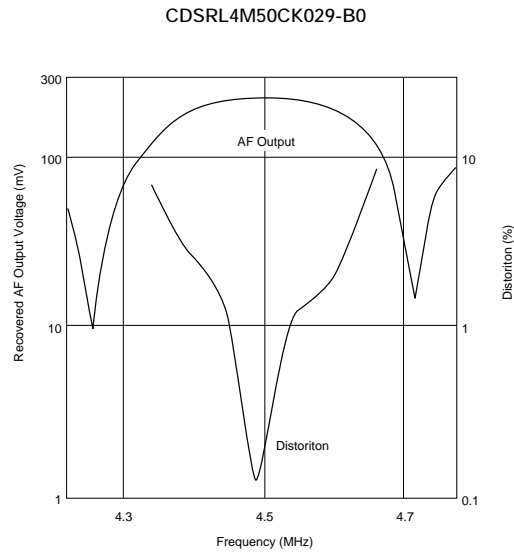
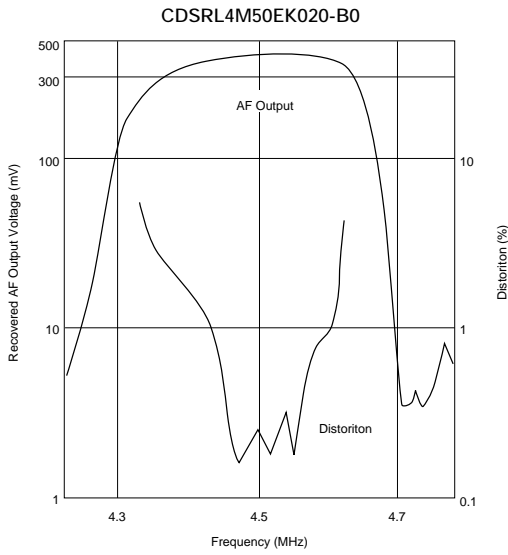

Notice (Soldering and Mounting)

■ CERAFIL® 10.7MHz Chip Type SFECs/SFECd Series

1. Standard Reflow Soldering Condition

(1) Reflow

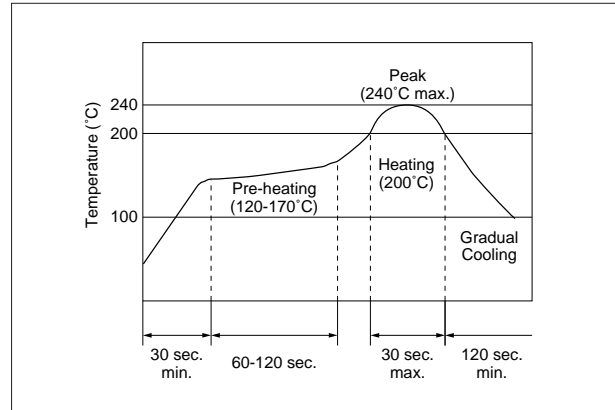

(2) Soldering Iron

Filter shall be soldered at $+280\pm 5^{\circ}\text{C}$ for 3.0 ± 0.5 seconds.
The soldering iron shall not touch the filter while soldering.

2. Wash

The component cannot withstand washing.

■ CERAFIL® 10.7MHz Chip Type SFECV Series

1. Standard Reflow Soldering Condition

(1) Reflow

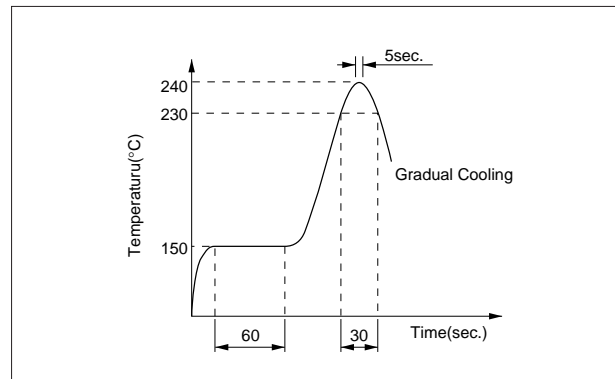

(2) Soldering Iron

Lead terminal is directly contacted with the tip of soldering iron at $+280\pm 5^{\circ}\text{C}$ for 3.0 ± 0.5 seconds.

2. Wash

The component cannot withstand washing.

■ CERAFIL® 10.7MHz Lead Type

The component cannot withstand washing.

Notice (Soldering and Mounting)

■ CERAFIL® 4.5-6.5MHz Chip Type

1. Standard Reflow Soldering Condition

(1) Reflow

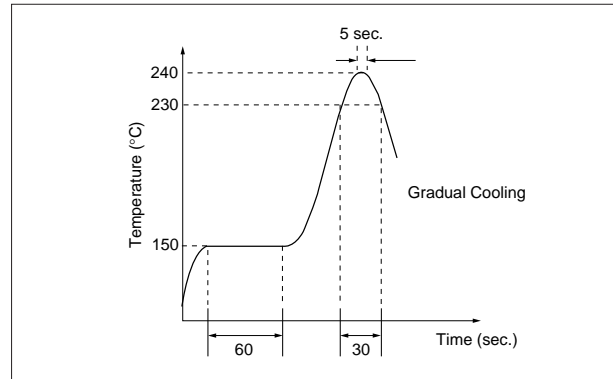

(2) Soldering Iron

Lead terminal is directly contacted with the tip of soldering iron at $+280\pm 5^{\circ}\text{C}$ for 3.0 ± 0.5 seconds.

2. Wash

The component cannot withstand washing.

■ CERAFIL® 3.5-6.5MHz Lead Type

The component cannot withstand washing.

■ CERAFIL® 455kHz Chip Type PFWCC Series

1. Standard Reflow Soldering Condition

(1) Reflow

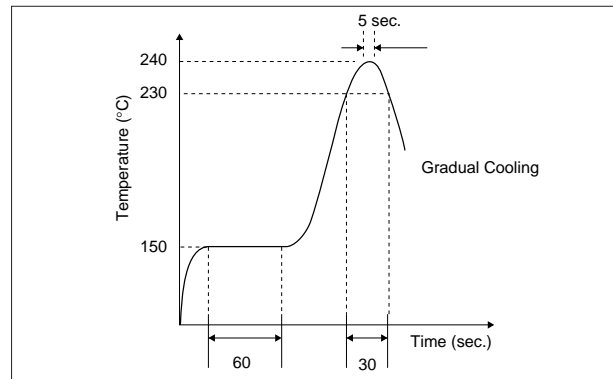

(2) Soldering Iron

Lead terminal is directly contacted with the tip of soldering iron at $+280\pm 5^{\circ}\text{C}$ for 3.0 ± 0.5 seconds.

2. Wash

The component cannot withstand washing.

Continued on the following page. 

Notice (Soldering and Mounting)

☒ Continued from the preceding page.

■ CERAFIL® 455kHz Chip Type SFPCA Series

1. Standard Reflow Soldering Condition

(1) Reflow

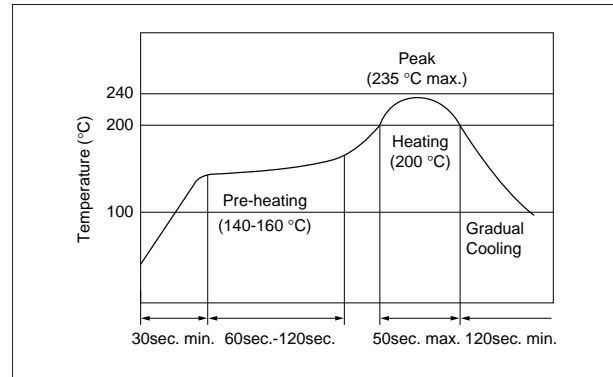

(2) Soldering Iron

Electrode is soldered directly with the tip of soldering iron at $+350\pm 5^{\circ}\text{C}$ for 3 ± 1 seconds.

2. Wash

(1) Cleaning Solvent

CFC alternatives (HCFC Series), Isopropyl Alcohol (IPA), Water (Demineralized Water), Cleaning Water Solution (Cleantrough-750H, Pine Alpha 100S), Silicon (Technocare FRW)

(2) Cleaning Conditions

- Immersion Wash
2 minutes max. in above solvent at $+60^{\circ}\text{C}$ max.
- Shower or Rinse Wash
2 minutes max. in above solvent at $+60^{\circ}\text{C}$ max.

(3) Notice

- When components are immersed in solvent, be sure to maintain the temperature of components below the temperature of solvent.
- Please do not use ultrasonic cleaning.
- Total washing time should be within 4 minutes.
- Please ensure the component is thoroughly evaluated in your application circuit.
- Please do not use chlorine, petroleum and alkali cleaning solvents.
- If you plan to use any other type of solvents, please consult with Murata or Murata representative prior to using.

■ CERAFIL® 455kHz Lead Type

The component cannot withstand washing.

Notice (Soldering and Mounting)

■ Ceramic Trap 4.5-6.5MHz Chip Type

1. Standard Reflow Soldering Condition

(1) Reflow

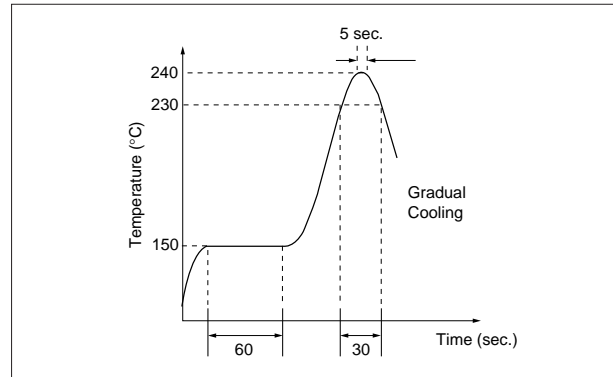

(2) Soldering Iron

Lead terminal is directly contacted with the tip of soldering iron at $+280\pm 5^{\circ}\text{C}$ for 3.0 ± 0.5 seconds.

2. Wash

The component cannot withstand washing.

■ Ceramic Trap 3.5-6.5MHz Lead Type

The component cannot withstand washing.

■ Ceramic Discriminator 10.7MHz Chip Type

1. Standard Reflow Soldering Condition

(1) Reflow

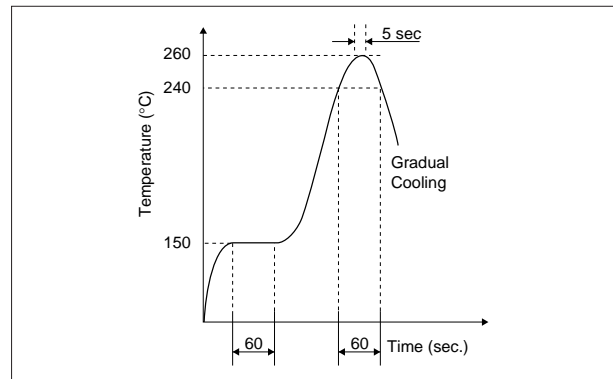

(2) Soldering Iron

Lead terminal is directly contacted with the tip of soldering iron at $+280\pm 5^{\circ}\text{C}$ for 3.0 ± 0.5 seconds.

2. Wash

The component cannot withstand washing.

■ Ceramic Discriminator 10.7MHz Lead Type

The component cannot withstand washing.

■ Ceramic Discriminator 3.5-6.5MHz

The component cannot withstand washing.

Notice (Handling)

■ CERAFIL® 10.7MHz Chip Type SF ECS/SF ECD Series

1. The component will be damaged when an excessive stress is applied.
2. The component may be damaged if excess mechanical stress is applied to it mounted on the printed circuit board.
3. Design layout of components on the PC board to minimize the stress imposed on the warp or flexure of the board.
4. After installing chips, if solder is excessively applied to the circuit board, mechanical stress will cause destruction resistance characteristics to lower. To prevent this, be extremely careful in determining shape and dimension before designing the circuit board diagram.
5. When the positioning claws and pick up nozzle are worn, the load is applied to the chip while positioning is concentrated to one positioning accuracy, etc. Careful checking and maintenance are necessary to prevent unexpected trouble.
6. When correcting chips with a soldering iron, the tip of the soldering iron should not directly touch the chip component. Depending on the soldering conditions, the effective area of terminations may be reduced. The use of solder containing Ag should be done to prevent the electrode erosion.
7. Do not clean or wash the component as it is not hermetically sealed.
8. In case of covering filter with over coat, conditions such as material of resin, cure temperature, and so on should be evaluated carefully.
9. Do not use strong acidity flux, more than 0.2wt% chlorine content, in re-flow soldering.
10. Accurate test circuit values are required to measure electrical characteristics.
It may be a cause of miscorrelation if there is any deviation, especially stray capacitance, from the test circuit in the specification.

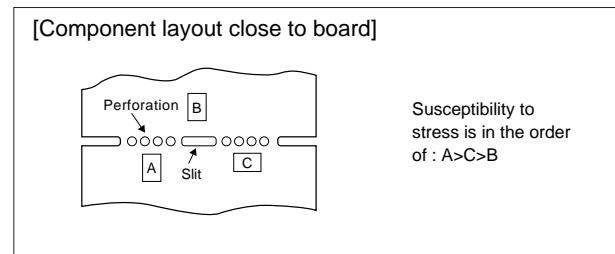

Continued on the following page. 

Notice (Handling)

Continued from the preceding page.

■ CERAFIL® 10.7MHz Chip Type SFECV Series

1. The component will be damaged when an excessive stress is applied.
2. The component may be damaged if excess mechanical stress is applied to it mounted on the printed circuit board.
3. Design layout of components on the PC board to minimize the stress imposed on the warp or flexure of the board.
4. After installing chips, if solder is excessively applied to the circuit board, mechanical stress will cause destruction resistance characteristics to lower. To prevent this, be extremely careful in determining shape and dimension before designing the circuit board diagram.
5. When the positioning claws and pick up nozzle are worn, the load is applied to the chip while positioning is concentrated to one positioning accuracy, etc. Careful checking and maintenance are necessary to prevent unexpected trouble.
6. When correcting chips with a soldering iron, the tip of the soldering iron should not directly touch the chip component. Depending on the soldering conditions, the effective area of terminations may be reduced. the use of solder containing Ag should be done to prevent the electrode erosion.
7. Do not clean or wash the component as it is not hermetically sealed.
8. In case of covering filter with over coat, conditions such as material of resin, cure temperature, and so on should be evaluated carefully.
9. Do not use strong acidity flux, more than 0.2wt% chlorine content, in re-flow soldering.
10. Accurate test circuit values are required to measure electrical characteristics. It may be a cause of mis-correlation if there is any deviation, especially stray capacitance, from the test circuit in the specification.

■ CERAFIL® 10.7MHz Lead Type

1. Do not use this product with bend. The component may be damaged if excess mechanical stress is applied to it mounted on the printed circuit board.
2. The component may be damaged when an excess stress is applied.
3. All kinds of re-flow soldering must not be applied on the component.
4. Do not clean or wash the component as it is not hermetically sealed.
5. Do not use strong acidity flux, more than 0.2wt%

[Component direction]

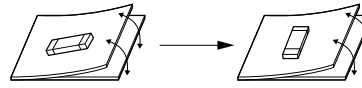

Put the component lateral to the direction in which stress acts.

[Component layout close to board]

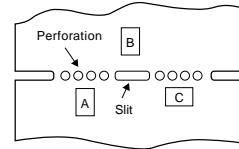

Susceptibility to stress is in the order of : A>C>B

chlorine content, in flow soldering.

6. In case of covering discriminator with over coat, conditions such as material of resin, cure temperature, and so on should be evaluated carefully.
7. Accurate test circuit values are required to measure electrical characteristics. It may be a cause of mis-correlation if there is any deviation, especially stray capacitance, from the test circuit in the specification.

Notice (Handling)

■ CERAFIL® 4.5-6.5MHz Chip Type

1. The component may be damaged if excess mechanical stress is applied to it mounted on the printed circuit board.
2. Design layout of components on the PC board to minimize the stress imposed on the wrap or flexure of the board.
3. After installing chips, if solder is excessively applied to the circuit board, mechanical stress will cause destruction resistance characteristics to lower. To prevent this, be extremely careful in determining shape and dimension before designing the circuit board diagram.
4. When the positioning claws and pick up nozzle are worn, the load is applied to the chip while positioning is concentrated to one positioning accuracy, etc. Careful checking and maintenance are necessary to prevent unexpected trouble.
5. When correcting chips with a soldering iron, the tip of the soldering iron should not directly touch the chip component.
6. Cleaning or washing of the component is not acceptable due to non sealed construction.
7. In case of covering filter with over coat, conditions such as material of resin, cure temperature, and so on should be evaluated carefully.
8. Accurate test circuit values are required to measure electrical characteristics. It may be a cause of miscorrelation if there is any deviation, especially stray capacitance, from the test circuit in the specification.

■ CERAFIL® 3.5-6.5MHz Lead Type

1. Do not use this product with bend. The component may be damaged if excess mechanical stress is applied to it mounted on the printed circuit board.
2. The component may be damaged when an excess stress is applied.
3. All kinds of re-flow soldering must not be applied on the component.
4. Do not clean or wash the component as it is not hermetically sealed.
5. Please contact Murata or Murata representative for soldering condition, in case of using lead free

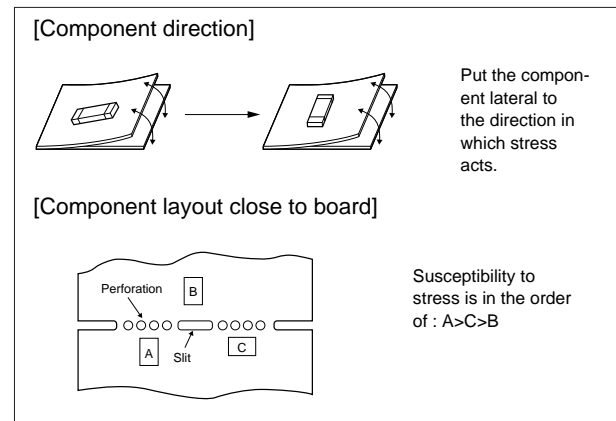

solder.

6. Do not use strong acidity flux, more than 0.2wt% chlorine content, in flow soldering.
7. In case of covering filter with over coat, conditions such as material of resin, cure temperature, and so on should be evaluated carefully.
8. Accurate test circuit values are required to measure electrical characteristics. It may be a cause of miscorrelation if there is any deviation, especially stray capacitance, from the test circuit in the specification.

Notice (Handling)

■ CERAFIL® 455kHz Chip Type PFWCC Series

1. The component may be damaged if excess mechanical stress is applied to it mounted on the printed circuit board.
2. Design layout of components on the PC board to minimize the stress imposed on the warp or flexure of the board.
3. After installing chips, if solder is excessively applied to the circuit board, mechanical stress will cause destruction resistance characteristics to lower. To prevent this, be extremely careful in determining shape and dimension before designing the circuit board diagram.

■ CERAFIL® 455kHz Chip Type SFPCA Series

1. The component will be damaged when an excessive stress is applied.
2. Use coupling capacitors to prevent applying D.C. voltage between input-ground, output-ground of "CERAFIL" as D.C. current may harm the component.
3. In the case that the component is cleaned, confirm that no reliability degradation is created.
4. In case of covering filter with over coat, conditions such as material of resin, cure temperature, and so on should be evaluated carefully.

■ CERAFIL® 455kHz Lead Type

1. Do not use this product with bend. The component may be damaged if excess mechanical stress is applied to it mounted on the printed circuit board.
2. The component will be damaged when an excessive stress is applied.
3. All kinds of re-flow soldering must not be applied on the component.
4. Do not clean or wash the component as it is not hermetically sealed.
5. Do not use strong acidity flux, more than 0.2wt% chlorine content, in flow soldering.

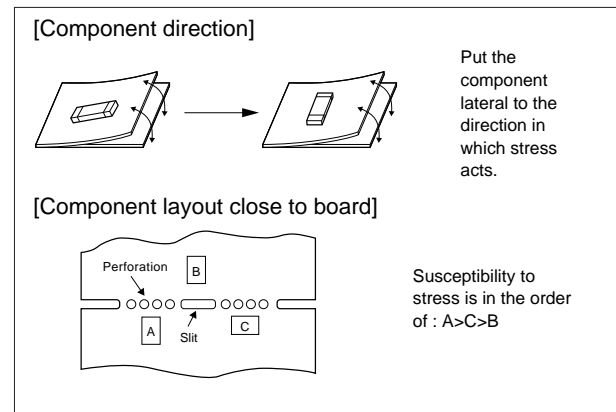

5. Do not use strong acidity flux, more than 0.2wt% chlorine content, in re-flow soldering.
6. The product, packed in the moisture-proof bag (dry pack), is sensitive to moisture. The following treatment is required before applying re-flow soldering, to avoid package cracks or reliability degradation caused by thermal stress. When unpacked, store the component in an atmosphere of below 25 degree C and below 65% R.H., and solder within 48 hours.

6. In case of covering filter with over coat, conditions such as material of resin, cure temperature, and so on should be evaluated carefully.
7. Accurate test circuit values are required to measure electrical characteristics.
It may be a cause of miscorrelation if there is any deviation, especially stray capacitance, from the test circuit in the specification.
8. Use coupling capacitors to prevent applying D.C. voltage between input-ground, output-ground of "CERAFIL" as D.C. current may harm the component.

Notice (Handling)

■ Ceramic Trap 4.5-6.5MHz Chip Type

1. The component may be damaged if excess mechanical stress is applied to it mounted on the printed circuit board.
2. Design layout of components on the PC board to minimize the stress imposed on the wrap or flexure of the board.
3. After installing chips, if solder is excessively applied to the circuit board, mechanical stress will cause destruction resistance characteristics to lower. To prevent this, be extremely careful in determining shape and dimension before designing the circuit board diagram.
4. When the positioning claws and pick up nozzle are worn, the load is applied to the chip while positioning is concentrated to one positioning accuracy, etc. Careful checking and maintenance are necessary to prevent unexpected trouble.
5. When correcting chips with a soldering iron, the tip of the soldering iron should not directly touch the chip component.
6. Cleaning or washing of the component is not acceptable due to non sealed construction.
7. In case of covering filter with over coat, conditions such as material of resin, cure temperature, and so on should be evaluated carefully.
8. Accurate test circuit values are required to measure electrical characteristics. It may be a cause of miscorrelation if there is any deviation, especially stray capacitance, from the test circuit in the specification.

■ Ceramic Trap 3.5-6.5MHz Lead Type

1. Do not use this product with bend. The component may be damaged if excess mechanical stress is applied to it mounted on the printed circuit board.
2. The component may be damaged when an excess stress is applied.
3. All kinds of re-flow soldering must not be applied on the component.
4. Do not clean or wash the component as it is not hermetically sealed.
5. Please contact Murata or Murata representative for soldering condition, in case of using lead free

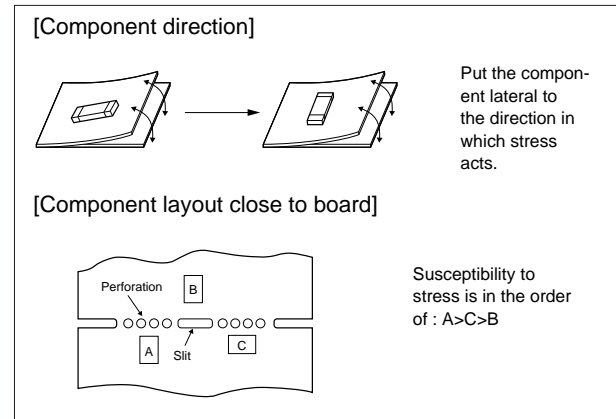

solder.

6. Do not use strong acidity flux, more than 0.2wt% chlorine content, in flow soldering.
7. In case of covering filter with over coat, conditions such as material of resin, cure temperature, and so on should be evaluated carefully.
8. Accurate test circuit values are required to measure electrical characteristics. It may be a cause of miscorrelation if there is any deviation, especially stray capacitance, from the test circuit in the specification.

Notice (Handling)

■ Ceramic Discriminator 10.7MHz Chip Type

1. The component mounted on the PCB may be damaged if excess mechanical stress is applied.
2. Layout the components on the PCB to minimize the stress imposed by the warp or flexure of the board.
3. After installing components, if solder is excessively applied to the circuit board, mechanical stress will cause destruction resistance characteristics to be lower. To prevent this, be extremely careful in determining shape and dimension before designing the circuit board diagram.
4. When the positioning claw or pick up nozzle are worn, the excess load is applied to the components while positioning or placing are performed. Careful checking and maintenance are necessary to prevent unexpected trouble.
5. When correcting component's position with a soldering iron, the tip of the soldering iron should not directly touch the chip component. Depending on the soldering conditions, the effective area of terminations may be reduced. The use of solder containing Ag should be considered to prevent the electrode erosion.
6. Do not clean or wash the component as it is not hermetically sealed.
7. In case of overcoating the part, coating conditions such as material, curing temperature, and so on must be evaluated deeply.
8. Accurate test circuit values are required to measure electrical characteristics.
It may be a cause of miscorrelation if there is any deviation, especially stray capacitance, from the test circuit in the specification.

■ Ceramic Discriminator 10.7MHz Lead Type

1. Do not use this product with bend. The component may be damaged if excess mechanical stress is applied to it mounted on the printed circuit board.
2. The component may be damaged when an excess stress is applied.
3. All kinds of re-flow soldering must not be applied on the component.
4. Do not clean or wash the component as it is not hermetically sealed.
5. Do not use strong acidity flux, more than 0.2wt%

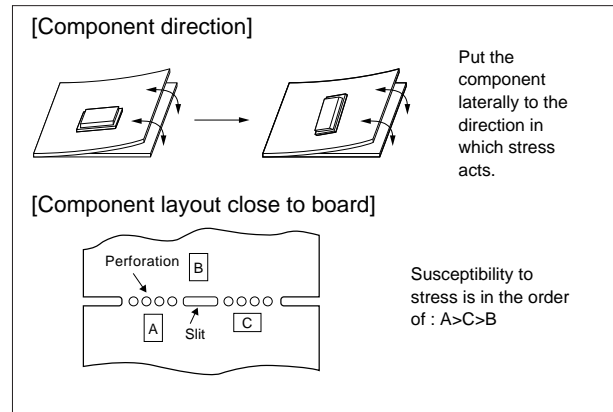

chlorine content, in flow soldering.

6. In case of covering discriminator with over coat, conditions such as material of resin, cure temperature, and so on should be evaluated carefully.
7. Accurate test circuit values are required to measure electrical characteristics. It may be a cause of miscorrelation if there is any deviation, especially stray capacitance, from the test circuit in the specification.

Notice (Handling)

■ Ceramic Discriminator 3.5-6.5MHz

1. Do not use this product with bend. The component may be damaged if excess mechanical stress is applied to it mounted on the printed circuit board.
2. The component may be damaged when an excess stress is applied.
3. All kinds of re-flow soldering must not be applied on the component.
4. Do not clean or wash the component as it is not hermetically sealed.
5. Please contact Murata or Murata representative for soldering condition, in case of using lead free solder.
6. Do not use strong acidity flux, more than 0.2wt% chlorine content, in flow soldering.
7. In case of covering filter with over coat, conditions such as material of resin, cure temperature, and so on should be evaluated carefully.
8. Accurate test circuit values are required to measure electrical characteristics. It may be a cause of miscorrelation if there is any deviation, especially stray capacitance, from the test circuit in the specification.

Packaging

■ Minimum Quantity

	Taping		Ammo Pack	Bulk	Magazine	Box
	ø330mm	ø180mm				
CERAFIL®<10.7MHz>						
	SFECS		2,000			
	SFECD		2,000			
	SFEKV		2,000			
	SFELA			1,500	500	
	SFELB			1,500	500	
	SFVLA			1,000	500	
	SFKLA			1,500	500	
	SFTLA				500	
CERAFIL®<3.5-6.5MHz>						
	SFSKA	3,000				
	SFSRA		2,000	500		
	SFSRL			500		
	SFTRD			500		
	SFSRH		1,500	500		
CERAFIL®<455kHz>						
	PFWCC					1,000
	SFPCA	1,000				
	SFULA			500	50	
	SFZLA			200	50	
	PFSLA		1,500	500		
	PFWLA		1,500	500		
	SFPLA				50	200
	CFWLA				50	150
	CFULA					200
	BFULA			500		
Ceramic Traps<3.5-6.5MHz>						
	TPSKA	3,000				
	TPWKA	3,000				
	TPSRA		2,000	500		
	TPSRD		1,500	500		
	TPWRD		1,500	500		
	TPTRD		1,500	500		
Ceramic Discriminators<10.7MHz>						
	CDSCB					2,000
	CDALA		1,500	500		
Ceramic Discriminators<3.5-6.5MHz>						
	CDSRH		1,500	500		
	CDSRL			500		

Continued on the following page. 

Packaging

Continued from the preceding page.

■ CERAFIL® 10.7MHz Chip Type

SFECS Series

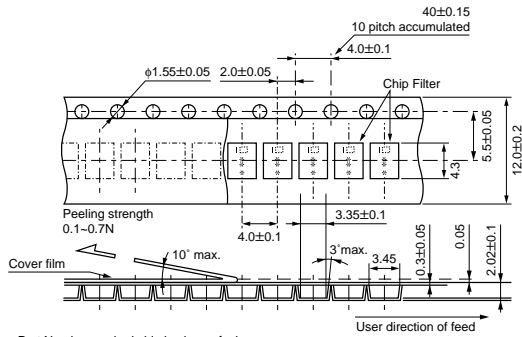

- Part Number marked side is always facing up.
 - The feeding holes side of cavity tape is always input terminal.
- (in mm)

SFECD Series

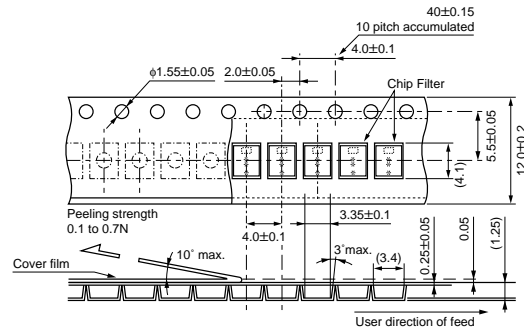

- Part Number marked side is always facing up.
 - The feeding holes side of cavity tape is always input terminal.
- () : Reference (in mm)

SFEVCV Series

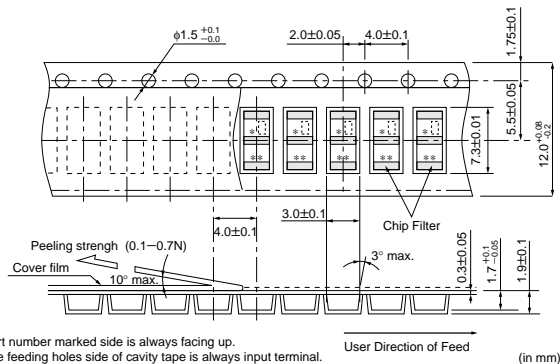

- Part number marked side is always facing up.
 - The feeding holes side of cavity tape is always input terminal.
- (in mm)

Continued on the following page. ↗

Packaging

Continued from the preceding page.

■ CERAFIL® 10.7MHz Lead Type SF_LA Series

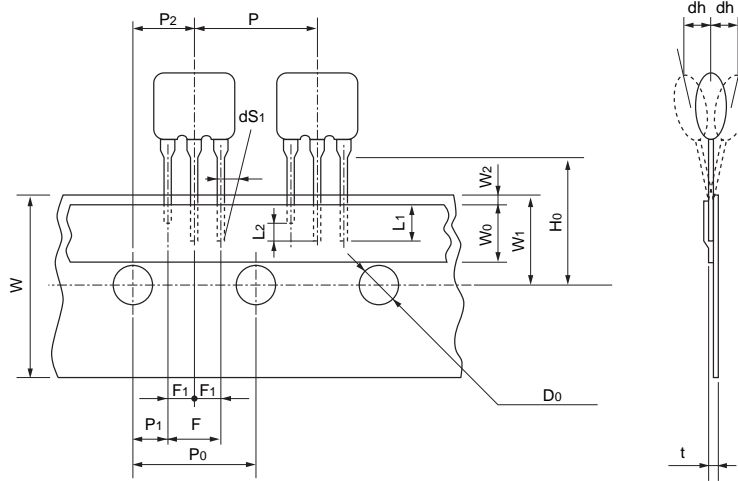

Item	Code	Dimensions	Tolerance	Remarks
Lead length under the hold down tape	L1	3.0 min.		
Length of cut off	L2	2.0 max.		To distinguish the direction
Pitch of components	P	12.7	±0.5	
Pitch of sprocket hole (I)	P0	12.7	±0.2	
Length from hole center to lead	P1	3.85	±0.5	
Length from hole center to component center	P2	6.35	±0.5	
Lead spacing (I)	F	5.0	+0.5 -0.2	
Lead spacing (II)	F1	2.5	±0.2	
Slant to the forward or backward	dh	0	±1.0	
Slant to the left or right	dS1	0	±1.0	
Width of carrier tape	W	18.0	±0.5	
Width of hold down tape	W0	6.0 min.		
Position of sprocket hole	W1	9.0	±0.5	
Gap of hold down tape and carrier tape	W2	0	+0.5 -0	Hold down tape doesn't exceed the carrier tape
Distance between the center of sprocket hole and lead stopper	H0	18.0	±0.5	
Diameter of sprocket hole	D0	ø4.0	±0.2	
Total tape thickness	t	0.6	±0.2	
Pitch of sprocket hole (II)	P020	254.0	±1.5	The pitch of 20 sprocket holes

(in mm)

Continued on the following page. ↗

Packaging

Continued from the preceding page.

■ CERAFIL® 4.5-6.5MHz Chip Type SFSKA Series

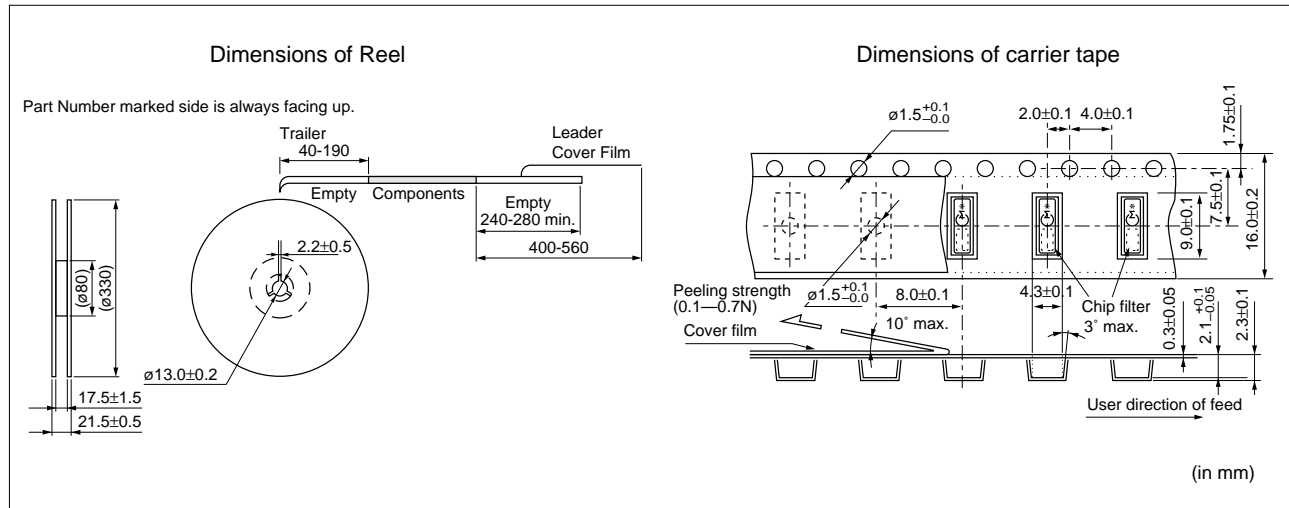

Continued on the following page. ↗

Packaging

Continued from the preceding page.

■ CERAFIL® 4.5-6.5MHz Lead Type SFSRA Series

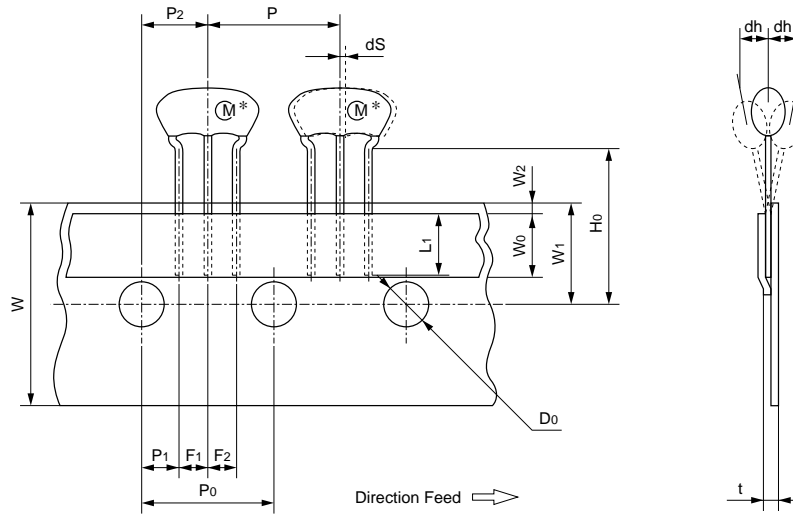

Item	Code	Dimensions	Tolerance	Remarks
Lead length under the hold down tape	L1	5.0 min.		
Pitch of component	P	12.7	±0.5	Tolerance for Pitches 10XP0=127±1
Pitch of sprocket hole (I)	P0	12.7	±0.2	
Length from hole center to lead	P1	3.85	±0.5	
Length from hole center to component center	P2	6.35	±0.5	
Lead spacing (I)	F1	2.5	±0.2	
Lead spacing (II)	F2	2.5	±0.2	
Slant to the forward or backward	dh	0	±1.0	
Width of carrier tape	W	18.0	±0.5	
Width of hold down tape	W0	6.0 min.		
Position of Sprocket hole	W1	9.0	±0.5	
Gap of hold down tape and carrier Tape	W2	0	+0.5 -0	Hold down tape doesn't exceed the carrier tape.
Distance between the center of sprocket hole and lead stopper	H0	18.0	±0.5	
Diameter of sprocket hole	D0	ø4.0	±0.2	
Total tape thickness	t	0.6	±0.2	
Pitch of sprocket hole (II)	P020	254.0	±1.5	The pitch of 20 sprocket holes
Body tilt	dS	0	±1.0	

(in mm)

Continued on the following page. ↗

Packaging

Continued from the preceding page.

CERAFIL® 455kHz Chip Type PFWCC Series

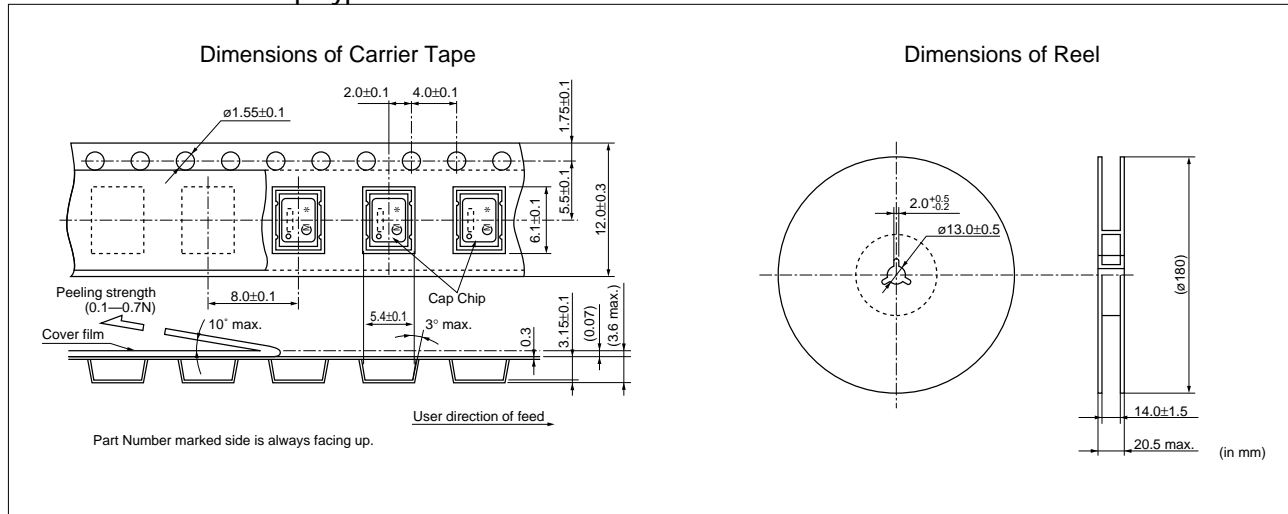

CERAFIL® 455kHz Chip Type SFPCA Series

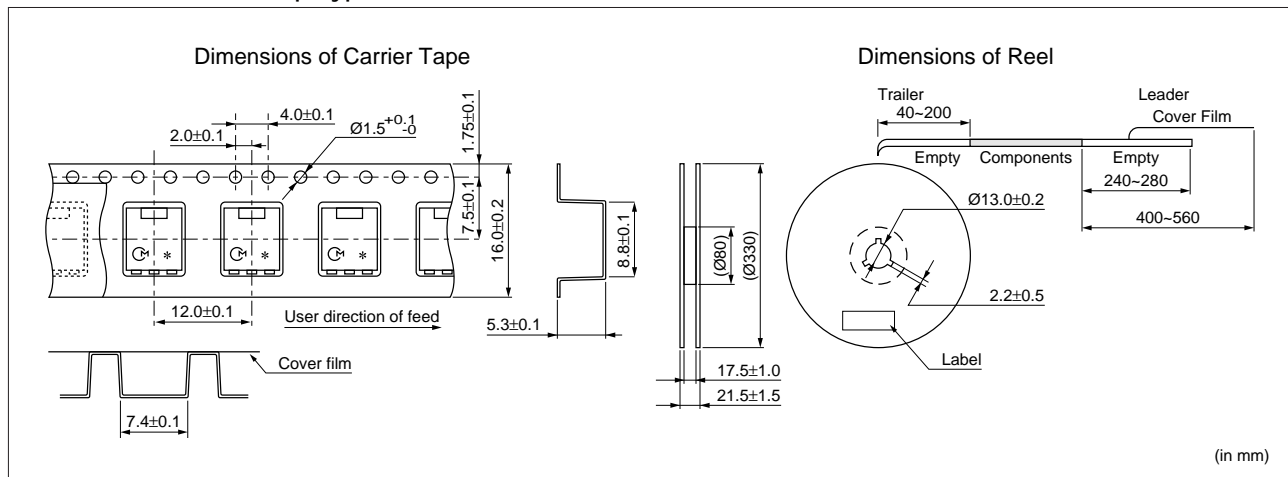

Continued on the following page.

Packaging

Continued from the preceding page.

■ CERAFIL® 455kHz Lead Type PFSLA/PFWLA Series

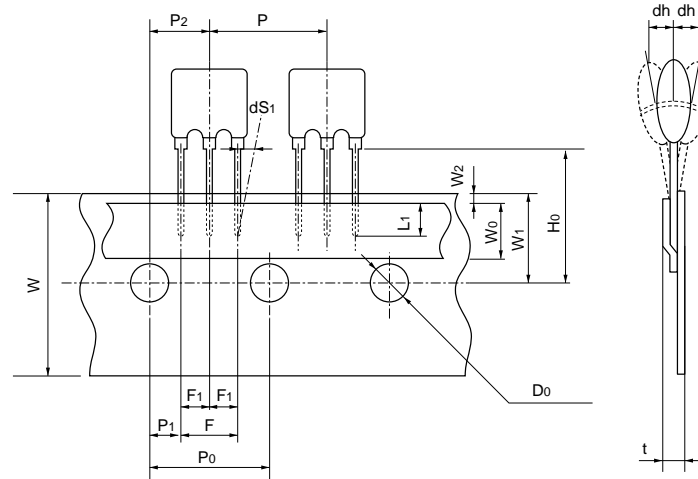

Item	Code	Dimensions	Tolerance	Note
Lead length under the hold down tape	L1	3.0 min.		
Pitch of component	P	12.7	±0.5	
Pitch of sprocket hole (1)	P0	12.7	±0.2	
Length from hole center to lead	P1	3.85	±0.5	
Length from hole center to component center	P2	6.35	±0.5	
Lead spacing (1)	F	5.0	+0.5 -0.2	
Lead spacing (2)	F1	2.5	±0.2	
Slant to the forward or backward	dh	0	±1.0	
Slant to the left or right	dS1	0	±1.0	
Width of carrier tape	W	18.0	±0.5	
Width of hold down tape	W0	6.0 min.		
Position of sprocket hole	W1	9.0	±0.5	
Gap of hold down tape and carrier tape	W2	0	+0.5 -0	Hold-down tape doesn't exceed the carrier tape.
Distance between the center of sprocket hole and lead stopper	H0	18.0	±0.5	
Diameter of sprocket hole	Do	ø4.0	±0.2	
Total tape thickness	t	0.6	±0.2	
Pitch of sprocket hole (2)	P020	254.0	±1.5	The pitch of 20 sprocket holes

(in mm)

Continued on the following page.

Packaging

☐ Continued from the preceding page.

■ CERAFIL® 455kHz Lead Type SFULA Series Standard of Magazine Cassette

1. Putting CERAFIL® into Magazine

A magazine should contain 50pcs of CERAFIL®, with the marking of products all facing toward the "muRata" mark on a magazine, and be closed with exclusive stoppers at both ends. Above should be the minimum packaging unit.

2. Quality of Magazine

- (1) Transparent so that input / output direction is visually recognizable.
- (2) With an angle of 35° CERAFIL® should slip down smoothly.
- (3) Antistatic finish
- (4) Recycling

Note : Magazines should be sent back for recycling.
(Therefore, empty magazines should not be damaged.)

3. Dimensions of Magazine Cassette

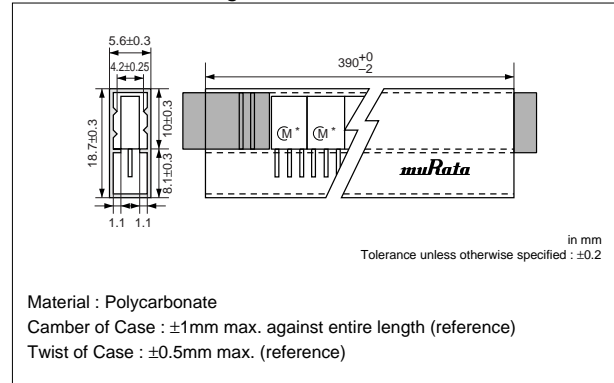

■ CERAFIL® 455kHz Lead Type SFZLA Series Standard of Magazine Cassette

1. Putting CERAFIL® into Magazine

A magazine should contain 50pcs of CERAFIL®, with the marking of products all facing toward the "muRata" mark on a magazine, and be closed with exclusive stoppers at both ends. Above should be the minimum packaging unit.

2. Quality of Magazine

- (1) Transparent so that input / output direction is visually recognizable.
- (2) With an angle of 35° CERAFIL® should slip down smoothly.
- (3) Antistatic finish
- (4) Recycling

Note : Magazines should be sent back for recycling.
(Therefore, empty magazines should not be damaged.)

3. Dimensions of Magazine Cassette

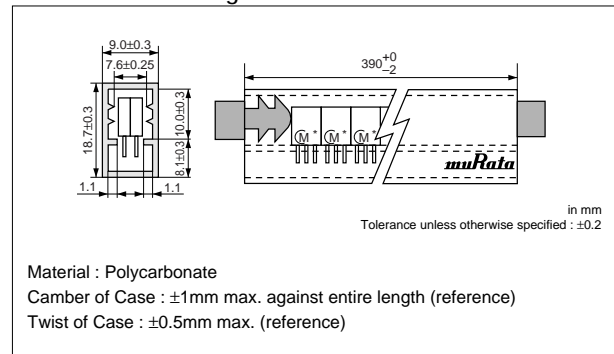

■ CERAFIL® 455kHz Lead Type SFPLA Series Standard of Magazine Cassette

1. Putting CERAFIL® into Magazine

A magazine should contain 50pcs of CERAFIL®, which ground terminals are all facing toward the "muRata" mark on a magazine, and be closed with exclusive stoppers at the both ends. Above should be the minimum packaging unit.

2. Quality of Magazine

- (1) Transparent so that input / output direction is visually recognizable.
- (2) With an angle of 35° CERAFIL® should slip down smoothly.
- (3) Antistatic finish
- (4) Recycling

Note : Magazines should be sent back for recycling.
(Therefore, empty magazines should not be damaged.)

3. Dimensions of Magazine Cassette

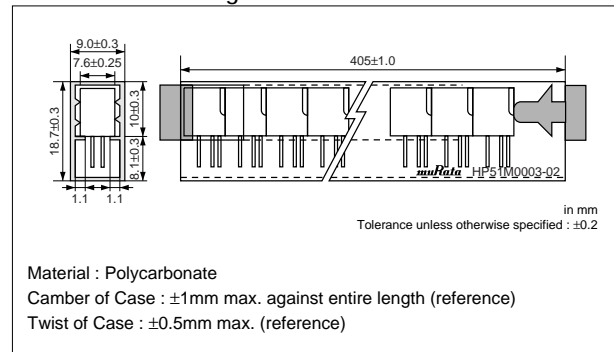

Continued on the following page. ☐

Packaging

Continued from the preceding page.

■ CERAFIL® 455kHz Lead Type CFWLA Series Standard of Magazine Cassette

1. Putting CERAFIL® into Magazine

A magazine should contain 50pcs of CERAFIL®, with ground terminals all facing toward the "muRata" mark on a magazine, and be closed with exclusive stoppers at the both ends. Above should be the minimum packaging unit.

2. Quality of Magazine

- (1) Transparent so that input / output direction is visually recognizable.
- (2) With an angle of 35° CERAFIL® should slip down smoothly.
- (3) Antistatic finish
- (4) Recycling
Note : Magazines should be sent back for recycling.
(Therefore, empty magazines should not be damaged.)

3. Magazine should be packaged in a cardboard box.

MURATA model name, quantity and outgoing inspection number should be indicated on the box.

Cardboard box may contain maximum 33 magazines (1,650 pieces of filter).

4. Dimensions of Magazine Cassette

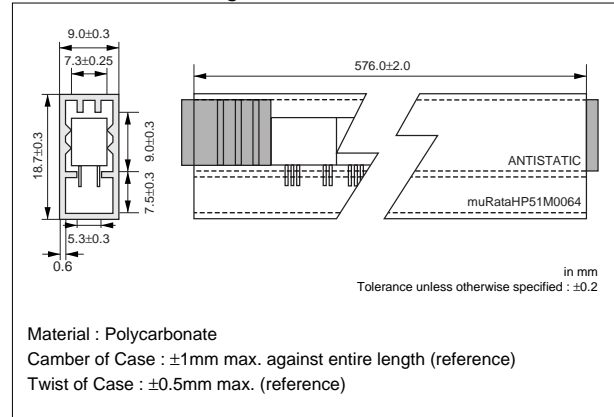

■ Ceramic Trap 4.5-6.5MHz Chip Type TPSKA Series

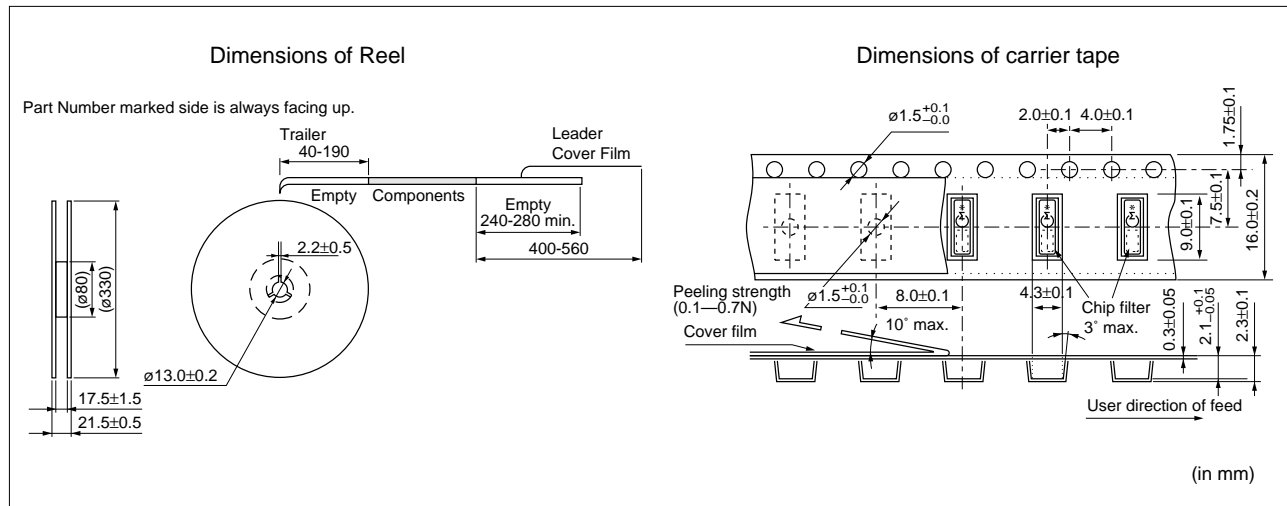

Continued on the following page. ↗

Packaging

☒ Continued from the preceding page.

■ Ceramic Trap 4.5-6.5MHz Chip Type TPWKA Series

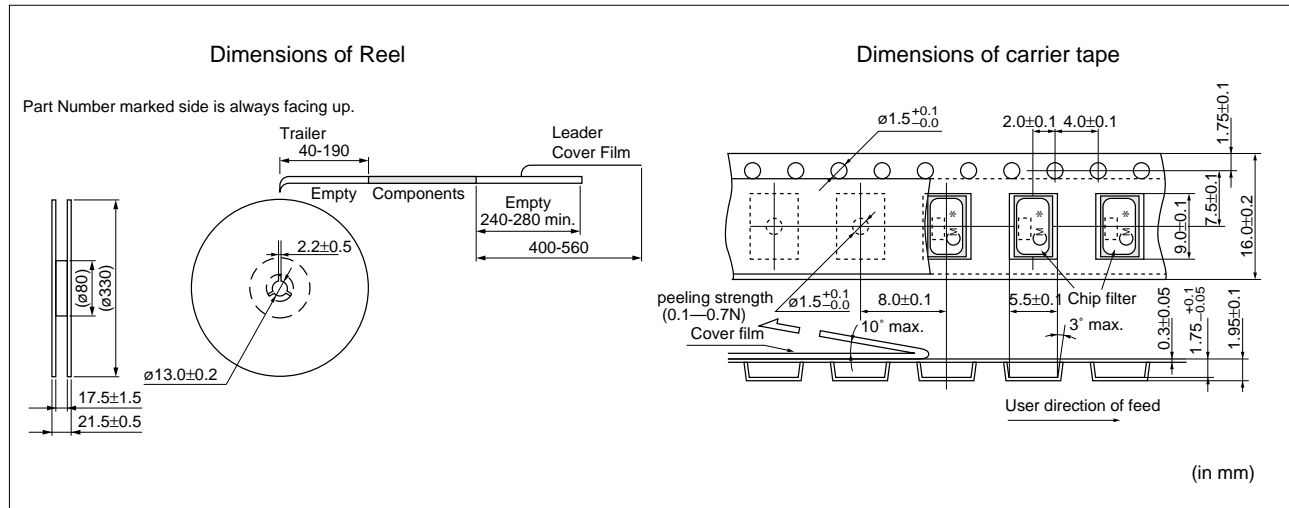

Continued on the following page. ☒

Packaging

Continued from the preceding page.

■ Ceramic Trap 4.5-6.5MHz Lead Type TPSRA Series

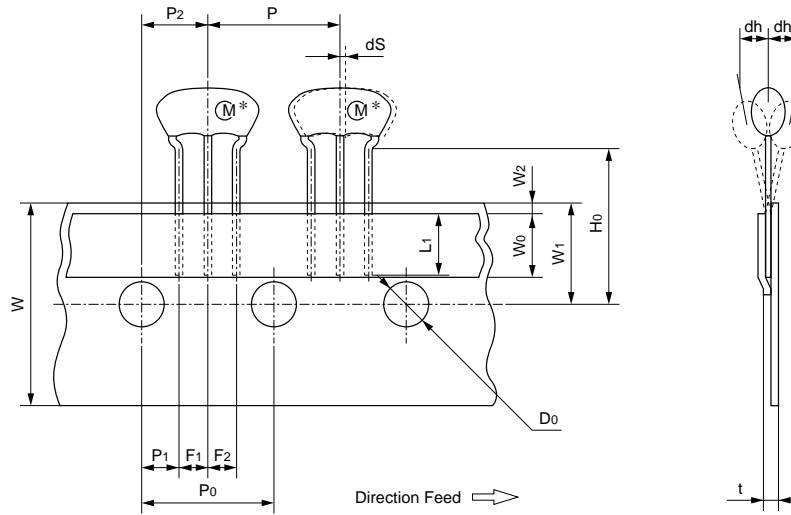

Item	Code	Dimensions	Tolerance	Remarks
Lead length under the hold down tape	L1	5.0 min.		
Pitch of component	P	12.7	±0.5	Tolerance for Pitches 10X P0=127±1
Pitch of sprocket hole (I)	P0	12.7	±0.2	
Length from hole center to lead	P1	3.85	±0.5	
Length from hole center to component center	P2	6.35	±0.5	
Lead spacing (I)	F1	2.5	±0.2	
Lead spacing (II)	F2	2.5	±0.2	
Slant to the forward or backward	dh	0	±1.0	
Width of carrier tape	W	18.0	±0.5	
Width of hold down tape	W0	6.0 min.		
Position of Sprocket hole	W1	9.0	±0.5	
Gap of hold down tape and carrier Tape	W2	0	+0.5 -0	Hold down tape doesn't exceed the carrier tape.
Distance between the center of sprocket hole and lead stopper	H0	18.0	±0.5	
Diameter of sprocket hole	D0	ø4.0	±0.2	
Total tape thickness	t	0.6	±0.2	
Pitch of sprocket hole (II)	P020	254.0	±1.5	The pitch of 20 sprocket holes
Body tilt	dS	0	±1.0	

(in mm)

Continued on the following page.

Packaging

Continued from the preceding page.

■ Ceramic Trap 3.5-6.5MHz Lead Type TPSRD Series

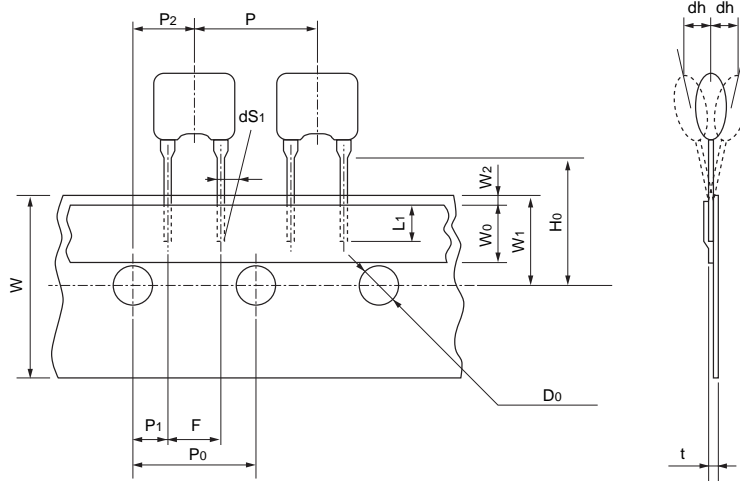

Item	Code	Dimensions	Tolerance	Remarks
Lead length under the hold down tape	L1	3.0 min.	—	
Pitch of component	P	12.7	±0.5	
Pitch of sprocket hole (I)	P0	12.7	±0.2	
Length from hole center to lead	P1	3.85	±0.5	
Length from hole center to component center	P2	6.35	±0.5	
Lead spacing	F	5.0	+0.5 -0.2	
Slant to the forward or backward	dh	0	±1.0	
Slant to the left or right	dS1	0	±1.0	
Width of carrier tape	W	18.0	±0.5	
Width of hold down tape	W0	6.0 min.	—	
Position of sprocket hole	W1	9.0	±0.5	
Gap of hold down tape and carrier tape	W2	0	+0.5 -0.0	Hold down tape doesn't exceed the carrier tape
Distance between the center of sprocket hole and lead stopper	H0	18.0	±0.5	
Diameter of sprocket hole	D0	ø4.0	±0.2	
Total tape thickness	t	0.6	±0.2	
Pitch of sprocket hole (II)	Po20	254.0	±1.5	The pitch of 20 sprocket holes

(in mm)

Continued on the following page. ↗

Packaging

☐ Continued from the preceding page.

■ Ceramic Trap 3.5-6.5MHz Lead Type TPSRD_W/TPWRD/TPTRD Series

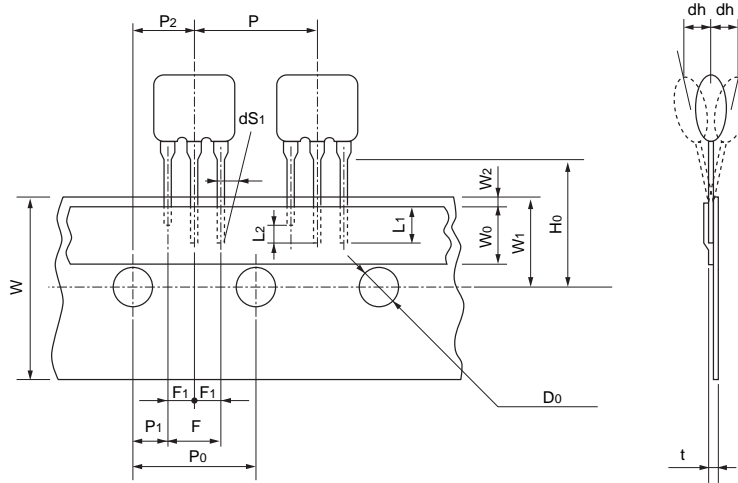

Item	Code	Dimensions	Tolerance	Remarks
Lead length under the hold down tape	L1	3.0 min.		
Length of cut off	L2	2.0 max.		To distinguish the direction
Pitch of components	P	12.7	±0.5	
Pitch of sprocket hole (I)	P0	12.7	±0.2	
Length from hole center to lead	P1	3.85	±0.5	
Length from hole center to component center	P2	6.35	±0.5	
Lead spacing (I)	F	5.0	+0.5 -0.2	
Lead spacing (II)	F1	2.5	±0.2	
Slant to the forward or backward	dh	0	±1.0	
Slant to the left or right	dS1	0	±1.0	
Width of carrier tape	W	18.0	±0.5	
Width of hold down tape	W0	6.0 min.		
Position of sprocket hole	W1	9.0	±0.5	
Gap of hold down tape and carrier tape	W2	0	+0.5 -0	Hold down tape doesn't exceed the carrier tape
Distance between the center of sprocket hole and lead stopper	H0	18.0	±0.5	
Diameter of sprocket hole	D0	ø4.0	±0.2	
Total tape thickness	t	0.6	±0.2	
Pitch of sprocket hole (II)	P020	254.0	±1.5	The pitch of 20 sprocket holes

(in mm)

Continued on the following page. ☐

Packaging

Continued from the preceding page.

■ Ceramic Discriminator 10.7MHz Chip Type CDSCB Series

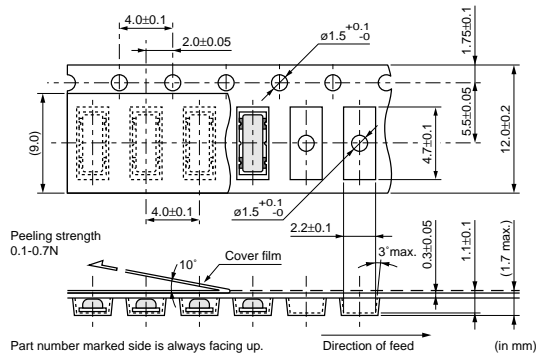

Continued on the following page. ↗

Packaging

Continued from the preceding page.

■ Ceramic Discriminator 10.7MHz Lead Type CDALA Series

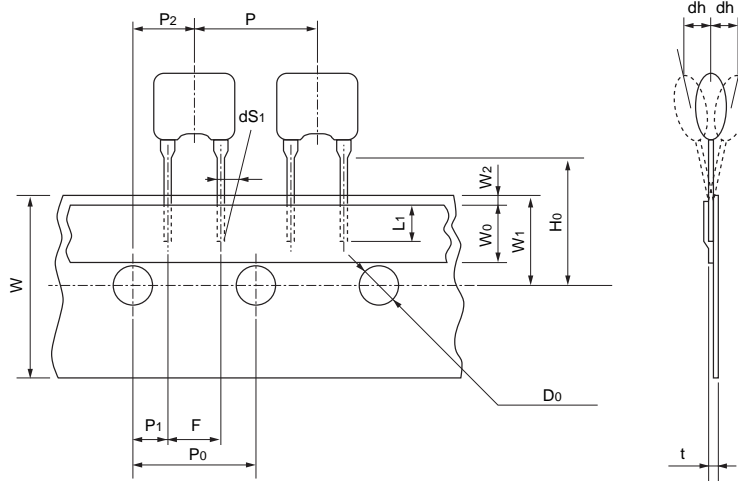

Item	Code	Dimensions	Tolerance	Remarks
Lead length under the hold down tape	L1	3.0 min.	—	
Pitch of component	P	12.7	±0.5	
Pitch of sprocket hole (I)	P0	12.7	±0.2	
Length from hole center to lead	P1	3.85	±0.5	
Length from hole center to component center	P2	6.35	±0.5	
Lead spacing	F	5.0	+0.5 -0.2	
Slant to the forward or backward	dh	0	±1.0	
Slant to the left or right	dS1	0	±1.0	
Width of carrier tape	W	18.0	±0.5	
Width of hold down tape	W0	6.0 min.	—	
Position of sprocket hole	W1	9.0	±0.5	
Gap of hold down tape and carrier tape	W2	0	+0.5 -0.0	Hold down tape doesn't exceed the carrier tape
Distance between the center of sprocket hole and lead stopper	H0	18.0	±0.5	
Diameter of sprocket hole	D0	ø4.0	±0.2	
Total tape thickness	t	0.6	±0.2	
Pitch of sprocket hole (II)	Po20	254.0	±1.5	The pitch of 20 sprocket holes

(in mm)

Continued on the following page. ↗

Packaging

Continued from the preceding page.

■ Ceramic Discriminator 3.5-6.5MHz CDSRH_EK Series

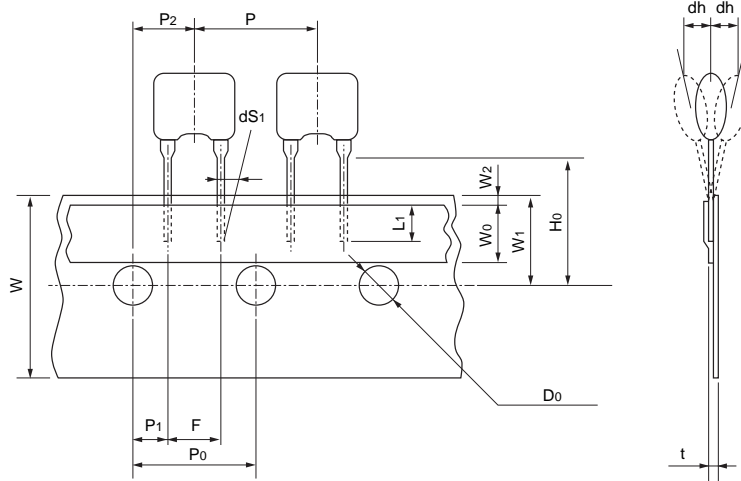

Item	Code	Dimensions	Tolerance	Remarks
Lead length under the hold down tape	L1	3.0 min.	—	
Pitch of component	P	12.7	±0.5	
Pitch of sprocket hole (I)	P0	12.7	±0.2	
Length from hole center to lead	P1	3.85	±0.5	
Length from hole center to component center	P2	6.35	±0.5	
Lead spacing	F	5.0	+0.5 -0.2	
Slant to the forward or backward	dh	0	±1.0	
Slant to the left or right	dS1	0	±1.0	
Width of carrier tape	W	18.0	±0.5	
Width of hold down tape	W0	6.0 min.	—	
Position of sprocket hole	W1	9.0	±0.5	
Gap of hold down tape and carrier tape	W2	0	+0.5 -0.0	Hold down tape doesn't exceed the carrier tape
Distance between the center of sprocket hole and lead stopper	H0	18.0	±0.5	
Diameter of sprocket hole	D0	ø4.0	±0.2	
Total tape thickness	t	0.6	±0.2	
Pitch of sprocket hole (II)	Po20	254.0	±1.5	The pitch of 20 sprocket holes

(in mm)

Continued on the following page. ↗

Packaging

Continued from the preceding page.

■ Ceramic Discriminator 3.5-6.5MHz CDSRH_CK Series

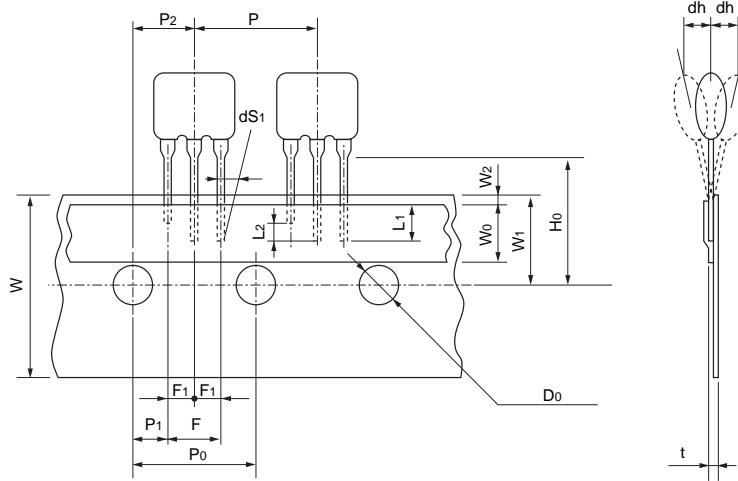

Item	Code	Dimensions	Tolerance	Remarks
Lead length under the hold down tape	L1	3.0 min.		
Length of cut off	L2	2.0 max.		To distinguish the direction
Pitch of components	P	12.7	±0.5	
Pitch of sprocket hole (I)	P0	12.7	±0.2	
Length from hole center to lead	P1	3.85	±0.5	
Length from hole center to component center	P2	6.35	±0.5	
Lead spacing (I)	F	5.0	+0.5 -0.2	
Lead spacing (II)	F1	2.5	±0.2	
Slant to the forward or backward	dh	0	±1.0	
Slant to the left or right	dS1	0	±1.0	
Width of carrier tape	W	18.0	±0.5	
Width of hold down tape	W0	6.0 min.		
Position of sprocket hole	W1	9.0	±0.5	
Gap of hold down tape and carrier tape	W2	0	+0.5 -0	Hold down tape doesn't exceed the carrier tape
Distance between the center of sprocket hole and lead stopper	H0	18.0	±0.5	
Diameter of sprocket hole	D0	ø4.0	±0.2	
Total tape thickness	t	0.6	±0.2	
Pitch of sprocket hole (II)	P020	254.0	±1.5	The pitch of 20 sprocket holes

(in mm)

⚠Note:

1. Export Control

(For customers outside Japan)

Murata products should not be used or sold for use in the development, production, stockpiling or utilization of any conventional weapons or mass-destructive weapons (nuclear weapons, chemical or biological weapons, or missiles), or any other weapons.

(For customers in Japan)

For products which are controlled items subject to the "Foreign Exchange and Foreign Trade Law" of Japan, the export license specified by the law is required for export.

2. Please contact our sales representatives or product engineers before using the products in this catalog for the applications listed below, which require especially high reliability for the prevention of defects which might directly damage to a third party's life, body or property, or when one of our products is intended for use in applications other than those specified in this catalog.

- | | |
|-----------------------------|---|
| ① Aircraft equipment | ② Aerospace equipment |
| ③ Undersea equipment | ④ Power plant equipment |
| ⑤ Medical equipment | ⑥ Transportation equipment (vehicles, trains, ships, etc.) |
| ⑦ Traffic signal equipment | ⑧ Disaster prevention / crime prevention equipment |
| ⑨ Data-processing equipment | ⑩ Application of similar complexity and/or reliability requirements to the applications listed in the above |

3. Product specifications in this catalog are as of January 2003. They are subject to change or our products in it may be discontinued without advance notice. Please check with our sales representatives or product engineers before ordering. If there are any questions, please contact our sales representatives or product engineers.

4. Please read rating and ⚠CAUTION (for storage, operating, rating, soldering, mounting and handling) in this catalog to prevent smoking and/or burning, etc.

5. This catalog has only typical specifications because there is no space for detailed specifications. Therefore, please approve our product specifications or transact the approval sheet for product specifications before ordering.

6. Please note that unless otherwise specified, we shall assume no responsibility whatsoever for any conflict or dispute that may occur in connection with the effect of our and/or a third party's intellectual property rights and other related rights in consideration of your use of our products and/or information described or contained in our catalogs. In this connection, no representation shall be made to the effect that any third parties are authorized to use the rights mentioned above under licenses without our consent.

7. No ozone depleting substances (ODS) under the Montreal Protocol are used in our manufacturing process.



<http://www.murata.com/>

Head Office
2-26-10, Tenjin Nagaokakyo-shi, Kyoto 617-8555, Japan Phone: 81-75-951-9111

International Division
3-29-12, Shibuya, Shibuya-ku, Tokyo 150-0002, Japan
Phone: 81-3-5469-6123 Fax: 81-3-5469-6155 E-mail: intl@murata.co.jp