

FEATURES

- 20 - 2000 MHz
- 60 dB Isolation
- 13 mA, +5 VDC
- TTL Driver
- Non-Reflective
- Replaceable SMA Connectors



**MODEL NO.
CDS0623**

PIN Diode SP3T

SP3T

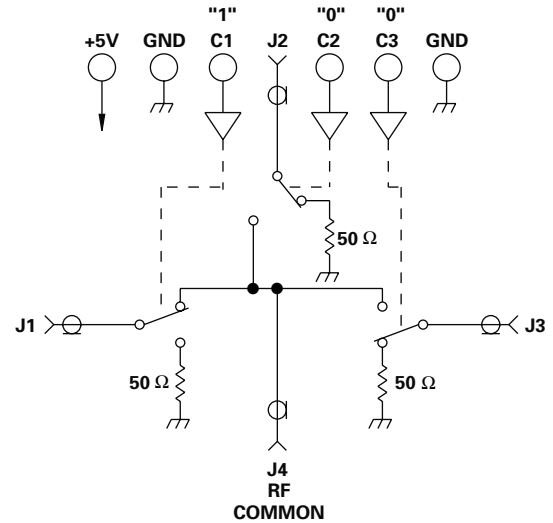
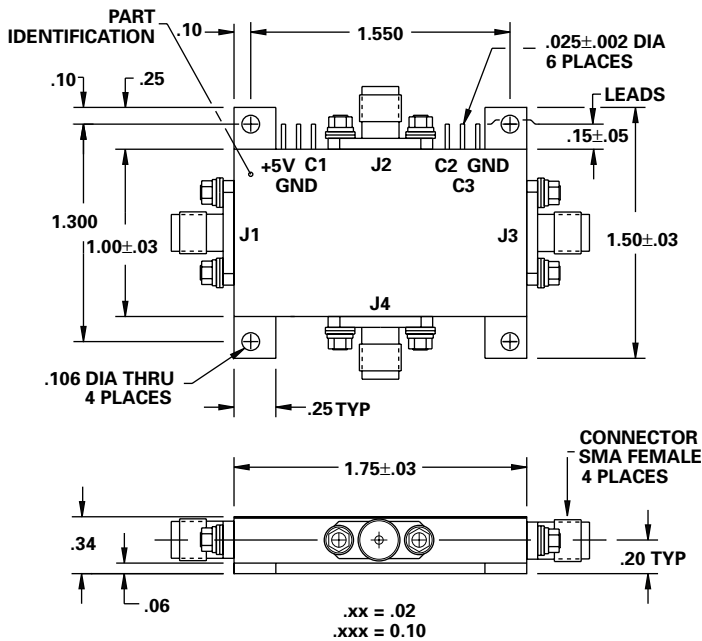

GUARANTEED PERFORMANCE

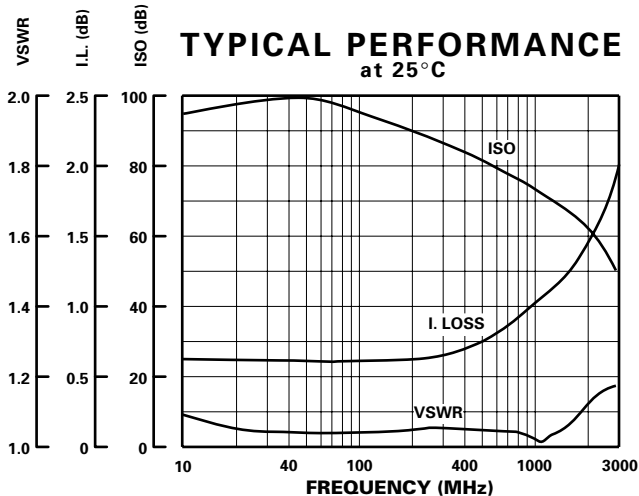

Parameter	Min	Typ	Max	Units	Conditions
Operating Frequency	20		2000	MHz	
DC Current		13	20	mA	At +5 VDC Supply
Control Type		TTL			3 Lines Logic "0" = Off Logic "1" = On
Control Current	High Low	0 0	±10 ±10	µA	V _{IH} = +2.7V V _{IL} = +0.5V
Insertion Loss		1.0	1.5	dB	20 - 1000 MHz 1000 - 2000 MHz
Isolation	60	74		dB	20 - 1000 MHz 1000 - 2000 MHz
VSWR	Thru Termination	1.15/1 1.06/1	1.3/1 1.3/1		
Impedance		50		OHMS	
Switching Speed		1.6	3	µSEC	50% Cont to 90% / 10% RF
Transition (Rise/Fall) Time		0.5		µSEC	90% / 10% or 10% / 90% RF
Switching (Video) Transients		0.5		V	Peak Value
Intercept Points	2nd 3rd	+79 +40		dBm	50 MHz / 70 MHz 50 MHz / 35 MHz
RF Power	Operate No Damage	+15 +23	+9 +15 +27	dBm	20 - 100 MHz 100 - 2000 MHz
Operating Temperature	-55	+25	+125	°C	TA