

SMD Schottky Barrier Rectifier

SS32-G THRU SS310-G

Forward Current: 3.0 Amp

Reverse Voltage: 20 ~ 100 Volts

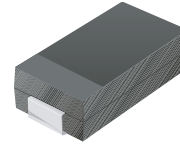

Features

- Ideal for surface mount applications
- Easy pick and place
- Plastic packages has Underwriters lab. Flammability classification 94V-0
- Built-in strain relief
- Low forward voltage drop

Mechanical Data

- Case: JEDEC DO-214AB molded plastic
- Epoxy: UL 94-0 rate flame retardant
- Terminal: Solderable per MIL-STD-750 method 2026
- Polarity: Color band denotes cathode end
- Mounting position: Any
- Approx. Weight: 0.21 gram

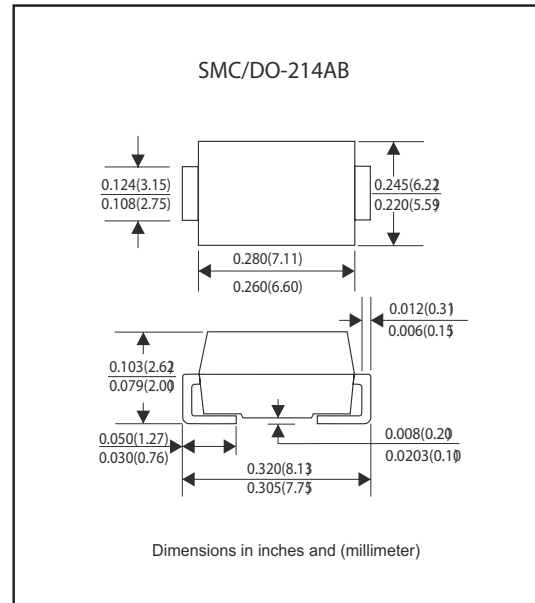

Maximum Rating and Electrical Characteristics

Parameter	Symbol	SS32-G	SS34-G	SS36-G	SS310-G	Unit
Max. Repetitive Peak Reverse Voltage	V_{RRM}	20	40	60	100	V
Max. DC Blocking Voltage	V_{DC}	20	40	60	100	V
Max. RMS Voltage	V_{RMS}	14	28	42	70	V
Peak Surge Forward Current 8.3ms single half sine-wave superimposed on rated load (JEDEC method)	I_{FSM}	80				A
Max. Average Forward Current	I_o	3.0				A
Max. Instantaneous Forward Current at 2.0 A	V_F	0.50		0.75	0.85	V
Max. DC Reverse Current at Rated DC Blocking Voltage $T_a=25^{\circ}C$	I_R	0.5				mA
$T_a=100^{\circ}C$		20		10		
Max. Thermal Resistance (Note 1)	$R_{\theta JA}$ $R_{\theta JL}$	50 10				$^{\circ}C/W$
Operating Junction temperature	T_j	-50 to +125				$^{\circ}C$
Storage Temperature	T_{STG}	-65 to +150				$^{\circ}C$

“-G” suffix designates RoHS compliant Version



Rating and Characteristic Curves (SS32-G Thru SS310-G)

Fig. 1 - Reverse Characteristics

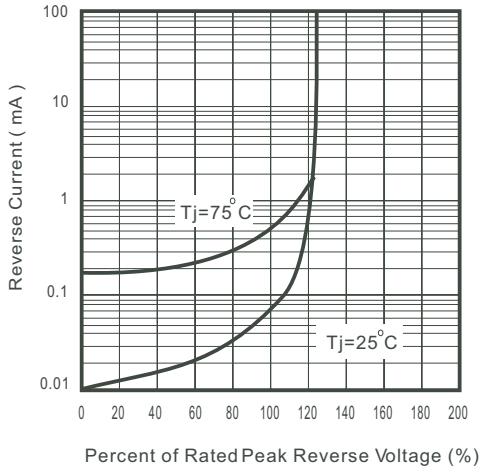

Fig.2 - Forward Characteristics

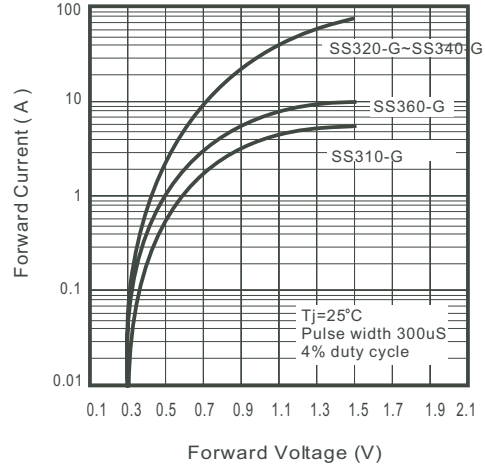

Fig. 3 - Junction Capacitance

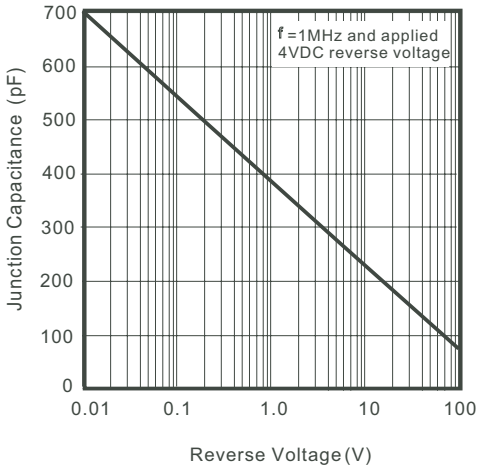

Fig. 4 - Current Derating Curve

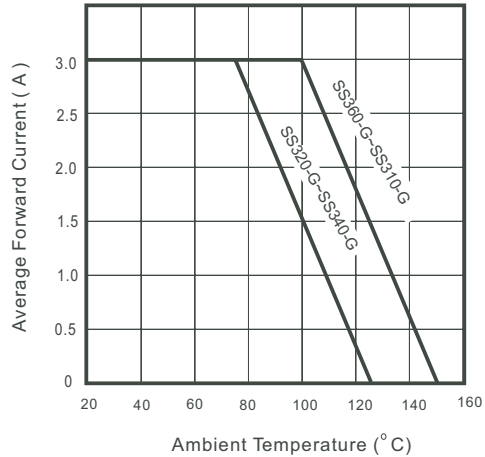

Fig. 5 - Non Repetitive Forward Surge Current

