

NEW

0.4mm Contact Pitch, 1.5mm above the board, Board-to-Board / Board-to-FPC Connectors

DF18 Series

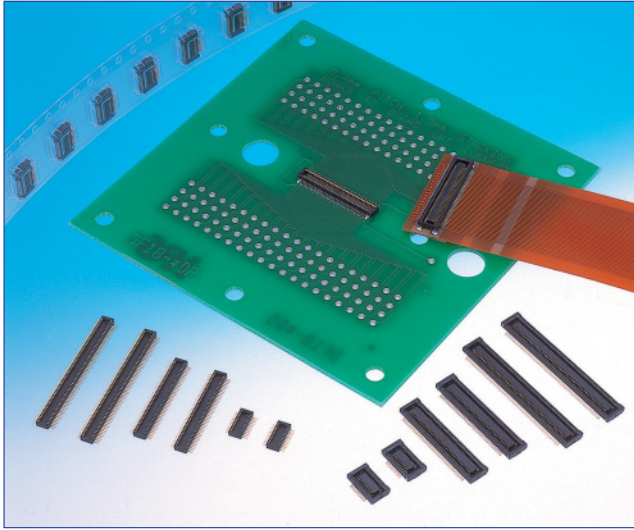

Low profile – Board-to-board distance of 1.5 mm

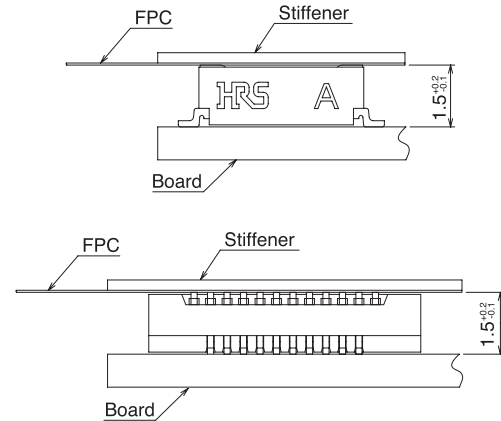

■ Features

1. Allows higher mounting density of board components

Extremely small board mounting pattern and low above-the-board profile makes the connector suitable for small device applications.

2. High Contact Reliability

Despite its small size and low profile the contacts have large deflection distance, guaranteeing reliable electrical performance.

3. Good Mating Characteristics

Large lead-in distance of 0.33 mm in horizontal directions and tactile “click” confirms fully mated condition of connectors.

4. Optional Additional Board Retention

For applications requiring extra-strong hold of connectors to the board connectors can be ordered with optional metal hold-down.

5. Automatic Board Placement

Connectors have large flat width (Plug: 1.4 mm, Receptacle: 1.44mm) to accommodate pick-up with automatic placement machines.

High Contact Reliability – Effective connection wipe of 0.4 mm

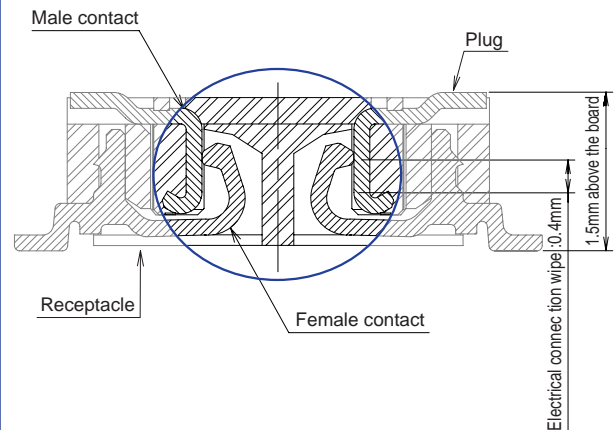

Self-alignment distance: 0.33 mm

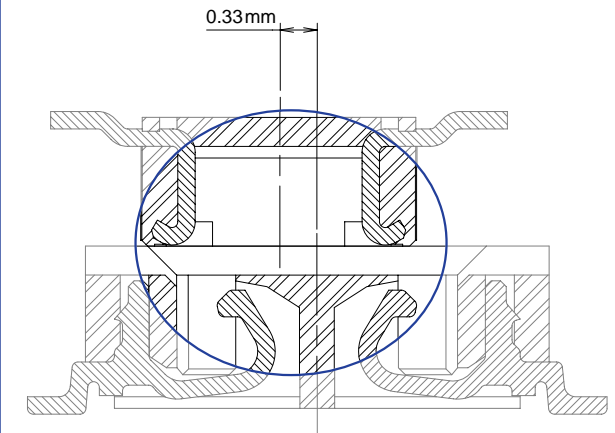

■ Applications

Digital video cameras, Digital still cameras, cellular phones, miniature displays, cameras portable equipment and other applications requiring small reliable board-to-board and FPC-to-Board connections.

Product Specifications

Rating	Current rating	0.3A	Operating temperature range	-35°C to +85°C (Note 1)	Storage temperature range	-10°C to +60°C (Note 2)
	Voltage rating	30V AC	Operating humidity range	40°C to 80°C (Note 2)	Storage humidity range	40°C to 70°C (Note 2)

Item	Specification	Conditions
1. Insulation resistance	50 M ohms min.	100 V DC
2. Withstanding voltage	No flashover or insulation breakdown.	100 V AC / one minute
3. Contact resistance	60 m ohms max.	1 mA AC, 20mv max., 1KHz
4. Vibration	No electrical discontinuity of 1 ms or more.	Frequency: 10 to 55 Hz, single amplitude of 0.75 mm, 2 hours / 3 axis.
5. Humidity	Contact resistance: 60 m ohms max. Insulation resistance: 25 M ohms min.	96 hours at temperature of 40±2°C and humidity of 90 to 95%
6. Temperature cycle	Contact resistance: 60 m ohms max. Insulation resistance: 50 M ohms min.	Temperature: -55°C--> +15°C to +35°C--> +85°C--> +15°C to +35°C Duration: 30 --> 2 to 3 --> 30 --> 2 to 3 (Minutes) 5 cycles
7. Durability (insertion/ withdrawal)	Contact resistance: 60 m ohms max.	50 cycles
8. Resistance to soldering heat	No deformation of any component. No affect on contacts.	Reflow: At the recommended temperature profile Manual soldering: 300°C for 3 seconds

Note 1: Includes temperature rise caused by current flow.

Note 2: The term "storage" refers to products stored for long period of time prior to mounting and use. Operating Temperature Range and Humidity range covers non-conducting condition of installed connectors in storage, shipment or during transportation.

Materials

Product	Part	Material	Finish	Remarks
Receptacles Plugs	Insulator	LCP	Color: Black	UL94V-0
	Contacts	Copper alloy	Gold plated	-
	Metal fittings	Brass	Tin plated	-

Ordering Information

Receptacles / Plugs

DF18 **C** — ***** **DS** — **0.4** **V** (******)
① ② ③ ④ ⑤ ⑥ ⑦

① Series name: DF18	③ Number of Contacts: 20, 30, 40, 50, 60, 70, 80, 100, 120	⑥ Terminal type V: SMT vertical mounting type
② Hold-down bracket type B: With metal hold-down, (receptacles only) C: With added hold-down contacts D: With added hold-down contacts, increased Removal Force Type(receptacle only) E: With added hold-down contacts, increased Removal Force Type(receptacle only)	④ Connector type DS: Double-row receptacle DP: Double-row plug ⑤ Contact pitch 0.4 mm	⑦ Packaging type (51): Plug, embossed tape packaging (2,000 pieces per reel) (81): Receptacle, embossed tape packaging (2,000 pieces per reel)

■ Receptacles (with metal hold-down)

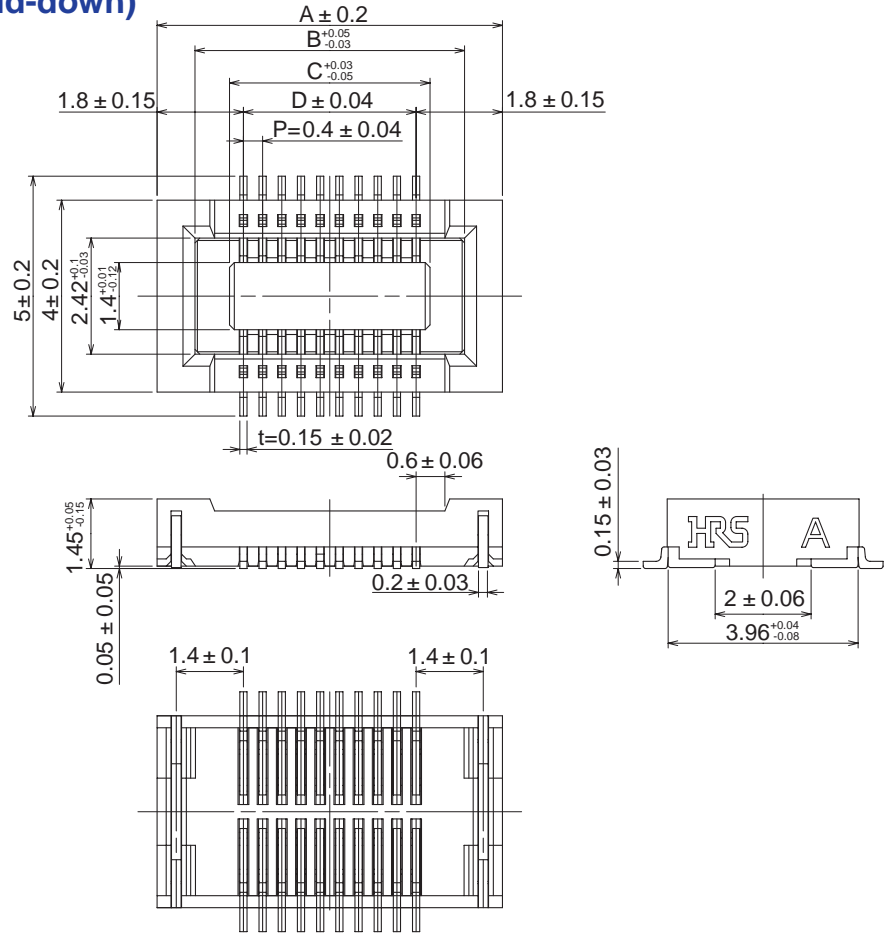
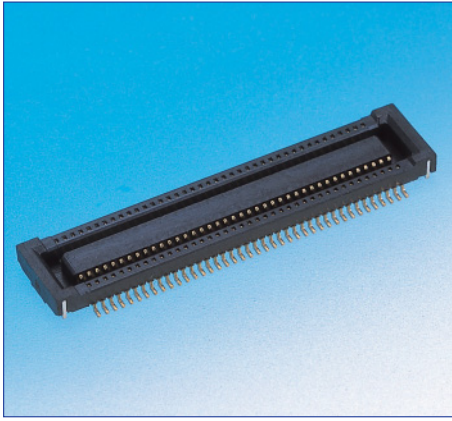

◆ PCB mounting pattern

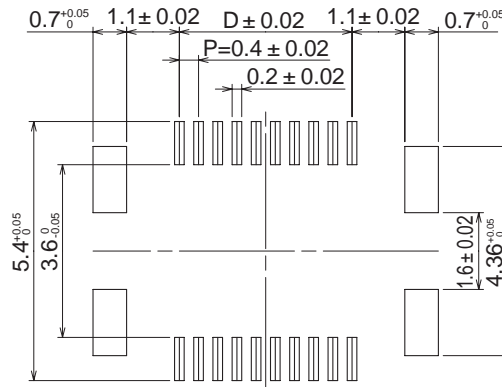

Unit: mm

Part Number	CL No.	Number of Contacts	A	B	C	D
DF18B - 20DS-0.4V (81)	684-0021-3-81	20	7.20	5.62	4.18	3.60
DF18B - 30DS-0.4V (81)	684-0022-6-81	30	9.20	7.62	6.18	5.60
DF18B - 40DS-0.4V (81)	684-0023-9-81	40	11.20	9.62	8.18	7.60
DF18B - 50DS-0.4V (81)	684-0005-7-81	50	13.20	11.62	10.18	9.60
DF18B - 60DS-0.4V (81)	684-0006-0-81	60	15.20	13.62	12.18	11.60
DF18B - 70DS-0.4V (81)	684-0024-1-81	70	17.20	15.62	14.18	13.60
DF18B - 80DS-0.4V (81)	Reserved for product expansion	80	19.20	17.62	16.18	15.60
DF18B-100DS-0.4V (81)	684-0008-5-81	100	23.20	21.62	20.18	19.60
DF18B-120DS-0.4V (81)	Reserved for product expansion	120	27.20	25.62	24.18	23.60

Note: Embossed tape reel packaging(2,000 pieces/reel)
Order by the number of reels.

Receptacles (without metal hold-down)

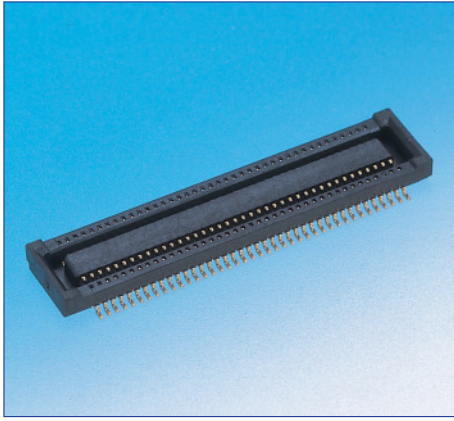

Note: Please specify metal fittings when connecting rigid PCB's.

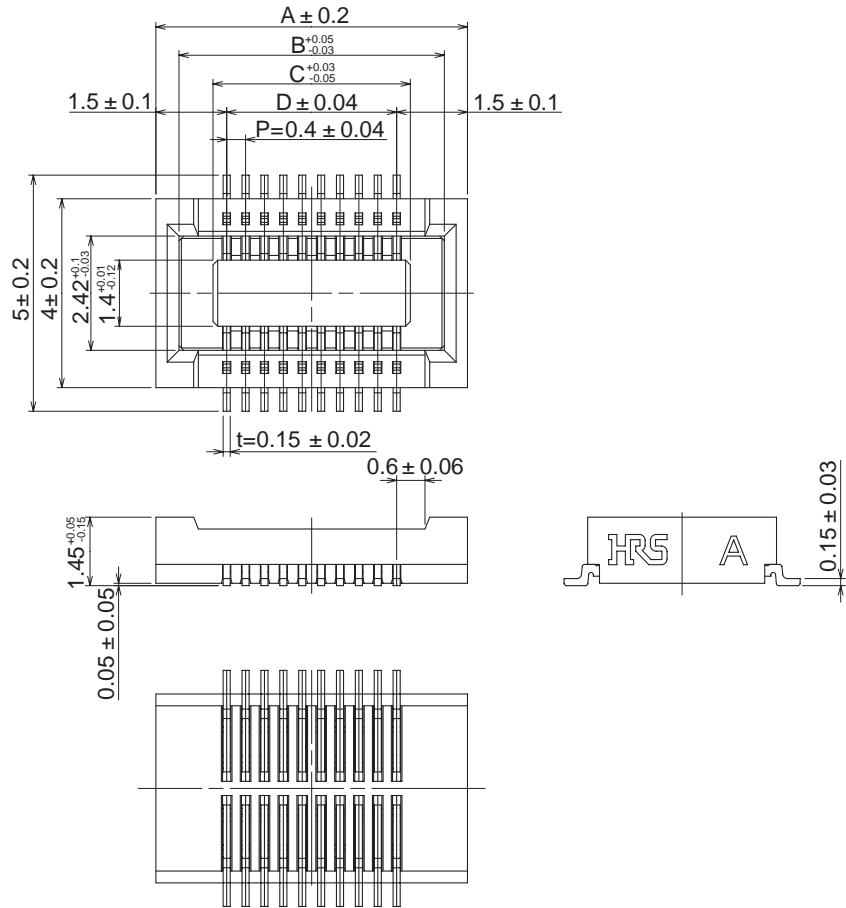

PCB mounting pattern

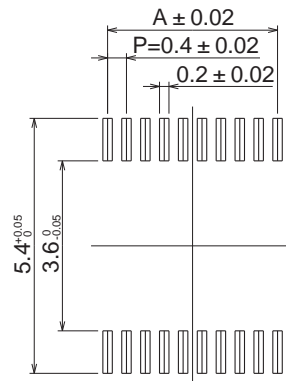

Unit: mm

Part Number	CL No.	Number of Contacts	A
DF18C - 20DS-0.4V (81)	684-0017-6-81	20	3.60
DF18C - 30DS-0.4V (81)	684-0018-9-81	30	5.60
DF18C - 40DS-0.4V (81)	684-0019-1-81	40	7.60
DF18C - 50DS-0.4V (81)	684-0001-6-81	50	9.60
DF18C - 60DS-0.4V (81)	684-0002-9-81	60	11.60
DF18C - 70DS-0.4V (81)	684-0020-0-81	70	13.60
DF18C - 80DS-0.4V (81)	684-0003-1-81	80	15.60
DF18C-100DS-0.4V (81)	684-0004-4-81	100	19.60
DF18C-120DS-0.4V (81)	684-0013-5-81	120	23.60

Note: Embossed tape reel packaging (2,000 pieces/reel)
Order by the number of reels.

Plugs (with metal hold-down terminals)

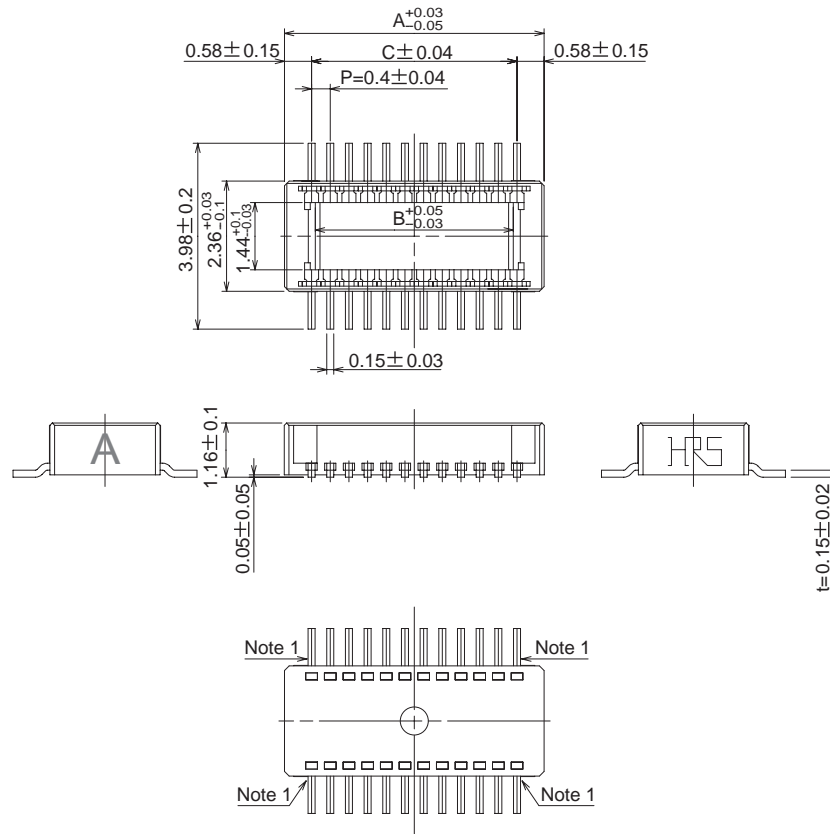
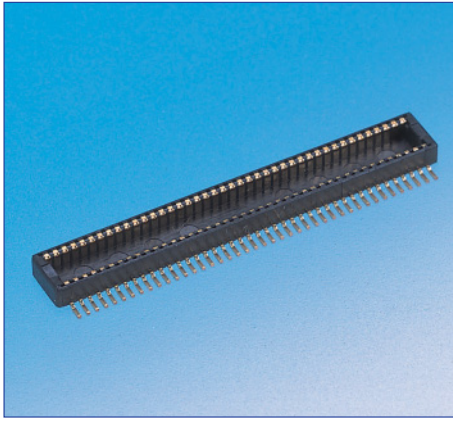

PCB mounting pattern

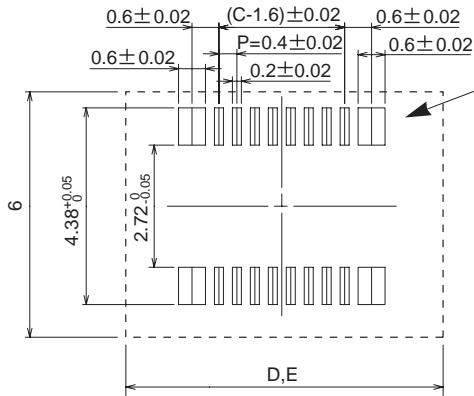

Added hold-down contacts

Note 1: The terminals located at each of the 4 corners provide additional hold to the board's mounting surface and are not part of electrical connection.

When counting the terminal leads the number of actual electrical circuits is lower by 4. Example: Connector with 24 terminal leads will have 20 actual electrical connections when mated with corresponding part.

Note 2: Please note that mounting of parts within the area of the broken lines will prevent the connector from mating.

D: When the corresponding connector is DF18B- *DS-0.4V (**)

E: When the corresponding connector is DF18C- *DS-0.4V (**)

Plugs (with metal hold-down terminals, increased Removal Force)

Part Number	CL No.	Number of Contacts	A	B	C	D	E
DF18D-20DP-0.4V (51)	684-0029-5-51	20	5.56	4.24	4.40	7.20	6.60
DF18D-30DP-0.4V (51)	684-0030-4-51	30	7.56	6.24	6.40	9.20	8.60

Plugs (with metal hold-down terminals, increased Removal Force)

Part Number	CL No.	Number of Contacts	A	B	C	D	E
DF18E-40DP-0.4V (51)	684-0031-7-51	40	9.56	8.24	8.40	11.20	10.60
DF18E-50DP-0.4V (51)	684-0032-0-51	50	11.56	10.24	10.40	13.20	12.60

Plugs (with metal hold-down terminals)

Part Number	CL No.	Number of Contacts	A	B	C	D	E
DF18C - 60DP-0.4V (51)	684-0010-7-51	60	13.56	12.24	12.40	15.20	14.60
DF18C - 70DP-0.4V (51)	684-0028-2-51	70	15.56	14.24	14.40	17.20	16.60
DF18C - 80DP-0.4V (51)	684-0011-0-51	80	17.56	16.24	16.40	19.20	18.60
DF18C-100DP-0.4V (51)	684-0012-2-51	100	21.56	20.24	20.40	23.20	22.60
DF18C-120DP-0.4V (51)	684-0014-8-51	120	25.56	24.24	24.40	27.20	26.60

◆ Embossed Carrier Tape Dimensions

● Receptacles

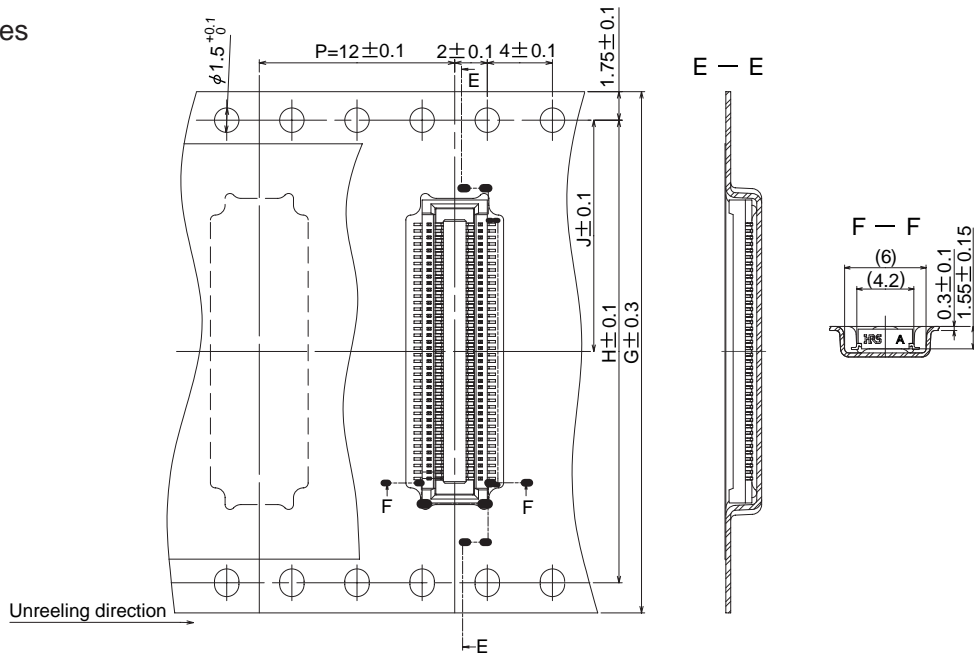

● Reel dimensions

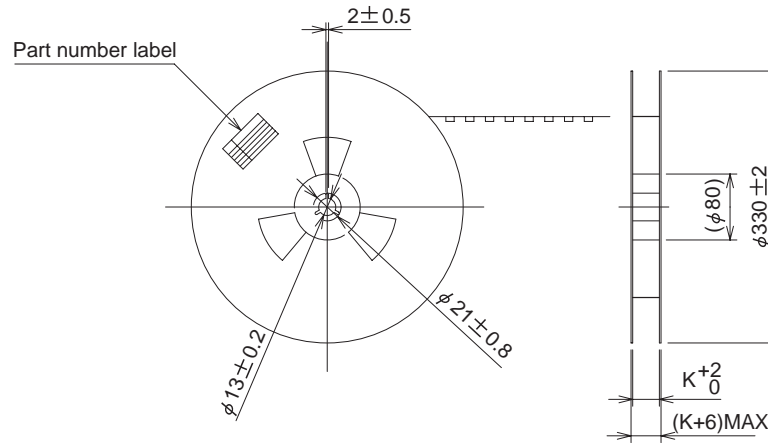

Part Number	G	H	J	K
DF18B - 20DS-0.4V	16.0	-	7.5	16.4
DF18C - 20DS-0.4V				
DF18B - 30DS-0.4V	24.0	-	11.5	24.4
DF18C - 30DS-0.4V	16.0	-	7.5	16.4
DF18B - 40DS-0.4V	24.0	-	11.5	24.4
DF18C - 40DS-0.4V				
DF18B - 50DS-0.4V	24.0	-	11.5	24.4
DF18C - 50DS-0.4V				
DF18B - 60DS-0.4V	24.0	-	11.5	24.4
DF18C - 60DS-0.4V				
DF18B - 70DS-0.4V	32.0	28.4	14.2	32.4
DF18C - 70DS-0.4V	24.0	-	11.5	24.4
DF18B - 80DS-0.4V	32.0	28.4	14.2	32.4
DF18C - 80DS-0.4V				
DF18B-100DS-0.4V	44.0	40.4	20.2	44.4
DF18C-100DS-0.4V				
DF18B-120DS-0.4V	44.0	40.4	20.2	44.4
DF18C-120DS-0.4V				

Note: Bottom side feed holes are added to embossed tape when G = 32.0 or greater.

● Plugs

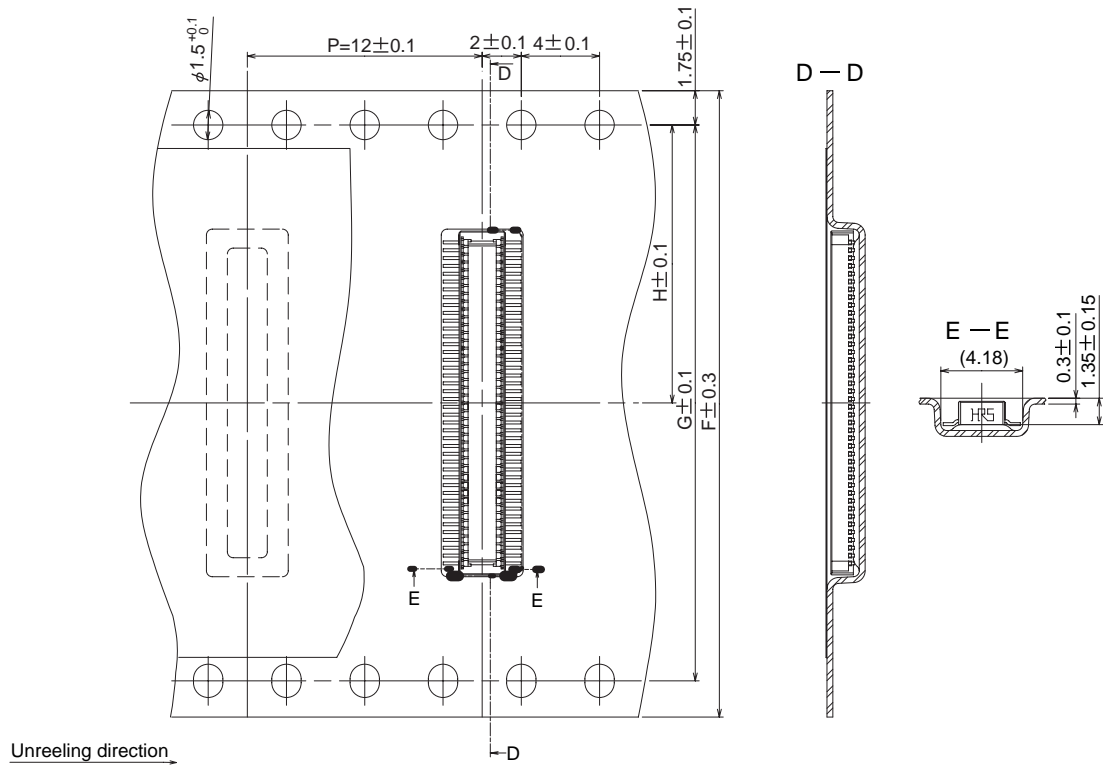

● Reel dimensions

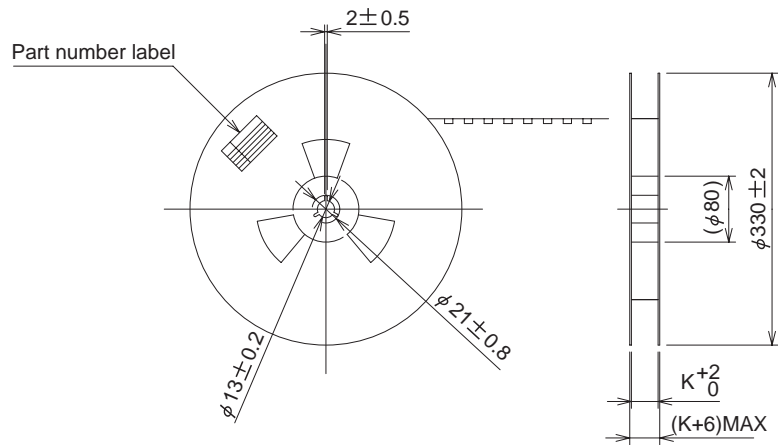

Part Number	F	G	H	K
DF18D - 20DP-0.4V	16.0	-	7.5	16.4
DF18D - 30DP-0.4V	16.0	-	7.5	16.4
DF18E - 40DP-0.4V	24.0	-	11.5	24.4
DF18E - 50DP-0.4V	24.0	-	11.5	24.4
DF18C - 60DP-0.4V	24.0	-	11.5	24.4
DF18C - 70DP-0.4V	24.0	-	11.5	24.4
DF18C - 80DP-0.4V	32.0	28.4	14.2	32.4
DF18C-100DP-0.4V	44.0	40.4	20.2	44.4
DF18C-120DP-0.4V	44.0	40.4	20.2	44.4

Note: Bottom side feed holes are added to embossed tape when $F = 32.0$ or greater.

◆ Usage Recommendations

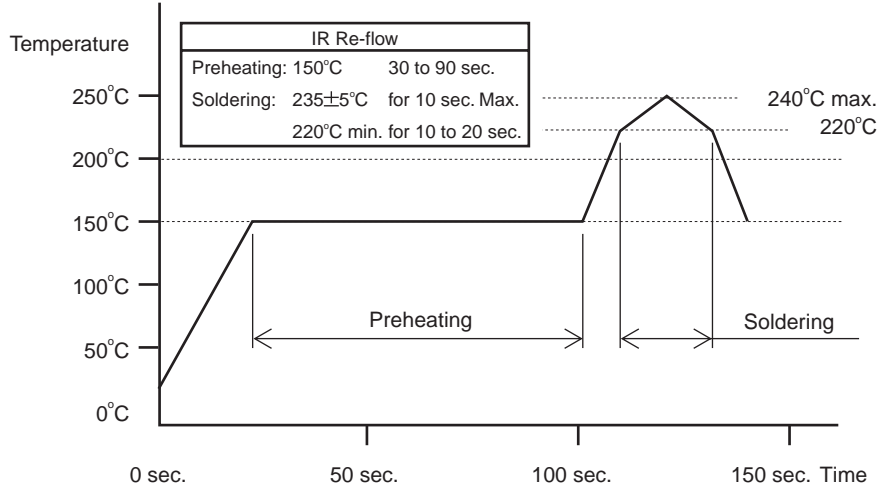
<p>1. Recommended temperature profile</p>	 <p>Note 1: Up to 2 cycles of reflow soldering are possible under the same conditions, provided that there is a return to normal temperature between the first and second cycle.</p> <p>Note 2: The temperature profile indicates the board surface temperature at the point of contacts with the connector terminals (for surface mounted plug assembly).</p>
<p>2. Recommended soldering conditions</p>	<p>Soldering temperature: $290 \pm 10^{\circ}\text{C}$, soldering time: within 2 sec.</p>
<p>3. Recommended screen thickness and open area ratio (Pattern area ratio)</p>	<p>Thickness: 0.12 mm Open area ratio: 70%</p>
<p>4. Board warping</p>	<p>Maximum of 0.03mm at the connector center section, with both ends of the connector as reference points.</p>
<p>5. Cleaning conditions</p>	<p>Refer to "Nylon Connector Use Handbook".</p>
<p>6. Precautions</p>	<ul style="list-style-type: none"> ■ Excessive twisting when mating/un-mating may cause damage to the connectors. ■ Specify receptacles with the metal hold-down when connecting rigid (non- flexible) printed circuit boards.

USA:

HIROSE ELECTRIC U.S.A., INC.

2688 Westhills Court, Simi Valley, CA 93065-6235

Phone : 1 805 522 7958

Fax : 1 805 522 3217

<http://www.hiroseusa.com>

UNITED KINGDOM:

HIROSE ELECTRIC UK LTD.

Crownhill Business Centre 22 Vincent Avenue

Crownhill, Milton Keynes MK8 OAB

Phone : 44 1908 305400

Fax : 44 1908 305401

<http://www.hirose.co.uk>

HONG KONG:

HIROSE ELECTRIC CO., LTD.

Unit 506, Energy Plaza. 92 Granville Road, Tsim Sha

Tsui East, Kowloon

Phone : 852 2803 5338

Fax : 852 2591 6560

GERMANY:

HIROSE ELECTRIC GmbH

Zeppelinstrasse-42 D-73760 Ostfildern Kemnat

Phone : 49 711 4560021

Fax : 49 711 4560729

<http://www.hirose.de>

KOREA:

HIROSE KOREA CO., LTD.

(#2NA311, Shihwa Industrial Complex),

1261-10, Jeoungwhang-Dong, Shihung-City, Kyunggi-Do

Phone : 886 2 2557 7351, 7352

Fax : 886 2 2552 9851

<http://www.hirose.co.kr>

TAIWAN:

HIROSE ELECTRIC TAIWAN CO., LTD.

No.28 Lane 247 Sec. 2 Yen Ping N.Rd.Taipei

Phone : 886 2 2557 7351, 7352

Fax : 886 2 2552 9851

THE NETHERLANDS:

HIROSE ELECTRIC B.V.

Beechavenue 46.1119PV

Schiphol-Rijk

Phone : 31 20 6557 460

Fax : 31 20 6557 469

<http://www.hiroseurope.com>

CHINA:

HIROSE ELECTRIC TRADING(SHANGHAI) CO., LTD.

3705,Bund Center,222 Yan An Road(E),

Shanghai 20002

Phone : 86 21 6335 2538

Fax : 86 21 6335 0767

SINGAPORE:

HIROSE ELECTRIC CO., LTD.

10 Anson Road #34-13 International Plaza 079903

Phone : 65 6324 6113

Fax : 65 6324 6123



HIROSE ELECTRIC CO., LTD.

5-23,OSAKI 5-CHOME,SHINAGAWA-KU,TOKYO 141-8587,JAPAN

PHONE: 81-3-3491-9741, FAX: 81-3-3493-2933

<http://www.hirose.com>

<http://www.hirose-connectors.com>