

INTRODUCTION

The S1A0427B01 is a monolithic integrated circuit designed for portable AM/FM radios or AM/FM clock radios.

FUNCTIONS

- AM RF & MIX
- AM AGC
- AM/FM DET
- Regulator
- AM Local OSC
- AM/FM IF AMP
- Audio Power AMP
- FM AFC Control

16-DIP-300A

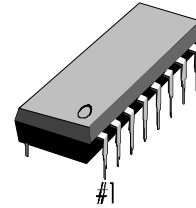

FEATURE

- Portable AM/FM 1-chip radio
- Wide operating supply voltage range: $V_{CC} = 3V - 12V$ (Approximately)
(Depending on the internal regulator tolerance)
- Recommended operating supply voltage:
 $V_{CC} = 4.5V - 9V$

R_L \ V_{CC}	4.5V	6.0V	7.5V	9.0V	Line Operated
8 Ω	O	O	O	X	X
16 Ω	O	O	O	O	X
45 Ω	O	O	O	O	O

- When using the AC line as an internal shunt regulator mode, it is possible to use a low cost application without a transformer (approximately 42mA)
- IF AMP gain is determined by the DC voltage appearing at IC Pin 16.
- Power output: $P_C = 0.28W$ (Min.) at THD = 10% ($V_{CC} = 5.5V/8\Omega$).

ORDERING INFORMATION

Device	Package	Operating Temperature
S1A0427B01-D0B0	16-DIP-300A	20°C - +70°C

BLOCK DIAGRAM

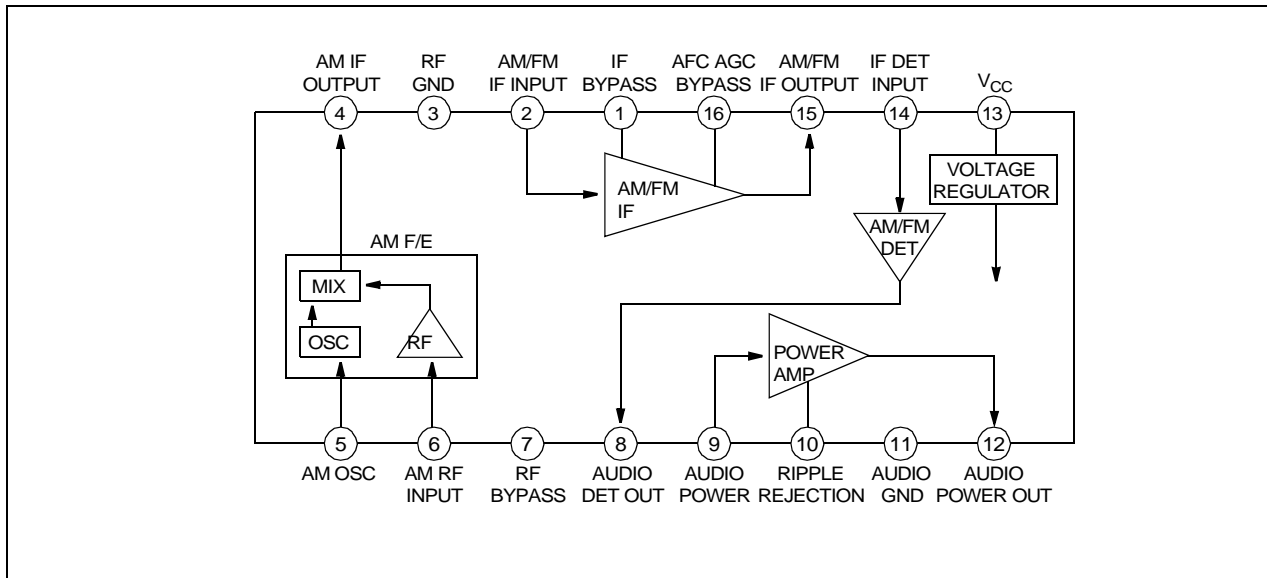
ABSOLUTE MAXIMUM RATINGS ($T_a = 25^\circ\text{C}$)

Character istic	Symbol	Value	Unit
Supply Voltage	V_{CC}	13	V
Power Dissipation	P_D	600	mW
Supply Current	I_{CC}	44	mA
Thermal Resistance Junction to Ambient	R_{EJA}	100	$^\circ\text{C}/\text{W}$
Operating Temperature	T_{OPR}	-20 – +70	$^\circ\text{C}$
Storage Temperature	T_{STG}	-55 – +150	$^\circ\text{C}$

ELECTRICAL CHARACTERISTICS

($T_a = 25^\circ\text{C}$, $V_{CC} = 5.5\text{V}$, $f_m = 1\text{kHz}$, AM: $f = 1\text{MHz}$, 30% Mod, FM: $f = 10.7\text{MHz}$
 $\Delta f = 22.5\text{kHz}$, unless otherwise specified)

Characteristic		Symbol	Test Conditions	Min.	Typ.	Max.	Unit
FM	Quiescent Circuit Current	I_{CCQ}	SW: FM, $V_{CC} = 3\text{V}$	7	12	17	mA
			SW: FM, $V_{CC} = 9\text{V}$	10	17	23	
	Pin 16 Terminal Voltage	$V_{16(\text{FM})}$	SW: FM, $V_{CC} = 9\text{V}$, $V_I = 0$	2.0	2.4	3.1	V
	-3 dB Limiting Sensitivity	$V_{I(\text{LIM})}$	SW: FM, -3dB $V_{16} = 2.4\text{V}$, V_R Min	-	57	-	dB
AM	Internal Regulated Vtg.	V_{CC}	SW: AM, $I_{CC} = 42\text{mA}$	12	13.2	14.0	V
	Pin 16 Voltage	$V_{16(\text{AM})}$	SW: AM, $V_{CC} = 9\text{V}$, $V_I = 0$	1.4	-	1.9	V
	Maximum Sensitivity	S_{MAX}	SW: AM, $V_{CC} = 12\text{V}$ $V_I = 37\text{dB}\mu$, $R_L = 8\Omega$	1.5	3.0	-	V
	Signal to Noise Ratio	S/N	$V_I = 37.5\text{dB}\mu$, $R_L = 8\Omega$ $P_O = 50\text{mW}$	15	20	-	dB
PWR AMP	Output Power	P_O	$f = 1\text{kHz}$, THD = 10% V_R Min, $R_L = 8\Omega$	0.28	-	-	W
	Total Harmonic Distortion	THD	$I_{CC} = 42\text{mA}$, $R_L = 45\Omega$ $f = 1\text{kHz}$, $V_O = 2\text{V}$ V_R Min	-	0.5	4.0	%
	Voltage gain	G_V	$f = 1\text{kHz}$, $R_L = 8\Omega$, $P_O = 50\text{mW}$	-	41	-	dB

TEST CIRCUIT

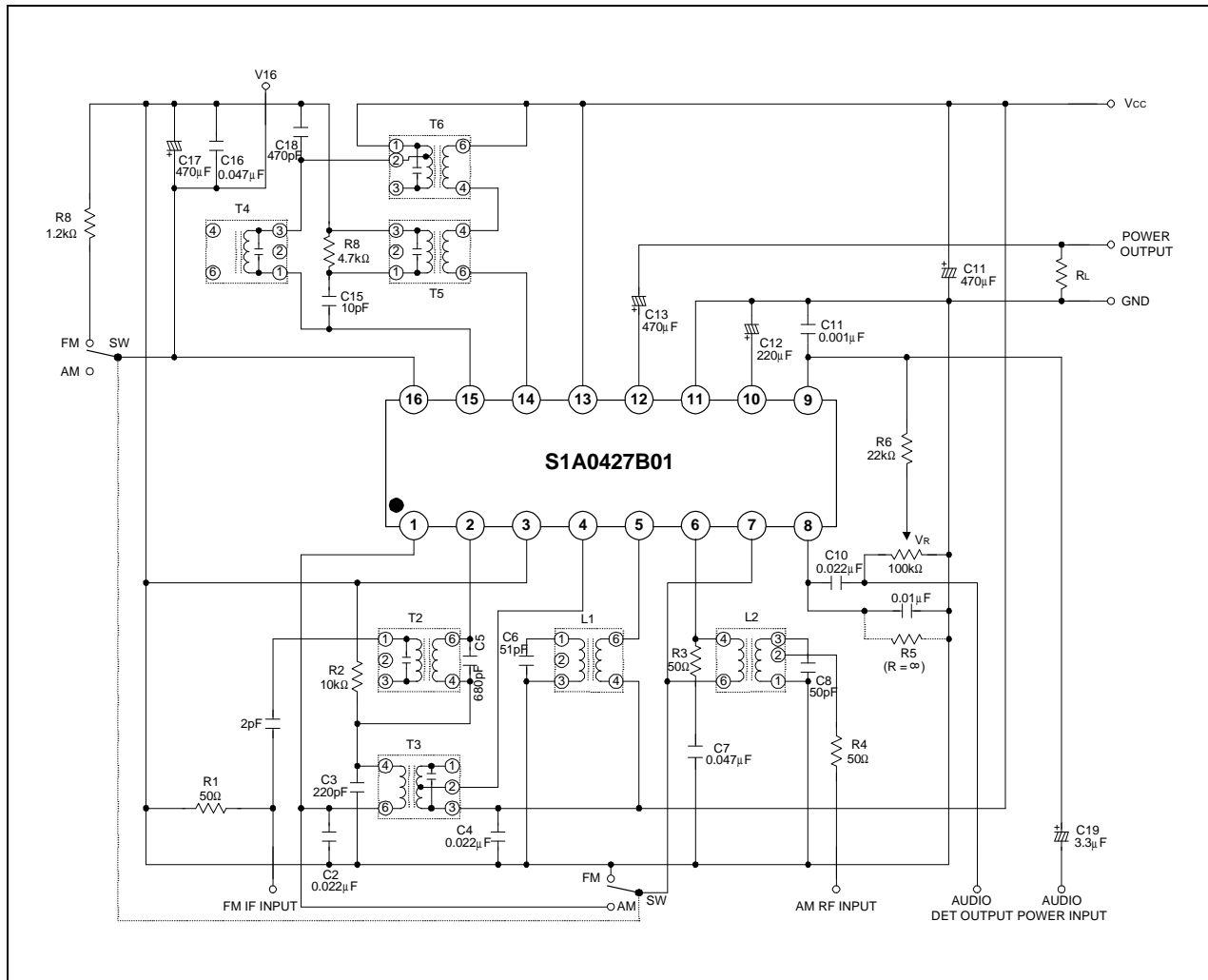

APPLICATION INFORMATION

— EXTERNAL COMPONENTS

Part Number	Purpose	Typical	Influence	
			Smaller Than Typ	Greater Than Typ
R5	Am gain Control	47k Ω (33K – ∞)	Low AM gain	AGC Distortion increase, High gain
R7	FM detector damper	4.7k Ω	Low detector output, stable IF gain, low FM gain	Sharp IF AMP curve
R8	FM gain adjust	470 Ω	Low FM gain	High gain, but noise increase
C2	IF bypass	0.022 μ F	Should not be less than 0.005 μ F	High IF Gain, S/N ratio degrade
C4	IF filter	0.022 μ F	Removal may cause IF oscillation	No influence
C7	AM bypass	0.047 μ F	Low gain	Using over 1 will cause FM distortion at small signal
C9	Detector filter	0.01 μ F	Unstable IF AMP oscillation	Poor FM frequency response
C10	Audio coupling	0.022 μ F	Lower sensitivity, poor low frequency response	Bass boost affects de-emphasis curve
C11	Audio Input High-cut	0.001 μ F	Audio oscillation	Poor response
C12	Ripple filter	220 μ F	Poor frequency response & Low gain	Improve AC Hum
C13	Audio output coupling	470 μ F	Poor low frequency response	Can achieve optimum output power
C14	Power line filter	470 μ F	Poor AC Hum	Improve AC Hum
C15	FM detector phase-shift	10pF	Narrow IF bandwidth	Wide IF bandwidth
C16	High freq. (IF) bypass	0.047 μ F	Removal will cause fm oscillation	No influence
C17	AN AGC time constant and high frequency (IF) bypass	0.047 μ F	Charging not recommended	–

FUNCTION DESCRIPTION (PIN 16 DC VOLTAGE)

1. IF Gain Grouping Table

(1) Test Condition: $V_{CC} = 9V$ (Pin 13).

Pin 8 resistance (AM) = $47k\Omega$

Pin 16 resistance (FM) = $1.2k\Omega$

(2) Grouping Table

V16(FM)	V16(AM)	1.4 - 1.7 V
2.4 - 2.85V		2B

2. IF gain is determined by DC voltage appeared at IC Pin 16.

The DC voltage at Pin 16 to the following values:

AM = 1.4 - 1.65V (DC)

FM = 1.9 - 2.10V (DC)

AM gain can be adjusted by the loading resistor value of Pin 8 (AM) from $33k\Omega$ to infinity.

FM gain can be adjusted by the loading resistor value of Pin 16 (FM) from $3k\Omega$ to 680Ω .

Recommended resistance (Pin 8, Pin 16).

Pin 8 (AM) = $47k\Omega$

Pin 16 (FM) = $470k\Omega$

COIL SPECIFICATION 1

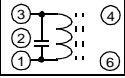
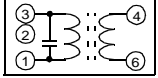
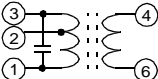
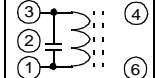
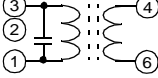
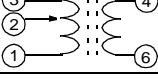
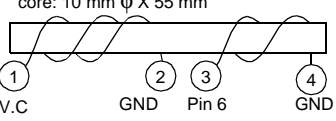
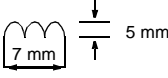
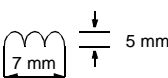
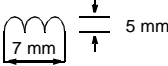
Coil No.	f	Q _O	Turns		C _O	Connections (KOREA TOKO)
T1	10.7MHz	120	1-3	8T	150 pF	
T2	10.7MHz	70 min	1-3	11T	75 ± 5 pF	
			4-6	2T		
T3 (T6)	455kHz	80 min	1-2	91T	180 ± 5 pF	
			2-3	55T		
			4-6	6T		
T4	10.7MHz	45 min	1-3	11T	82 ± 3 pF	
T5	10.7MHz	25 min	1-3	7T	180 pF	
			4-6	7T		
L1	AM Local Oscillator	90 min	1-3	86T		
			4-6	7T		
L2	AM ANT	200	1-2 (L = 560μH)	138T		
			3-4	9T		
L3	FM ANT		0.8mmφ UEW TAP	5T		
				0.5T		
L4	Trap		0.32mmφ UEW	10T		
L5	FM Oscillator		0.8mmφ UEW	4T	-	

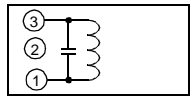
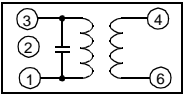
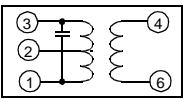
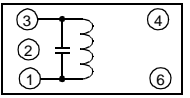
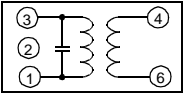
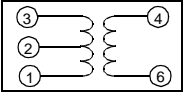
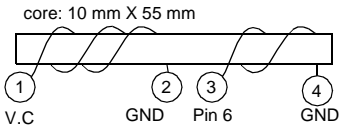
Coil No.	f	Q ₀	Turns		C.L.	Connections (KWANG SUNG PART NO)
T1	10.7MHz	120	1-3	8T	150pF	 <p>KSI-FD5</p>
T2	10.7MHz	70min	1-3	11T	75pF	 <p>KSI-FA2</p>
			4-6	2T		
T3 (T6)	455kHz	80min	1-2	91T	180pF	 <p>KSI-AA4</p>
			2-3	55T		
			4-6	6T		
T4	10.7MHz	45min	1-3	11T	82pF	 <p>KSI-FD4</p>
T5	10.7MHz	45min	1-3	7T	180pF	 <p>KSI-FA4</p>
			4-6	7T		
L1	AM Local Oscillator	90min	1-3	86T		 <p>KSI-AO4</p>
			4-6	7T		
L2	AM ANT	200	1-2 L = 560uH	138T		 <p>KSA-ANT560</p>
			4-6	9T		

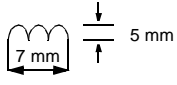
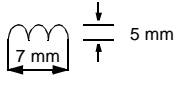
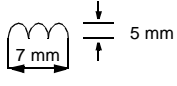
Coil No.	f	Q ₀	Turns		C.L.	Connections (KWANG SUNG PART NO)
L3	FM ANT		0.8mm ϕ UEW	5T		 KSS-SP5
		0.5T				
L4	Trap		0.32mm ϕ UEW	10T		 KSS-SP4
L5	FM Oscillator		0.8mm ϕ UEW	4T		 KSS-SP3

COIL SPECIFICATION 2

Coil No.	f	Q ₀	Turns		C.L.	Connections
			1-3			
T1	10.7MHz	90	1-3	11	82pF	
			4-6	3		
T2	10.7MHz	60	1-3	5	390pF	
			4-6	2		
T3	455kHz	100	1-2	127	180pF	
			2-3	28		
			4-6	10		
T4	10.7MHz	45 (Min)	1-3	11	82 pF	
T5	10.7MHz	25 (Min)	1-3	7	180pF	
			4-6	7		
T6	455kHz	100	1-2	50	390pF	
			2-3	50		
L6	796kHz	100	1-3	100	360μH	
			4-6	10		

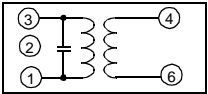
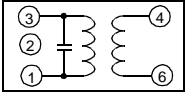
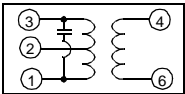
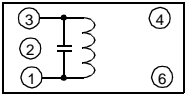
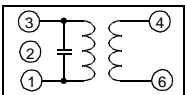
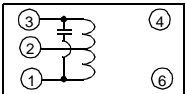
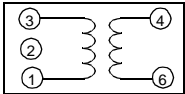
Coil No.	f	Q ₀	Turns		C.L.	Connections (KWANG SUNG PART NO)
			1-3	4-6		
T1	10.7MHz	90	11	3	82pF	 KSI-FA3
T2	10.7MHz	60	5	2	390pF	 KSI-FA5
T3	455kHz	100	1-2	127	180pF	 KSI-AA3
			2-3	28		
			4-6	10		
T4	10.7MHz	45min	1-3	11	82pF	 KSI-FD4
T5	10.7MHz	45min	1-3	7	180pF	 KSI-FA4
			4-6	7		
T6	455kHz	100	1-2	50	390pF	 KSI-AA2
			2-3	50		
L6	796kHz	100	1-3	100	360uH	 KSI-A03
			4-6	10		

NOTES