

SF1103B 285 MHz SAW Filter

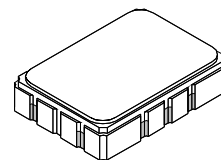

PRELIMINARY

- Designed for WCDMA 3G IF Applications
- Quartz Temperature Stability
- Small Size
- Hermetic 7 x 5 mm Surface-Mount Case



Characteristic	Sym	Min	Typ	Max	Units	Notes
Nominal Center Frequency	fc		285.000		MHz	1
Passband	Insertion Loss at fc	IL	14.5		dB	1, 2
		1 dB Passband	BW ₁	TBD		
	3 dB Passband	BW ₃	±2.5			
	Amplitude Ripple over fc ±1.9 MHz		0.8	1.0	dB _{P-P}	
	Group Delay Variation over fc ±1.9 MHz	GDV	70	150	nSP-P	
Rejection	fc-25 to fc-5.0 and fc+5.0 to fc+25 MHz	40	42		dB	1, 2, 3
Operating Temperature Range	T _A	-20		+80	°C	1
Matching to Unbalanced 50 Ω	External L-C					
Case Style	SMP-03 7 x 5 mm Nominal Footprint					
Lid Symbolization (YY = year, WW = week) See note 4	RFM SF1103B YYWW					

Absolute Maximum Ratings

Rating	Value	Units
Maximum Incident Power in Passband	+10	dBm
Max. DC voltage between any 2 terminals	30	VDC
Storage Temperature Range	-40 to +85	°C
Max Soldering Profile	235°C for 90 s	

Electrical Connections

Connection	Terminals
Port 1 Hot	10
Port 1 Gnd Return	1
Port 2 Hot	5
Port 2 Gnd Return	6
Case Ground	All others

Notes:

1. Unless noted otherwise, all specifications apply over the operating temperature range with filter soldered to the specified demonstration board with impedance matching to 50 Ω and measured with 50 Ω network analyzer.
2. Unless noted otherwise, all frequency specifications are referenced to the nominal center frequency, fc.
3. Rejection is measured as attenuation below the minimum IL point in the passband. Rejection in final user application is dependent on PCB layout and external impedance matching design. See Application Note No. 42 for details.
4. "LRIP" or "L" after the part number indicates "low rate initial production" and "ENG" or "E" indicates "engineering prototypes."
5. The design, manufacturing process, and specifications of this filter are subject to change.
6. Either Port 1 or Port 2 may be used for either input or output in the design. However, impedances and impedance matching may vary between Port 1 and Port 2, so that the filter must always be installed in one direction per the circuit design.
7. US and international patents may apply.
8. RFM, stylized RFM logo, and RF Monolithics, Inc. are registered trademarks of RF Monolithics, Inc.
9. ©Copyright 1999, RF Monolithics Inc.
10. Electrostatic Sensitive Device. Observe precautions for handling.



RF Monolithics, Inc.
4347 Sigma Road
Dallas, Texas 75244
USA

Phone: +1(972)233-2903
Fax: +1(972)387-8148
e-mail: info@rfm.com
Home page: www.rfm.com

European Sales Office
44 1963 251383
44 1963 251510

SF1103B 285 MHz SAW Filter

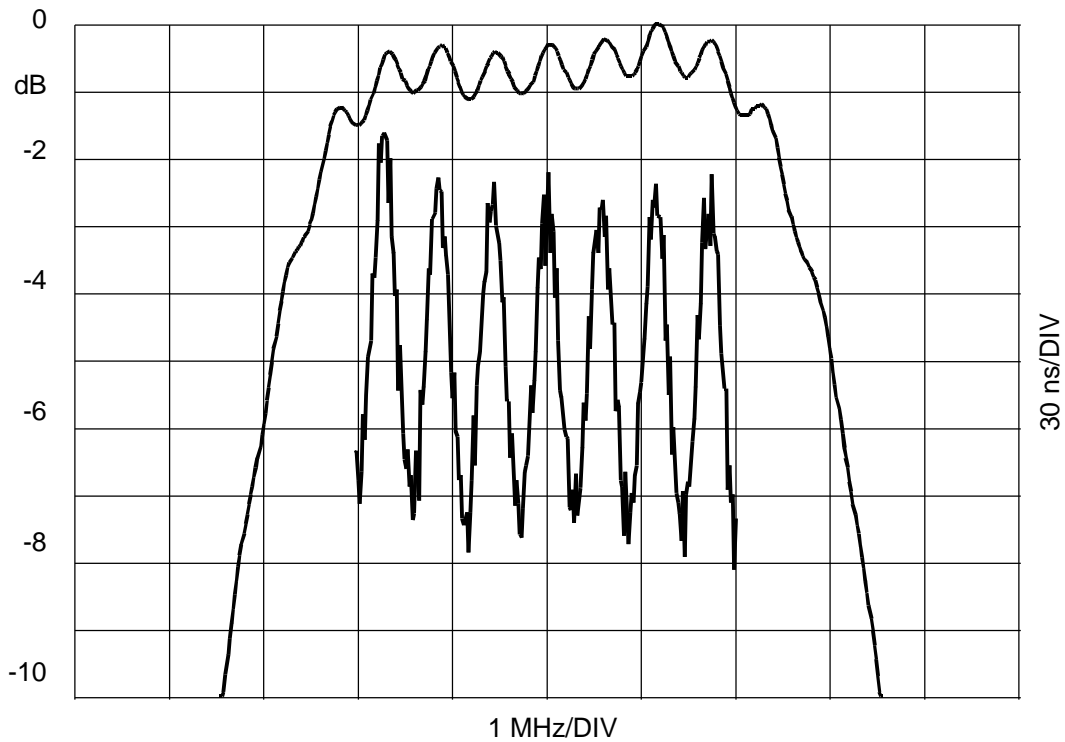
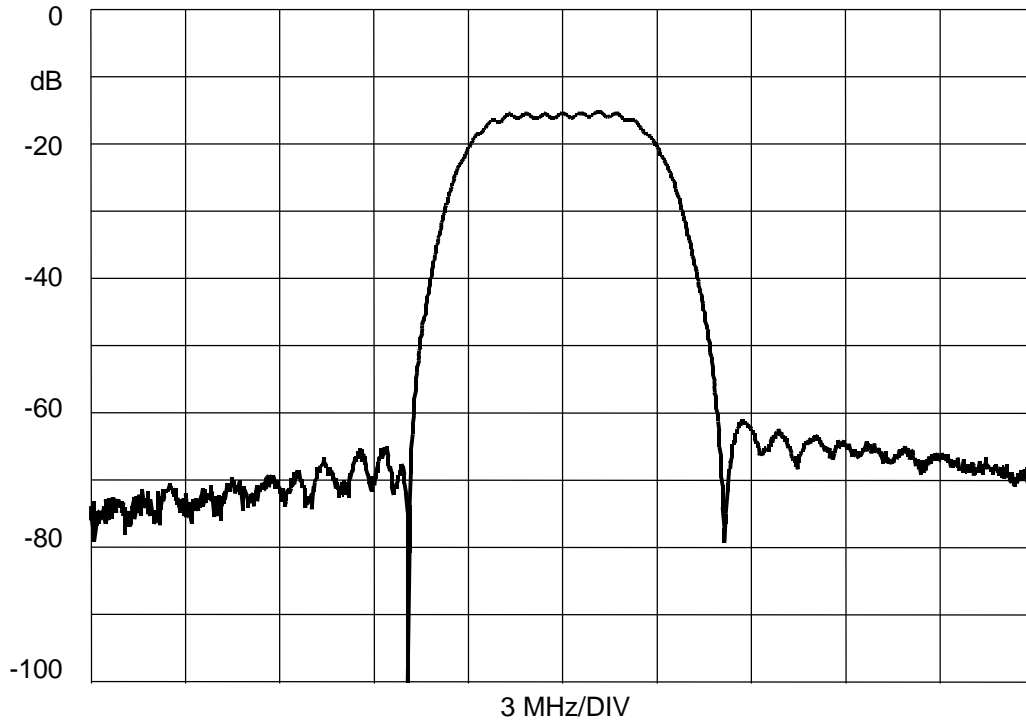

RF Monolithics, Inc.
4347 Sigma Road
Dallas, Texas 75244
USA

Phone: +1(972)233-2903
Fax: +1(972)387-8148
e-mail: info@rfm.com
Home page: www.rfm.com

European Sales Office
44 1963 251383
44 1963 251510

10-Terminal Ceramic Surface-Mount Case 7 x 5 mm Nominal Footprint

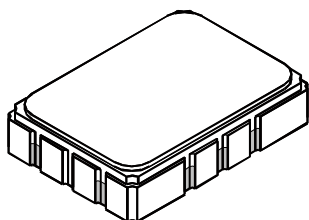

Dimension	mm			Inches		
	Min	Nom	Max	Min	Nom	Max
A	6.80	7.00	7.20	0.268	0.276	0.283
B	4.80	5.00	5.20	0.189	0.197	0.205
C		1.65	2.00		0.065	0.079
D		0.60			0.024	
E		2.54			0.100	
J		5.00			0.197	
K		3.00			0.118	
P		1.27			0.050	

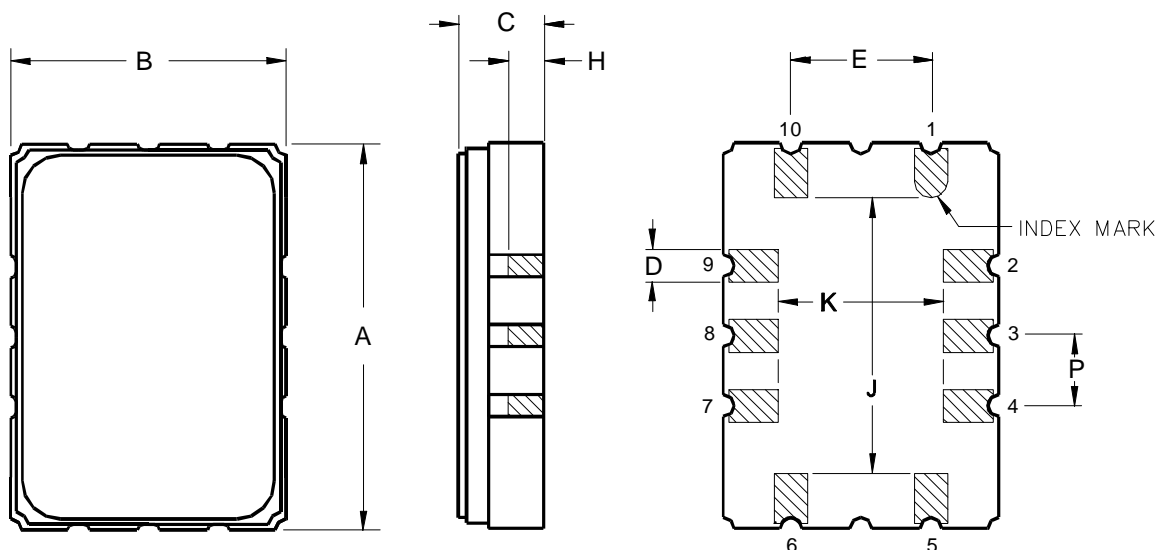

NOTES:

REV	ECN NO.	DESCRIPTION	APP/DATE
A	9755	INITIAL RELEASE	12jul01

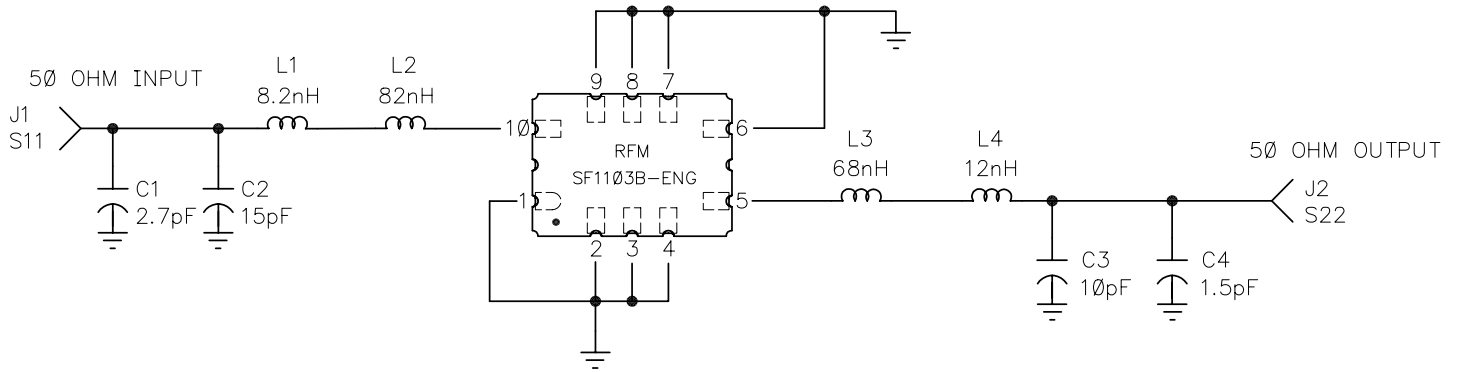

SCHEMATIC

D.U.T. VIEWED FROM TOP
 DOT INDICATES PIN 1 (INPUT)

DRAWN BY/DATE: J.F.Christopherson 12jul01

TITLE: ASSEMBLY DIAGRAM, SF1103B-DEMO

RF Monolithics, Inc.
 DALLAS, TEXAS 75244

SIZE
A

CODE IDENT
2U874

DWG. NO. SF1103B-100

REV
A

SHEET
 1/3

NOTES:

1. SOLDER MOUNT COMPONENTS AND CONNECTORS TO PCB1
2. ORIENT THE FLTR1 AND SOLDER IT DOWN TO THE BOARD AS SHOWN
3. LABEL AS SHOWN.

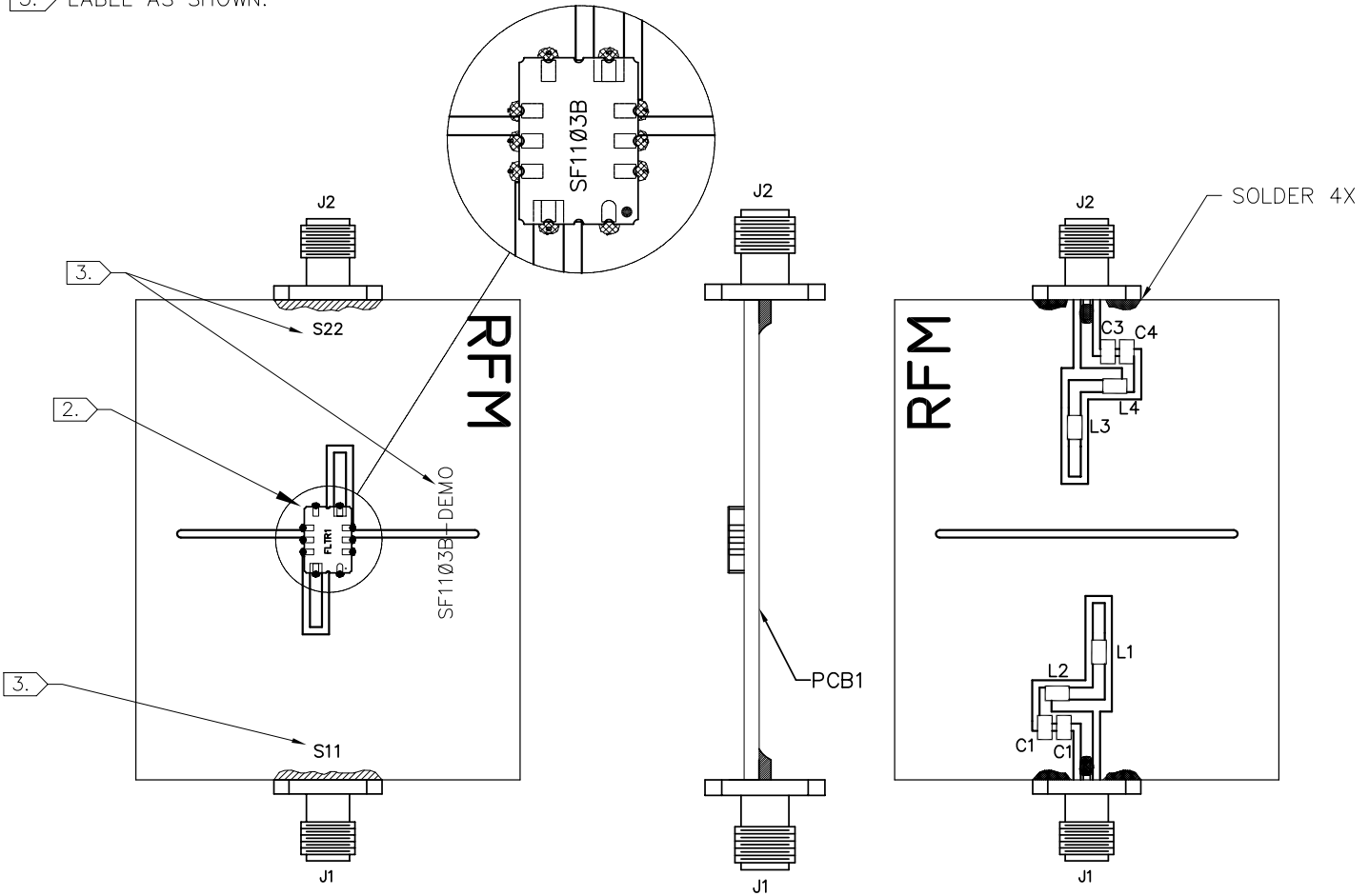

RF Monolithics, Inc.
DALLAS, TEXAS 75244

SIZE
A

CODE IDENT
2U874

DWG. NO. **SF1103B-100**

REV
A

SHEET
2

SF1103 Demo
5/1/01

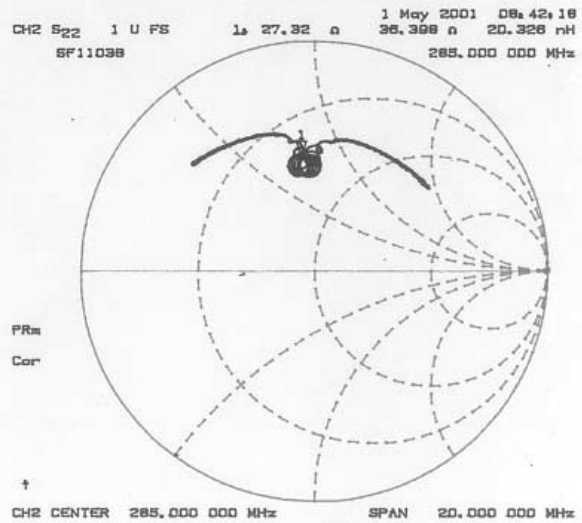
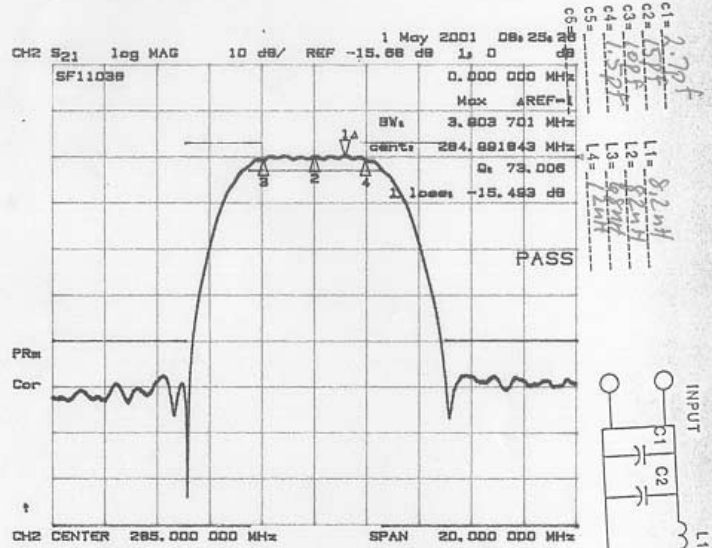
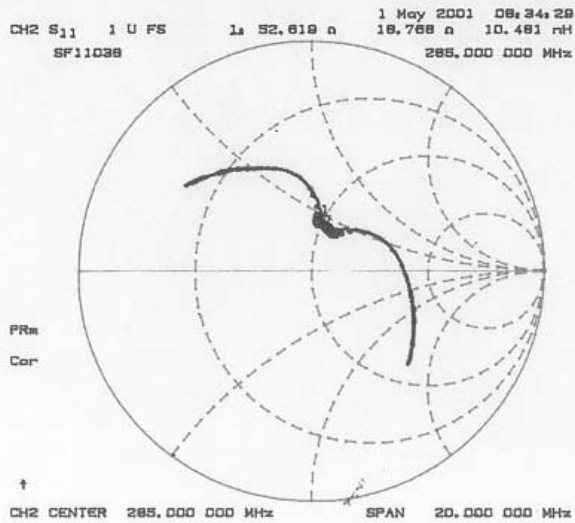
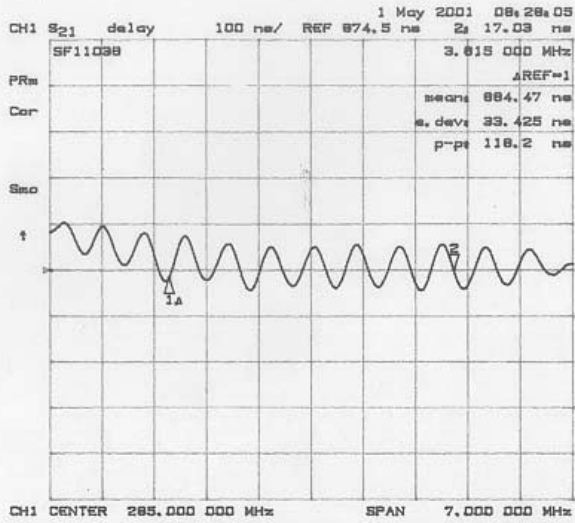

c1 = 2.7pF
c2 = 15pF
c3 = 45pF
c4 = 1.5pF
c5 = 1.5pF
L1 = 8.2nH
L2 = 8.2nH
L3 = 8.2nH
L4 = 1.5nH

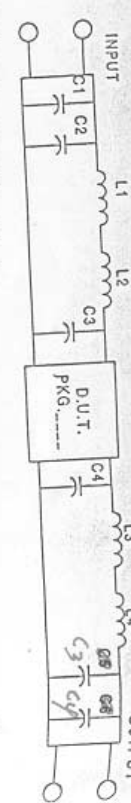

SF1103B-100 SHEET 3