

Applications

- ❑ 5GHz WLAN, IEEE 802.11a and HIPERLAN
- ❑ VSAT at 3.6 to 4.2 GHz
- ❑ Satellite Communications at 4.5 to 4.8 GHz
- ❑ 5 Gbps Clock Generator

Features

- ❑ Low Phase Noise, -141dBc/Hz at 1kHz offset
- ❑ Single Supply Voltage, 2.7 - 4.0 V
- ❑ Low Power Consumption, 42mW
- ❑ Power Down Mode, 0.2 μ A
- ❑ Compatible with common PLL synthesizer ICs
- ❑ 8-Lead Plastic SOIC Package

Product Description

The D602 is a SiGe divide-by-2 low noise static prescaler capable of operation up to 6.0 GHz. The D602 operates over a wide range of input frequencies and levels, and provides differential outputs for low noise operation with the common PLL style frequency synthesizer ICs.

The static nature of the prescaler prevents spurious generation.

The D602 prescaler can operate from either a single positive or single negative supply with power down mode for low standby power consumption.

Ordering Information

Type	Package	Remark
D602	8-lead SOIC	Plastic package

Functional Block Diagram

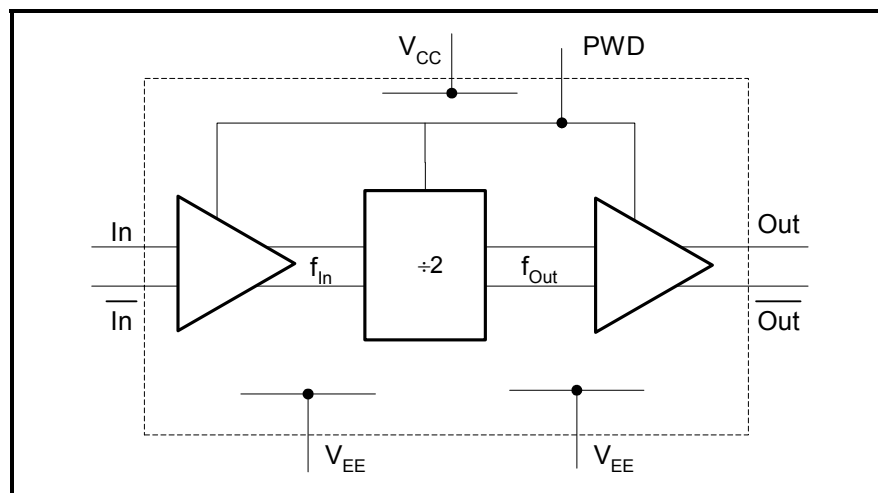

Pin Out Diagram

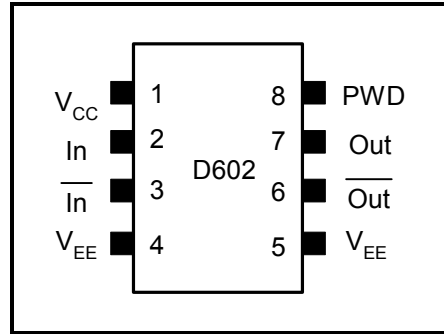

Pin Out Description

Pin No.	Name	Description
1	V_{CC}	Power Supply Voltage Input
2	In	Prescaler Input (internally-biased)
3	$\overline{\text{In}}$	Prescaler Complementary Input (internally-biased)
4	V_{EE}	Ground for Input (pins 4 and 5 must be connected to the same potential)
5	V_{EE}	Ground for Output (pins 4 and 5 must be connected to the same potential)
6	$\overline{\text{Out}}$	Complementary Output (open-collector)
7	Out	Output (open-collector)
8	PWD	Power Down high impedance CMOS input. When PWD is high, the part is powered down.

Absolute Maximum Ratings

Parameter	Min.	Max.	Unit
Supply Voltage	-0.3	+4.3	V
Voltage on any pin with respect to V_{EE}	-0.3	$V_{CC} + 0.3$	V
Differential input voltage	-2.0	+2.0	V
Storage Temperature	-65	+150	$^{\circ}\text{C}$

Operation in excess of any one of above Absolute Maximum Ratings may result in permanent damage. This device is a high performance RF integrated and is ESD sensitive. The RF inputs on this device are Class 0 ESD rated, therefore suitable precaution should be taken during handling, assembly and testing.

Electrical Characteristics

$V_{CC} = 3.0V; -40^{\circ}C < T_A < 85^{\circ}C$ unless otherwise specified

Symbol	Parameter	Min.	Typ.	Max.	Unit	Note
V_{CC}	Supply Voltage	2.7	3.0	4.0	V	
T_A	Operating Temperature	-40	25	85	$^{\circ}C$	1
I_{CC}	Supply Current		14	18	mA	
$I_{CC-PWDN}$	Power-Down Supply Current ($V_{PWD} = \text{High}$)		0.2	1.0	μA	
$f_{In(U)}$	Upper Limit of Input Frequency	5.8	6.4		GHz	2
$f_{In(L)}$	Lower Limit of Input Frequency		0.6	1.0	GHz	2
f_{Osc}	Self Oscillation Output Frequency		1.0		GHz	3
$P_{In(U)}$	Upper Limit of Input Power	0	3		dBm	
$P_{In(L)}$	Lower Limit of Input Power		-20	-10	dBm	
P_{Out}	Output Power	-15.0		0	dBm	4
V_{IH}	High-Level PWD Input Voltage	$V_{CC} - 0.2$			V	
V_{IL}	Low-Level PWD Input Voltage			0.2	V	
I_{IH}	High-Level PWD Input Current	-100.0		100.0	nA	
I_{IL}	Low-Level PWD Input Current	-100.0		100.0	nA	
PN	Residual Phase Noise at 1kHz offset from a 2.5GHz (f_{Out}) carrier		-141		dBc/Hz	

1. Sample Tested
2. For a sine-wave input.
3. Since the input signal is AC coupled, in the absence of an RF input, the prescaler may self oscillate and provide an output at this frequency. Self oscillation can be eliminated by powering down the prescaler, or applying a differential DC input voltage (a 47k resistor placed between pin 3 and V_{CC}).
4. This power is delivered to a 50 Ohm load. It excludes the power dissipated in the external pull-up resistors.

Test Circuit

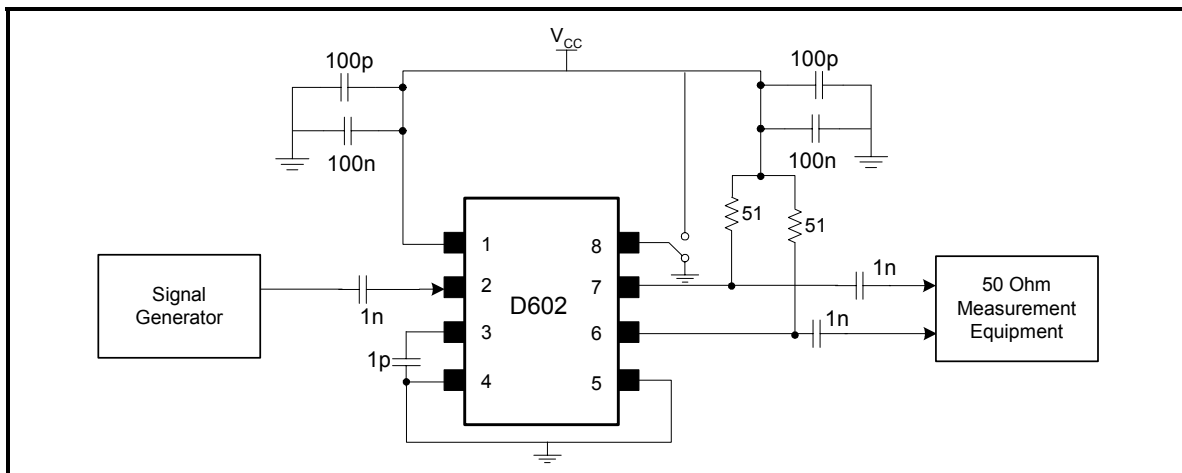

Typical Performance Characteristics

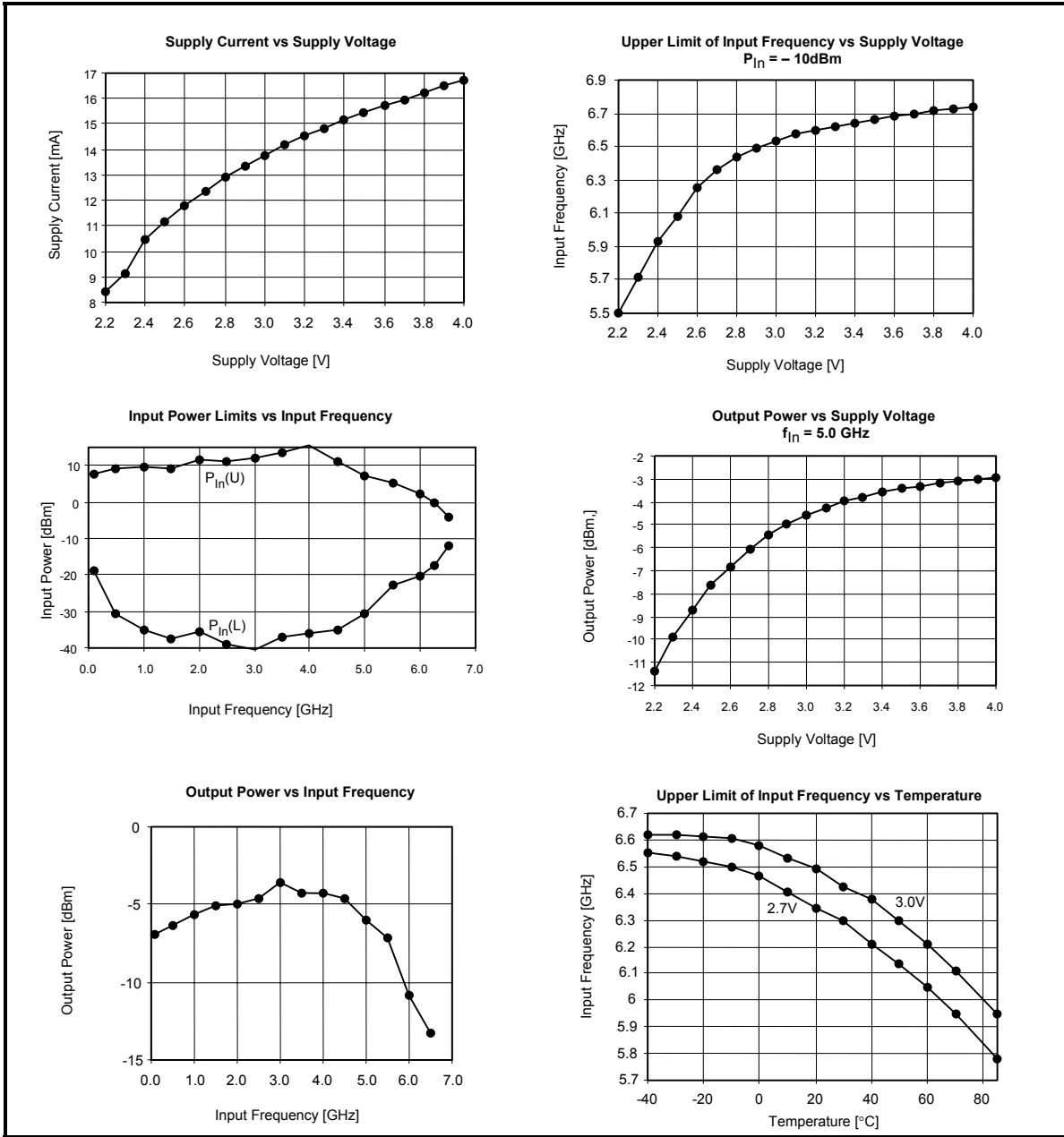

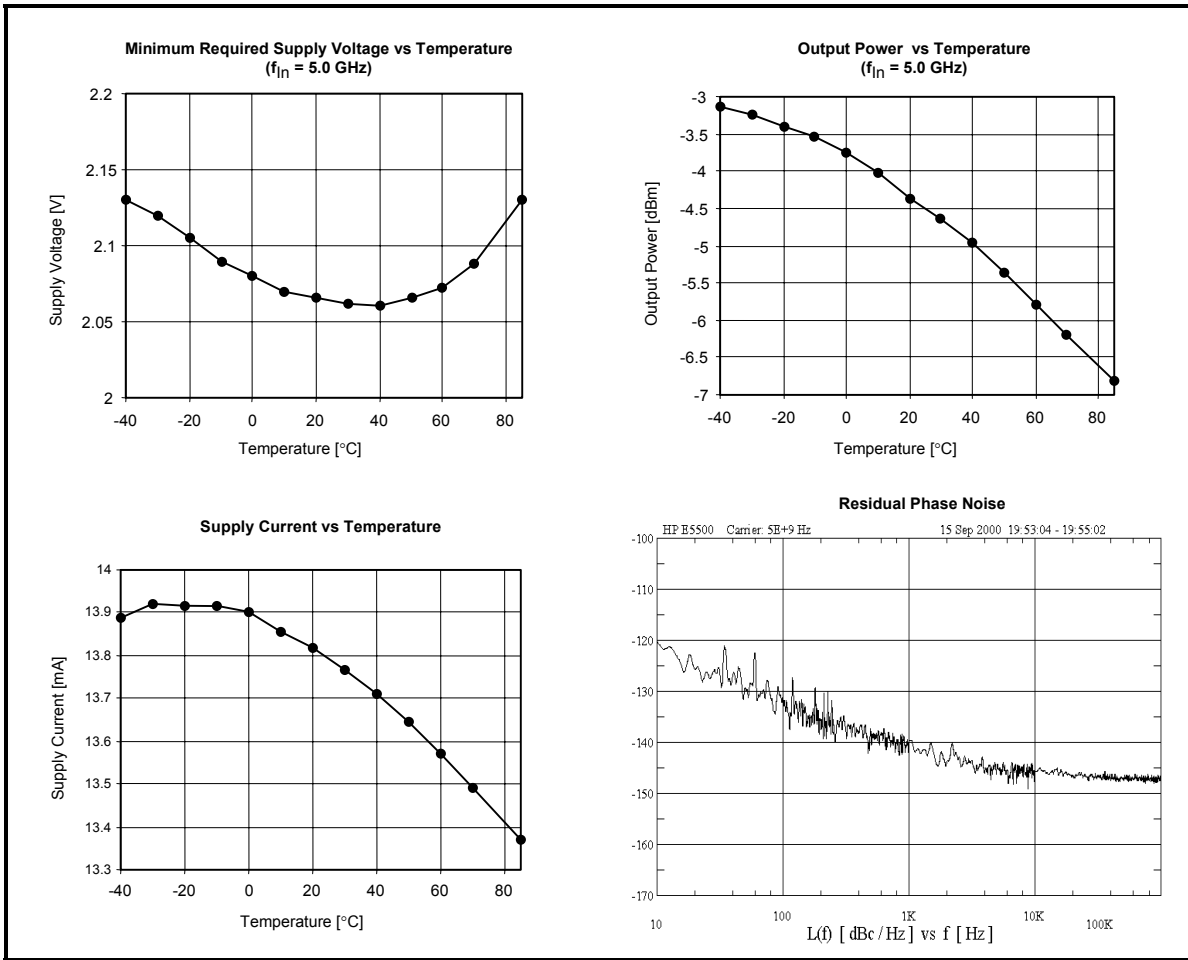

Typical Applications Information

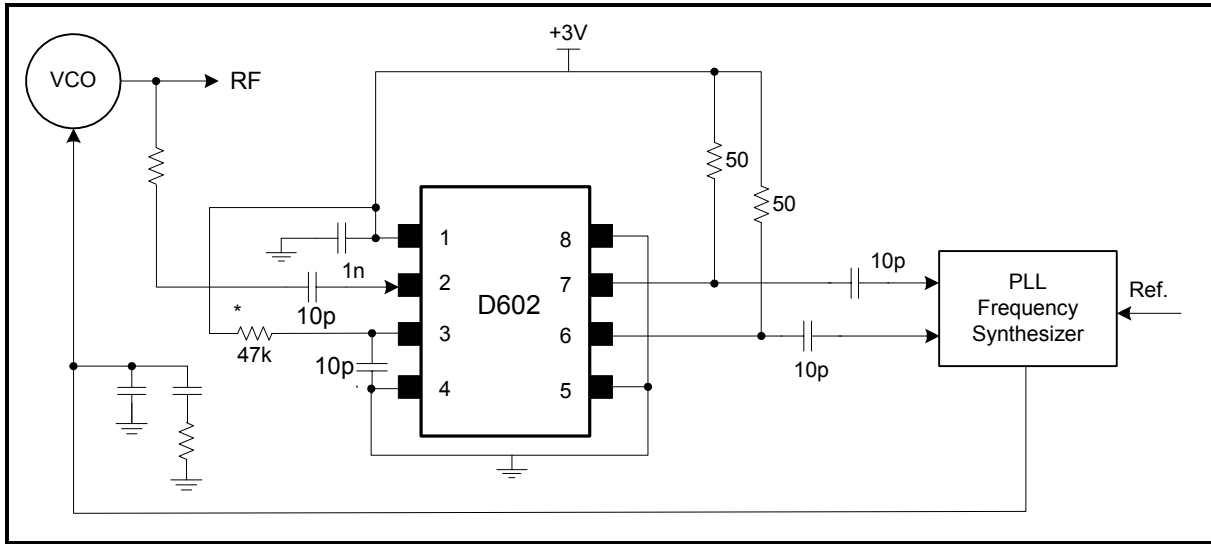

* The 47k resistor provides a DC offset that disables self oscillation in the absence of an RF input.

Cascading D602 Prescales

D602 prescalers can be cascaded to achieve division ratios other than 2. For example two D602 prescalers can be used as shown in the following diagram to perform frequency division by 4.

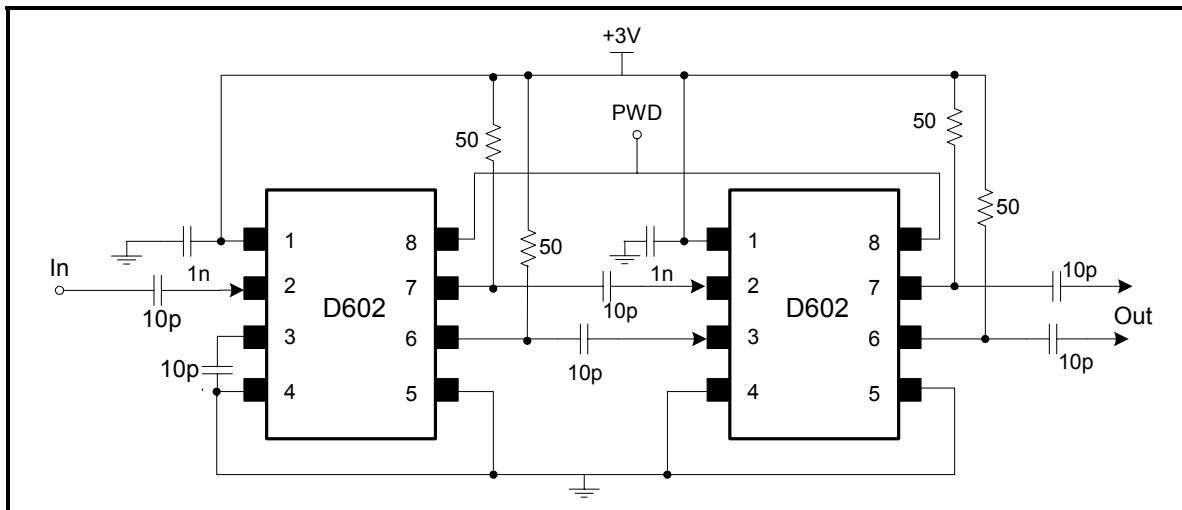

Package Description

Package dimensions in millimeters (inches)
8-Lead Plastic SOIC

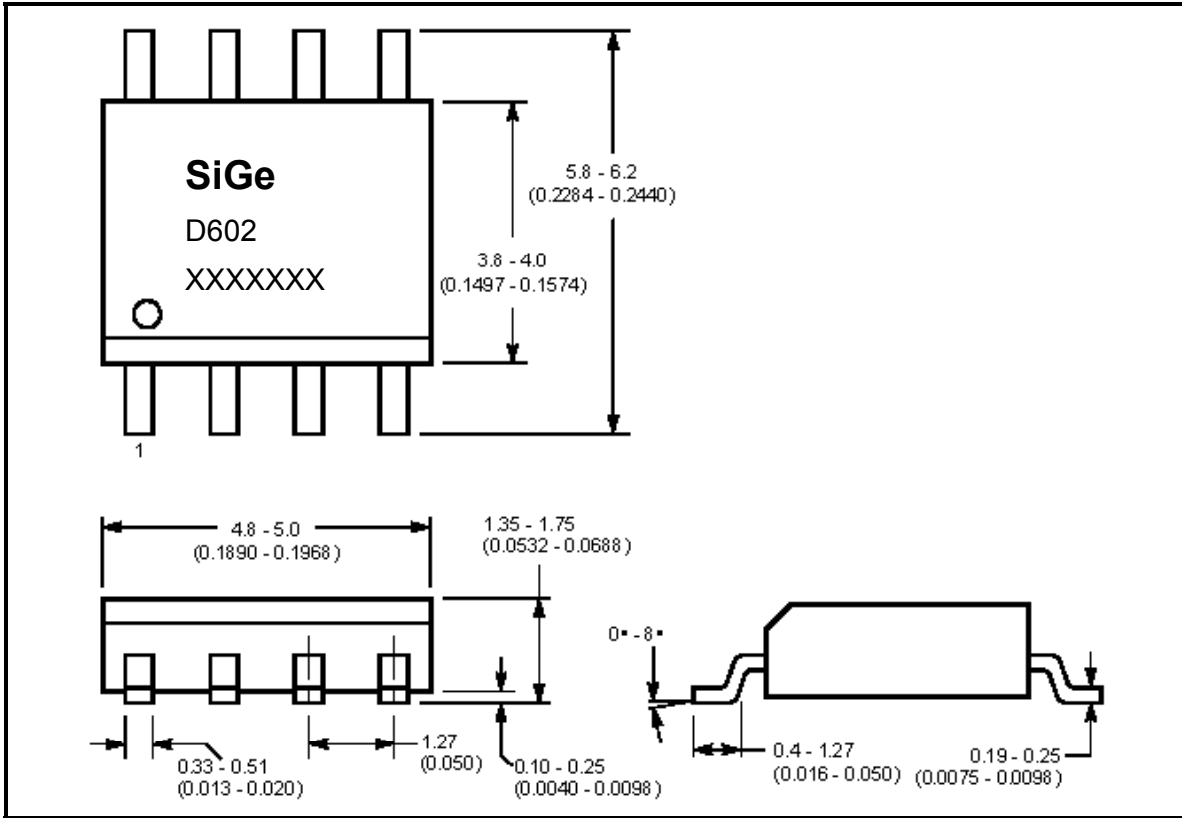

Packing Details

Note : Refer to JEDEC MS-012 for additional information

<http://www.sige.com>

Headquarters: Canada

2680 Queensview Drive

Ottawa ON K2B 8J9 Canada

Phone: +1 613 820 9244

Fax: +1 613 820 4933

sales@sige.com

U.S.A.

1150 North First Street
Suite 150
San Jose, CA 95112
U.S.A.

Phone: +1 408 998 5061

Fax: +1 408 998 5062

United Kingdom

1010 Cambourne Business Park
Cambourne
Cambridge CB3 6DP
United Kingdom

Phone: +44 (0) 1223 598444

Fax: +44 (0) 1223 598035

Information furnished is believed to be accurate and reliable and is provided on an "as is" basis. SiGe Semiconductor Inc. assumes no responsibility or liability for the direct or indirect consequences of use of such information nor for any infringement of patents or other rights of third parties which may result from its use. No license or indemnity is granted by implication or otherwise under any patent or other intellectual property rights of SiGe Semiconductor Inc. or third parties. Specifications mentioned in this publication are subject to change without notice. This publication supersedes and replaces all information previously supplied. SiGe Semiconductor Inc. products are NOT authorized for use in implantation or life support applications or systems without express written approval from SiGe Semiconductor Inc.

Copyright 2001 SiGe Microsystems
All Rights Reserved