

Transistors

# General purpose (dual digital transistors)

## UMA1N / UMB1N / FMA1A / IMB1A / IMB5A

●Feature

1) Two DTA124E chips in a UMT or SMT package.

●Absolute maximum ratings (Ta=25°C)

Parameter	Symbol	Limits	Unit
Supply voltage	V <sub>cc</sub>	-50	V
Input voltage	V <sub>in</sub>	-40	V
Output current	I <sub>o</sub>	-100	mA
Power dissipation	UMA1N, UMB1N	150(TOTAL)	mW *1
	FMA1A, IMB1A, IMB5A	300(TOTAL)	
Junction temperature	T <sub>j</sub>	150	°C
Storage temperature	T <sub>stg</sub>	-55 ~ +150	°C

\*1 120mW per element must not be exceeded.  
\*2 200mW per element must not be exceeded.

●Package, marking, and packaging specifications

Part No.	UMA1N	UMB1N	FMA1A	IMB1A	IMB5A
Package	UMT5	UMT6	SMT5	SMT6	SMT6
Marking	A1	B1	A1	B1	B5
Code	TR	TN	T148	T110	T110
Basic ordering unit (pieces)	3000	3000	3000	3000	3000

●Equivalent circuits

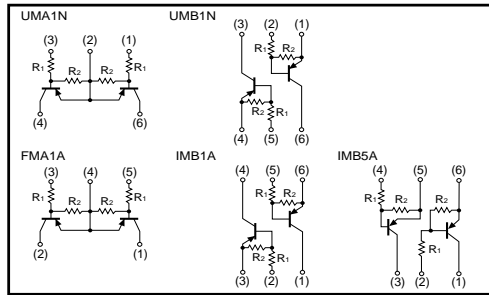

●External dimensions (Units : mm)

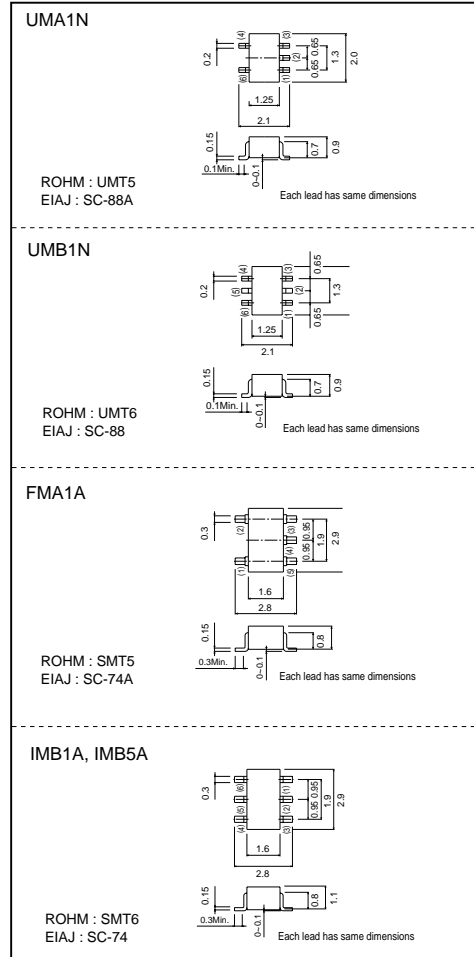

●Electrical characteristics (Ta=25°C)

Parameter	Symbol	Min.	Typ.	Max.	Unit	Conditions
Input voltage	V <sub>l(off)</sub>	-	-	-0.5	V	V <sub>cc</sub> = -5V, I <sub>o</sub> = -100μA
	V <sub>l(on)</sub>	-3	-	-	V	V <sub>o</sub> = -0.2V, I <sub>o</sub> = -5mA
Output voltage	V <sub>o(on)</sub>	-	-0.1	-0.3	V	I <sub>o/Ic</sub> = -0.5mA/-10mA
Input current	I <sub>i</sub>	-	-	-0.36	mA	V <sub>i</sub> = -5V
Output current	I <sub>o(off)</sub>	-	-	-0.5	μA	V <sub>cc</sub> = -50V, V <sub>i</sub> = 0V
DC current gain	G <sub>i</sub>	56	-	-	-	V <sub>o</sub> = -5V, I <sub>o</sub> = -5mA
Input resistance	R <sub>i</sub>	15.4	22	28.6	kΩ	-
Resistance ratio	R <sub>2</sub> /R <sub>1</sub>	0.8	1	1.2	-	-

