

ASSP For Power Supply Applications

6-ch DC/DC Converter IC

With Synchronous Rectification for voltage step-up and step-down

MB3827

■ DESCRIPTION

The MB3827 is a pulse width modulation (PWM) type 6-channel DC/DC converter IC with, synchronous rectification for voltage step-up and step-down. The MB3827 is ideal for low voltage, high efficiency, compact applications and for down conversion and up/down conversion (with two types of voltage step-up/step-down methods allowing input/output relations to be set independently).

In addition the MB3827 features a built-in self-supply power channel (channel 7) providing a wide range of supply voltages, and operates from two dry-cell batteries.

This product is ideal for high performance portable devices such as digital still cameras.

■ FEATURES

- Compatible with step-up/step-down switching methods (channel 1)
- Compatible with step-up/step-down Zeta methods (channels 2 to 6)
- Synchronous rectification (channels 1 and 2)
- Low start-up voltage : 1.8 V (channel 7 for self-power supply)
- Power supply voltage range : 4 V to 13 V (channels 1 to 6)
- Built-in high-precision reference voltage generator : 2.5 V \pm 1%
- Oscillator frequency range : 100 kHz to 800 kHz
- Error amplifier output for soft start (channels 1 to 6)

■ PACKAGE

64-pin plastic LQFP

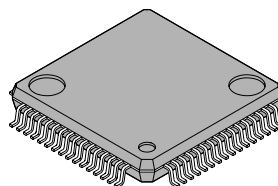

(FPT-64P-M03)

MB3827

■ PIN ASSIGNMENT

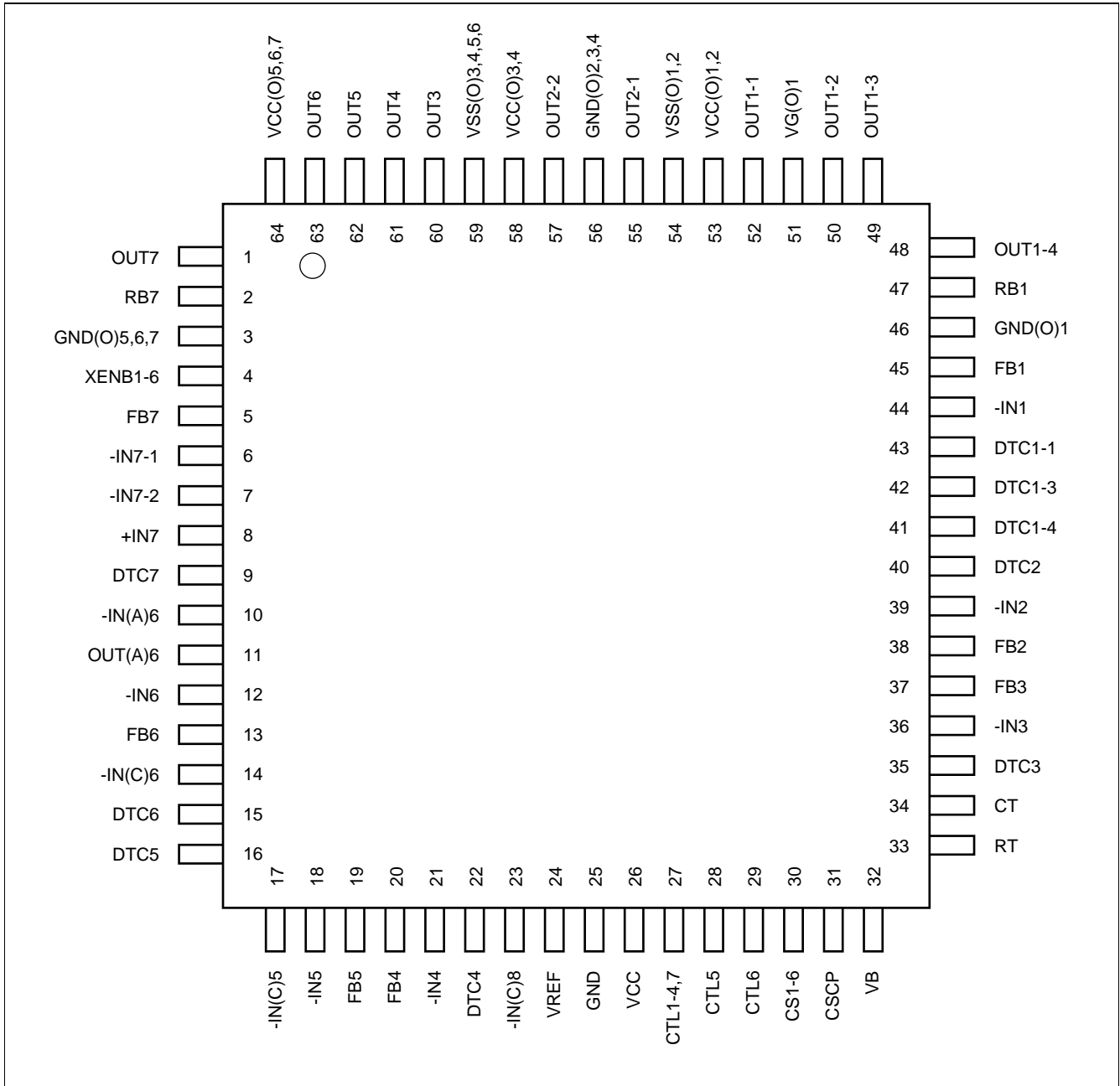

■ PIN DESCRIPTION

Pin No.	Symbol	I/O	Descriptions	
CH 1	45	FB1	O	Channel 1 error amplifier output pin.
	44	-IN1	I	Channel 1 error amplifier inverted input pin.
	43	DTC1-1	I	Channel 1 step-down main side dead time control pin.
	42	DTC1-3	I	Channel 1 step-up main side dead time control pin.
	41	DTC1-4	I	Channel 1 step-up synchronous rectifier side dead time control pin.
	52	OUT1-1	O	Channel 1 step-down main side output pin.
	50	OUT1-2	O	Channel 1 step-down synchronous rectifier side output pin.
	47	RB1	—	Channel 1 step-up main side output current setting pin.
	49	OUT1-3	O	Channel 1 step-up main side output pin.
	48	OUT1-4	O	Channel 1 step-up synchronous rectifier side output pin.
CH 2	38	FB2	O	Channel 2 error amplifier output pin.
	39	-IN2	I	Channel 2 error amplifier inverted input pin.
	40	DTC2	I	Channel 2 dead time control pin.
	55	OUT2-1	O	Channel 2 main side output pin.
	57	OUT2-2	O	Channel 2 synchronous rectifier side output pin.
CH 3	37	FB3	O	Channel 3 error amplifier output pin.
	36	-IN3	I	Channel 3 error amplifier inverted input pin.
	35	DTC3	I	Channel 3 dead time control pin.
	60	OUT3	O	Channel 3 output pin.
CH 4	20	FB4	O	Channel 4 error amplifier output pin.
	21	-IN4	I	Channel 4 error amplifier inverted input pin.
	22	DTC4	I	Channel 4 dead time control pin.
	61	OUT4	O	Channel 4 output pin.
CH 5	19	FB5	O	Channel 5 error amplifier output pin.
	18	-IN5	I	Channel 5 error amplifier inverted input pin.
	17	-IN(C)5	I	Channel 5 short detection comparator input pin.
	16	DTC5	I	Channel 5 dead time control pin.
	62	OUT5	O	Channel 5 output pin.

(Continued)

MB3827

(Continued)

Pin No.	Symbol	I/O	Descriptions	
CH 6	10	-IN(A)6	I	Channel 6 inverted amplifier input pin.
	11	OUT(A)6	O	Channel 6 inverted amplifier output pin.
	13	FB6	O	Channel 6 error amplifier output pin.
	12	-IN6	I	Channel 6 error amplifier inverted input pin.
	14	-IN4(C)6	I	Channel 6 short detection comparator input pin.
	15	DTC6	I	Channel 6 dead time control pin.
	63	OUT6	O	Channel 6 output pin.
CH 7 (for self power supply)	5	FB7	O	Channel 7 error amplifier output pin.
	6	-IN7-1	I	Channel 7 error amplifier 1 inverted input pin.
	8	+IN7	I	Channel 7 error amplifier non-inverted input pin.
	7	-IN7-2	I	Channel 7 error amplifier 2 inverted input pin.
	9	DTC7	I	Channel 7 dead time control pin.
	1	OUT7	O	Channel 7 output pin.
	2	RB7	—	Channel 7 output current setting pin.
Triangular-Wave Oscillator Circuit	33	RT	—	Triangular wave frequency setting resistor connection pin.
	34	CT	—	Triangular wave frequency setting capacitor connection pin.
Control Circuit	27	CTL1-4, 7	I	Power supply control circuit pin.(channel 1 to 4 and 7) "H" level: Power supply active mode "L" level: Standby mode
	28	CTL5	I	Channel 5 control circuit pin. When CTL1-4,7 pins = "H" level "H" level: Channel 5 in active mode "L" level: Channel 5 in standby mode
	29	CTL6	I	Channel 6 control circuit pin. When CTL1-4,7 pins = "H" level "H" level: Channel 6 in active mode "L" level: Channel 6 in standby mode
	23	-IN(C)8	I	Short detection comparator input pin.
	31	CSCP	—	Short protection circuit capacitor connection pin.
	30	CS1-6	—	Soft start circuit capacitor connection pin (channel 1 to 6).
	4	XENB1-6	I	VREF control pin (channel 1 to 6 output control pin). When CTL1-4, 7 pin = "H" "H" level: VREF "L" level, channel 1 to 6 output "OFF" "L" level: VREF "H" level, channel 1 to 6 output "active"

(Continued)

(Continued)

Pin No.	Symbol	I/O	Description	
Power Supply Circuit	26	VCC	—	Reference voltage and control circuit power supply pin.
	53	VCC(O)1,2	—	Output circuit power supply pin (Channel 1, 2).
	58	VCC(O)3,4	—	Output circuit power supply pin (Channel 3, 4).
	64	VCC(O)5,6,7	—	Output circuit power supply pin (Channel 5, 6, 7).
	54	VSS(O)1,2	—	Main side output circuit power supply pin (Channel 1, 2).
	51	VG(O)1	—	Step-up synchronous rectifier side output circuit power supply pin (Channel 1).
	59	VSS(O)3,4,5,6	—	Output circuit power supply pin (Channel 3, 4, 5, 6).
	24	VREF	O	Reference voltage output pin.
	32	VB	O	Triangular wave oscillator regulator output pin.
	25	GND	—	Ground pin.
	46	GND(O)1	—	Output circuit ground pin (Channel 1).
	56	GND(O)2,3,4	—	Output circuit ground pin (Channel 2, 3, 4).
	3	GND(O)5,6,7	—	Output circuit ground pin (Channel 5, 6, 7).

MB3827

■ BLOCK DIAGRAM

- General view

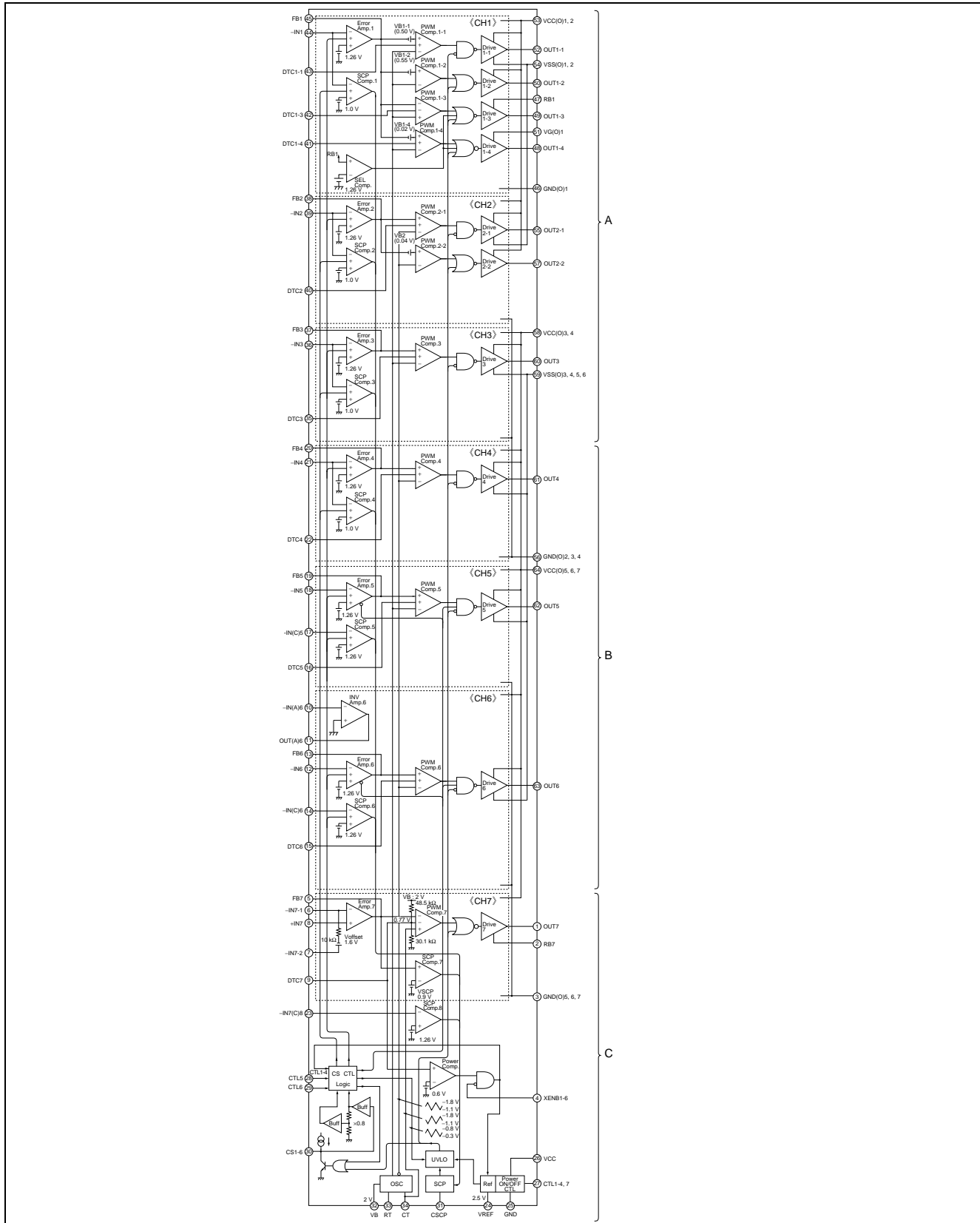

• Enlarged view of A

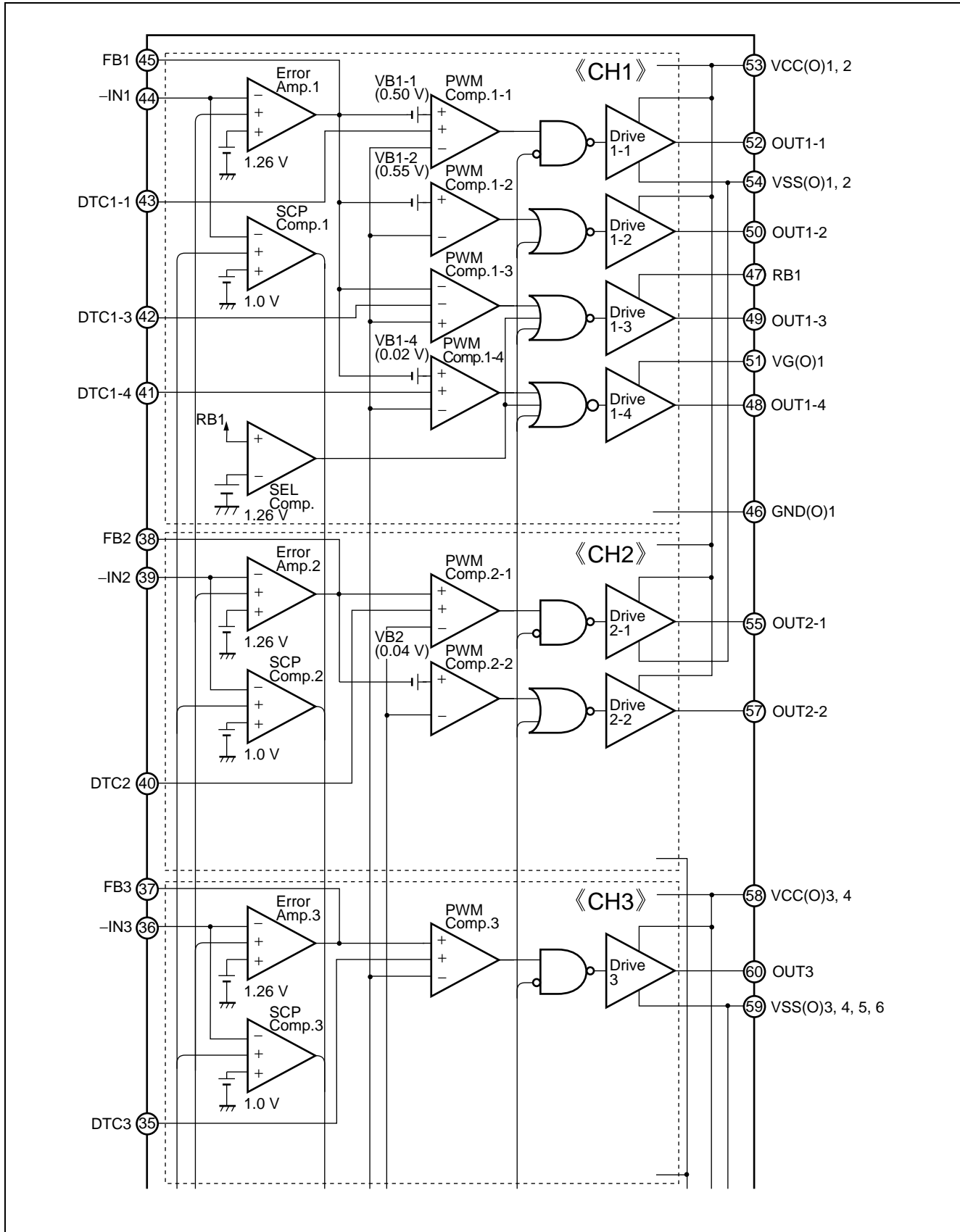

MB3827

• Enlarged view of B

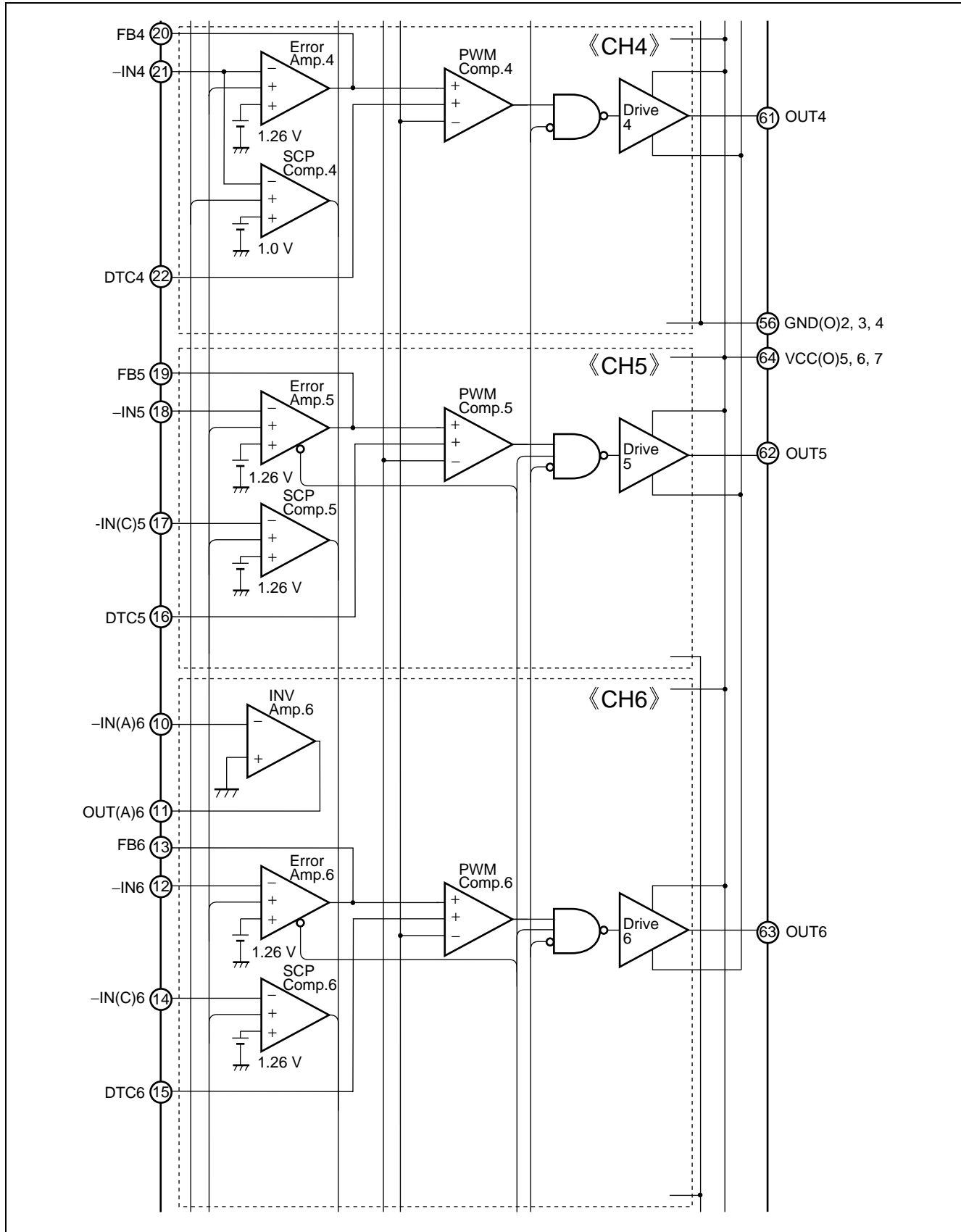

• Enlarged view of C

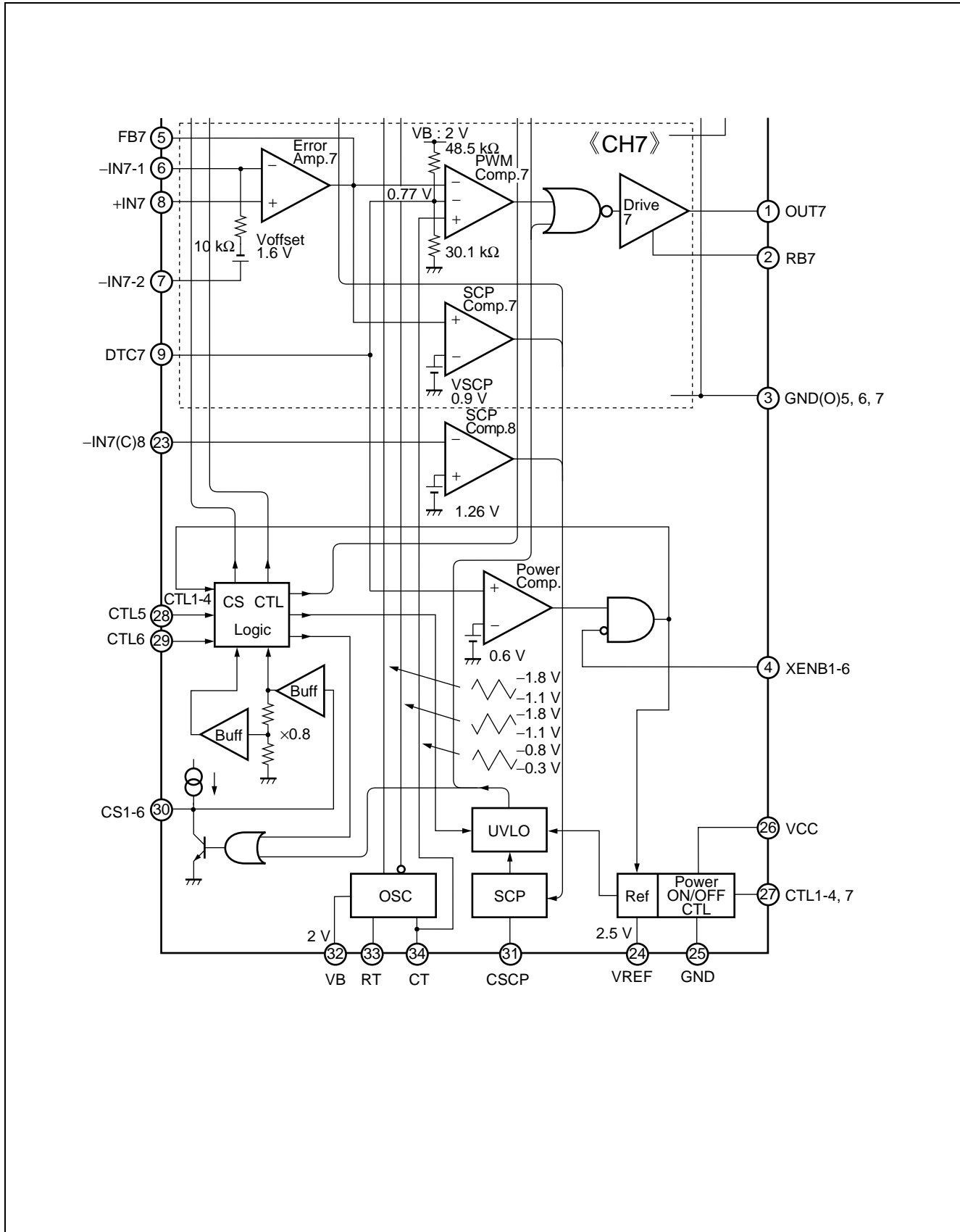

■ ABSOLUTE MAXIMUM RATINGS

Parameter	Symbol	Conditions	Rating		Unit
			Min.	Max.	
Power supply voltage	V _{CC}	—	—	17	V
	V _E	—	—	17	V
Output current	I _O	OUT pin	—	20	mA
Peak output current	I _O	OUT pin, Duty ≤ 5%	—	200	mA
Power dissipation	P _D	T _a ≤ +25°C	—	1000*	mW
Storage temperature	T _{stg}	—	-55	+125	°C

* : The packages are mounted on the dual-sided epoxy board (10 cm × 10 cm).

WARNING: Semiconductor devices can be permanently damaged by application of stress (voltage, current, temperature, etc.) in excess of absolute maximum ratings. Do not exceed these ratings.

■ RECOMMENDED OPERATING CONDITIONS

Parameter	Symbol	Conditions	Value			Unit
			Min.	Typ.	Max.	
Power supply voltage	V _{CC}	Channel 7	1.8	9	13	V
		Channel 1 to 6	4	9	13	V
Reference voltage output current	I _{OR}	—	-1	—	0	mA
Input voltage	V _{IN}	+IN, -IN, -IN(C) pin	0	—	V _{CC} - 1.8	V
Control input voltage	V _{CTL}	CTL pin	0	—	13	V
Output current	I _O	OUT pin	1	2	15	mA
Output current setting resistor	R _B	RB pin	2.2	24	51	kΩ
Triangular wave oscillator frequency	f _{OSC}	—	100	500	800	kHz
Timing capacitor	C _T	—	47	100	1000	pF
Timing resistor	R _T	—	13	18	47	kΩ
Soft-start capacitor	C _S	—	—	0.1	1.0	μF
	C _{DTC}	DTC7 pin	—	1	10	μF
Short detection capacitor	C _{SCP}	—	—	0.1	1.0	μF
Operating ambient temperature	T _a	—	-30	+25	+85	°C

WARNING: The recommended operating conditions are required in order to ensure the normal operation of the semiconductor device. All of the device's electrical characteristics are warranted when the device is operated within these ranges.

Always use semiconductor devices within their recommended operating condition ranges. Operation outside these ranges may adversely affect reliability and could result in device failure.

No warranty is made with respect to uses, operating conditions, or combinations not represented on the data sheet. Users considering application outside the listed conditions are advised to contact their FUJITSU representatives beforehand.

■ ELECTRICAL CHARACTERISTICS

(Ta = +25°C, V_{CC} = 9 V, V_{SS} = 4.4 V, V_G = 11 V)

Parameter	Symbol	Pin No.	Conditions	Value			Unit	
				Min.	Typ.	Max.		
Reference voltage block (Ref)	Output voltage	V _{REF}	24	—	2.475	2.5	2.525	V
	Output voltage temperature stability	$\frac{\Delta V_{REF}}{V_{REF}}$	24	Ta = -30°C to +85°C	—	0.5*	—	%
	Input stability	Line	24	V _{CC} = 4 V to 13 V	-10	—	10	mV
	Load stability	Load	24	V _{REF} = 0 mA to -1 mA	-10	—	10	mV
	Short-circuit output current	I _{OS}	24	V _{REF} = 2 V	-20	-5	-1	mA
Under voltage lockout protection circuit block (CH1 to 6) (UVLO)	Threshold voltage	V _{TH}	52	V _{CC} = $\sqrt{\quad}$	2.6	2.8	3.0	V
	Hysteresis width	V _H	52	—	—	0.2	—	V
	Reset voltage	V _{RST}	52	—	1.35	1.50	1.65	V
Under voltage lockout protection circuit block (CH7) (UVLO)	Threshold voltage	V _{TH}	1	V _{CC} = $\sqrt{\quad}$	1.3	1.5	1.7	V
Soft-start block (CS)	Input standby voltage	V _{STB}	30	—	—	50	100	mV
	Charge current	I _{CS}	30	—	-1.4	-1.0	-0.6	μA
Short circuit detection block (SCP)	Threshold voltage	V _{TH}	31	—	0.63	0.68	0.73	V
	Input standby voltage	V _{STB}	31	—	—	50	100	mV
	Input latch voltage	V _I	31	—	—	50	100	mV
	Input source current	I _{CSCP}	31	—	-1.4	-1.0	-0.6	μA
Triangular waveform oscillator block (OSC)	Oscillator frequency	f _{OSC}	52,50,49,48,55,57,60,61,62,63	C _T = 100 pF, R _T = 18 kΩ	450	500	550	kHz
	Frequency voltage stability	$\Delta f/f_{dv}$	52,50,49,48,55,57,60,61,62,63	V _{CC} = 4 V to 13 V	—	1	10	%
	Frequency temperature stability	$\Delta f/f_{dT}$	52,50,49,48,55,57,60,61,62,63	Ta = -30°C to +85°C	—	1*	—	%

*: Standard design value.

(Continued)

MB3827

(Continued)

($T_a = +25^\circ\text{C}$, $V_{CC} = 9\text{ V}$, $V_{SS} = 4.4\text{ V}$, $V_G = 11\text{ V}$)

Parameter	Symbol	Pin No	Conditions	Value			Unit	
				Min.	Typ.	Max.		
Error amplifier block (CH1 to CH6)	Threshold voltage	V_{TH}	45,38,37, 20,19,13	FB = 1.0 V	1.45	1.50	1.55	V
	V_T temperature stability	$\frac{\Delta V_T}{V_T}$	45,38,37, 20,19,13	$T_a = -30^\circ\text{C}$ to $+85^\circ\text{C}$	—	0.5*	—	%
	Input bias current	I_B	45,39,36,2 1	-IN = 0 V (CH1 to 4)	-320	-80	—	nA
			18,12	-IN = 0 V (CH5,6)	-120	-30	—	nA
	Voltage gain	A_V	45,38,37, 20,19,13	DC	60	100	—	dB
	Frequency bandwidth	B_W	45,38,37, 20,19,13	$A_V = 0\text{ dB}$	—	1.0*	—	MHz
	Output voltage	V_{OH}	45,38,37, 20,19,13	—	2.2	2.4	—	V
		V_{OL}	45,38,37, 20,19,13	—	—	20	200	mV
	Output source current	I_{SOURCE}	45,38,37, 20,19,13	FB = 1.35 V	—	-2.0	-1.0	mA
	Output sink current	I_{SINK}	45,38,37, 20,19,13	FB = 1.35 V (CH1)	50	100	—	μA
FB = 1.35 V (CH2)				65	130	—	μA	
FB = 1.35 V (CH3 to 6)				75	150	—	μA	
Error amplifier block (CH7)	Input offset voltage	V_{IO}	6	-IN2 = 0V, FB = 0.55V	—	—	20	mV
			7	+IN = 0 V	1.45	1.55	1.65	V
	V_T temperature stability	$\frac{\Delta V_T}{V_T}$	5	$T_a = -30^\circ\text{C}$ to $+85^\circ\text{C}$	—	0.5*	—	%
	Input bias current	I_B	7	-IN2 = V_{CC}	—	15	30	μA
			8	+IN = 0 V	-100	-20	—	nA
	Common mode input voltage range	V_{CM}	5	—	0	—	$V_{CC} - 0.9$	V
	Voltage gain	A_V	5	DC	60	75	—	dB
	Frequency bandwidth	B_W	5	$A_V = 0\text{ dB}$	—	1.0*	—	MHz
	Output voltage	V_{OH}	5	—	1.1	1.3	—	V
		V_{OL}	5	—	—	20	200	mV
Output source current	I_{SOURCE}	5	FB = 0.55 V	—	-2.0	-1.0	mA	
Output sink current	I_{SINK}	5	FB = 0.55 V	65	130	—	μA	

*: Standard design value.

(Continued)

(Continued)

($T_a = +25^\circ\text{C}$, $V_{CC} = 9\text{ V}$, $V_{SS} = 4.4\text{ V}$, $V_G = 11\text{ V}$)

Parameter	Symbol	Pin No.	Conditions	Value			Unit	
				Min.	Typ.	Max.		
Inverse amplifier block (CH6) (INV Amp.)	Threshold voltage	V_{TH}	11	—	-10	0	10	mV
	Input bias current	I_B	10	$-IN = -0.1\text{ V}$	-120	-30	—	nA
	Voltage gain	A_V	11	DC	60	100	—	dB
	Frequency bandwidth	BW	11	$A_V = 0\text{ dB}$	—	1.0*	—	MHz
	Output voltage	V_{OH}	11	—	2.2	2.4	—	V
		V_{OL}	11	—	—	20	100	mV
	Output source current	I_{SOURCE}	11	OUT = 1.26 V	—	-2.0	-1.0	mA
Output sink current	I_{SINK}	11	OUT = 1.26 V	75	150	—	μA	
Short detection comparator block (CH1-4) (SCP Comp.)	Threshold voltage	V_{TH}	52,50,49, 48,55,57, 60,61	—	0.97	1.00	1.03	V
	Input bias current	I_B	44,39,36, 21	$-IN = 0\text{ V}$	-320	-80	—	nA
Short detection comparator block (CH5,6) (SCP Comp.)	Input offset voltage	V_{IO}	62,63	—	1.22	1.26	1.30	V
	Input bias current	I_B	17,14,23	$-IN(C) = 0\text{ V}$	-200	-50	—	nA
Short detection comparator block (CH7) (SCP Comp.)	Threshold voltage	V_{TH}	1	—	0.8	0.9	1.0	V
PWM comparator block (CH1) (PWM Comp.-1)	Threshold voltage	V_{T0}	52	Duty cycle = 0 %	0.5	0.6	—	V
		V_{T100}	52	Duty cycle = 100 %	—	1.3	1.4	V

*: Standard design value.

(Continued)

MB3827

(Continued)

($T_a = +25^\circ\text{C}$, $V_{CC} = 9\text{ V}$, $V_{SS} = 4.4\text{ V}$, $V_G = 11\text{ V}$)

Parameter		Symbol	Pin No.	Conditions	Value			Unit
					Min.	Typ.	Max.	
PWM comparator block (CH1) (PWM Comp.-2)	Threshold voltage	V_{T100}	50	Duty cycle = 100 %	0.450	0.550	—	V
		V_{T0}	50	Duty cycle = 0 %	—	1.250	1.350	V
PWM comparator block (CH1) (PWM Comp.-3)	Threshold voltage	V_{T0}	49	Duty cycle = 0 %	1.0	1.1	—	V
		V_{T100}	49	Duty cycle = 100 %	—	1.8	1.9	V
PWM comparator block (CH1) (PWM Comp.-4)	Threshold voltage	V_{T100}	48	Duty cycle = 100 %	0.980	1.080	—	V
		V_{T0}	48	Duty cycle = 0 %	—	1.780	1.880	V
PWM comparator block (CH2) (PWM Comp.-1)	Threshold voltage	V_{T0}	55	Duty cycle = 0 %	1.0	1.1	—	V
		V_{T100}	55	Duty cycle = 100 %	—	1.8	1.9	V
PWM comparator block (CH2) (PWM Comp.-2)	Threshold voltage	V_{T100}	57	Duty cycle = 100 %	0.960	1.060	—	V
		V_{T0}	57	Duty cycle = 0 %	—	1.760	1.860	V
PWM comparator block (CH3 to 6) (PWM Comp.)	Threshold voltage	V_{T0}	60,61,62,63	Duty cycle = 0 %	1.0	1.1	—	V
		V_{T100}	60,61,62,63	Duty cycle = 100 %	—	1.8	1.9	V

*: Standard design value.

(Continued)

(Continued)

($T_a = +25^\circ\text{C}$, $V_{CC} = 9\text{ V}$, $V_{SS} = 4.4\text{ V}$, $V_G = 11\text{ V}$)

Parameter		Symbol	Pin No.	Conditions	Value			Unit
					Min.	Typ.	Max.	
PWM comparator block (CH7) (PWM Comp.)	Threshold voltage	V_{T0}	1	Duty cycle = 0 %	0.2	0.3	—	V
		V_{Tmax}	1	—	—	0.77	0.87	V
	Maximum duty cycle	Dtr	1	$C_T=100\text{pF}, R_T=18\text{k}\Omega, R_B=24\text{k}\Omega, R_L=390\text{k}\Omega$	70	80	90	%
Dead time control block (CH1-6) (PWM Comp.)	Threshold voltage	V_{TD0}	52,49,48,55,60,61,62,63	Duty cycle = 0 %	1.0	1.1	—	V
		V_{TD100}	52,49,48,55,60,61,62,63	Duty cycle = 100 %	—	1.8	1.9	V
	Input current	I_{DTC}	43,42,41,40,35,22,16,15	DTC = 0.4 V	-1.0	-0.3	—	μA
Dead time control block (CH7) (PWM Comp.)	Threshold voltage	V_{TD0}	1	Duty cycle = 0 %	0.2	0.3	—	V
		V_{TD100}	1	Duty cycle = 100 %	—	0.8	0.9	V
Output block (CH1-6) (Drive-1)	Output source current	I_{SOURCE}	52,55,60,61,62,63	Duty \leq 5 %, OUT= 4.4V	—	-90	—	mA
	Output sink current	I_{SINK}	52,55,60,61,62,63	Duty \leq 5 %, OUT= 9V	—	80	—	mA
	Output voltage	V_{OH}	52,55,60,61,62,63	$I_o = -15\text{ mA}$	3.5	4.0	—	V
		V_{OL}	52,55,60,61,62,63	$I_o = 15\text{ mA}$	—	100	300	mV
Output block (CH1,2) (Drive-2)	Output source current	I_{SOURCE}	50,57	Duty \leq 5 %, OUT= 0V	—	-100	—	mA
	Output sink current	I_{SINK}	50,57	Duty \leq 5 %, OUT= 4V	—	80	—	mA
	Output voltage	V_{OH}	50,57	$I_o = -15\text{ mA}$	3.5	4.0	—	V
		V_{OL}	50,57	$I_o = 15\text{ mA}$	—	100	300	mV
Output block (CH1) (Drive-3)	Output source current	I_{SOURCE}	49	$R_B = 24\text{k}\Omega$, OUT= 0.7V	-2.6	-2.0	-1.4	mA
	Output sink current	I_{SINK}	49	Duty \leq 5 %, OUT= 0.7V	—	40	—	mA

*: Standard design value.

(Continued)

MB3827

(Continued)

($T_a = +25^\circ\text{C}$, $V_{CC} = 9\text{ V}$, $V_{SS} = 4.4\text{ V}$, $V_G = 11\text{ V}$)

Parameter	Symbol	Pin No.	Conditions	Value			Unit	
				Min.	Typ.	Max.		
Output block (CH1) (Drive-4)	Output source current	I _{SOURCE}	48	Duty ≤ 5 %, OUT= 5V	—	-100	—	mA
	Output sink current	I _{SINK}	48	Duty ≤ 5 %, OUT= 2V	—	120	—	mA
	Output voltage	V _{OH}	48	I _o = -15 mA	9.7	10	—	V
		V _{OL}	48	I _o = 15 mA	—	1.0	1.3	V
Output block (CH7) (Drive)	Output source current	I _{SOURCE}	1	R _B = 24kΩ, OUT= 0.7V	-2.6	-2.0	-1.4	mA
	Output sink current	I _{SINK}	1	Duty ≤ 5 %, OUT= 0.7V	—	40	—	mA
Control block (CTL1 to 4, XENB1 to 6) (CTL, XENB)	CTL input condition	V _{IH}	27,4	Active mode	1.5	—	13	V
		V _{IL}	27,4	Standby mode	0	—	0.5	V
	Input current	I _{CTL}	27,4	CTL=5V, XENB=5V	—	100	200	μA
Control block (CTL5,6) (CTL)	CTL input condition	V _{IH}	28,9	Active mode	2.1	—	13	V
		V _{IL}	28,9	Standby mode	0	—	0.7	V
	Input current	I _{CTL}	28,9	CTL= 5V	—	50	100	μA
General	Standby current	I _{CCS}	26	CTL1-4,7= 0V	—	—	10	μA
		I _{CCS(O)}	53,58,64	CTL1-4,7= 0V	—	—	10	μA
		I _G	51	CTL1-4,7= 0V	—	—	10	μA
	Power supply current	I _{CC}	26,53,58, 64	CTL1-4,7= CTL5 =CTL6=5V	—	8	12	mA

* Standard design value.

TYPICAL CHARACTERISTICS

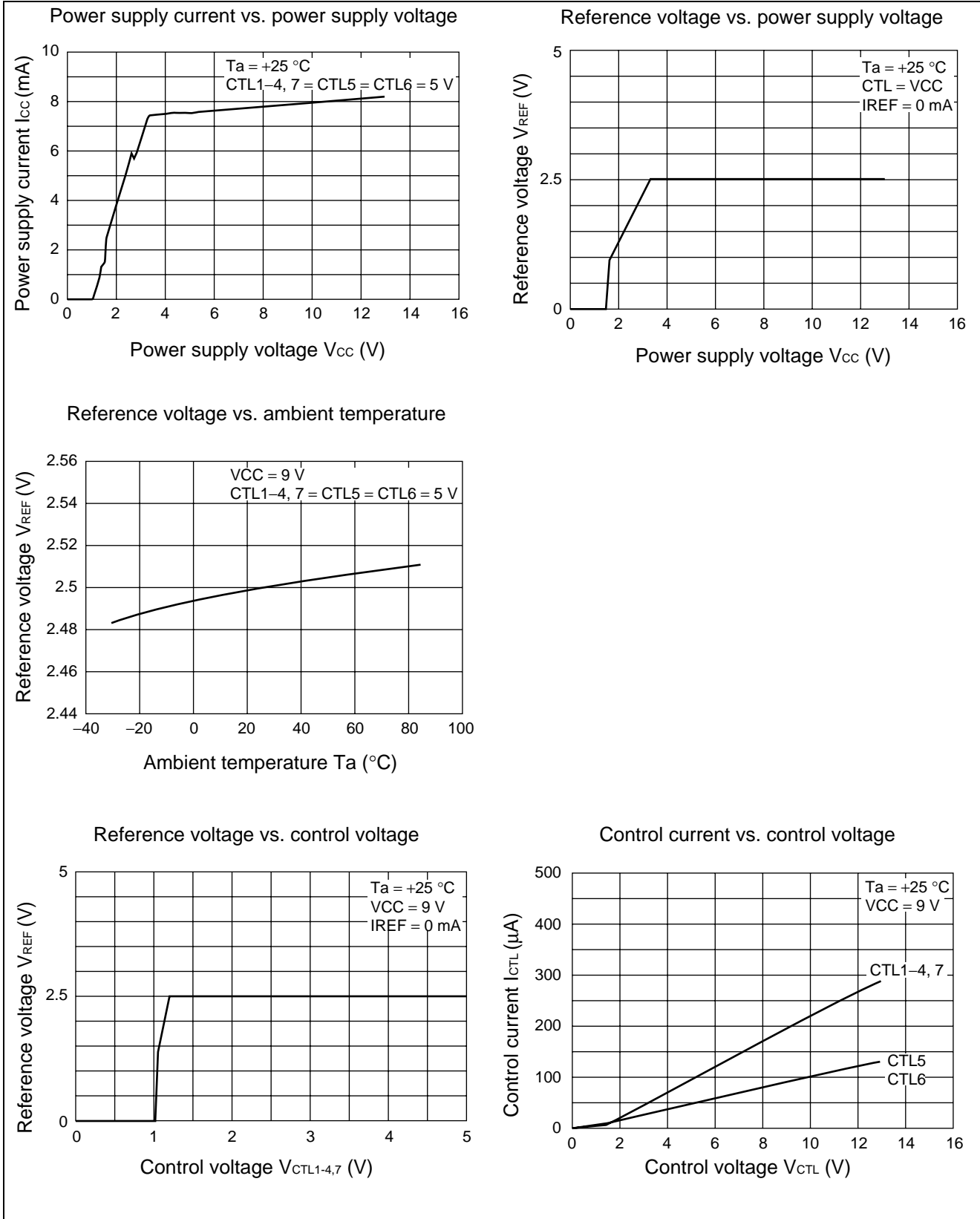

(Continued)

(Continued)

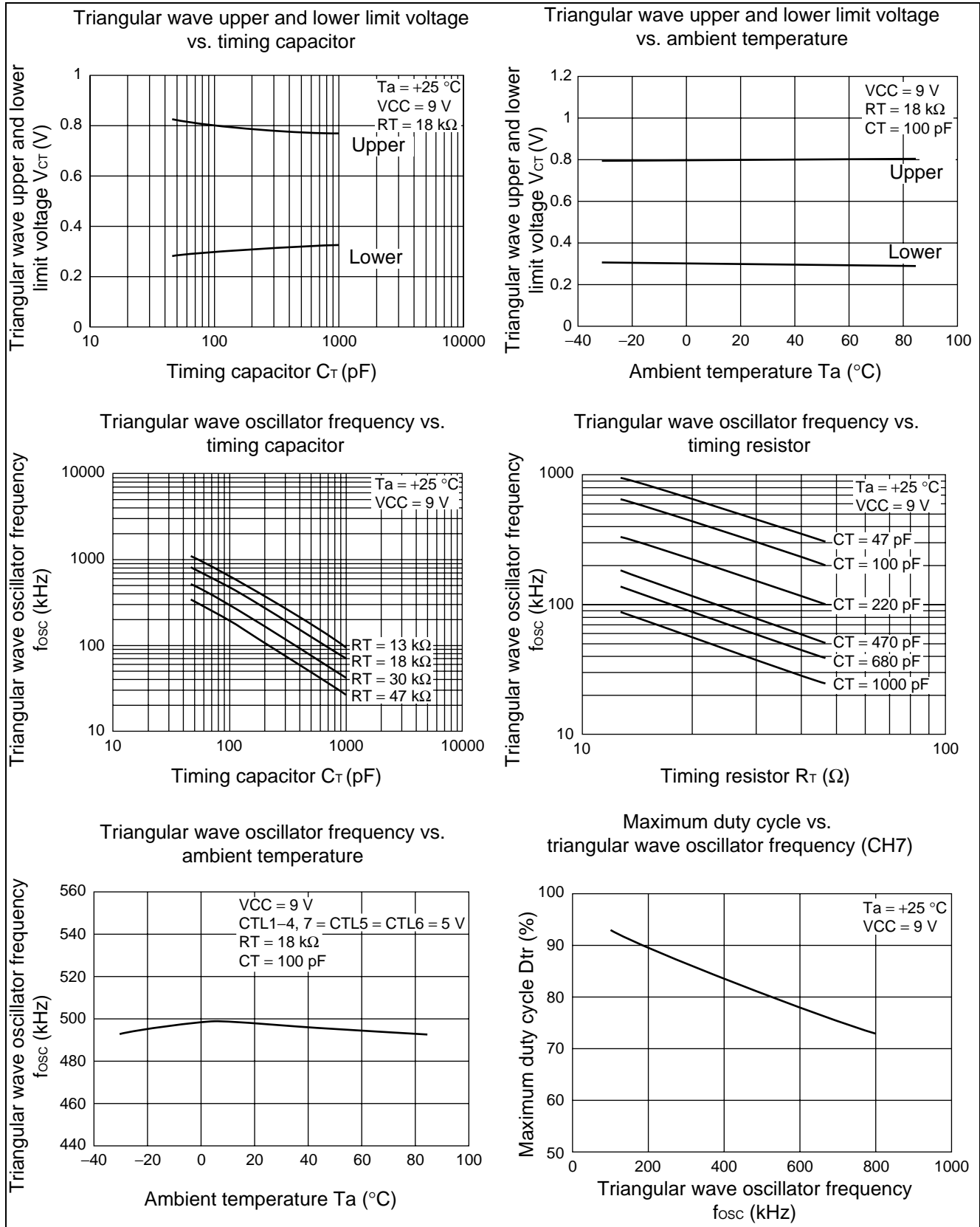

(Continued)

(Continued)

Error amplifier gain and phase vs. frequency (CH1)

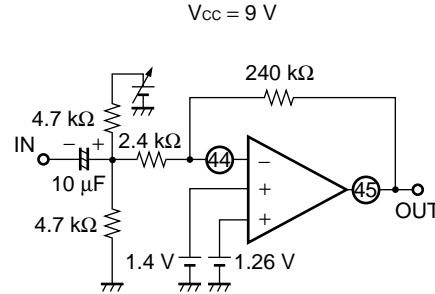
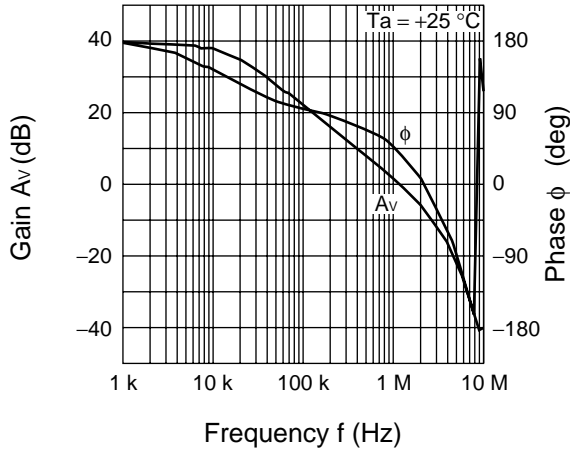

Error amplifier gain and phase vs. frequency (CH7)

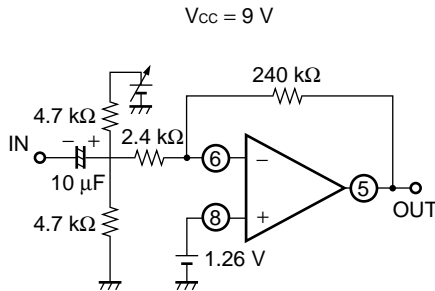
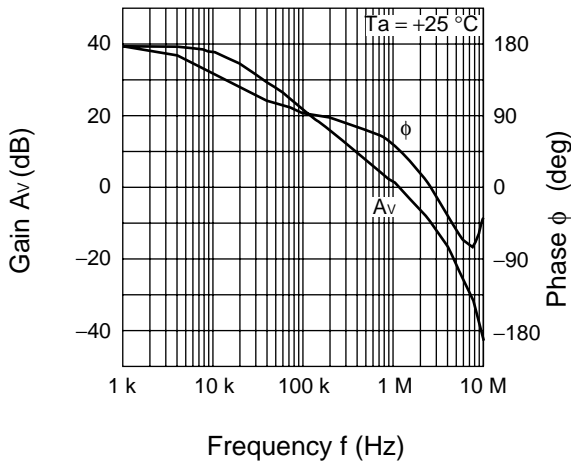

Power dissipation vs. ambient temperature

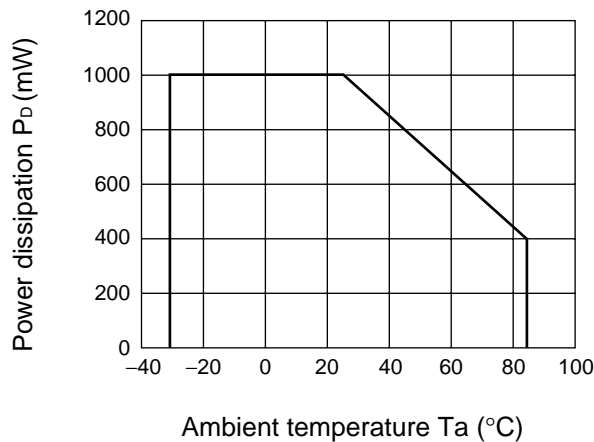

■ FUNCTIONAL DESCRIPTION

1. Switching Regulator Function

(1) Reference voltage circuit

The reference voltage circuit generates a temperature-compensated reference voltage (≈ 2.50 V) using the voltage supplied from the power supply terminal (pin 26). This voltage is used as the reference voltage for the internal circuits of the IC. The reference voltage of up to 1mA can also be supplied to an external device from the VREF terminal (pin 24).

(2) Triangular-wave oscillator circuit

By connecting a timing capacitor and a resistor to the CT (pin 34) and the RT (pin 33) terminals, it is possible to generate any desired triangular oscillation waveform (CT : amplitude 0.3V to 0.8V, CT1 : amplitude 1.1V to 1.8V in phase with CT, and CT2 : amplitude 1.1V to 1.8V in inverse phase with CT). The triangular wave is input to CT1, CT2 and the PWM comparator within the IC.

(3) Error amplifier (Error Amp.)

The error amp. is an amplifier circuit that detects the output voltage from the switching regulator and produces the PWM control signal. The broad in-phase input voltage range of 0 V to $V_{cc} - 1.8$ V (1-6 ch) and 0 V to $V_{cc} - 0.9$ V (channel 7) provides easy setting from external power supplies.

Also, it is possible to provide stable phase compensation for a system by setting up any desired level of loop gain, by connecting feedback resistance and a capacitor between the error amp. output pin and the inverse input pin.

(4) Inverter amplifier (Inv. Amp.)

The inverter amplifier detects the output voltage (negative voltage) from the switching regulator, and outputs a control signal to the error amplifier.

(5) PWM comparator (PWM Comp.)

The voltage-pulse width modulator controls the output duty according to the input voltage.

(Channel 1 to 2, main side, and channel 3 to 7)

During the interval that the error amplifier output voltage and DTC are higher than the triangular wave, the output transistor is turned on.

(Channel 1 step-down synchronous rectifier side)

During the interval when the error amplifier output voltage is lower than the triangular wave, the output transistor is turned on.

(Channel 1 step-up synchronous rectifier side)

During the interval when the error amplifier output voltage and DTC3 voltage are lower than the triangular wave, the output transistor is turned on.

(6) Output circuit

The output circuits is comprised of a totem-pole configuration on both the main side and synchronous rectifier side, and can drive an external PNP transistor (main side) or NPN transistor (channel 1 step-up main side, channel 7) or N-ch MOSFET (synchronous rectifier side).

2. Channel Control Function

Channel on and off levels are dependent on the voltage levels of the CTL1-4,7 terminal (pin 27), XENB1-6 terminal (pin 4), CTL5 terminal (pin 28), and CTL6 terminal (pin 29).

Each Channel On/Off Setting Conditions.

Voltage level of CTL pin				Channel on/off setting conditions				
CTL1-4,7	XENB1-6	CTL5	CTL6	Power	CH7	CH1 to 4	CH5	CH6
L	X	X	X	OFF (standby state)				
H	H	X	X	ON	ON	OFF	ON	OFF
	L	L	L			ON		ON
			H			ON	ON	
		H	L			OFF	OFF	
			H			OFF	ON	

Note: When the RB1 pin is connected to the V_{REF} pin, the OUT1-3 and OUT1-4 pins are held at “L” level.

X : Don't care.

3. Protective Functions

(1) Timer-latch short protection circuit

The short detection comparator in each channel detects the output voltage level, and when any channel output voltage falls below the short detection voltage, or the –IN(C)8 terminal (pin 23) voltage falls below the reference voltage, the timer circuit starts operating and the capacitor C_{SCP} connected to the CSCP terminal (pin 31) starts charging.

When the capacitor voltage reaches approximately 0.68 V, the output transistor is turned off and the dead time becomes 100%.

When actuated, this protection circuit can be reset by turning on the power supply again. (See “METHOD OF SETTING TIME CONSTANT FOR TIMER-LATCH SHORT PROTECTION CIRCUIT”.)

(2) Under voltage lockout protection circuit

A transient state at power-on or a momentary drop of the power supply voltage causes the control IC to malfunction, resulting in system breakdown or system deterioration. Malfunction like the above-mentioned will be prevented, by detecting the internal reference voltage with respect to the power supply voltage, this protection circuit resets the latch circuit to turn off the output transistor and set the duty (OFF) = 100 %, while at the same time holding the CSCP terminal (pin 31) at the “L”. The reset is cleared when the power supply voltage becomes greater than or equal to the threshold voltage level of this protection circuit.

4. Soft Start Operation

(1) Operating Description

- Simultaneous "H" level of CTL1-4, 7 terminal, and CTL5 terminal, CTL6 terminal

When CTL1-4, 7 terminal (pin 27), and CTL5 terminal (pin 28), CTL6 terminal (pin 29) are started at the same time, the capacitor (C_{DTC}) connected to DTC7 terminal (pin 9) starts charging. When the DTC7 terminal (pin 9) voltage reaches 0.6V, the capacitors (C_s) connected to the CS1-6 terminal (pin 30) start charging. The error amplifier thus provides the output voltage from channels 1 to 6 with a soft start operation in proportion to the voltage at pin CS1-6.

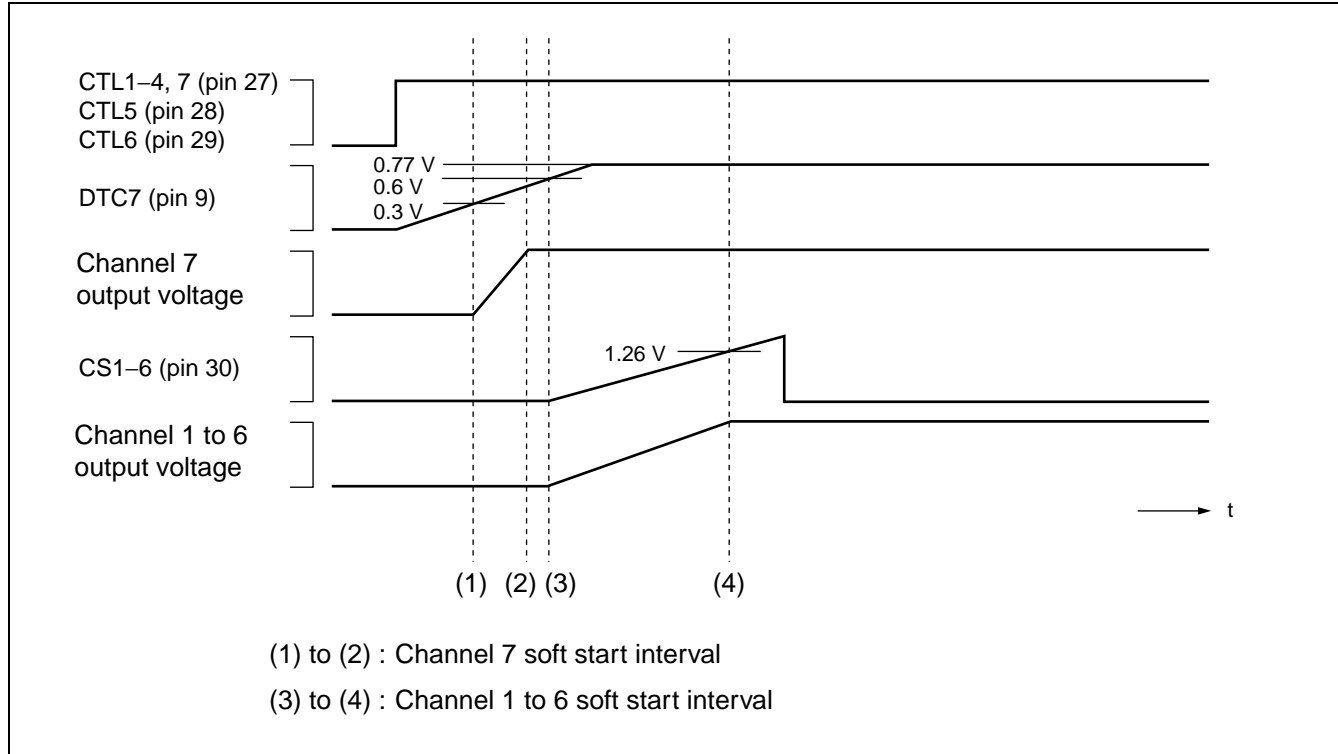

- **Starting CTL5 (CTL6) after a soft start on channels 1 to 4 and 7**

When CTL5 (CTL6) is started after a soft start on channels 1-4 and 7, the capacitor (C_s) connected to the CS1-6 terminal (pin 30) start charging. The error amplifier thus provides the output voltage from channel 5 (6) with a soft start operation in comparison with the voltage at pin CS1-6.

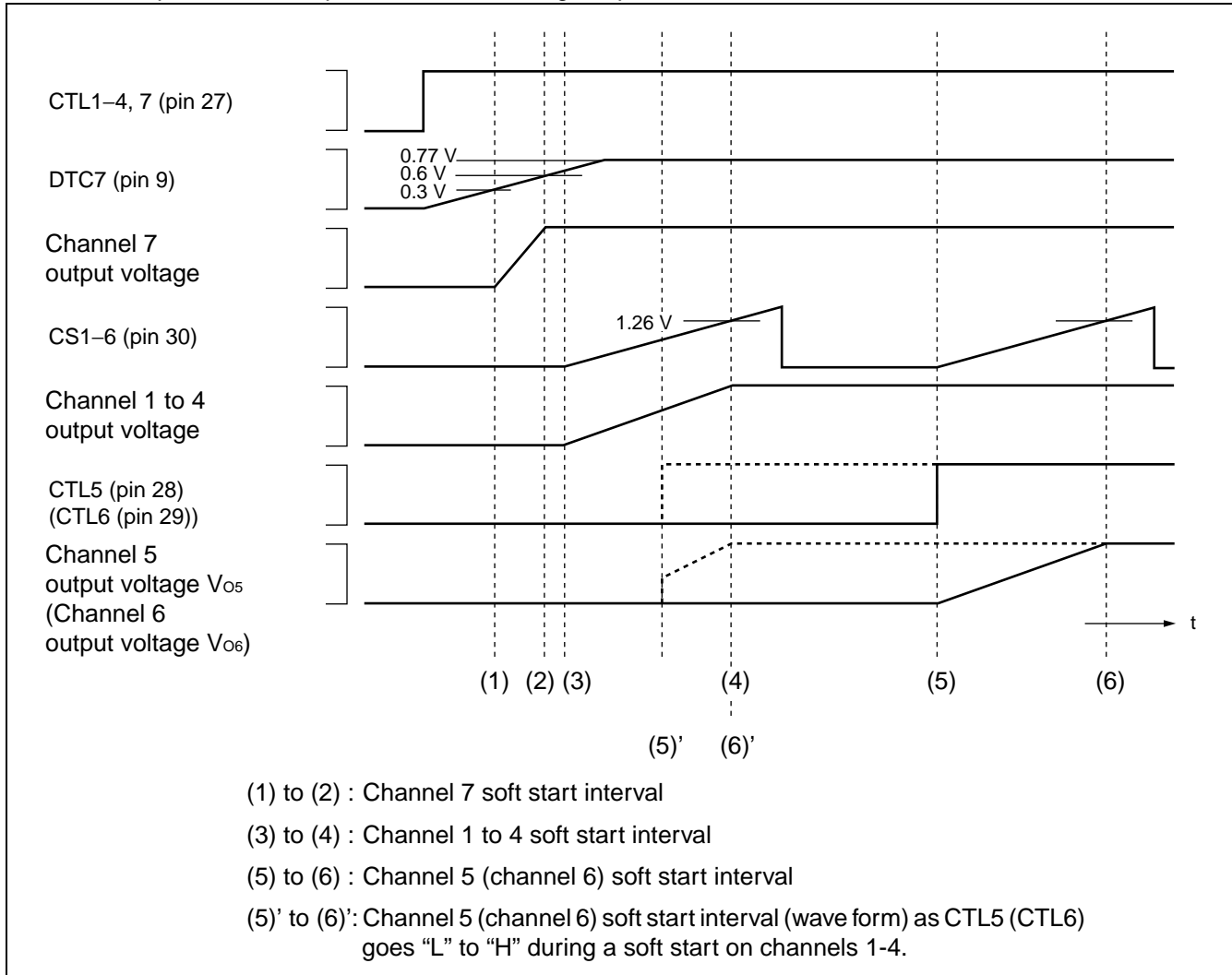

(2) Setting Methods

• Channel 7 soft start interval

Before CTL1-4, 7 are ON: V_{in} is applied along path (A) below and charges C_{FB7} .

After CTL1-4, 7 are ON: Along path (B), C_{FB7} is discharged by R2, R3, D1 at I1 to 15 μA on a time constant, and with the fall of V_{-IN7-1} , channel 7 is activated with a soft start.

Note : The short detection function is suspended while VDTC is below 0.6V.

Channel 7 equivalent circuit of soft start section

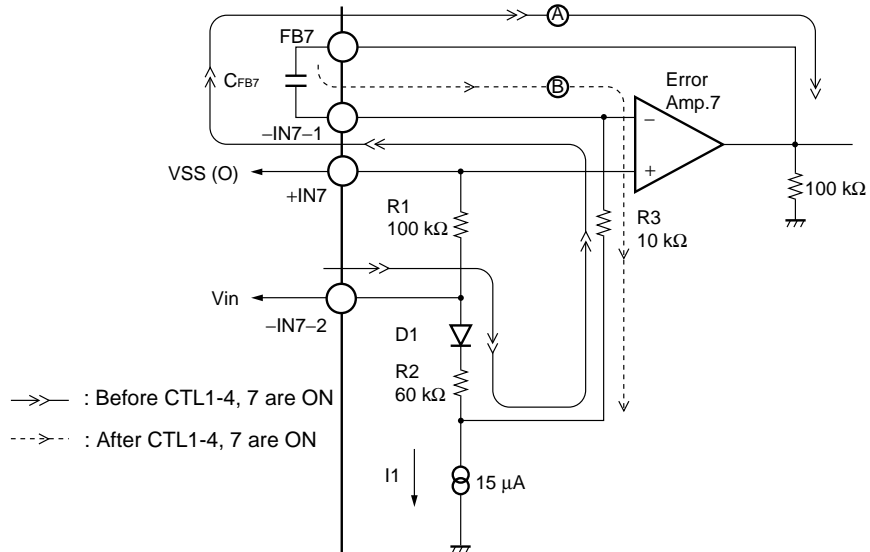

Channel 7 soft start operating waveform

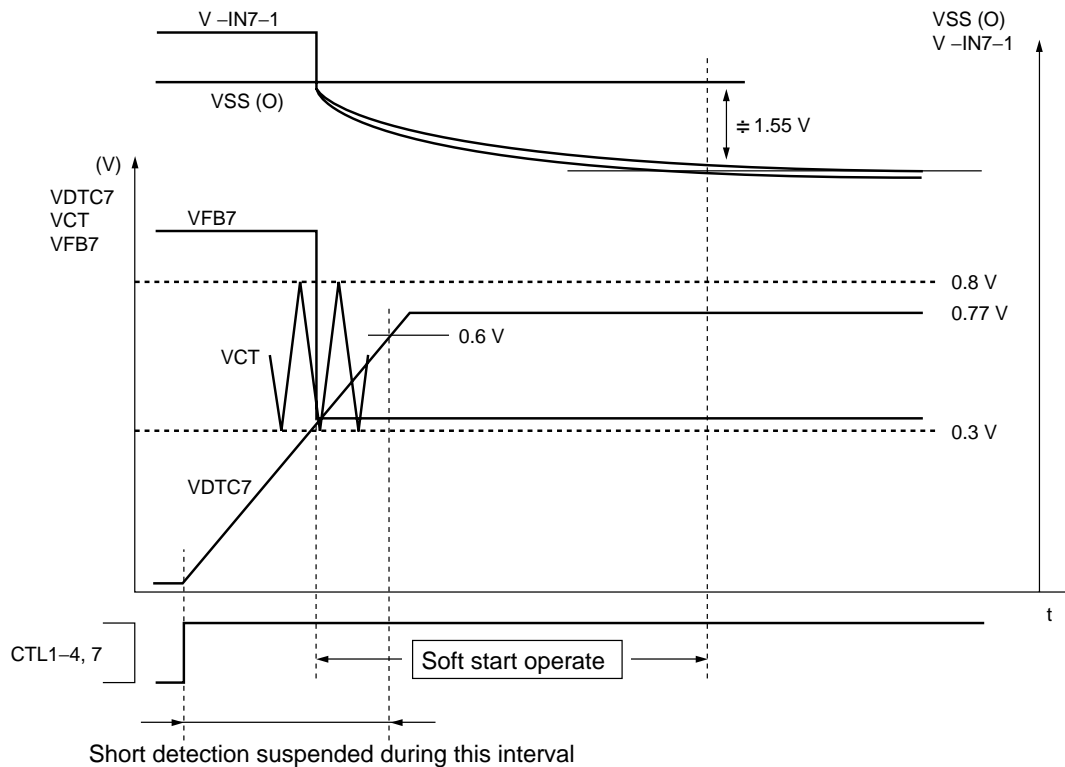

- **Channel 1 to 6 soft start time**

$$t_s(\text{sec}) \doteq 1.26 \times C_s (\mu\text{F})$$

Note : The short detection function operates during soft starts on channel 1 to channel 6.

■ METHOD OF SETTING THE OSCILLATOR FREQUENCY SETTING

The oscillator frequency can be set by the timing resistor R_T connected to the RT pin (pin 33), and the timing capacitor C_T connected to the CT pin (pin 34).

Oscillator frequency:

$$f_{\text{osc}} [\text{kHz}] \doteq \frac{900000}{C_T [\text{pF}] \times R_T [\text{k}\Omega]}$$

■ METHODS OF SETTING THE OUTPUT VOLTAGE

1. Channel 1 to 4

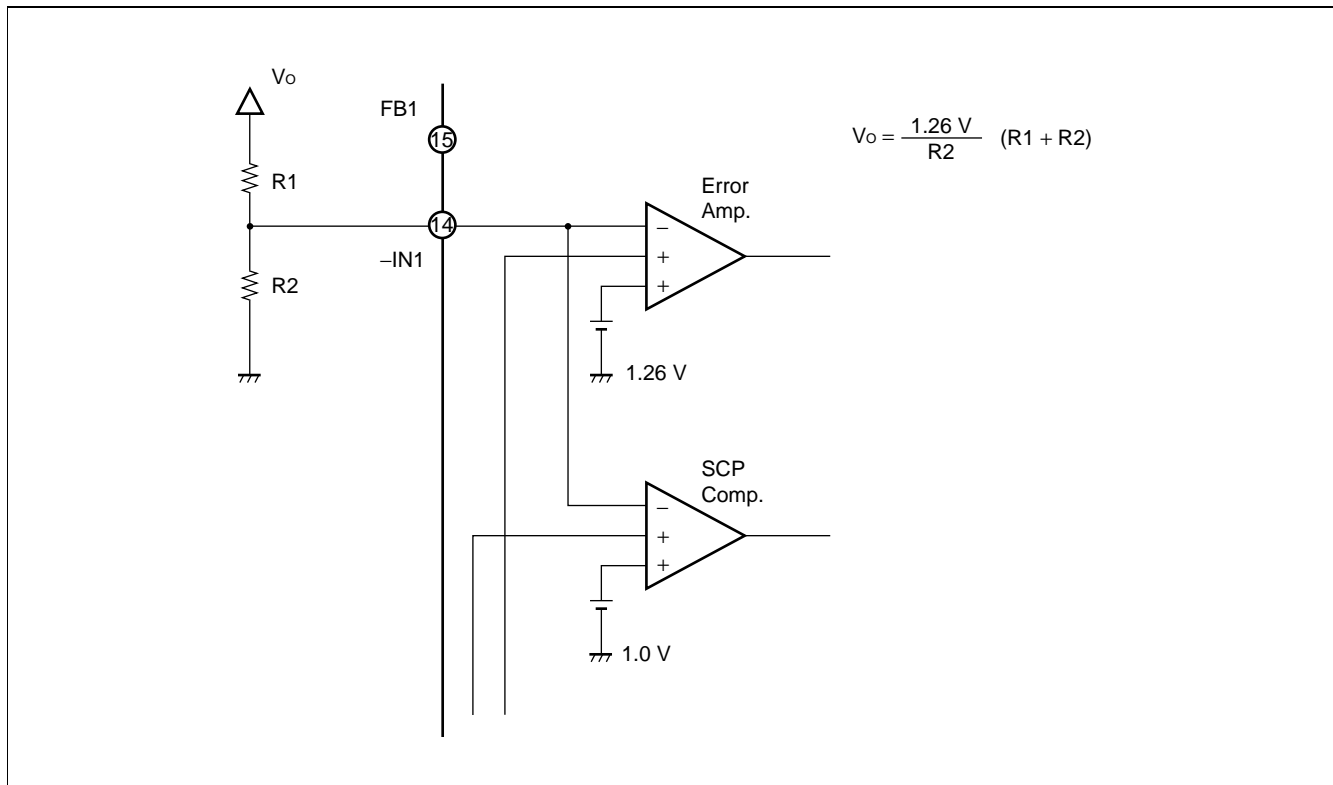

2. Channel 5

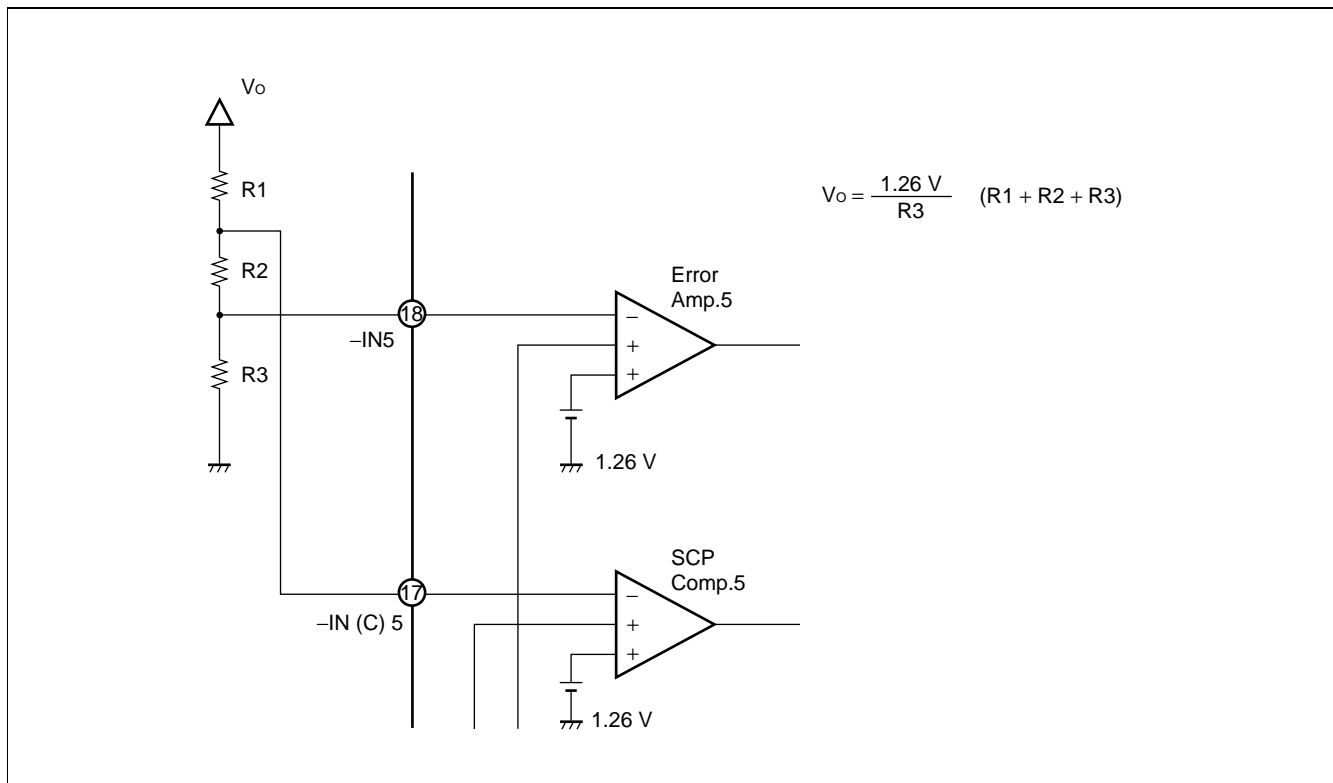

3. Channel 6

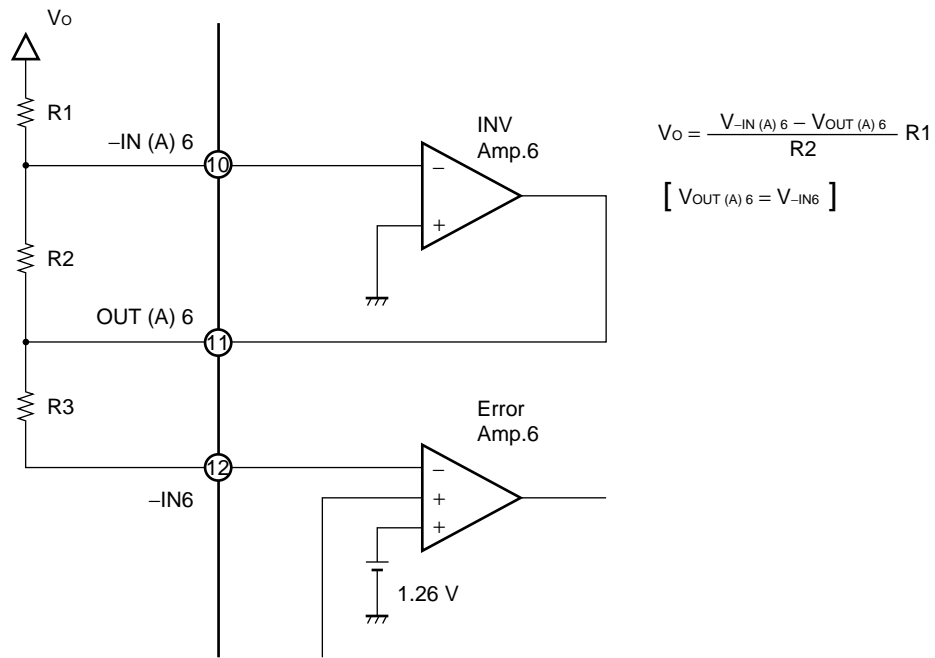

■ SAMPLE POWER SUPPLY USING SELF-POWER SUPPLY (Channel 7)

The MB3827 has a built-in self-supply channel (channel 7), capable of supplying the IC with power through transformer winding, with low input voltage ($V_{in} \geq 1.8V$) drive capability. Following figure shows a sample of a power supply using the transformer.

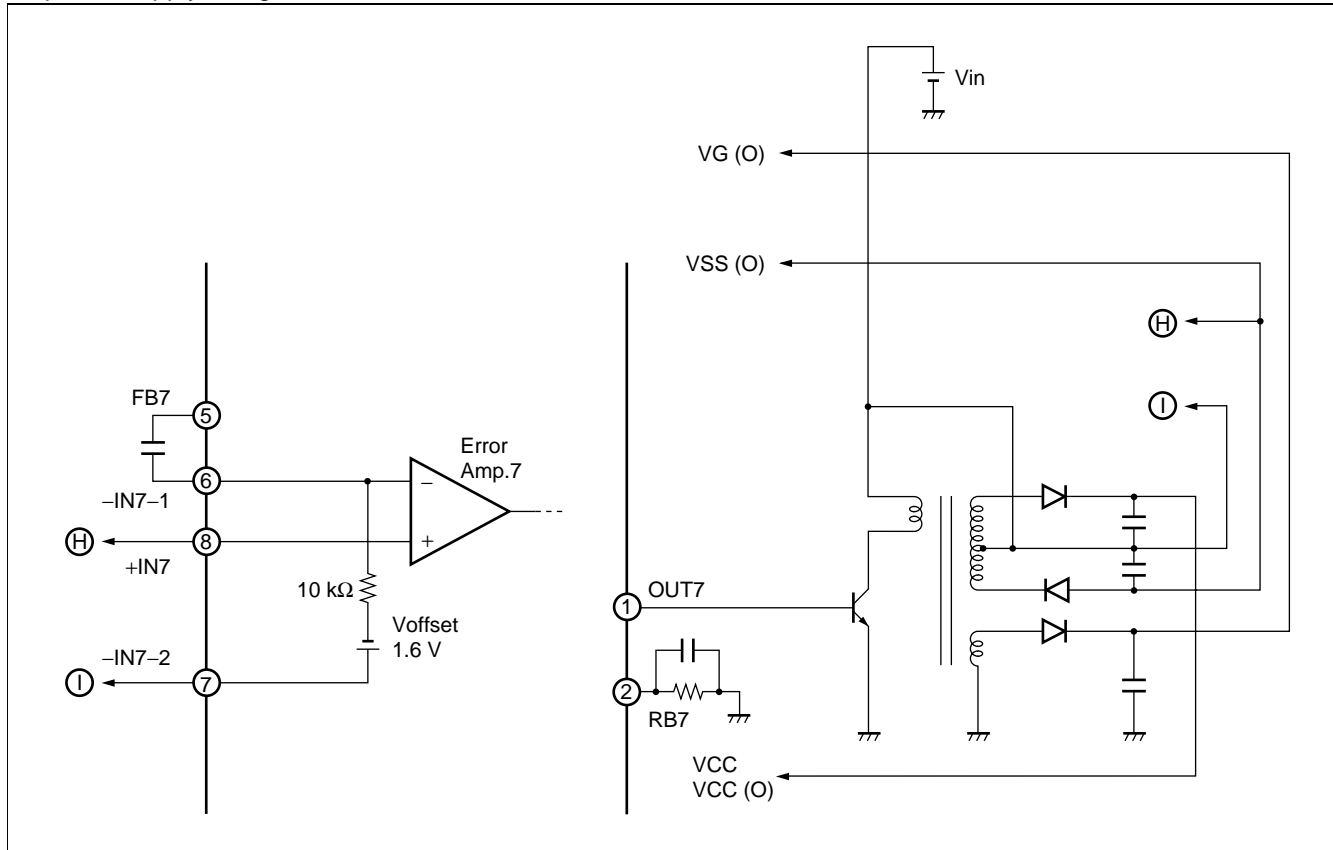

Note: The following settings are shown in "APPLICATION EXAMPLE".

- VSS(0) is $V_{in} - 1.6V$, from the voltage offset between $-IN7-1$ and $-IN7-2$.
- VCC and VCC(0) are set at the winding that produces $V_{in} + 1.6V$.
- VG(0) is set at the winding that produces 8V.

Note that because channels 1-6 operate at $V_{cc} \geq 4V$, Vcc and Vcc(0) must be set at the winding that produces $V_{in} + 2.2V$ in order to operate at $V_{in} \geq 1.8V$.

■ METHOD OF SETTING THE OUTPUT CURRENT

“Output circuit (main side)” shows the configuration of the output circuits (Drive1-3, Drive7), and “Output current waveform” illustrates how the source current value of the output current waveform has a constant current setting (When channel 1 operates as a step-up unit). Note that the source current is set by the following formula

$$\text{Output source current} = (V_B/R_B) \times 80 \approx 48/R_B \text{ [A]} \quad (V_B \approx 0.6\text{V})$$

Output circuit (main side)

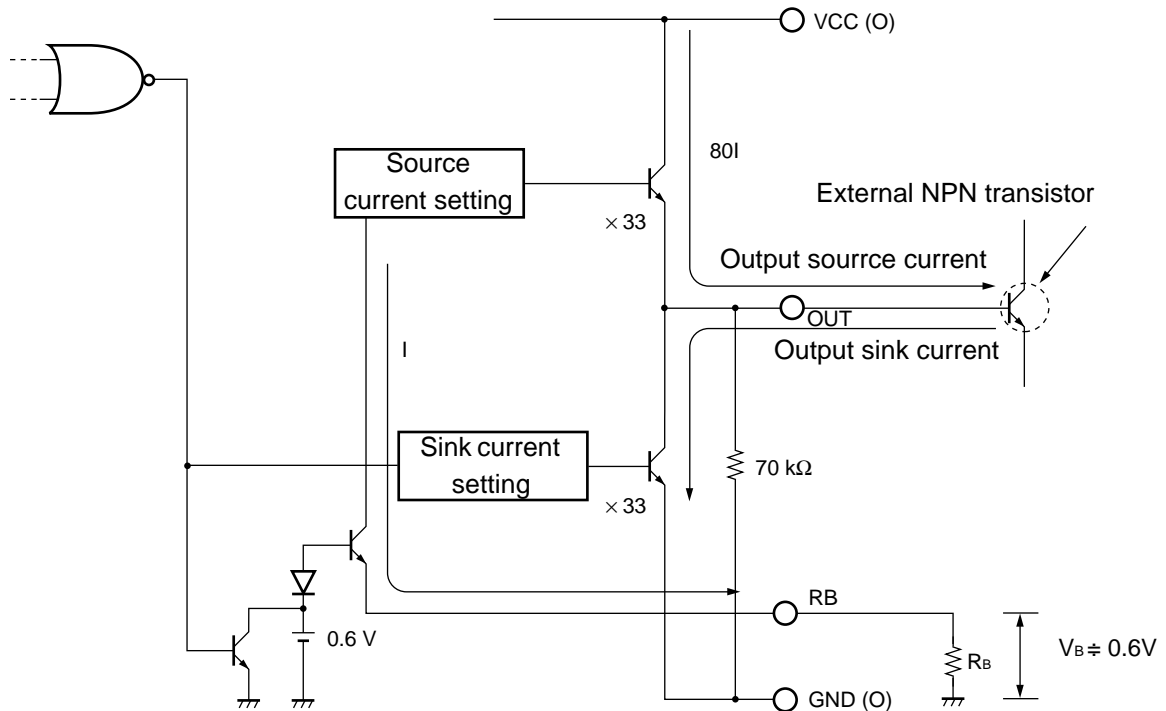

Output current waveform

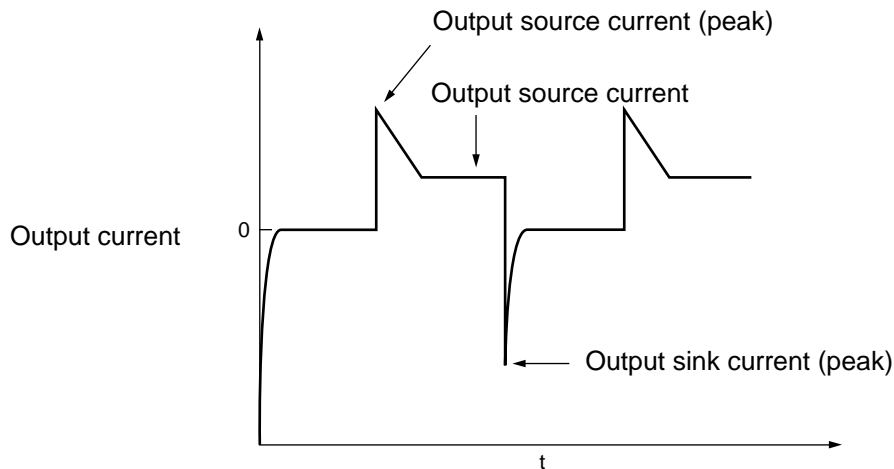

METHOD OF SETTING TIME CONSTANT FOR TIMER-LATCH SHORT PROTECTION CIRCUIT

The short detection comparator (SCP comparator) in each of the channels constantly compares the error amplifier output level to the reference voltage and the $-IN(C)8$ terminal (pin 23).

While the switching regulator load conditions are stable on all channels, or when the voltage level at the $-IN(C)8$ pin is higher than the reference voltage, LOG_SCP output remains at "H" level, transistor Q1 is on, and the CSCP terminal (pin 31) is held at input standby voltage ($V_{STB} \approx 50mV$).

If the load conditions change rapidly due to a short-circuiting of load, causing the output voltage to drop, or if the voltage at the $-IN(C)8$ terminal falls below the reference level, the output from the short detection comparator on the corresponding channel or the input at the $-IN(C)8$ terminal goes to "H" level. This causes transistor Q1 to turn off and the external short protection capacitor C_{SCP} connected to the CSCP pin to charge at $1.0 \mu A$.

Short Detection Time (t_{PE})

$$t_{PE}(\text{sec}) \approx 0.68 \times C_{SCP} (\mu F)$$

When the capacitor C_{SCP} is charged to the threshold voltage $V_{TH} \approx 0.68 V$ the SR latch is set, and the external PNP is turned off (dead time is set to 100%). At this point the SR latch input is closed and the CSCP terminal is held at input latch voltage ($V_I \approx 50 mV$).

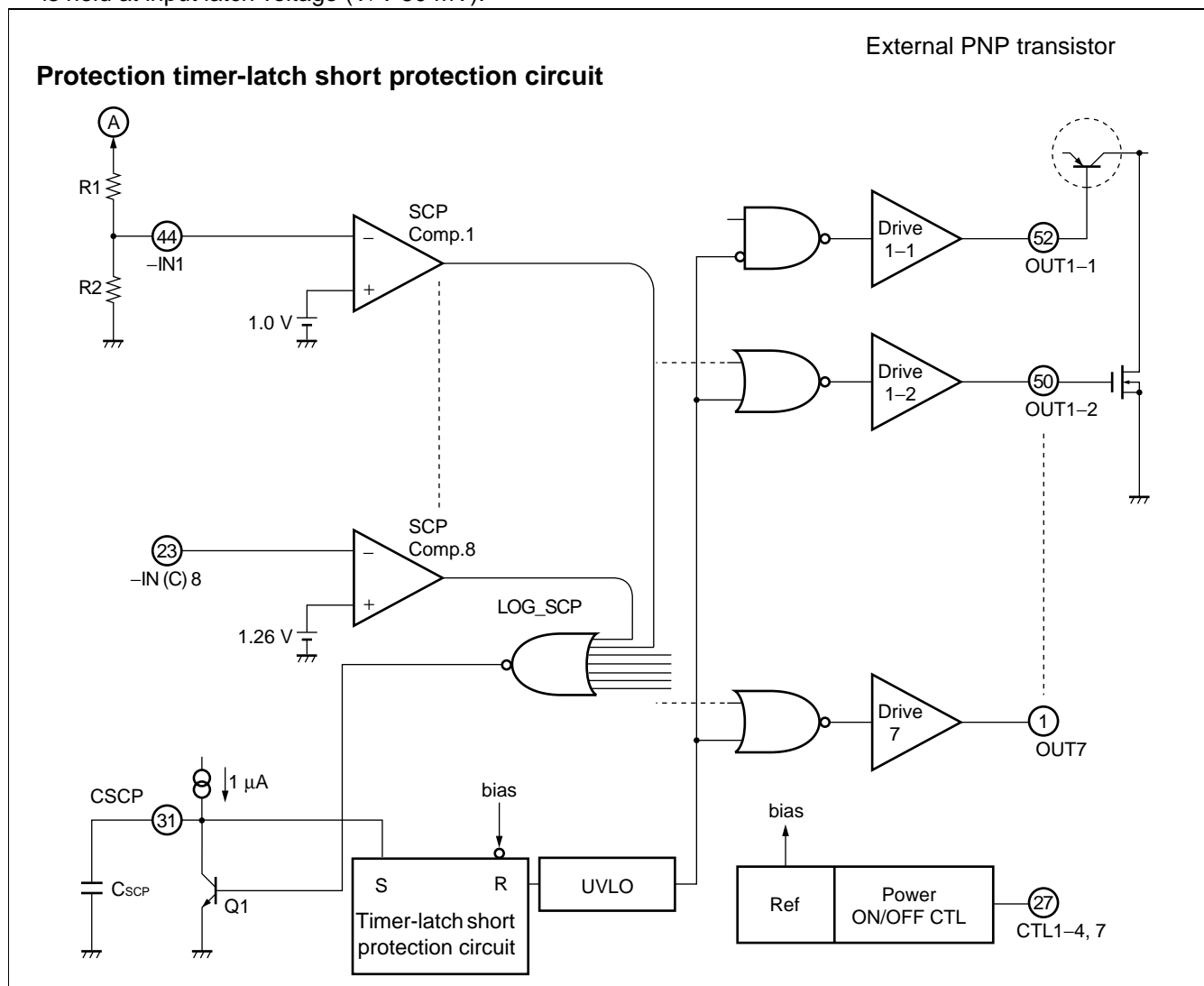

■ TREATMENT WITHOUT USING CSCP

When you do not use the timer-latch short protection circuit, connect the CSCP terminal (pin 31) to GND with the shortest distance.

Treatment when not using CSCP

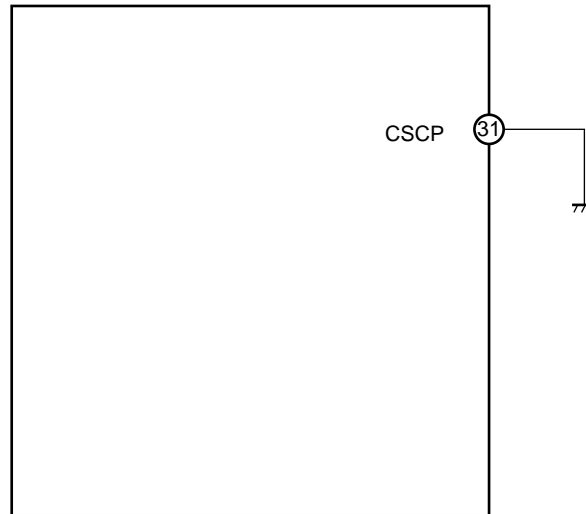

■ PROCESSING WITHOUT USING CS PIN

When not using the soft start function on channels 1 to 6, the CS1-6 terminal (pin 30) should be left open.
When not using the soft start function on channel 7, the DTC7 terminal (pin 9) should be left open.

When no soft start time is set

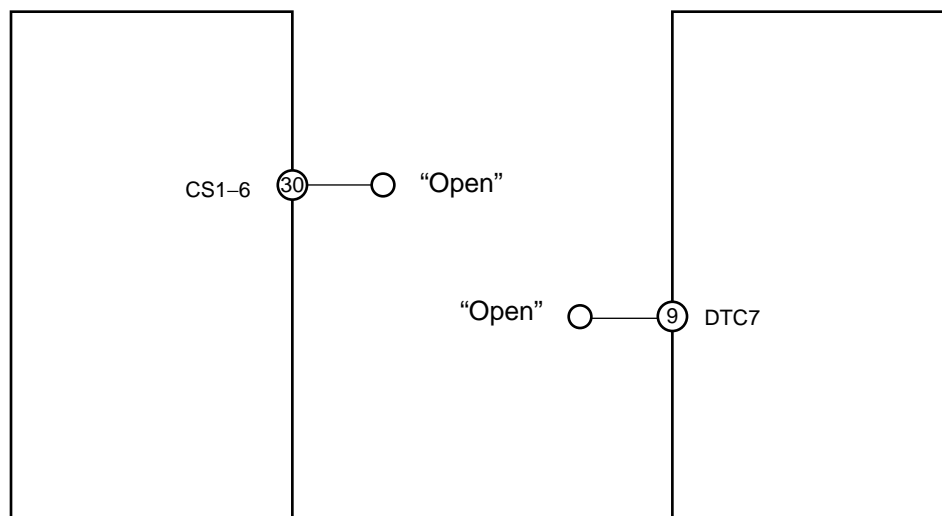

■ METHOD OF SETTING THE DEAD TIME

When setting step-up/step-down switching, Zeta type, or fly-back type step-up or inverter output, the output transistor at start-up is in full-on (ON duty cycle = 100%) state. To prevent this, the DTC voltage from the DTC1-1 terminal (pin 43) to the DTC6 terminal (pin 15) voltage is determined from the VREF voltage, as shown in following figure, so that the output transistor dead time (the maximum value of the ON interval) can be set easily.

When the voltage on the DTC5 and DTC6 terminals is lower than the triangular-wave output voltage from the oscillator, the output transistor turns off. The dead time calculation formula assuming that triangular-wave amplitude = 0.7 V and triangular-wave maximum voltage = 1.8 V is given below.

$$\text{DUTY(ON)}_{\text{max}} \approx \frac{V_{\text{dt}} - 1.1}{0.7} \times 100[\%], \quad V_{\text{dt}} = \frac{R_b}{R_a + R_b} \times V_{\text{REF}}$$

When you do not use these DTC5 and DTC6 terminals, connect them to VREF terminal (pin 24) as shown following figure (Not setting the channel 5,6 dead time).

Setting the channel 5, 6 dead time (same as for other channels)

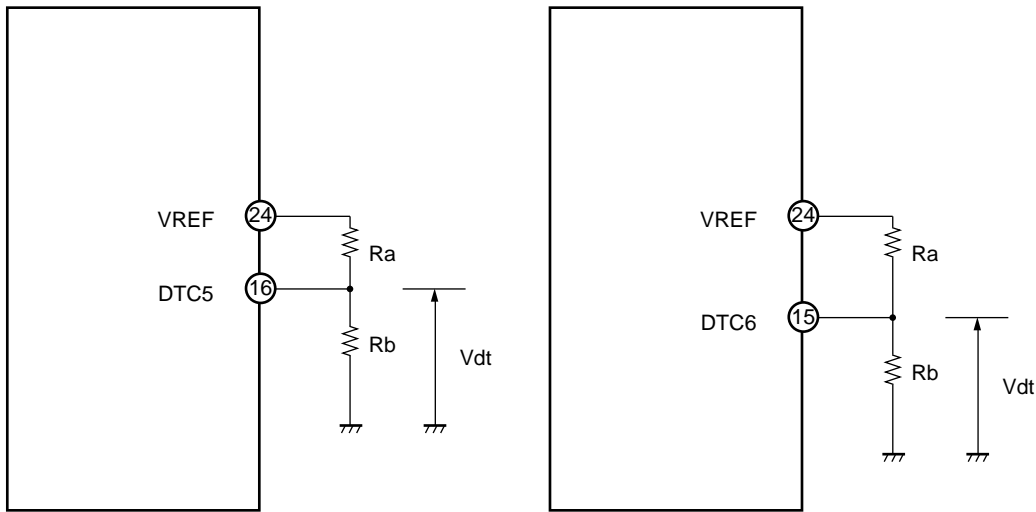

Not setting the channel 5, 6 dead time (same as for other channels)

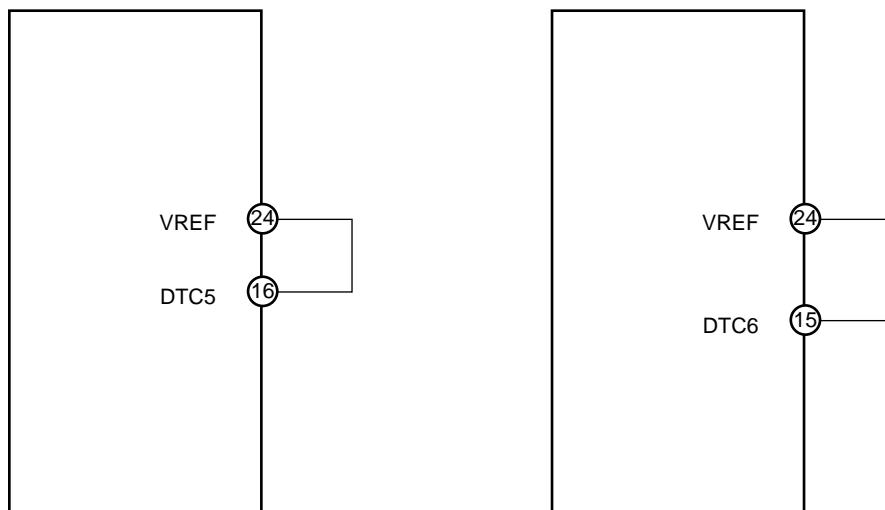

■ PROCESSING WHEN NOT USING THE XENB1-6 PIN

When V_{REF} control (channel 1 to 6 output control) is not used, the XENB1-6 terminal (pin 4) should be shorted to GND using the shortest available connection.

When not using the XENB1-6 pin

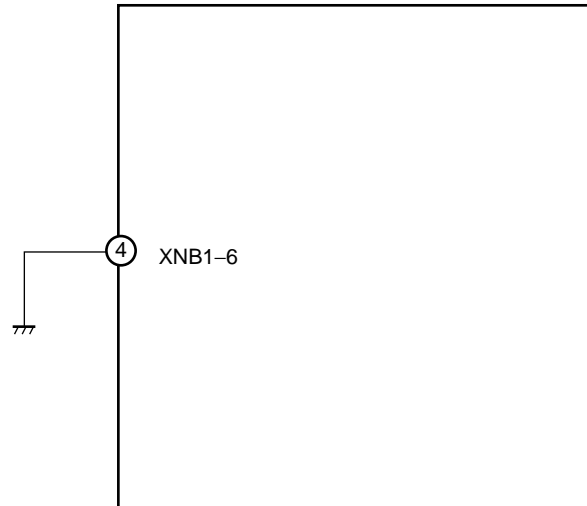

■ PROCESSING WHEN NOT USING THE CHANNEL 6 INV AMP.

When the channel 6 INV amplifier is not in use, the -IN(A)6 terminal (pin 10), and OUT(A)6 terminal (pin 11) should be shorted using the shortest available connection.

When not using the channel 6 INV Amp.

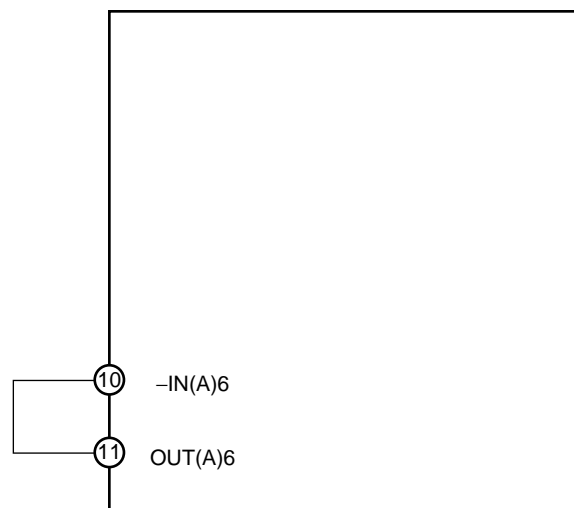

APPLICATION EXAMPLE

General view

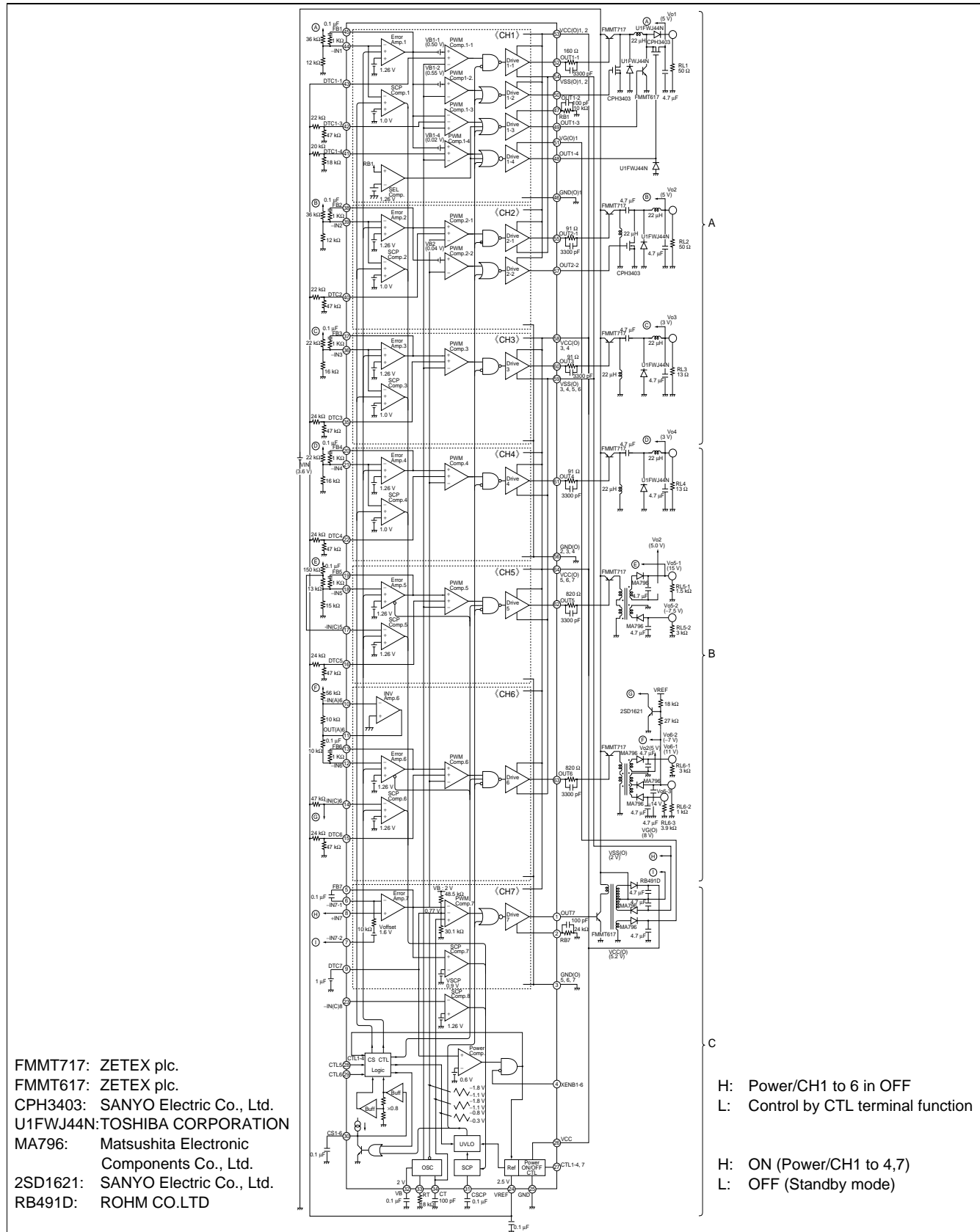

• Enlarged view of A

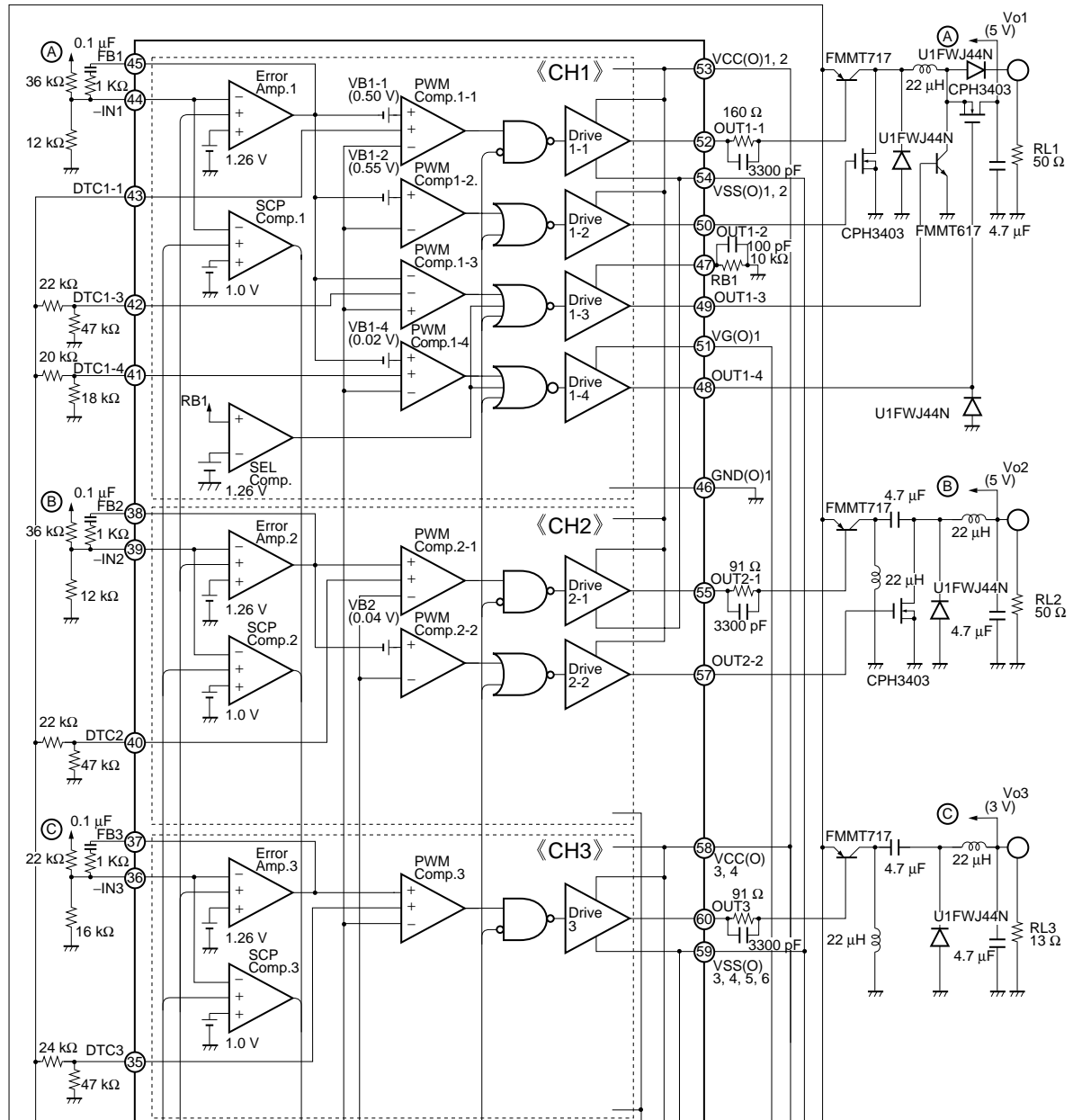

- FM7T17: ZETEX plc.
- FM7617: ZETEX plc.
- CPH3403: SANYO Electric Co., Ltd.
- U1FWJ44N: TOSHIBA CORPORATION
- MA796: Matsushita Electronic Components Co., Ltd.
- 2SD1621: SANYO Electric Co., Ltd.
- RB491D: ROHM CO.LTD

MB3827

• Enlarged view of B

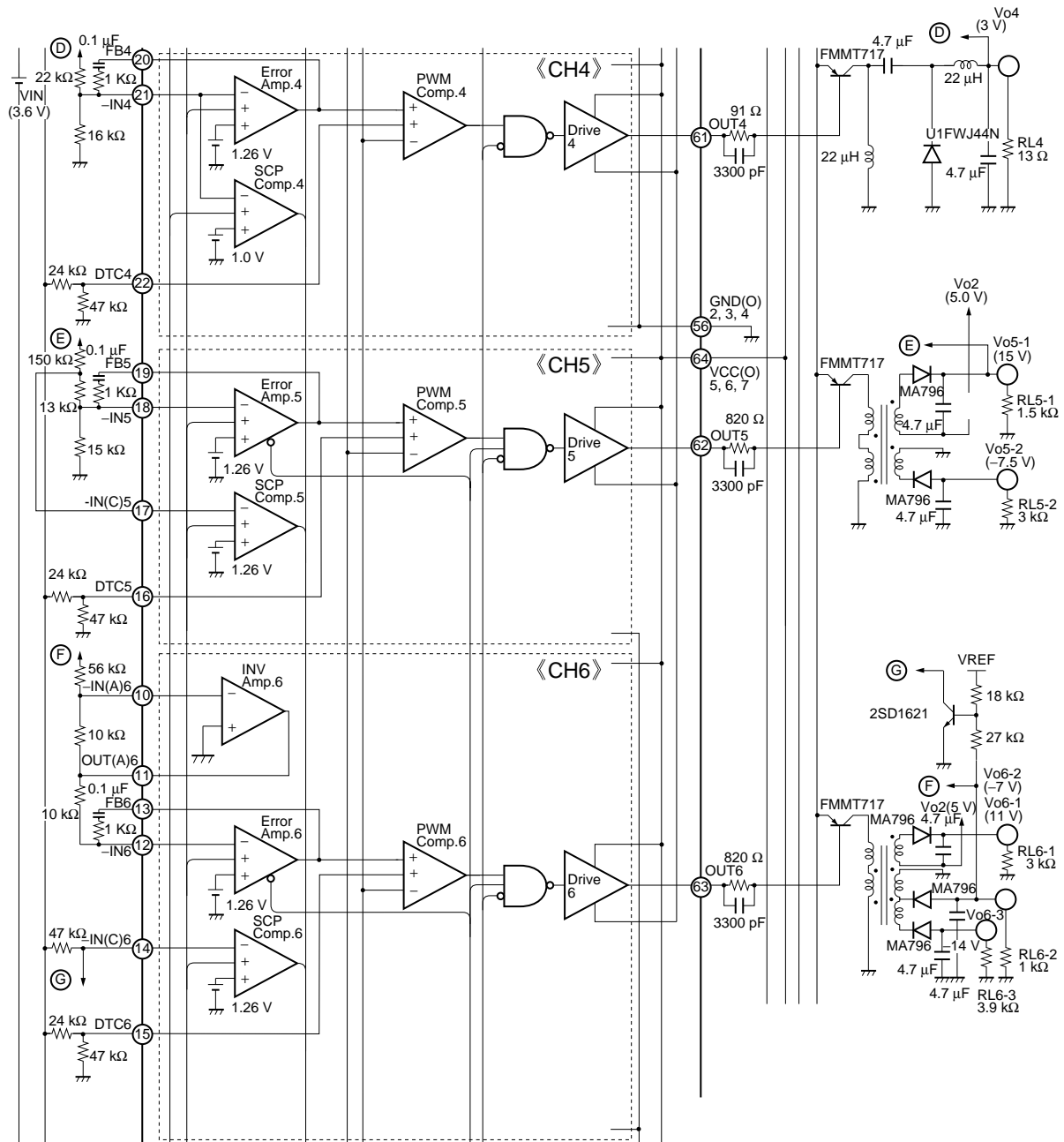

- FMMT717: ZETEX plc.
- FMMT617: ZETEX plc.
- CPH3403: SANYO Electric Co., Ltd.
- U1FWJ44N: TOSHIBA CORPORATION
- MA796: Matsushita Electronic Components Co., Ltd.
- 2SD1621: SANYO Electric Co., Ltd.
- RB491D: ROHM CO.LTD

• Enlarged view of C

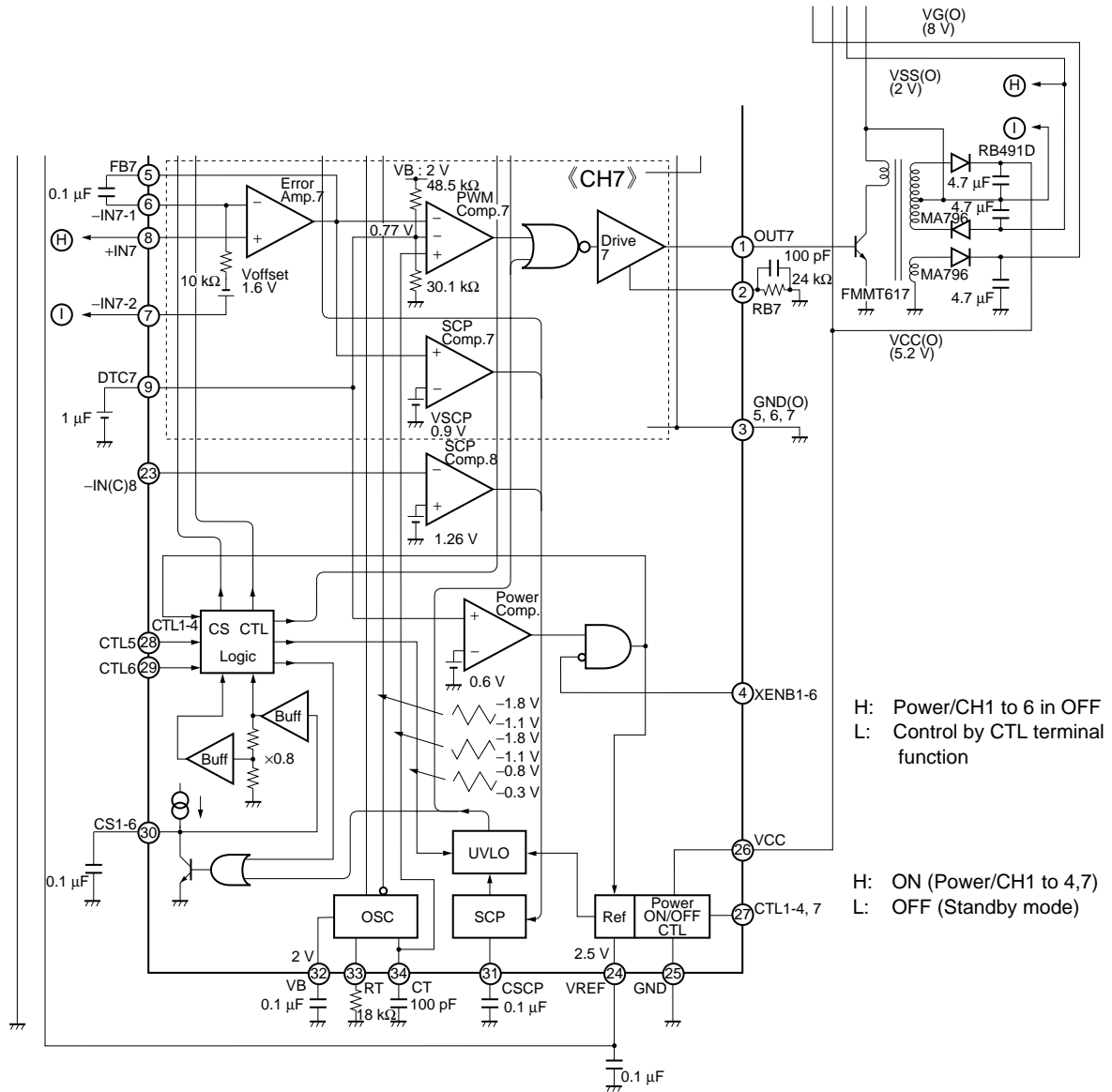

- FM717: ZETEX plc.
- FM717: ZETEX plc.
- CPH3403: SANYO Electric Co., Ltd.
- U1FWJ44N: TOSHIBA CORPORATION
- MA796: Matsushita Electronic Components Co., Ltd.
- 2SD1621: SANYO Electric Co., Ltd.
- RB491D: ROHM CO.LTD

REFERENCE DATA

Efficiency vs. load current (ch1, step-up/step-down switching method)

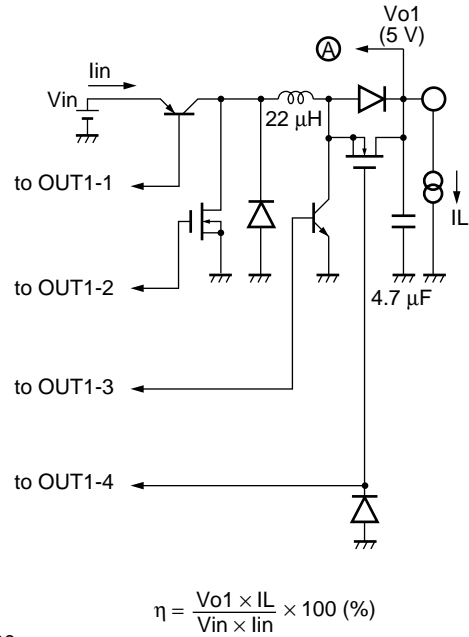
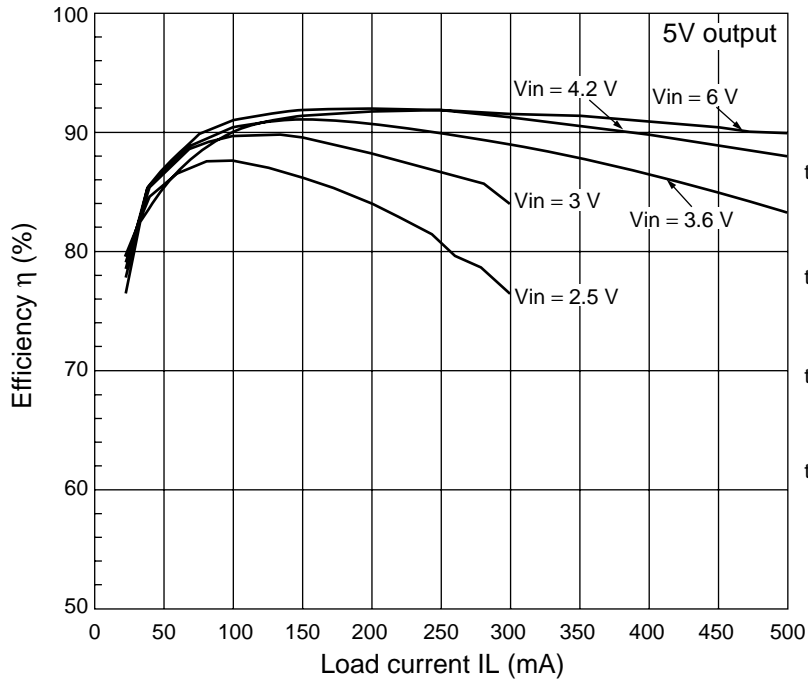

Efficiency vs. load current (ch2, Zeta Method with Synchronous Rectification)

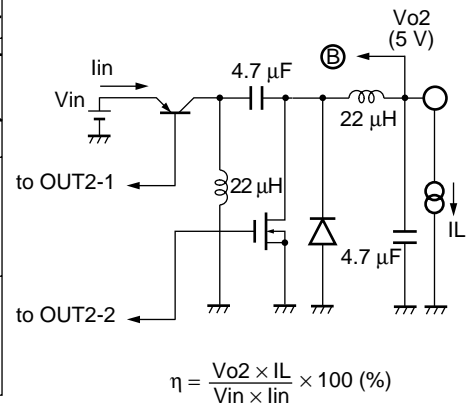
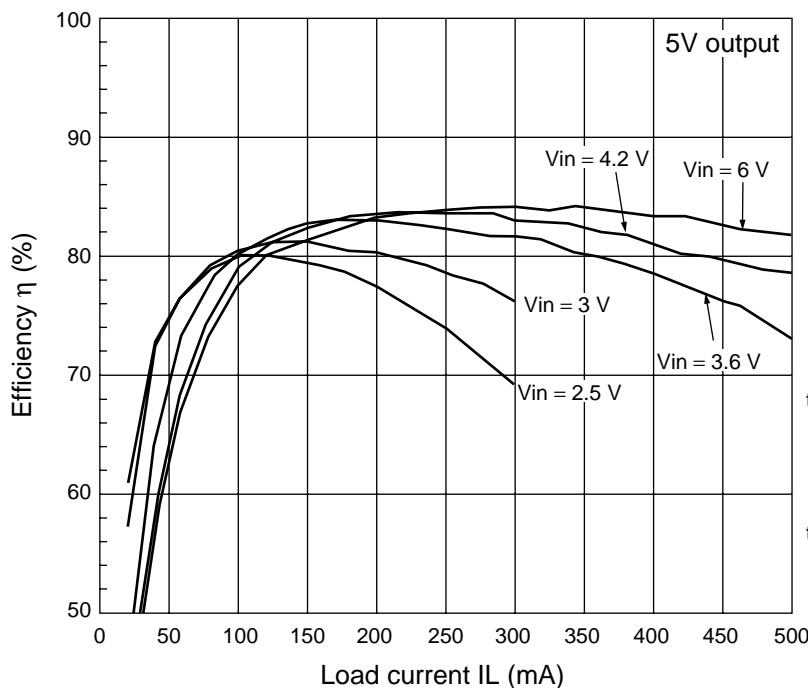

■ USAGE PRECAUTIONS

1. Never use settings exceeding maximum rated conditions.

Exceeding maximum rated conditions may cause permanent damage to the LSI. Also, it is recommended that recommended operating conditions be observed in normal use. Exceeding recommended operating conditions may adversely affect LSI reliability.

2. Use this device within recommended operating conditions.

Recommended operating conditions are values within which normal LSI operation is warranted. Standard electrical characteristics are warranted within the range of recommended operating conditions and within the listed conditions for each parameter.

3. Printed circuit board ground lines should be set up with consideration for common impedance.

4. Take appropriate static electricity measures.

- Containers for semiconductor materials should have anti-static protection or be made of conductive material.
- After mounting, printed circuit boards should be stored and shipped in conductive bags or containers.
- Work platforms, tools, and instruments should be properly grounded.
- Working personnel should be grounded with resistance of 250 kΩ to 1 mΩ between body and ground.

■ ORDERING INFORMATION

Part number	Package	Remarks
MB3827PFV	64-pin plastic LQFP (FPT-64P-M03)	

MB3827

■ PACKAGE DIMENSION

64-pin Plastic LQFP
(FPT-64P-M03)

*Pins width and pins thickness include plating thickness.

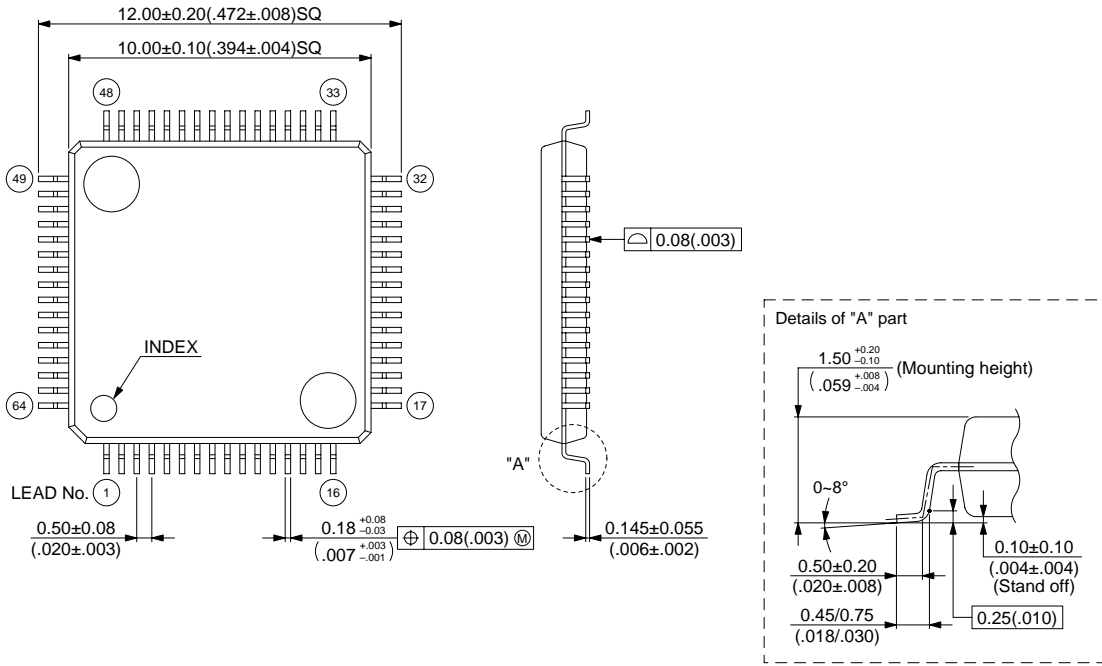

© 1998 FUJITSU LIMITED F64009S-3C-6

Dimensions in: mm (inches)

FUJITSU LIMITED

All Rights Reserved.

The contents of this document are subject to change without notice. Customers are advised to consult with FUJITSU sales representatives before ordering.

The information and circuit diagrams in this document are presented as examples of semiconductor device applications, and are not intended to be incorporated in devices for actual use. Also, FUJITSU is unable to assume responsibility for infringement of any patent rights or other rights of third parties arising from the use of this information or circuit diagrams.

The products described in this document are designed, developed and manufactured as contemplated for general use, including without limitation, ordinary industrial use, general office use, personal use, and household use, but are not designed, developed and manufactured as contemplated (1) for use accompanying fatal risks or dangers that, unless extremely high safety is secured, could have a serious effect to the public, and could lead directly to death, personal injury, severe physical damage or other loss (i.e., nuclear reaction control in nuclear facility, aircraft flight control, air traffic control, mass transport control, medical life support system, missile launch control in weapon system), or (2) for use requiring extremely high reliability (i.e., submersible repeater and artificial satellite).

Please note that Fujitsu will not be liable against you and/or any third party for any claims or damages arising in connection with above-mentioned uses of the products.

Any semiconductor devices have an inherent chance of failure. You must protect against injury, damage or loss from such failures by incorporating safety design measures into your facility and equipment such as redundancy, fire protection, and prevention of over-current levels and other abnormal operating conditions.

If any products described in this document represent goods or technologies subject to certain restrictions on export under the Foreign Exchange and Foreign Trade Law of Japan, the prior authorization by Japanese government will be required for export of those products from Japan.

F9906

© FUJITSU LIMITED Printed in Japan