

ASSP For Power Supply Applications

BIPOLAR

Switching Regulator Controller

MB3817

■ DESCRIPTION

The MB3817 is a pulse width modulator (PWM) type switching regulator controller IC designed for low-voltage and high-speed operation. This can be used in applications as down-conversion or down/up-conversion (Zeta method) .

With fewer external components and faster operating speed, the MB3817 enables reduction in power supply unit size, making it ideal for use with internal power supplies in compact, high-performance portable devices.

■ FEATURES

- Wide range of operating power supply voltages : 2.5 V to 18 V
- Built-in high-precision reference voltage generator : $1.5 \text{ V} \pm 2\%$
- High speed operation is possible : Max. 500 kHz
- Wide input voltage range of error amplifier : 0 V to $V_{CC} - 0.9 \text{ V}$
- Built-in soft start function
- Built-in timer/latch-actuated short-circuiting protection circuit
- Totem-pole type output with adjustable on/off current (for PNP transistors)
- Built-in standby function
- Small package : SSOP-16P (FPT-16P-M05)

■ PACKAGE

16-pin Plastic SSOP

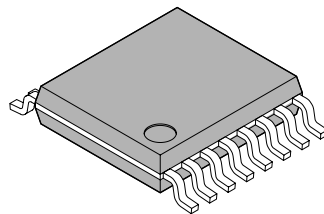

(FPT-16P-M05)

■ PIN ASSIGNMENT

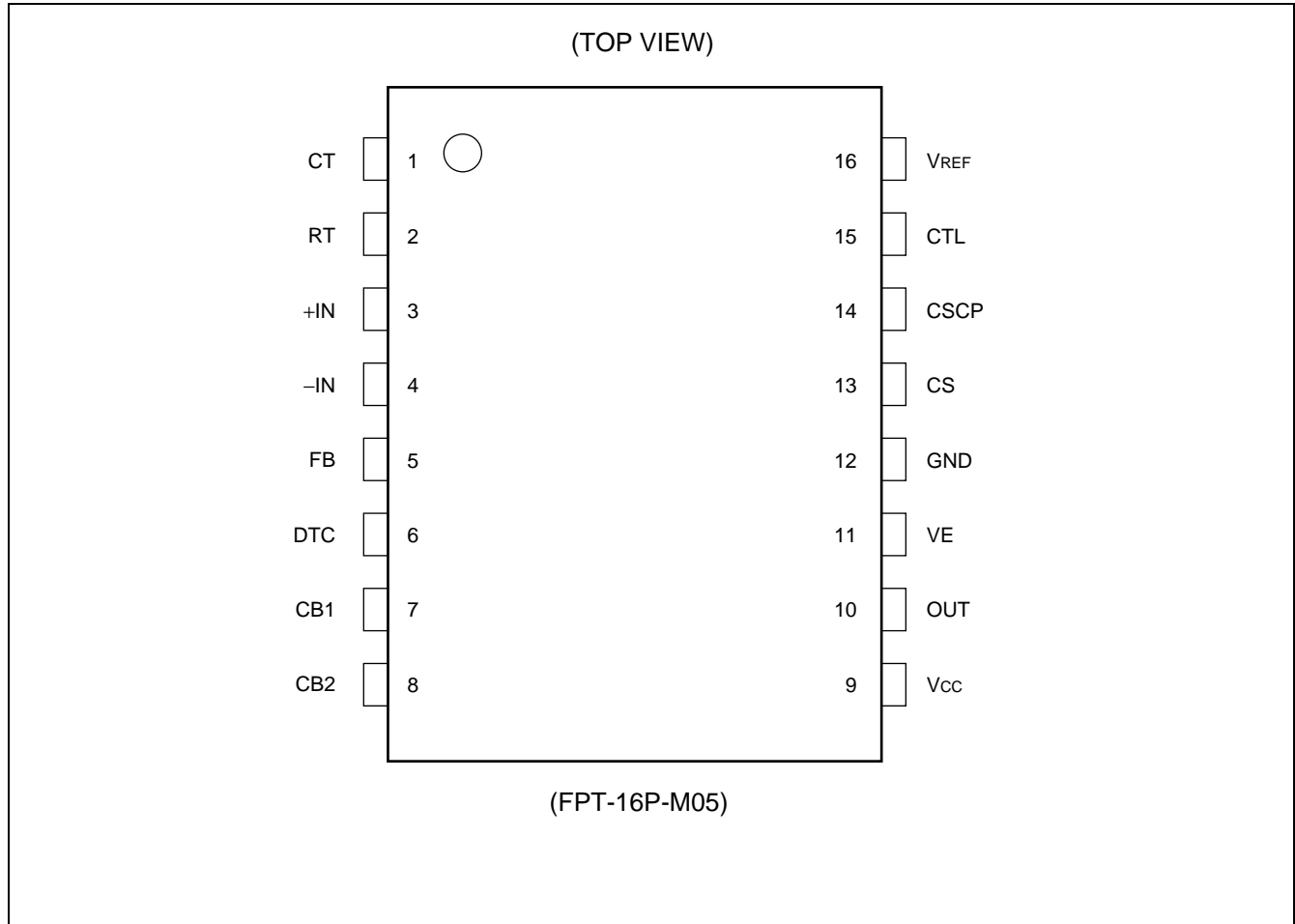

■ PIN DESCRIPTION

Pin no.	Pin name	I/O	Descriptions
1	CT	—	This terminal connects to a capacitor for setting the triangular-wave frequency.
2	RT	—	This terminal connects to a resistor for setting the triangular-wave frequency.
3	+IN	I	Error amplifier non-inverted input terminal
4	-IN	I	Error amplifier inverted input terminal
5	FB	O	Error amplifier output terminal
6	DTC	I	Dead time control terminal
7	CB1	—	Boot capacitor connection terminal
8	CB2	—	Boot capacitor connection terminal
9	V _{CC}	—	Power supply terminal
10	OUT	O	Totem-pole type output terminal
11	VE	—	Output current setting terminal
12	GND	—	Ground terminal
13	CS	—	Soft start setting capacitor connection terminal
14	CSCP	—	Short detection setting capacitor connection terminal
15	CTL	I	Power supply control terminal When this terminal is High, IC is inactive state When this terminal is Low, IC is standby state
16	V _{REF}	O	Reference voltage output terminal

MB3817

■ BLOCK DIAGRAM

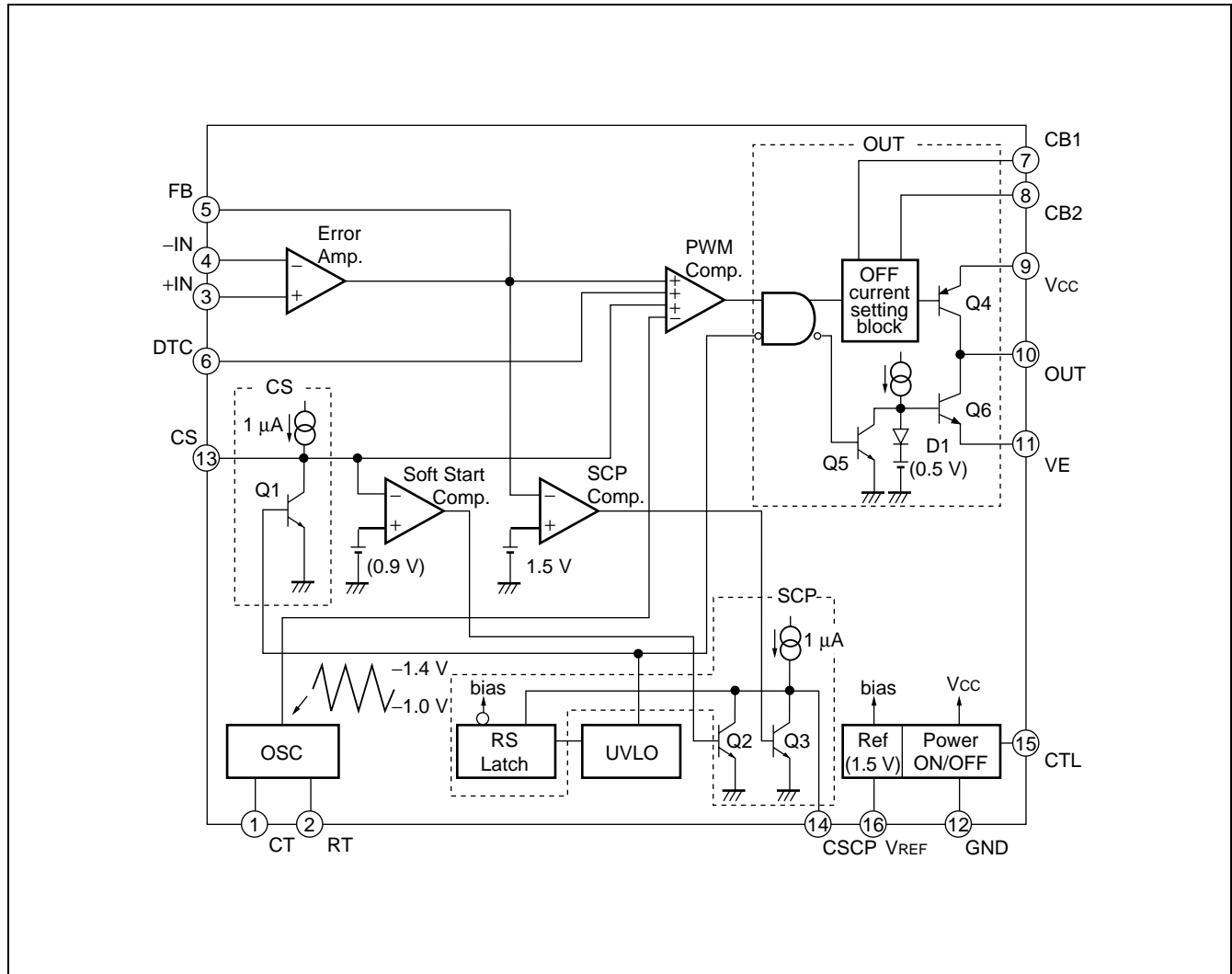

■ ABSOLUTE MAXIMUM RATINGS

Parameter	Symbol	Condition	Rating		Unit
			Min.	Max.	
Power supply voltage	V _{CC}	—	—	20	V
Power dissipation	P _D	T _a ≤ +25 °C	—	440*	mW
Storage temperature	T _{stg}	—	-55	+125	°C

* : The package is mounted on the epoxy board (10 cm × 10 cm) .

WARNING: Semiconductor devices can be permanently damaged by application of stress (voltage, current, temperature, etc.) in excess of absolute maximum ratings. Do not exceed these ratings.

■ RECOMMENDED OPERATING CONDITIONS

Parameter	Symbol	Condition	Value			Unit
			Min.	Typ.	Max.	
Power supply voltage	V _{CC}	—	2.5	6.0	18	V
Reference voltage output current	I _{OR}	—	-1	—	0	mA
Error amp. input voltage	V _{IN}	—	0	—	V _{CC} - 0.9	V
Control input voltage	V _{CTL}	—	0	—	18	V
Output current	I _O	—	3	—	30	mA
Timing capacitance	C _T	—	150	—	1500	pF
Timing resistance	R _T	—	5.1	—	100	kΩ
Oscillation frequency	f _{OSC}	—	10	200	500	kHz
Soft start capacitance	C _S	—	—	0.1	1.0	μF
Short detection capacitance	C _{SCP}	—	—	0.1	1.0	μF
Boot capacitance	C _B	—	—	—	0.1	μF
Operating temperature	T _a	—	-40	+25	+85	°C

WARNING: The recommended operating conditions are required in order to ensure the normal operation of the semiconductor device. All of the device's electrical characteristics are warranted when the device is operated within these ranges.

Always use semiconductor devices within their recommended operating condition ranges. Operation outside these ranges may adversely affect reliability and could result in device failure.

No warranty is made with respect to uses, operating conditions, or combinations not represented on the data sheet. Users considering application outside the listed conditions are advised to contact their FUJITSU representatives beforehand.

■ ELECTRICAL CHARACTERISTICS

(V_{CC} = 6 V, Ta = +25 °C)

Parameter		Symbol	Pin no.	Condition	Value			Unit
					Min.	Typ.	Max.	
Reference section (Ref)	Output voltage	V _{REF}	16	—	1.47	1.50	1.53	V
	Output temperature stability	$\frac{\Delta V_{REF}}{V_{REF}}$	16	Ta = -40°C to +85°C	—	0.5*	—	%
	Input stability	Line	16	V _{CC} = 2.5 V to 18 V	—	2	10	mV
	Load stability	Load	16	I _{OR} = 0 mA to -1 mA	—	2	10	mV
	Short circuit output current	I _{OS}	16	V _{REF} = 1 V	-10	-5	-2	mA
Under voltage lockout protection section (UVLO)	Threshold voltage	V _{TH}	13	V _{CC} = $\overline{\text{J}}$	—	2.0	2.3	V
		V _{TL}	13	V _{CC} = $\overline{\text{J}}$	1.5	1.8	—	V
	Hysteresis width	V _H	13	—	0.1	0.2	—	V
	Reset voltage	V _R	13	—	0.6	1.0	—	V
Soft start section (CS)	Threshold voltage	V _{T0}	10	Duty cycle = 0%	0.9	1.0	—	V
		V _{T100}	10	Duty cycle = 100%	—	1.4	1.5	V
	Input standby voltage	V _{STB}	13	—	—	50	100	mV
	Charge current	I _{CHG}	13	—	-1.4	-1.0	-0.6	μA
Short circuit detection section (SCP)	Threshold voltage	V _{TH}	14	—	0.60	0.65	0.70	V
	Input standby voltage	V _{STB}	14	—	—	50	100	mV
	Input latch voltage	V _I	14	—	—	50	100	mV
	Input source current	I _I	14	—	-1.4	-1.0	-0.6	μA
Triangular waveform oscillator section (OSC)	Oscillator frequency	f _{OSC}	10	C _T = 330 pF R _T = 6.2 kΩ	450	500	550	kHz
	Frequency voltage stability	$\Delta f/f_{dv}$	10	V _{CC} = 3.6 V to 16 V	—	1	10	%
	Frequency temperature stability	$\Delta f/f_{dt}$	10	Ta = -40°C to +85°C	—	1*	—	%

* : Standard design value.

(Continued)

(Continued)

($V_{CC} = 6\text{ V}$, $T_a = +25\text{ }^\circ\text{C}$)

Parameter	Symbol	Pin no.	Condition	Value			Unit	
				Min.	Typ.	Max.		
Error amp. section (Error Amp.)	Input offset voltage	V_{IO}	3, 4	$V_{FB} = 1.2\text{ V}$	—	—	10	mV
	Input offset current	I_{IO}	3, 4	$V_{FB} = 1.2\text{ V}$	—	—	100	nA
	Input bias current	I_I	3, 4	$V_{FB} = 1.2\text{ V}$	-200	-100	—	nA
	Common mode input voltage range	V_{CM}	3, 4	—	0	—	$V_{CC} - 0.9$	V
	Common mode rejection ratio	CMRR	5	DC	60	100	—	dB
	Voltage gain	A_V	5	DC	60	100	—	dB
	Frequency bandwidth	BW	5	$A_V = 0\text{ dB}$	—	800*	—	kHz
	Maximum output voltage width	V_{OM}^+	5	—	1.8	2.0	—	V
		V_{OM}^-	5	—	—	50	500	mV
	Output sink current	I_{O^+}	5	$V_{FB} = 1.2\text{ V}$	60	120	—	μA
	Output source current	I_{O^-}	5	$V_{FB} = 1.2\text{ V}$	—	-2.0	-0.6	mA
Dead time control section (DTC)	Threshold voltage	V_{T0}	10	Duty cycle = 0%	0.9	1.0	—	V
		V_{T100}	10	Duty cycle = 100%	—	1.4	1.5	V
	ON duty cycle	Dtr	10	$V_{DTC} = V_{REF} \times 0.88$ $C_T = 330\text{ pF}$, $R_T = 6.2\text{ k}\Omega$	70	80	90	%
	Input current	I_{DTC}	6	$V_{DTC} = 0\text{ V}$	-500	-250	—	nA
PWM comparator section (PWM Comp.)	Threshold voltage	V_{T0}	10	Duty cycle = 0%	0.9	1.0	—	V
		V_{T100}	10	Duty cycle = 100%	—	1.4	1.5	V
	Input sink current	I_{I^+}	5	—	60	120	—	μA
	Input source current	I_{I^-}	5	—	—	-2.0	-0.6	mA
Output section (OUT)	Output sink current	I_{O^+}	10	$R_E = 15\text{ k}\Omega$	18	30	42	mA
	Output source current	I_{O^-}	10	Duty $\leq 5\%$	—	-100	-50	mA
	Standby leakage current	I_{LO}	10	$V_{CC} = 18\text{ V}$, $V_O = 18\text{ V}$	—	—	10	μA
Control section (CTL)	Input on condition	V_{ON}	11	—	2.1	—	18	V
	Input off condition	V_{OFF}	11	—	0	—	0.7	V
Input current	I_I	15	$V_{CTL} = 5\text{ V}$	—	100	200	μA	
Standby current	I_{CCS}	9	$V_{CTL} = 0\text{ V}$	—	—	10	μA	
Power supply current	I_{CC}	9	Output "H"	—	2.7	4.0	mA	

* : Standard design value.

TYPICAL CHARACTERISTICS

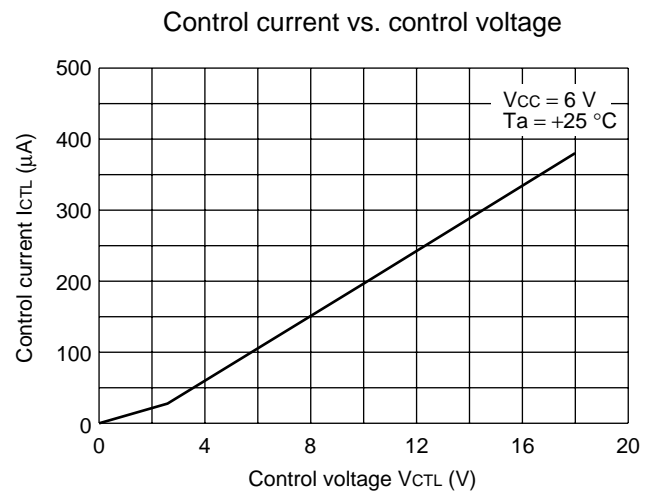
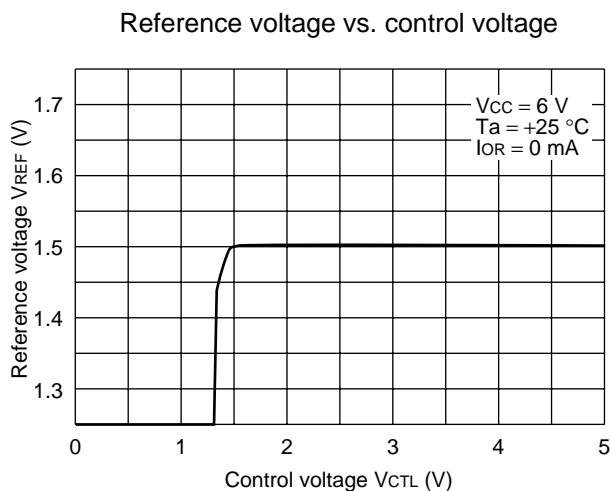
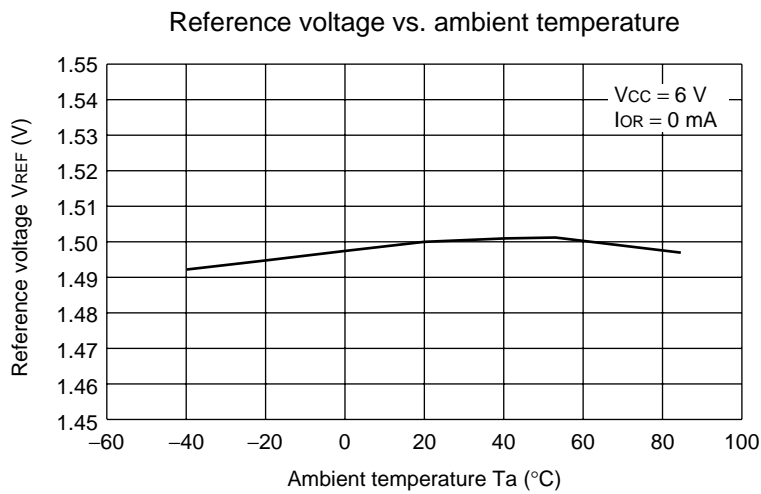
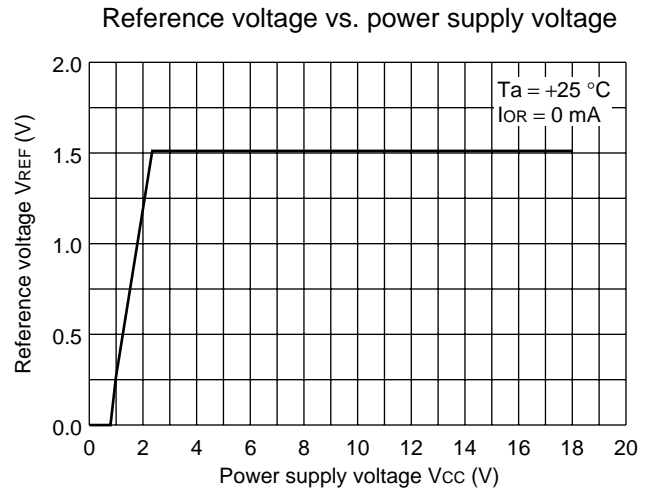
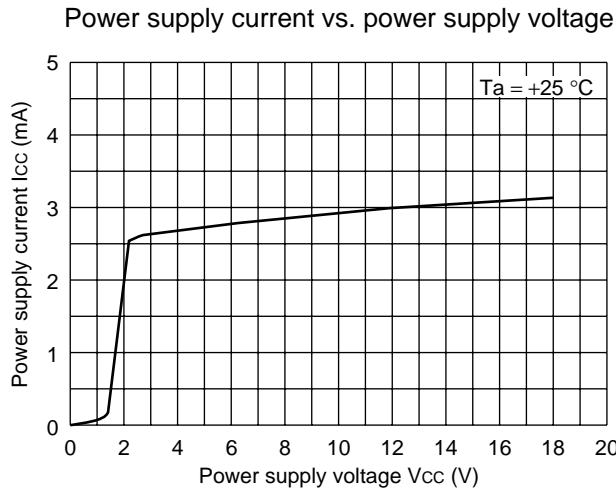

(Continued)

Triangular wave frequency vs. timing resistance

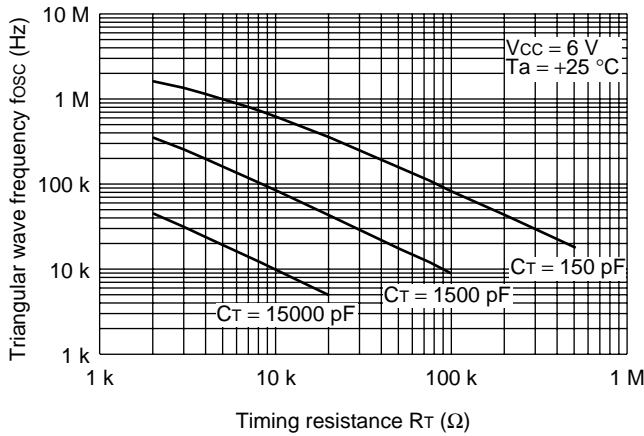

Triangular wave maximum amplitude voltage vs. timing capacitance

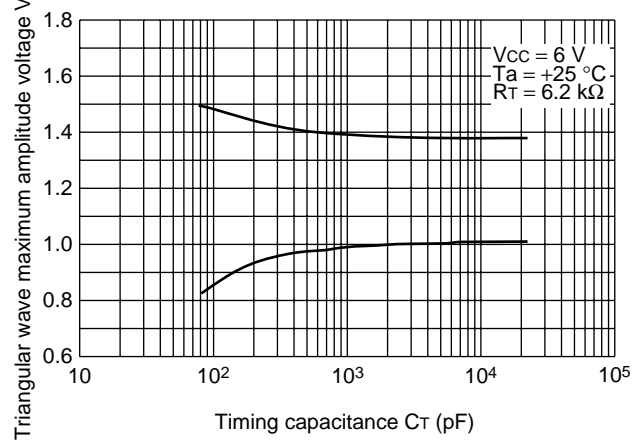

Duty vs. triangular wave frequency

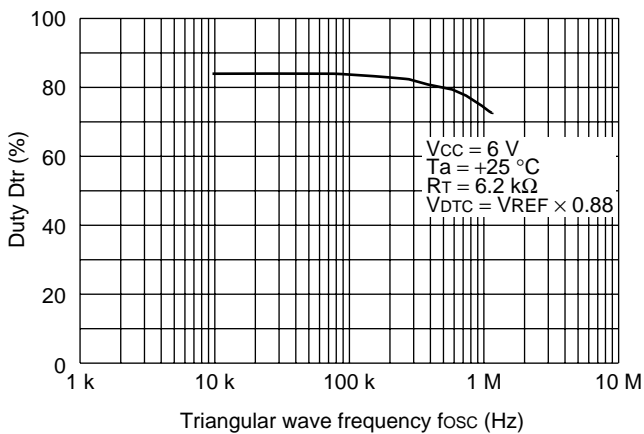

Triangular wave cycle vs. timing capacitance

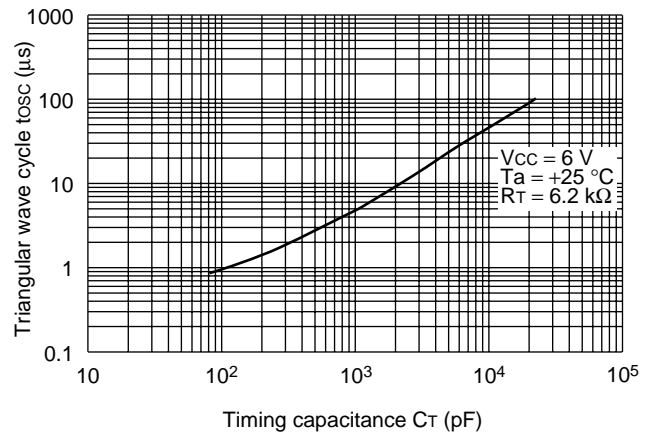

Frequency stability vs. ambient temperature

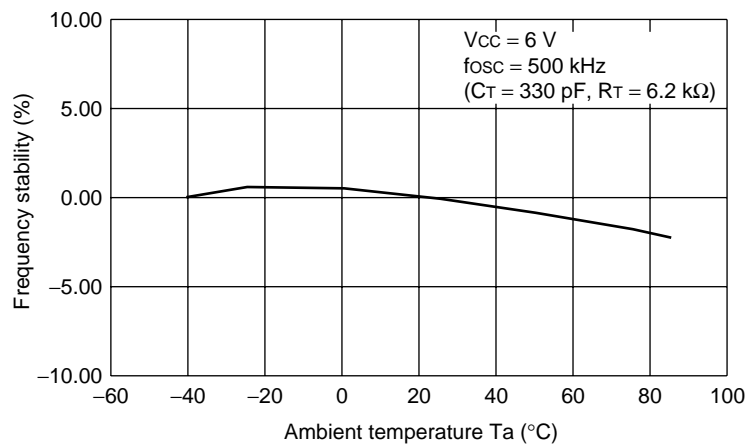

(Continued)

(Continued)

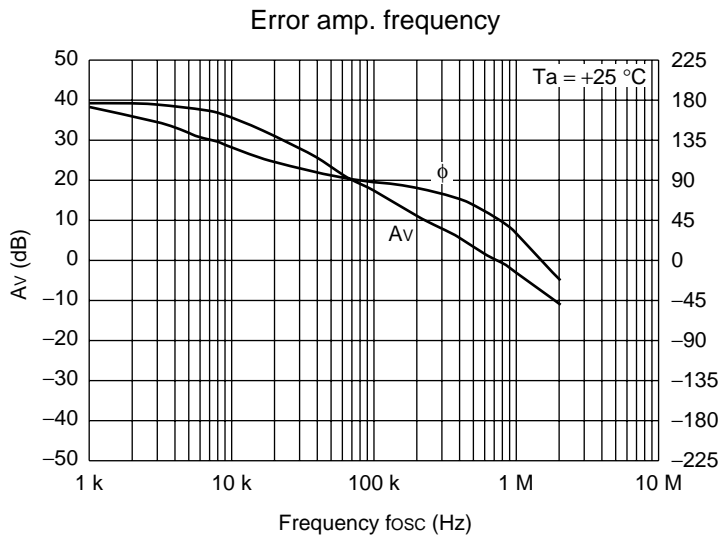

• Measurement circuit

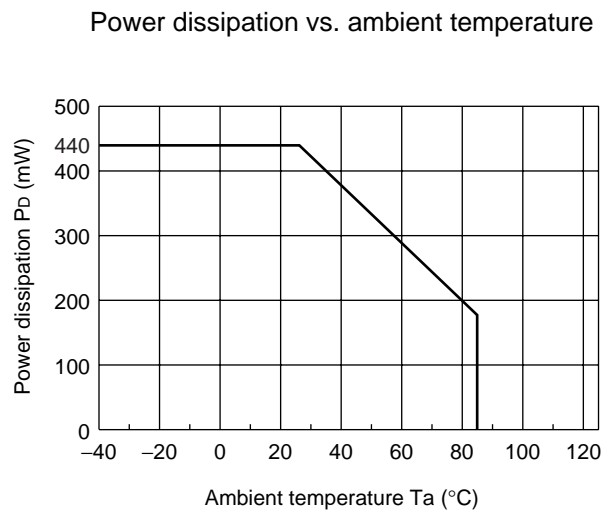
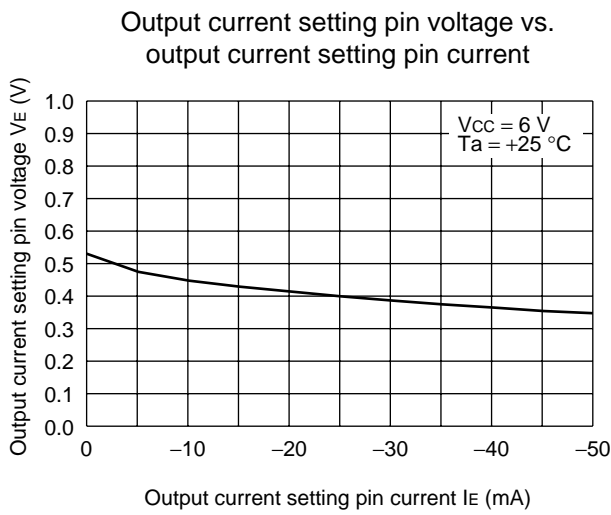
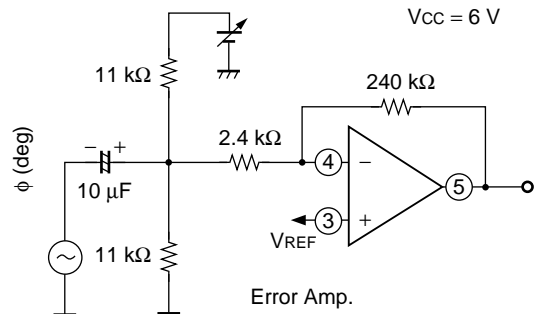

■ FUNCTIONAL DESCRIPTION

1. Switching Regulator Functions

(1) Reference voltage circuit (Ref)

The reference voltage circuit generates a temperature-compensated stable voltage ($\approx 1.50\text{ V}$). This reference voltage is used as the reference voltage and bias level for the power control unit.

(2) Triangular-wave oscillator circuit

By connecting a timing capacitor and a resistor to the C_T (pin1) and the R_T (pin2) terminals, it is possible to generate any desired triangular oscillation waveform.

(3) Error amplifier

The error amp. is an amplifier circuit that detects the output voltage from the switching regulator and produces the PWM control signal. The broad in-phase input voltage range of 0 V to $V_{CC} - 0.9\text{ V}$ provides easy setting from external power supplies and enables use with applications such as DC motor speed control systems.

Also, it is possible to provide stable phase compensation for a system by setting up any desired level of loop gain, by connecting feedback resistance and a capacitor between the error amp. output terminal (FB terminal (pin 5)) and the inverse input terminal ($-IN$ terminal (pin 4)).

(4) PWM comparator (PWM Comp.)

This is a voltage comparator with one inverted input and three non-inverted inputs, and operates as a voltage-pulse width modulator controlling output duty in relation to input voltage.

The output transistor is turned on during the interval in which the triangular waveform is lower than any of three voltages : the error amp. output voltage (FB terminal (pin 5)), soft start set voltage (CS terminal (pin 13)), or dwell time setting voltage (DTC terminal (pin 6)).

(5) Output circuits (OUT)

The output circuit has totem pole type configuration, and can drive an external PNP transistor.

The on current value can be set up to a maximum of 30 mA using the resistance (R_E) connected to the VE terminal (pin 11).

The off current is set by connecting a bootstrap capacitor C_B between the CP1 terminal (pin 7) and CP2 terminal (pin 8).

2. Power Supply Control Functions

The output is switched on and off according to the voltage level at the CTL terminal (pin 15).

CTL terminal voltage level	Channel on/off status
L ($\leq 0.7\text{ V}$)	Standby mode*
H ($\geq 2.1\text{ V}$)	Operating mode

* : Supply current in standby mode is $10\text{ }\mu\text{A}$ or less.

3. Protective Circuit Functions

(1) Soft start and short protection circuits (CS, SCP)

Soft starting, by preventing a rush current at power-on, can be provided by connecting a capacitor C_S to the CS terminal (pin 13).

After the soft start operation is completed, the CSCP terminal (pin 14) is held at "L" level (standby voltage V_{STB}), which functions as short detection standby mode. If an output short causes the error amp. output to rise above 1.5 V , capacitor C_{SCP} begins charging, and after reaching threshold voltage V_{TH} of 0.65 V causes the OUT terminal (pin 10) to be fixed at "H" level and the dwell time to be set to 100%, and the CSCP terminal (pin 14) is held at "L" level.

Once the protection circuit has been activated, the power supply must be reset to restore operation.

(2) Low input voltage error prevention circuit (UVLO)

Power-on surges and momentary drops in power supply voltage can cause errors in control IC operation, which can destroy or damage systems. The low input voltage error protection circuit compares the supply voltage to the internal reference voltage, and sets the OUT terminal (pin 10) to “H” level in the event of a drop in supply voltage.

Operation is restored when the power supply voltage returns above the threshold voltage of the low input voltage error prevention circuit.

SETTING OUTPUT VOLTAGE

- Output voltage V_o is plus

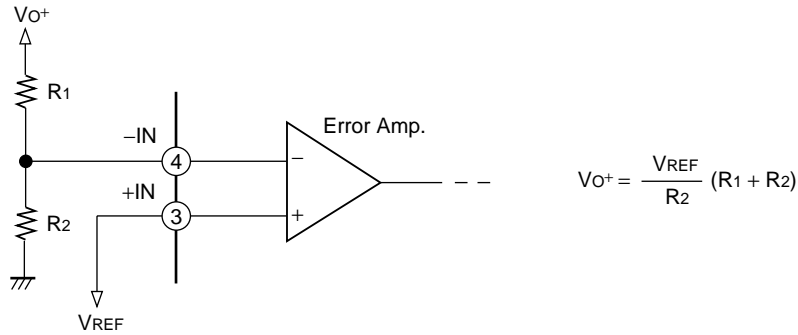

- Output voltage V_o is minus

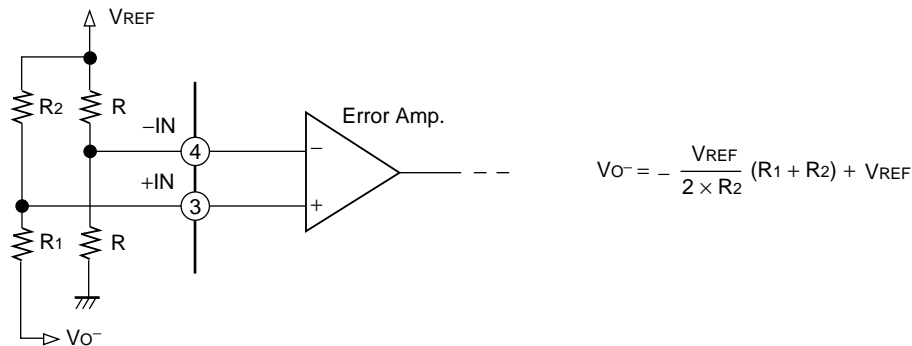

OSCILATOR FREQUENCY SETTING

The oscillator frequency can be set by connecting a timing capacitor (C_T) to the CT terminal (pin1) and a timing resistor (R_T) to the RT terminal (pin2).

Oscillator frequency : f_{osc}

$$f_{osc} \text{ (kHz)} \cong \frac{1023000}{C_T \text{ (pF)} \cdot R_T \text{ (k}\Omega)}$$

■ METHOD OF SETTING THE OUTPUT CURRENT

The output circuit is comprised of a totem-pole configuration. Its output current waveform is such that the ON-current value is set by constant current and the OFF-current value is set by a time constant. These output currents are set using the equations below.

$$\text{ON current : } I_{o^+} [\text{mA}] \approx \frac{500}{R_E [\Omega]} \quad (\text{Voltage on output current-setting pin } V_E = 0.5 \text{ V})$$

OFF current : OFF-current time constant = proportional to the value of C_B

• Output circuit

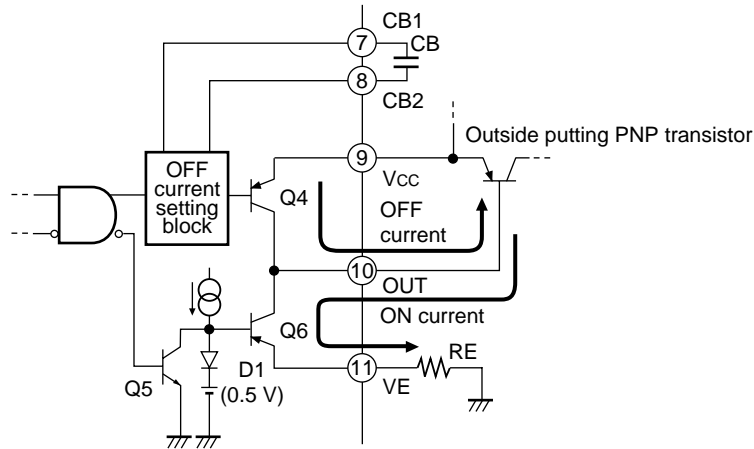

• Output current waveform

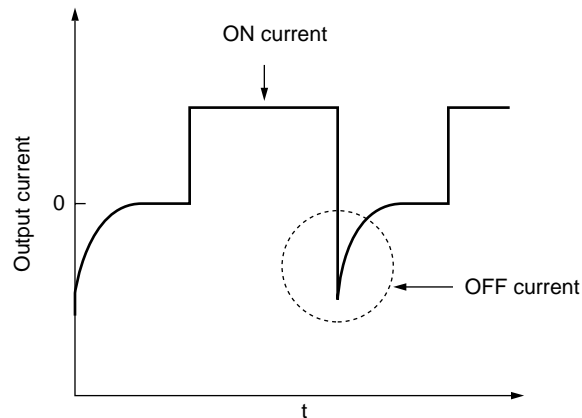

- Voltage and current waveforms on output terminal

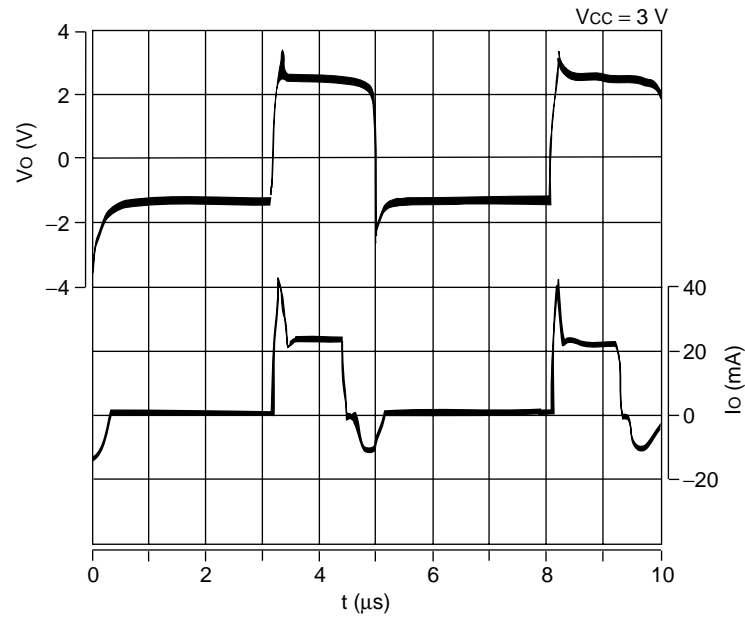

- Measuring circuit diagram

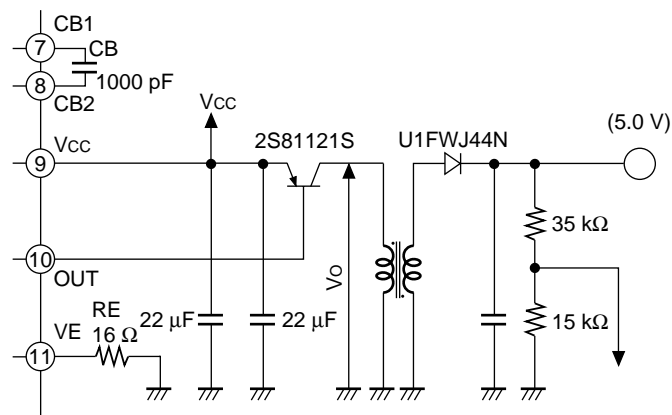

■ TREATMENT WHEN NOT USING CSCP

When you do not use the timer/latch-actuated short-circuiting protection circuit, connect the CSCP terminal (pin 14) to GND.

- Treatment when not using CSCP

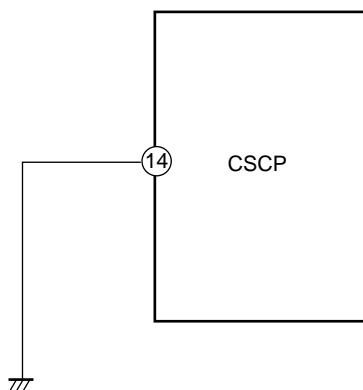

METHOD OF SETTING SOFT START TIME

To protect against surge currents when the IC is turned on, a soft start setting can be made by connecting a soft start capacitor (C_s) to the CS terminal (pin 13) .

When the IC starts up (CTL terminal (pin 15) to "H" level, $V_{CC} \geq$ UVLO threshold voltage V_{TH}) the transistor Q1 turns off and the soft start capacitor (C_s) connected to the CS terminal begins charging from the charge current I_{CHG} which is $-1.0 \mu A$.

At this time, if the CS terminal voltage is less than 0.9 V, the soft start comparator circuit output goes to "H" level, transistor Q2 turns on and the CSCP terminal (pin 14) holds input standby voltage V_{STB} which is 50 mV so that the short protection circuit is not activated. When the CS terminal voltage is greater than or equal to 0.9 V, transistor Q2 turns off, the PWM comparator circuit compares the CS terminal voltage with the triangular wave and changes the ON duty of the OUTPUT terminal, thus achieving a soft start. Note that the soft start time is determined by the following formula.

Soft start time (time before output ON duty reaches 50%)

$$t_s [\text{ms}] \approx 1.2 \times C_s [\mu\text{F}]$$

• Soft start circuit

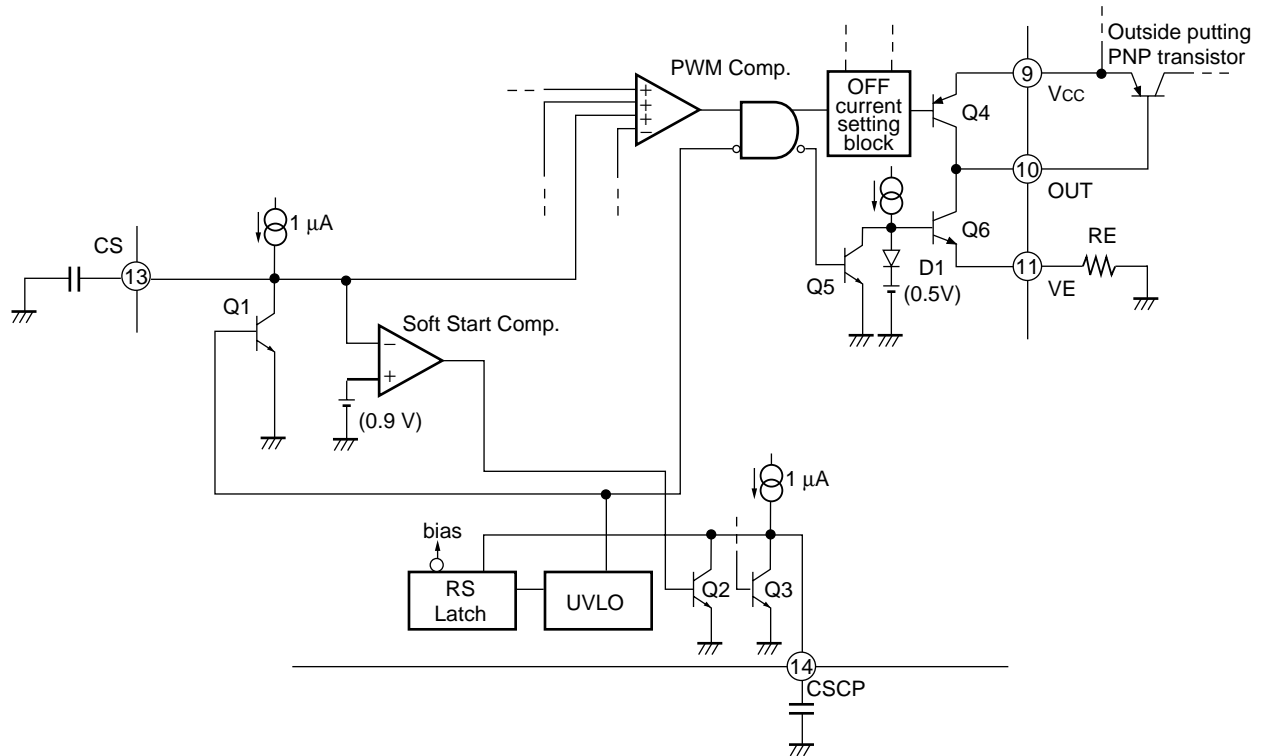

■ TREATMENT WHEN NOT USING CS

When not using the soft start function, the CS terminal (pin 13) should be left open.

- When no soft start time is set

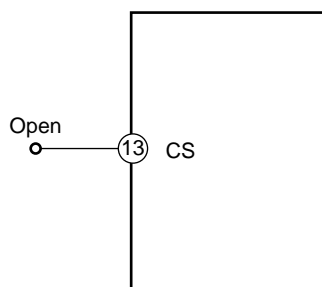

■ METHOD OF SETTING THE DEAD TIME

When the device is set for step-up inverted output based on the flyback method, the output transistor is fixed to a full-on state (ON-duty = 100%) at power switch-on. To prevent this problem, you may determine the voltages on the DTC terminals (pin 6) from the V_{REF} voltage so you can easily set the output transistor's dead time (maximum ON-duty) independently for each channel as shown below.

When the voltage on the DTC terminals (pin 6) is lower than the triangular-wave output voltage from the oscillator, the output transistor turns off. The dead time calculation formula assuming that triangular-wave amplitude $\cong 0.4$ V and triangular-wave minimum voltage $\cong 1.4$ V is given below.

$$\text{Duty (ON)}_{\text{MAX}} \cong \frac{V_{dt} - 1.0 \text{ V}}{0.4} \times 100 [\%]$$

When you do not use these DTC terminals, connect them to V_{REF} terminal.

• When using DTC to set dead time

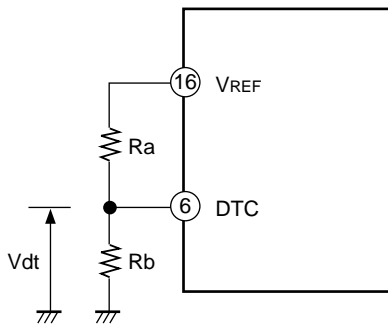

• When not using DTC to set dead time

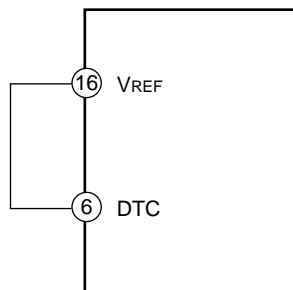

APPLICATION EXAMPLE

1. Step-down scheme

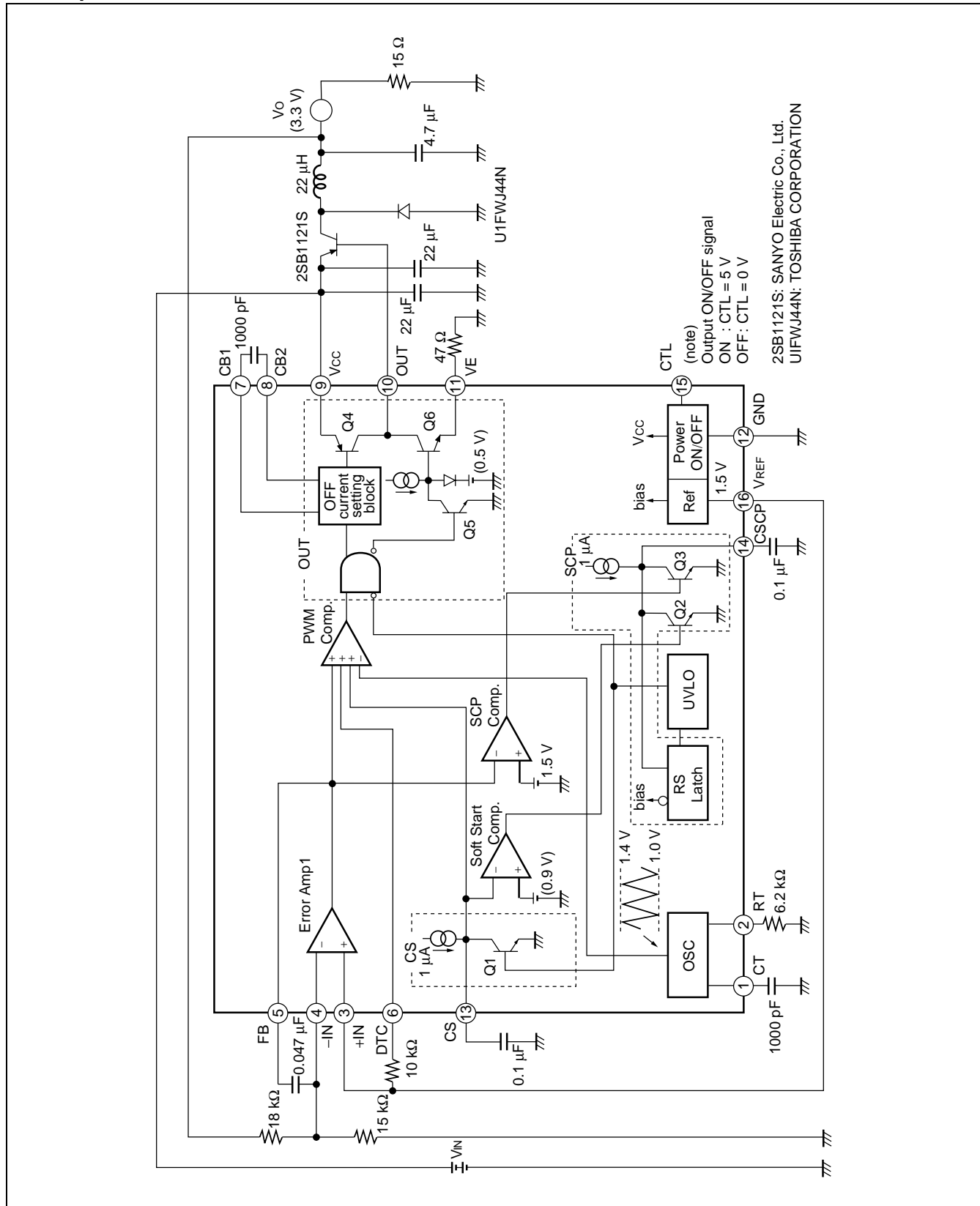

3. Flyback scheme

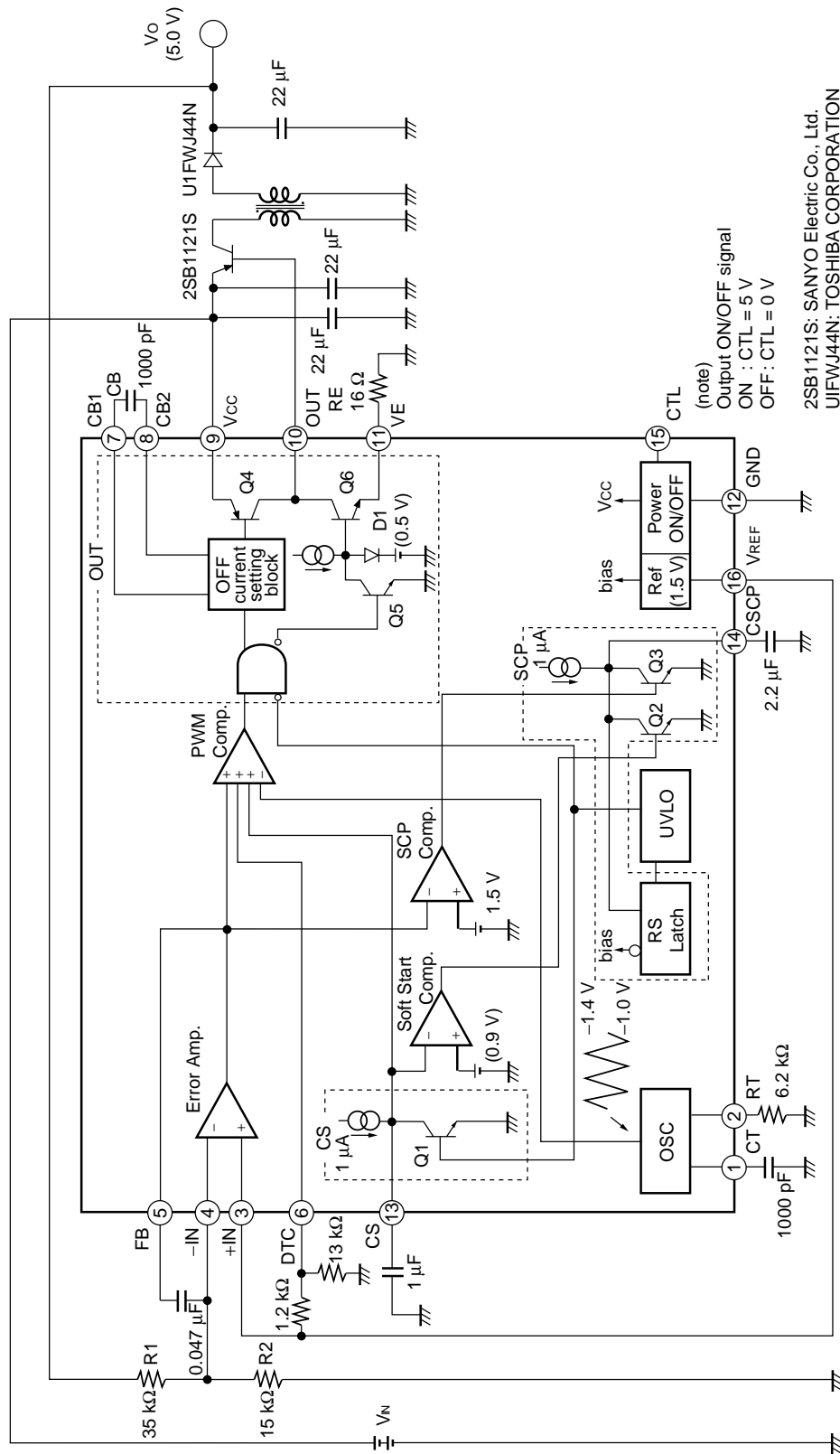

APPLICATION

1. Equivalent series resistance and stability of smoothing capacitor

The equivalent series resistance (ESR) of the smoothing capacitor in the DC/DC converter greatly affects the loop phase characteristic.

A smoothing capacitor with a high ESR improves system stability because the phase is advanced into the high-frequency range of an ideal capacitor (see Fig. 34 and 35). A smoothing capacitor with a low ESR reduces system stability. Use care when using low ESR electrolytic capacitors (OS-CON™) and tantalum capacitors.

Note : OS-CON is the trademark of Sanyo Electric Co.,Ltd.

Figure 33 DC/DC Converter Basic Circuit

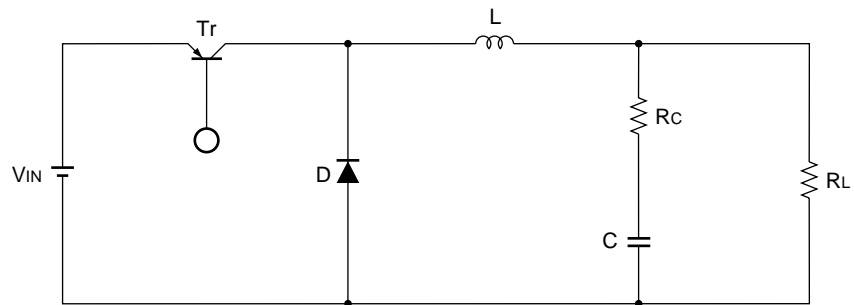

Figure 34 Gain vs. Frequency

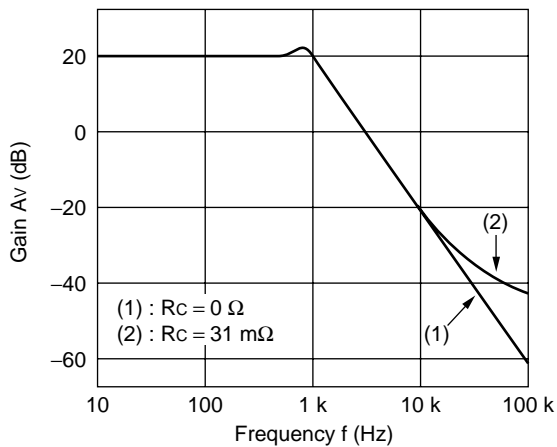
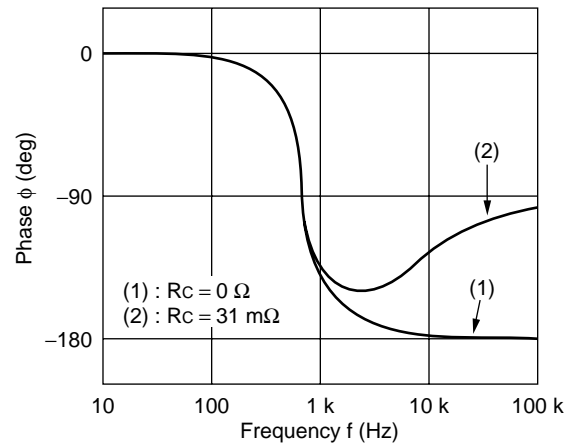

Figure 35 Phase vs. Frequency



Reference data

In an aluminum electrolytic smoothing capacitor ($RC \approx 1.0 \Omega$) is replaced with a low ESR electrolytic capacitor (OS-CON™ : $RC \approx 0.2 \Omega$), the phase margin is reduced by half (see Fig. 37 and 38).

Figure 36 DC/DC Converter A_v vs. ϕ characteristic Test Circuit

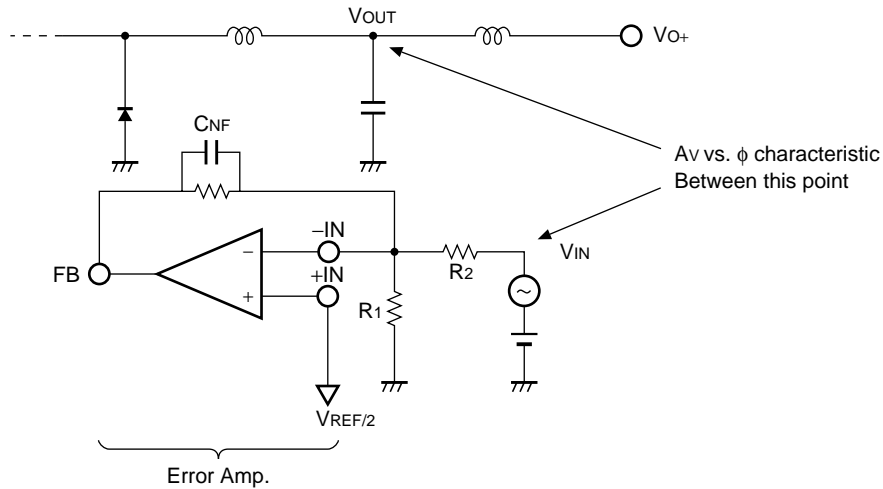

Figure 37 DC/DC Converter +5 V output Gain vs. Phase

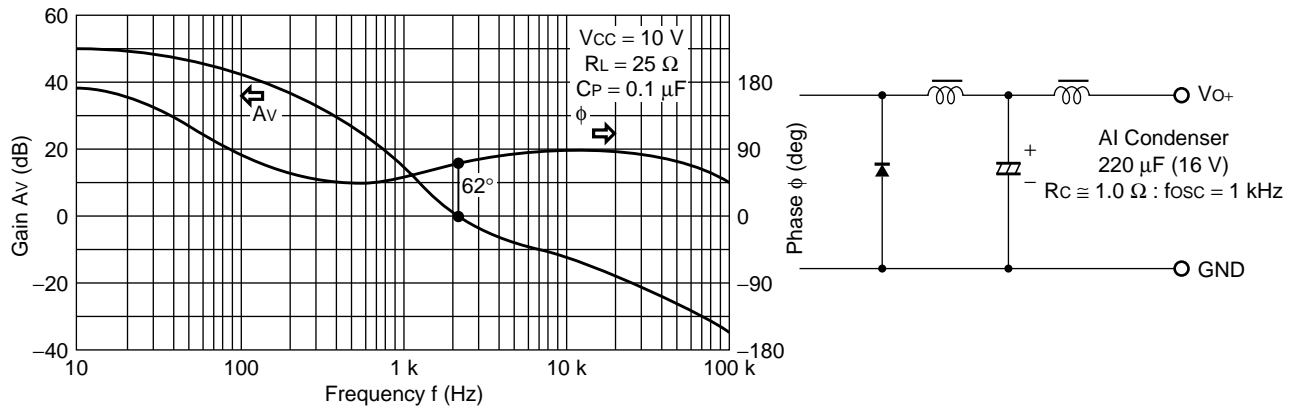
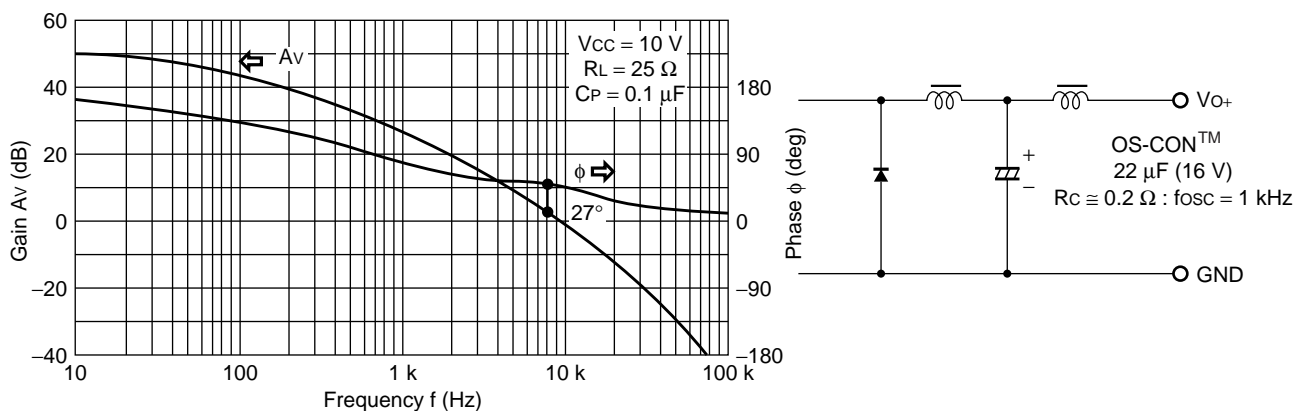

Figure 38 DC/DC Converter +5 V output Gain vs. Phase



■ USAGE PRECAUTIONS

1. Never use setting exceeding maximum rated conditions.

Exceeding maximum rated conditions may cause permanent damage to the LSI.

Also, it is recommended that recommended operating conditions be observed in normal use.

Exceeding recommended operating conditions may adversely affect LSI reliability.

2. Use this device within recommended operating conditions.

Recommended operating conditions are values within which normal LSI operation is warranted.

Standard electrical characteristics are warranted within the range of recommended operating conditions and within the listed conditions for each parameter.

3. Printed circuit board ground lines should be set up with consideration for common impedance.

4. Take appropriate static electricity measures.

- Containers for semiconductor materials should have anti-static protection or be made of conductive material.
- After mounting, printed circuit boards should be stored and shipped in conductive bags or containers.
- Work platforms, tools, and instruments should be properly grounded.
- Working personnel should be grounded with resistance of 250 kΩ to 1 MΩ between body and ground.

■ ORDERING INFORMATION

Part number	Package	Remarks
MB3817PFV	16-pin Plastic SSOP (FPT-16P-M05)	

■ PACKAGE DIMENSION

16-pin Plastic SSOP
(FPT-16P-M05)

* : These dimensions do not include resin protrusion.

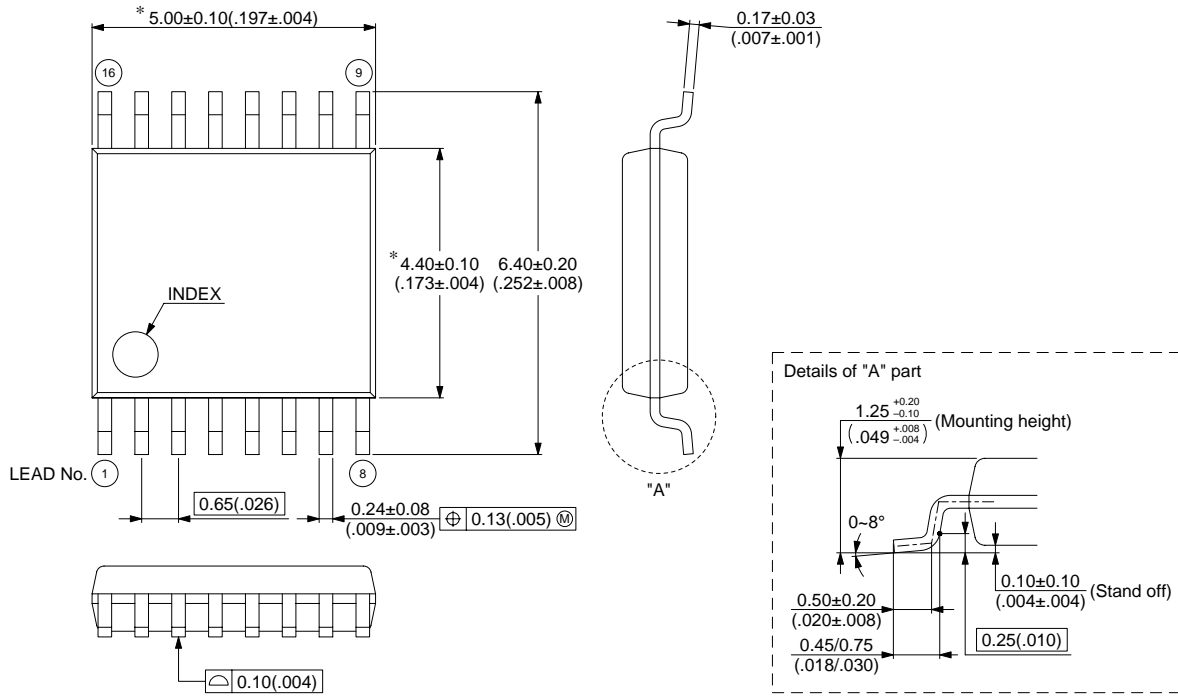

© 1999 FUJITSU LIMITED F16013S-3C-5

Dimensions in mm (inches)

FUJITSU LIMITED

All Rights Reserved.

The contents of this document are subject to change without notice. Customers are advised to consult with FUJITSU sales representatives before ordering.

The information and circuit diagrams in this document are presented as examples of semiconductor device applications, and are not intended to be incorporated in devices for actual use. Also, FUJITSU is unable to assume responsibility for infringement of any patent rights or other rights of third parties arising from the use of this information or circuit diagrams.

The products described in this document are designed, developed and manufactured as contemplated for general use, including without limitation, ordinary industrial use, general office use, personal use, and household use, but are not designed, developed and manufactured as contemplated (1) for use accompanying fatal risks or dangers that, unless extremely high safety is secured, could have a serious effect to the public, and could lead directly to death, personal injury, severe physical damage or other loss (i.e., nuclear reaction control in nuclear facility, aircraft flight control, air traffic control, mass transport control, medical life support system, missile launch control in weapon system), or (2) for use requiring extremely high reliability (i.e., submersible repeater and artificial satellite).

Please note that Fujitsu will not be liable against you and/or any third party for any claims or damages arising in connection with above-mentioned uses of the products.

Any semiconductor devices have an inherent chance of failure. You must protect against injury, damage or loss from such failures by incorporating safety design measures into your facility and equipment such as redundancy, fire protection, and prevention of over-current levels and other abnormal operating conditions.

If any products described in this document represent goods or technologies subject to certain restrictions on export under the Foreign Exchange and Foreign Trade Law of Japan, the prior authorization by Japanese government will be required for export of those products from Japan.

F0103
© FUJITSU LIMITED Printed in Japan