

ASSP

Switching Regulator Controller

MB3778

■ DESCRIPTION

The MB3778 is a dual switching regulator control IC. It has a two-channel basic circuit that controls PWM system switching regulator power. Complete synchronization is achieved by using the same oscillator output wave. This IC can accept any two of the following types of output voltage: step-down, step-up, or voltage inversion (inverting voltage can be output to only one circuit). The MB3778's low power consumption makes it ideal for use in portable equipment.

■ FEATURES

- Wide input voltage range : 3.6 V to 18 V
- Low current consumption : 1.7 mA typ. operation, 10 μ A max. stand-by
- Wide oscillation frequency range:1 kHz to 500 kHz
- Built-in timer latch short-circuit protection circuit
- Built-in under-voltage lockout circuit
- Built-in 2.46 V reference voltage circuit : 1.23 V output can be obtained from R_T terminal
- Variable dead-time provides control over total range
- Built-in stand-by function: power on/off function

■ PACKAGES

16-pin, Plastic DIP

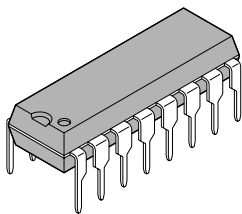

(DIP-16P-M04)

16-pin, Plastic SSOP

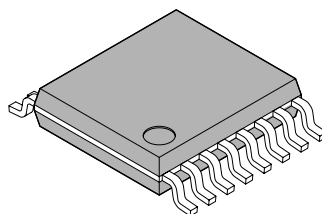

(FPT-16P-M05)

16-pin, Plastic SOP

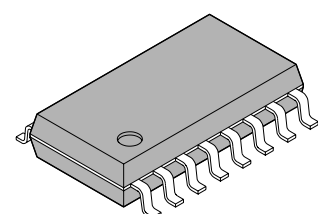

(FPT-16P-M06)

MB3778

■ PIN ASSIGNMENT

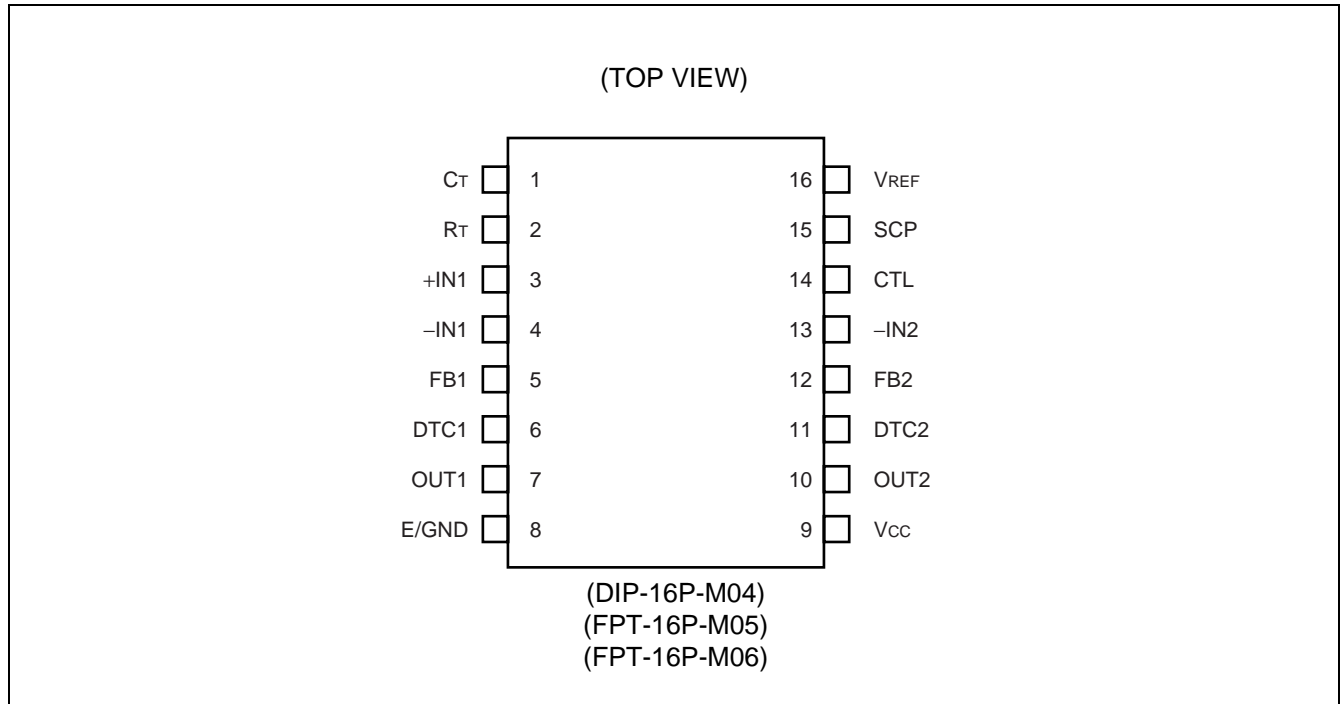

■ PIN DESCRIPTION

No.	Pin	Function
1	C _T	Oscillator timing capacitor terminal (150 pF to 15,000 pF) .
2	R _T	Oscillator timing resistor terminal (5.1 kΩ to 100 kΩ) . V _{REF} × 1/2 voltage is also available at this pin for error amplifier reference input.
3	+IN1	Error amplifier 1 non-inverted input terminal.
4	-IN1	Error amplifier 1 inverted input terminal.
5	FB1	Error amplifier 1 output terminal. A resistor and a capacitor are connected between this terminal and the -IN1 terminal to adjust gain and frequency.
6	DTC1	OUT1 dead-time control terminal. Dead-time control is adjusted by an external resistive divider connected to the V _{REF} pin. A capacitor connected between this terminal and GND enables soft-start operation.
7	OUT1	Open collector output terminal. Output transistor has common ground independent of signal ground. This output can source or sink up to 50 mA.
8	E/GND	Ground terminal.
9	V _{CC}	Power supply terminal (3.6 to 18 V)
10	OUT2	Open collector output terminal. Output transistor has common ground independent of signal ground. This output can source or sink up to 50 mA.
11	DTC2	Sets the dead-time of OUT2. The use of this terminal is the same as that of DTC1.
12	FB2	Error amplifier 2 output terminal. Sets the gain and adjusts the frequency when a resistor and a capacitor are connected between this terminal and the -IN2 terminal. Voltage of V _{REF} × 1/2 voltage is internally connected to the non-inverted input of error amplifier 2. Uses error amplifier 2 for positive voltage output.
13	-IN2	Error amplifier 2 inverted input terminal.
14	CTL	Power control terminal. The IC is set in the stand-by state when this terminal is set "Low." Current consumption is 10 μA or lower in the stand-by state. The input can be driven by TTL or CMOS.
15	SCP	The time constant setting capacitor connection terminal of the timer latch short-circuit protection circuit. Connects a capacitor between this pin and GND. For details, see "How to set time constant for timer latch short-circuit protection circuit".
16	V _{REF}	2.46 V reference voltage output terminal which can be obtained up to 1 mA. This pin is used to set the reference input and idle period of the error amplifiers.

MB3778

■ BLOCK DIAGRAM

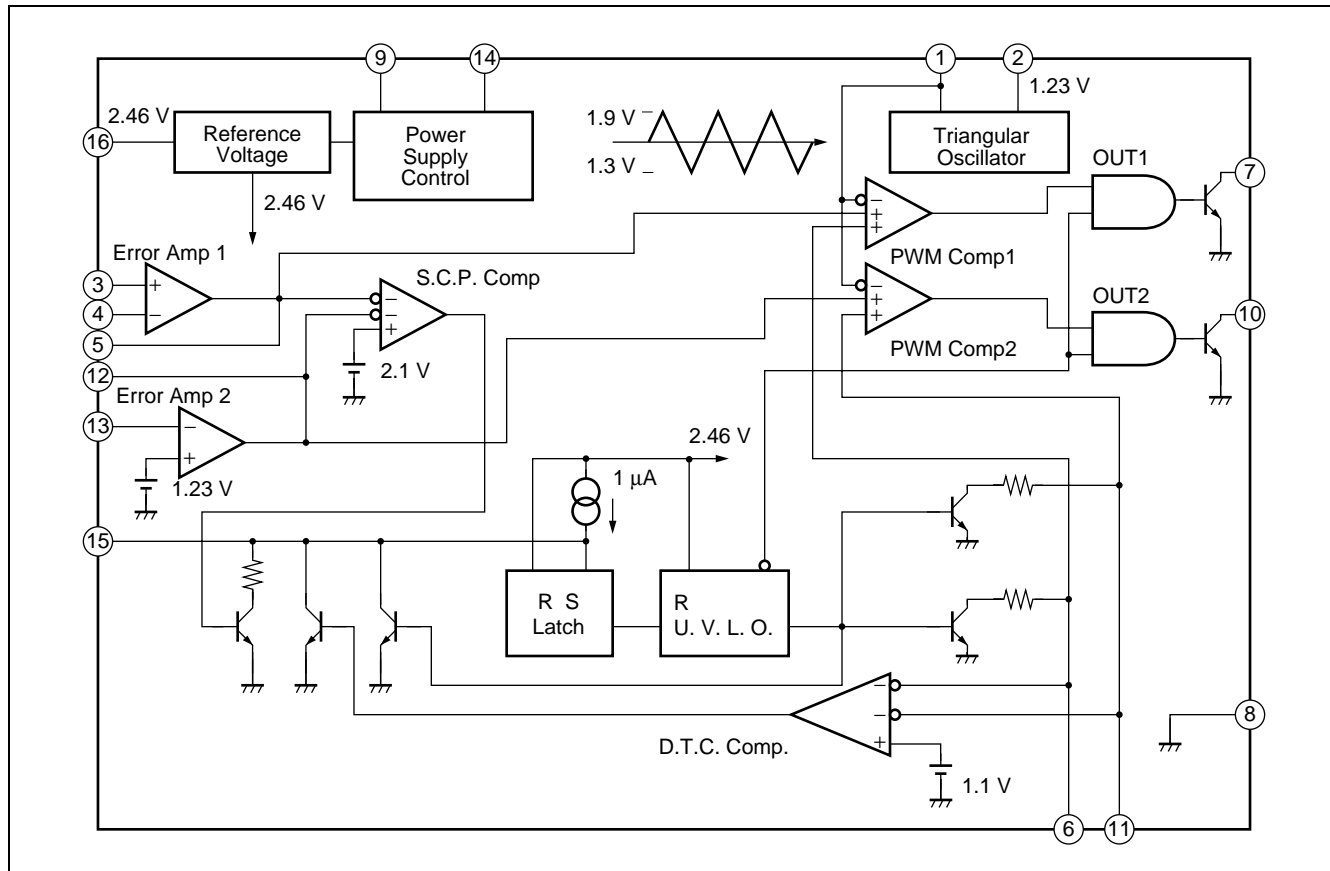

■ OPERATION DESCRIPTION

1. Reference voltage circuit

The reference voltage circuit generates a temperature-compensated reference voltage (≈ 2.46 V) from V_{CC} (pin 9). The reference voltage is used as an operation power supply for internal circuit.

The reference is obtained from the V_{REF} terminal (pin 16).

2. Triangular wave oscillator

Triangular waveforms can be generated at any frequency by connecting a timing capacitor and resistor to the C_T terminal (pin 1) and to the R_T terminal (pin 2).

The amplitude of this waveform is from 1.3 V to 1.9 V. These waveforms are connected to the non-inverting inputs of the PWM comparator and can be output through the C_T terminal.

3. Error amplifiers (Error Amp.)

The error amplifier detects the output voltage of the switching regulator and outputs PWM control signals. The in-phase input voltage range is from 1.05 V to 1.45 V. The reference voltage obtained by dividing the reference voltage output (recommended value: $V_{REF}/2$) or the R_T terminal voltage (1.23 V) is supplied to the non-inverting input. The $V_{REF}/2$ voltage is internally connected to non-inverting input of the other error amplifier.

Any loop gain can be chosen by connecting the feedback resistor and capacitor to the inverting input terminal from the output terminal of the error amplifier. Stable phase compensation is possible.

4. Timer latch short circuit protection circuit

This circuit detects the output levels of each error amplifier. If the output level of one or both of the error amplifiers is 2.1 V or higher, the timer circuit begins charging the externally connected protection enable-capacitor.

If the output level of the error amplifier does not drop below the normal voltage range before the capacitor voltage reaches the transistor base-emitter voltage, V_{BE} (≈ 0.65 V), the latch circuit turns the output drive transistor off and sets the idle period to 100%.

5. Under voltage lock-out circuit

The transition state at power-on or a momentary drops in supply voltage may cause the control IC to malfunction, which may adversely affect or even destroy the system. The under voltage lockout circuit monitors V_{CC} with reference to the internal reference voltage and resets the latch circuit to turn the output drive transistor off. The idle period is set to 100%. It also pulls the SCP terminal (pin 15) "Low".

6. PWM comparator unit

Each PWM comparator has one inverting input and two non-inverting inputs. This voltage-to-pulse-width converter controls the turning on time of the output pulse according to the input voltage.

The PWM comparator turns the output drive transistor on while triangular waveforms from the oscillator are lower than the error amplifier output and the DTC terminal voltage.

7. Output drive transistor

The output drive transistors have open collector outputs with common source supply and common grounds independent of V_{CC} and signal ground. The output drive transistors for switching can sink or source up to 50 mA.

8. Power control unit

The power control terminal (pin 14) controls power on/off modes (the power supply current in stand-by mode is 10 μ A or lower).

MB3778

■ ABSOLUTE MAXIMUM RATINGS (See NOTE)

(Ta = 25 °C)

Parameter	Symbol	Condition	Rating		Unit
			Min.	Max.	
Power Supply Voltage	V _{CC}	—	—	20	V
Error Amp. Input Voltage	V _{IN}	—	-0.3	+10	V
Control Input Voltage	V _{CTL}	—	-0.3	+20	V
Collector Output Voltage	V _{OUT}	—	—	20	V
Collector Output Current	I _{OUT}	—	—	75	mA
Power Dissipation	P _D	Ta ≤ +25 °C (SOP)	—	620* ¹	mW
		Ta ≤ +25 °C (SSOP)	—	444* ²	mW
		Ta ≤ +25 °C (DIP)	—	1000	mW
Operating Temperature	T _{op}	—	-30	+85	°C
Storage Temperature	T _{stg}	—	-55	+125	°C

*1: The packages are mounted on the epoxy board (4 cm × 4 cm)

*2: The packages are mounted on the epoxy board (10 cm × 10 cm)

WARNING: Semiconductor devices can be permanently damaged by application of stress (voltage, current, temperature, etc.) in excess of absolute maximum ratings. Do not exceed these ratings.

■ RECOMMENDED OPERATING CONDITIONS

Parameter	Symbol	Value			Unit
		Min.	Typ.	Max.	
Power Supply Voltage	V _{CC}	3.6	6.0	18	V
Error Amp. Input Voltage	V _{IN}	1.05	—	1.45	V
Control Input Voltage	V _{CTL}	0	—	18	V
Collector Output Voltage	V _{OUT}	—	—	18	V
Collector Output Current	I _{OUT}	0.3	—	50	mA
Timing Capacitor	C _T	150	—	15000	pF
Timing Resistor	R _T	5.1	—	100	kΩ
Oscillator Frequency	f _{osc}	1	—	500	kHz
Operating Temperature	T _{op}	-30	25	85	°C

WARNING: The recommended operating conditions are required in order to ensure the normal operation of the semiconductor device. All of the device's electrical characteristics are warranted when the device is operated within these ranges.

Always use semiconductor devices within their recommended operating condition ranges. Operation outside these ranges may adversely affect reliability and could result in device failure.

No warranty is made with respect to uses, operating conditions, or combinations not represented on the data sheet. Users considering application outside the listed conditions are advised to contact their FUJITSU representatives beforehand.

■ ELECTRICAL CHARACTERISTICS

(Ta = 25 °C, Vcc = 6 V)

Parameter	Symbol	Condition	Value			Unit
			Min.	Typ.	Max.	
Reference Block						
Output Voltage	V _{REF}	I _{OR} = -1 mA	2.41	2.46	2.51	V
Output Temp. Stability	V _{RTC}	Ta = -30 °C to +85 °C	-2	±0.2	2	%
Input Stability	Line	V _{CC} = 3.6 V to 18 V	—	2	10	mV
Load Stability	Load	I _{OR} = -0.1 mA to -1 mA	—	1	7.5	mV
Short Circuit Output Current	I _{OS}	V _{REF} = 2 V	-30	-10	-3	mA
Under Voltage Lockout Protection Block						
Threshold Voltage	V _{TH}	I _{OR} = -0.1 mA	—	2.72	—	V
	V _{TL}	I _{OR} = -0.1 mA	—	2.60	—	V
Hysteresis Width	V _{HYS}	I _{OR} = -0.1 mA	80	120	—	mV
Reset Voltage (V _{CC})	V _R	—	1.5	1.9	—	V
Protection Circuit Block (S.C.P.)						
Input Thresold Voltage	V _{IPC}	—	0.60	0.65	0.70	V
Input Stand by Voltage	V _{STB}	No pull up	—	50	100	mV
Input Latch Voltage	V _{IN}	No pull up	—	50	100	mV
Input Source Current	I _{bpc}	—	-1.4	-1.0	-0.6	μA
Comparator Threshold Voltage	V _{TC}	Pin 5, Pin 12	—	2.1	—	V
Triangular Waveform Oscillator Block						
Oscillator Frequency	f _{OSC}	C _T = 330 pF, R _T = 15 kΩ	160	200	240	kHz
Frequency Deviation	f _{dev}	C _T = 330 pF, R _T = 15 kΩ	—	±5	—	%
Frequency Stability (V _{CC})	f _{dV}	V _{CC} = 3.6 V to 18 V	—	±1	—	%
Frequency Stability (Ta)	f _{dT}	Ta = -30 °C to +85 °C	-4	—	+4	%
Dead-Time Control Block (D.T.C.)						
Input Bias Current	I _{bdt}	—	—	0.2	1	μA
Latch Mode Sink Current	I _{dt}	V _{dt} = 2.5 V	150	500	—	μA
Latch Input Voltage	V _{dt}	I _{dt} = 100 μA	—	—	0.3	V

■ ELECTRICAL CHARACTERISTICS (Continued)

(Ta = 25 °C, Vcc = 6 V)

Parameter	Symbol	Condition	Value			Unit
			Min.	Typ.	Max.	
Error Amp. Block						
Input Offset Voltage	V _{IO}	V _O = 1.6 V	-6	—	6	mV
Input Offset Current	I _{IO}	V _O = 1.6 V	-100	—	100	nA
Input Bias Current	I _B	V _O = 1.6 V	-500	-100	—	nA
Common Mode Input Voltage Range	V _{ICR}	V _{CC} = 3.6 V to 18 V	1.05	—	1.45	V
Voltage Gain	A _V	R _{NF} = 200 kΩ	70	80	—	dB
Frequency Band Width	BW	A _V = 0 dB	—	1.0	—	MHz
Common Mode Rejection Ratio	CMRR	—	60	80	—	dB
Max. Output Voltage Width	V _{OM+}	—	V _{REF} - 0.3	—	—	V
	V _{OM-}	—	—	0.7	0.9	V
Output Sink Current	I _{OM+}	V _O = 1.6	—	1.0	—	mA
Output Source Current	I _{OM-}	V _O = 1.6	—	-60	—	μA
PWM Comparator Block						
Input Threshold Voltage (f _{osc} = 10 kHz)	V _{T100}	Duty Cycle = 100%	—	1.9	2.25	V
	V _{T0}	Duty Cycle = 0%	1.05	1.3	—	V
On duty Cycle	D _{tr}	V _{dt} = V _{REF} /1.45	55	65	75	%
Input Sink Current	I _{IN+}	Pin 5, Pin 12 = 1.6 V	—	1.0	—	mA
Input Source Current	I _{IN-}	Pin 5, Pin 12 = 1.6 V	—	-60	—	μA
Control Block						
Input Off Condition	V _{OFF}	—	—	—	0.7	V
Input On Condition	V _{ON}	—	2.1	—	—	V
Control Terminal Current	I _{CTL}	V _{CTL} = 10 V	—	200	400	μA
Output Block						
Output Leak Current	Leak	V _O = 18 V	—	—	10	μA
Output Saturation Voltage	V _{SAT}	I _O = 50 mA	—	1.1	1.4	V
All Device Block						
Stand-by Current	I _{CCS}	V _{CTL} = 0 V	—	—	10	μA
Average Supply Current	I _{CCa}	V _{CTL} = V _{CC} , No Output Load	—	1.7	2.4	mA

TEST CIRCUIT

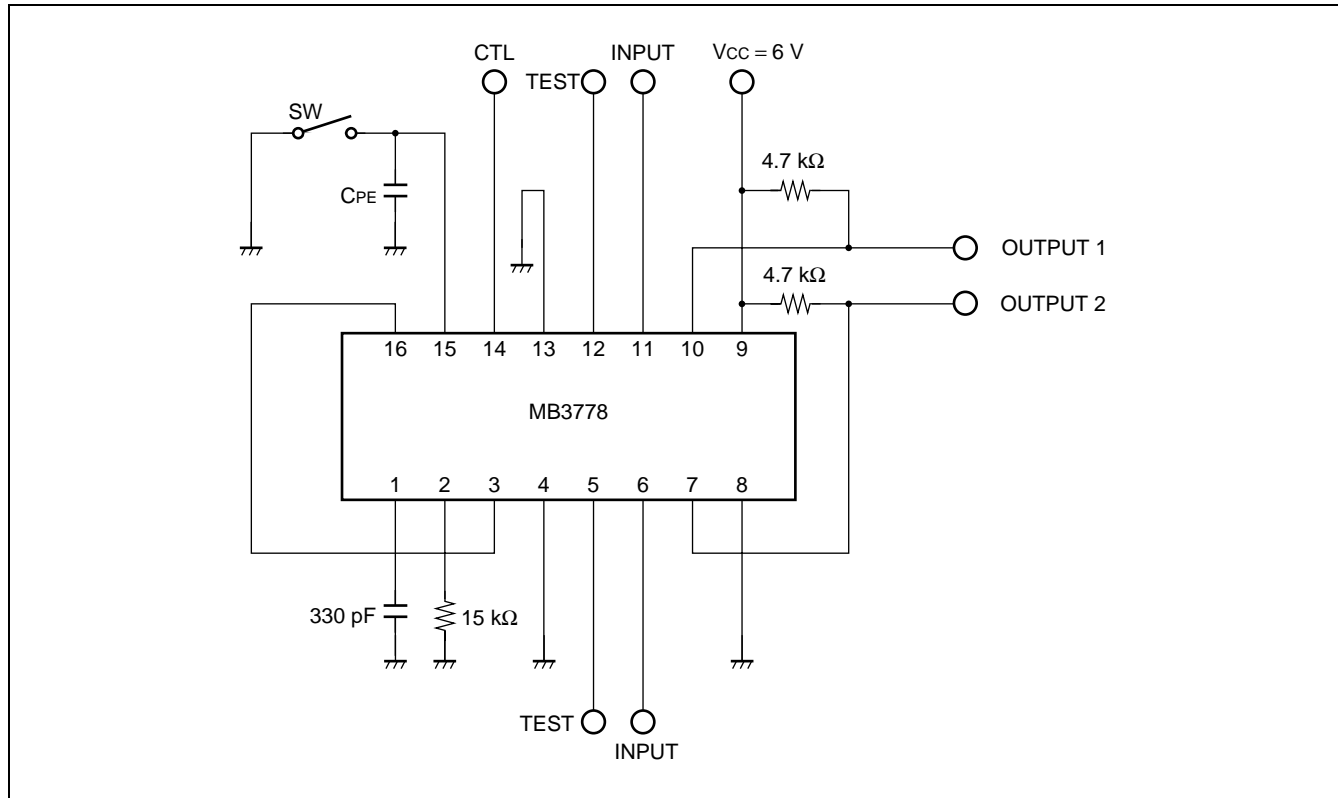

TIMING CHART (Internal Waveform)

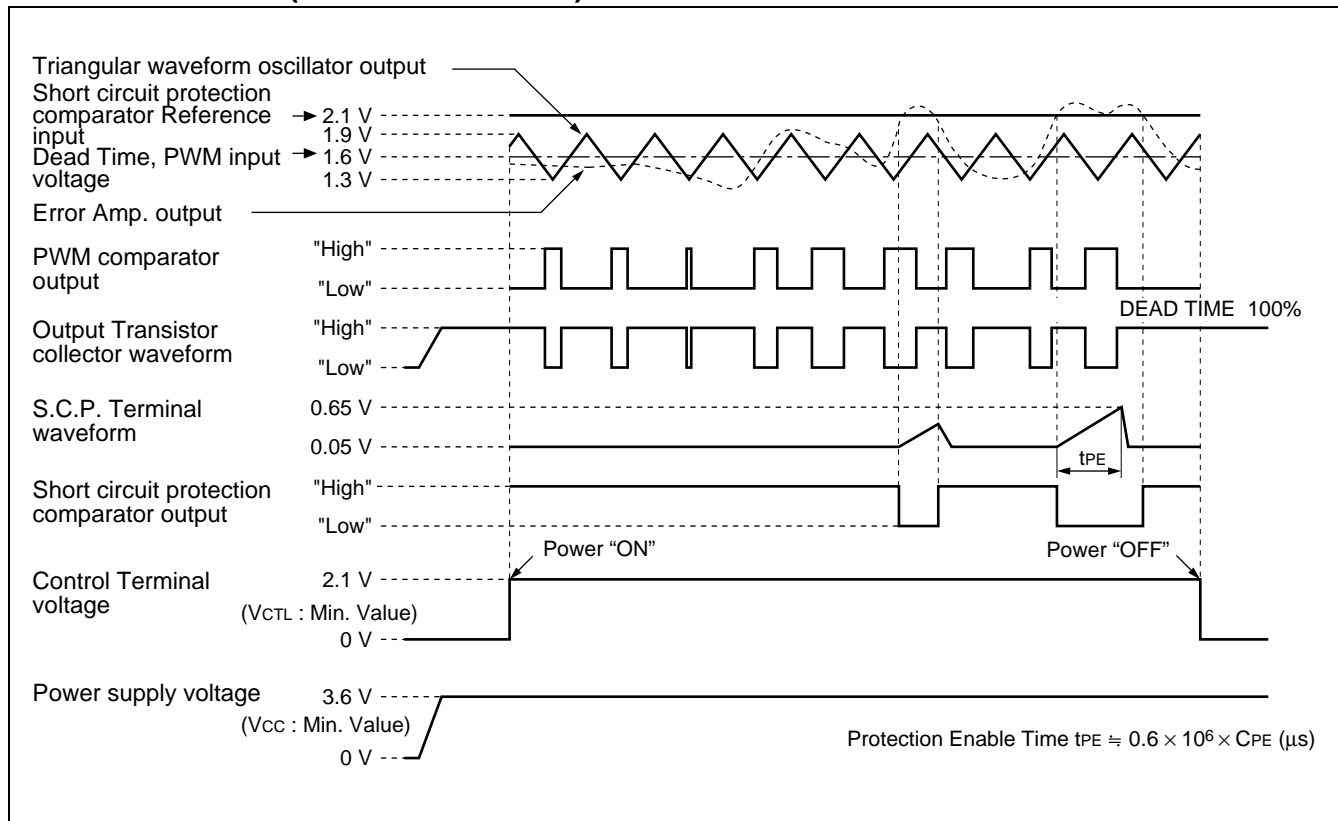

MB3778

APPLICATION CIRCUIT

- Chopper Type Step Down/inverting

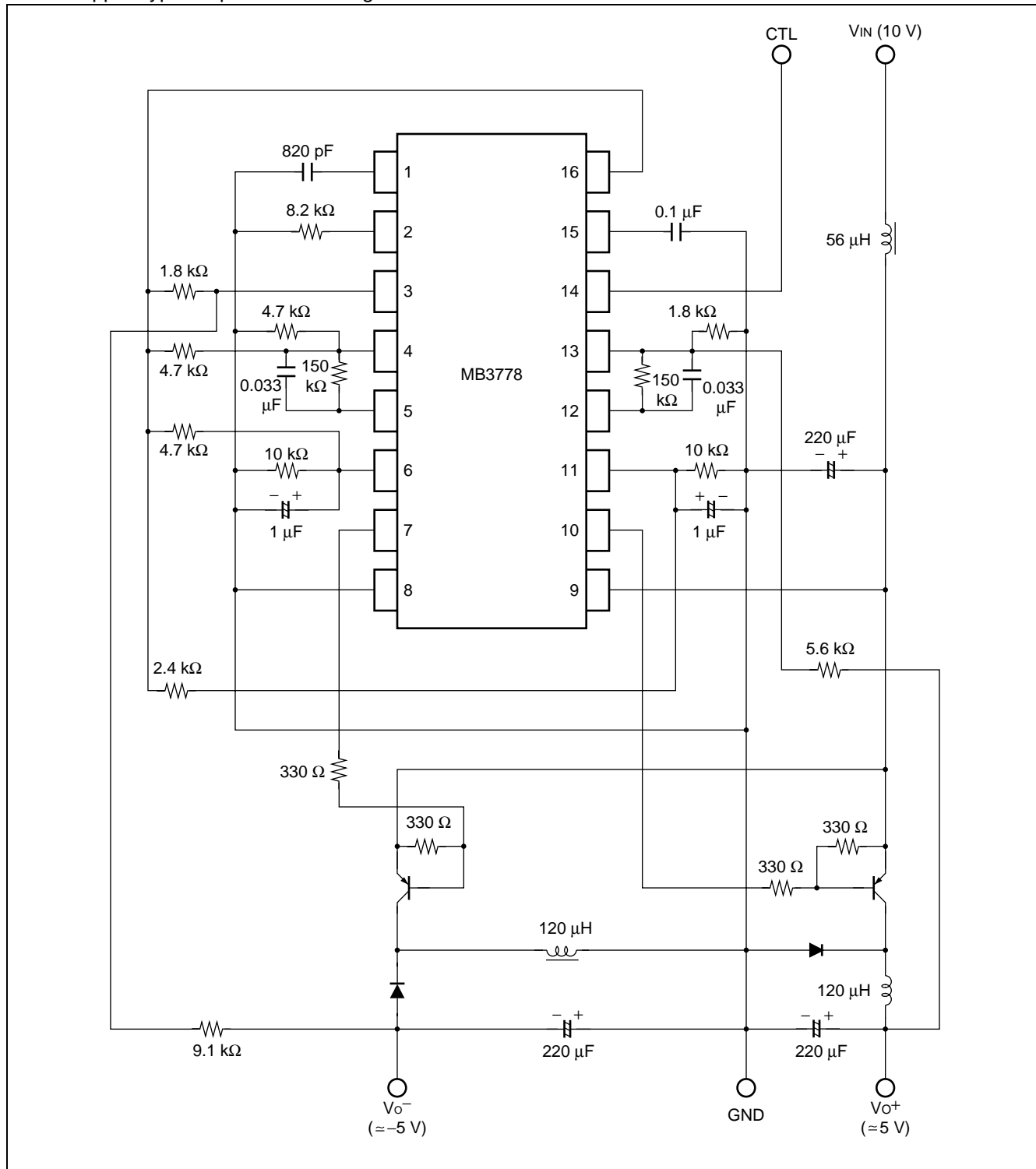

• Chopper Type Step Up/Inverting

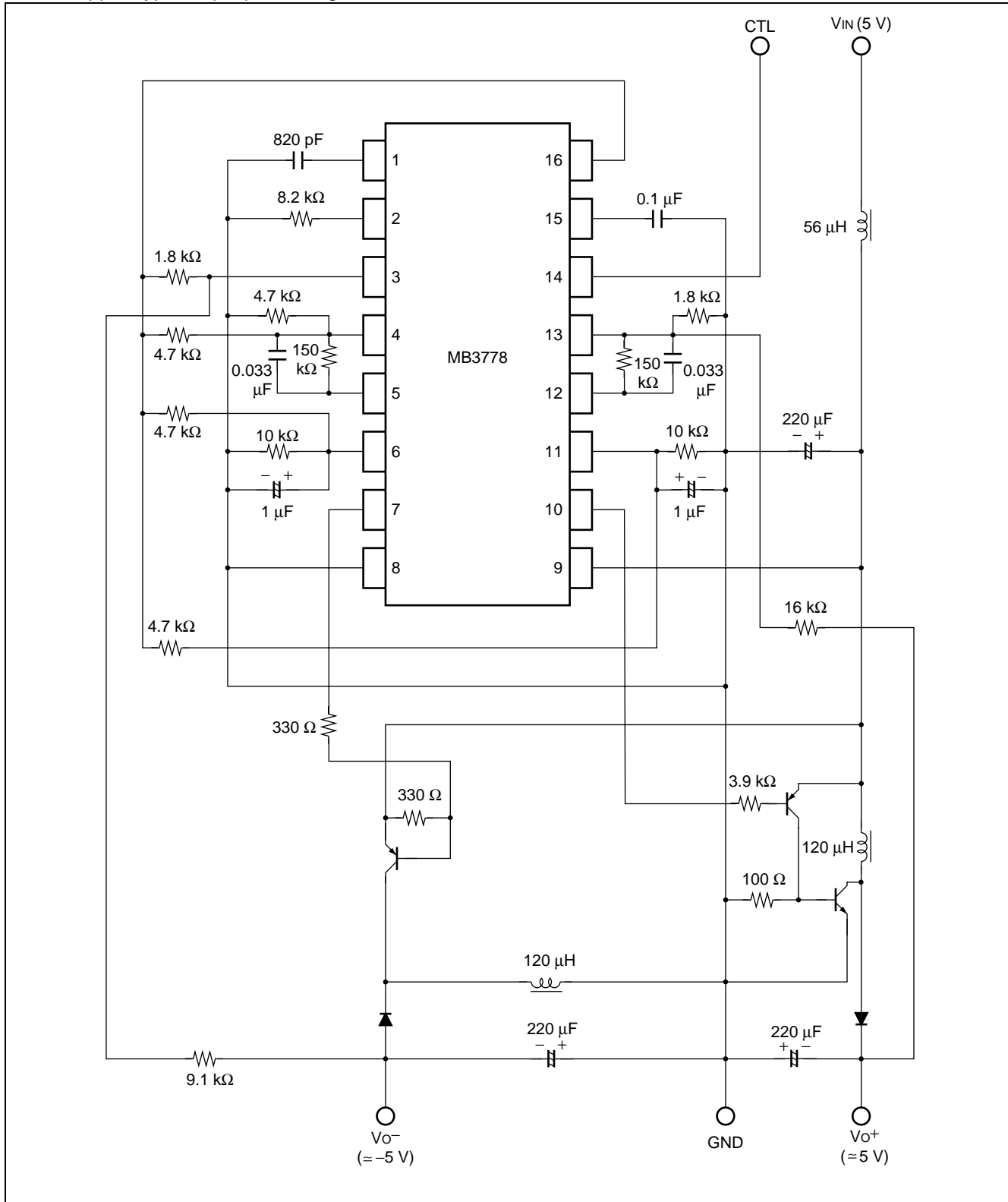

MB3778

- Multi Output Type (Apply Transformer)

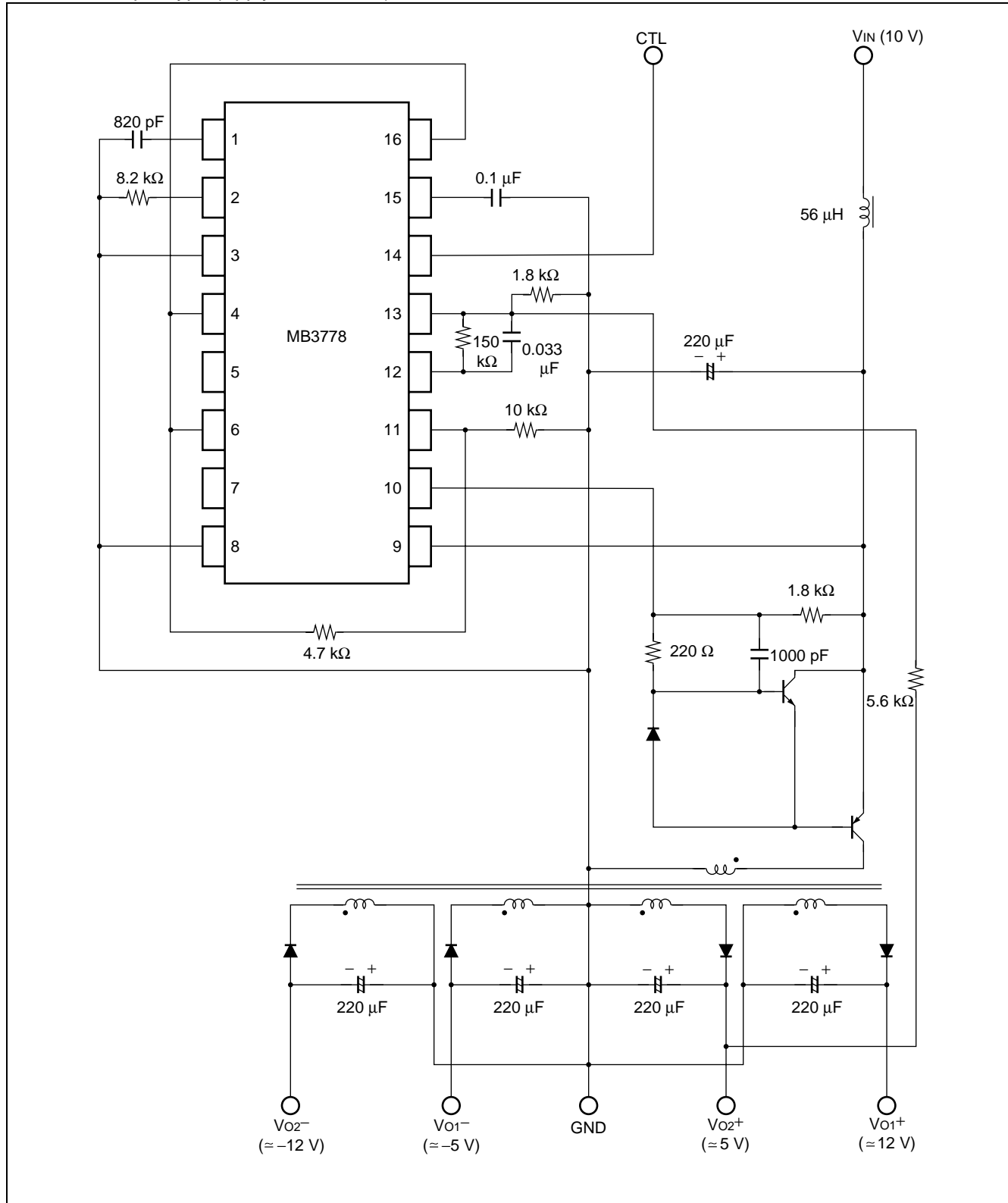

■ HOW TO SET THE OUTPUT VOLTAGE

The output voltage is set using the connections shown in “Connection of error Amp. Output Voltage $V_0 \geq 0$ ” and “Connection of Error Amp. Output Voltage $V_0 < 0$ ”.

The error amplifier power is supplied by the reference voltage circuit as is that of the other internal circuits. The common mode input voltage range is from 1.05 V to 1.45 V.

Set 1.23 V ($V_{REF}/2$) as the reference input voltage that is connected to either inverting or non-inverting input terminals.

• Connection of Error Amp. Output Voltage $V_0 \geq 0$

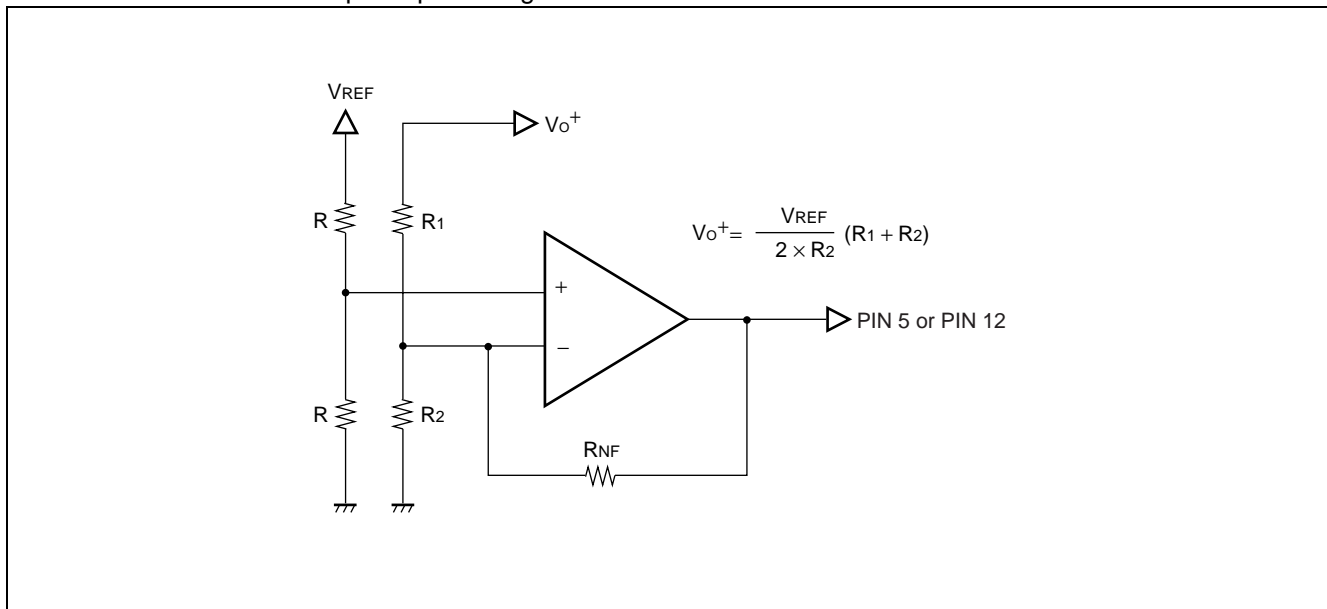

• Connection of Error Amp. Output Voltage $V_0 < 0$

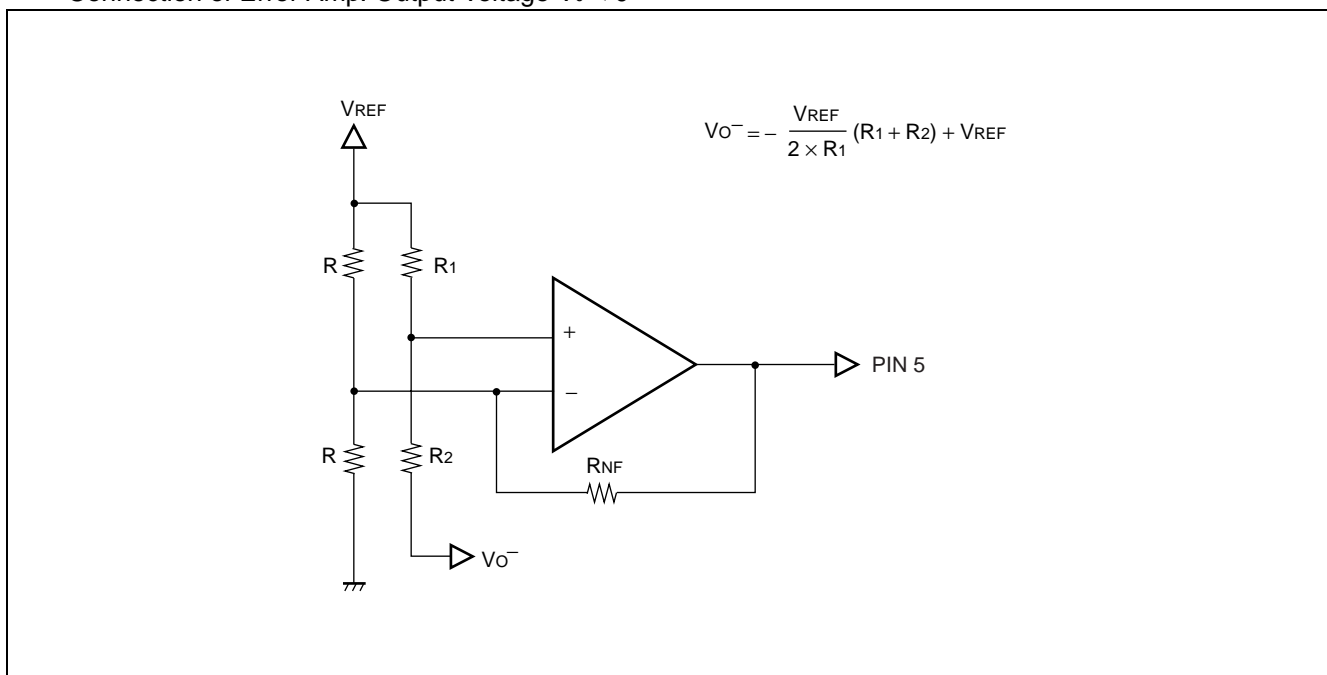

■ HOW TO SET TIME CONSTANT FOR TIMER LATCH SHORT-CIRCUIT PROTECTION CIRCUIT

Below Figure shows the configuration of the protection latch circuit.

Each error amplifier output is connected to the inverting inputs of the short-circuit protection comparator and is always compared with the reference voltage (2.1 V) connected to the non-inverting input.

When the load condition of the switching regulator is stable, the error amplifier has no output fluctuation. Thus, short-circuit protection control is also kept in balance, and the SCP terminal (pin 15) voltage is held at about 50 mV. If the load changes drastically due to a load short-circuit and if the inverting inputs of the short-circuit protection comparator go above 2.1 V, the short-circuit protection comparator output goes "Low" to turn off transistor Q₁. The SCP terminal voltage is discharged, and then the short-circuit protection comparator charges the protection enable capacitor C_{PE} according to the following formula :

$$V_{PE} = 50 \text{ mV} + t_{PE} \times 10^{-6} / C_{PE}$$

$$0.65 = 50 \text{ mV} + t_{PE} \times 10^{-6} / C_{PE}$$

$$C_{PE} = t_{PE} / 0.6 \text{ (}\mu\text{F)}$$

When the protection enable capacitor is charged to about 0.65 V, the protection latch is set to enable the under voltage lockout circuit and the output drive transistor is turned off. The idle period is also set to 100% at the same time.

Once the under voltage lockout circuit is enabled, the protection enable is released; however, the protection latch is not reset if the power is not turned off.

The inverting inputs (pin 6 or 11) of the D.T.C. comparator are compared to the reference voltage (about 1.1 V) connected to the non-inverting input.

To prevent malfunction of the short-circuit protection-circuit when the soft-start operation is done by using the DTC terminal, the D.T.C. comparator outputs a "High" level while the DTC terminal goes up to about 1.1 V, and then closes the SCP terminal by turning transistor Q₂ on.

• Protection Latch Circuit

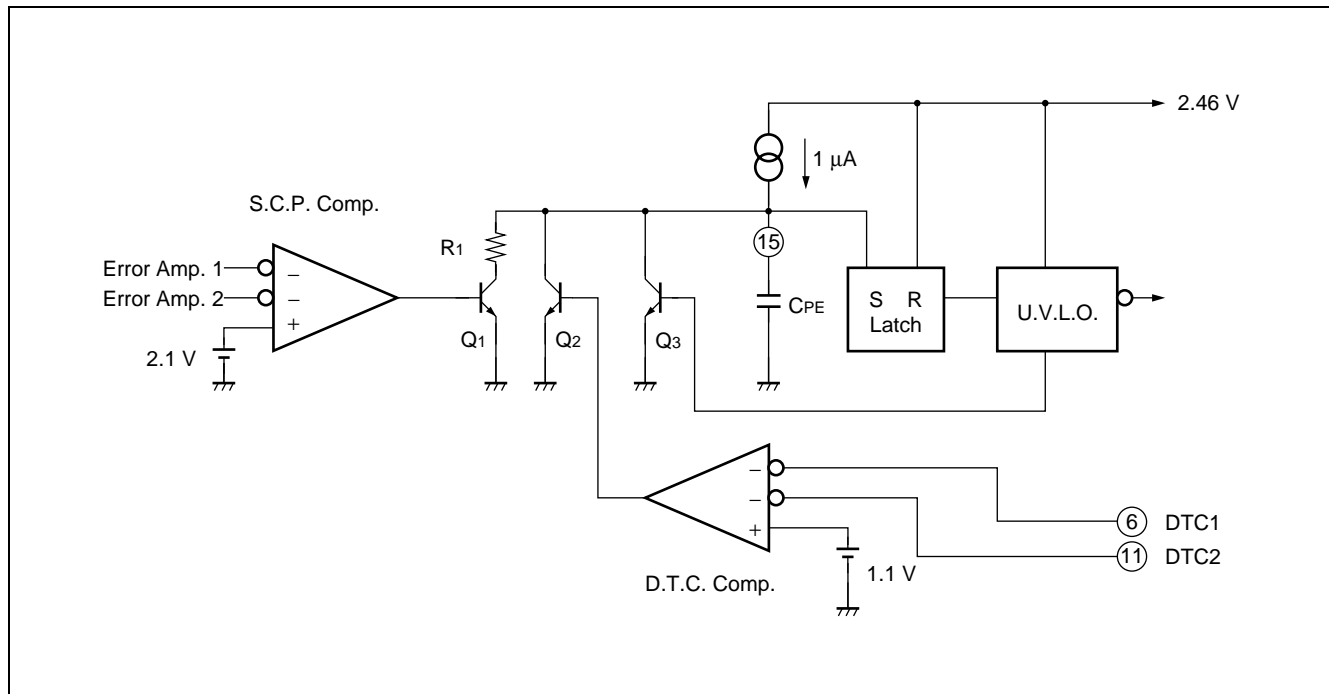

■ SETTING THE IDLE PERIOD

When voltage step-up, fly-back step-up or inverted output are set, the voltage at the FB terminal may go higher than the triangular wave voltage due to load fluctuation, etc. In this case the output transistor will be in full-on state (ON duty 100%). This can be prevented by setting the maximum duty for the output transistor. This is done by setting the DTC1 terminal (pin 6) voltage using resistance division of the V_{REF} voltage as illustrated below.

When the DTC1 terminal voltage is higher than the triangular waveform voltage, the output transistor is turned on. If the triangular waveform amplitude specified by the maximum duty calculation formula is 0.6 V, and the lower voltage limit of the triangular waveform is 1.3 V, the formula would be as follows (other channels are similar) :

$$\text{Duty (ON) max (\%)} \neq (V_{dt} - 1.3 \text{ V}) / 0.6 \text{ V} \times 100, \quad V_{dt} \text{ (V)} = R_b / (R_a + R_b) \times V_{REF}$$

Also, if no output duty setting is required, the voltage should be set greater than the upper limit voltage of the triangular waveform, which is 1.9 V.

- Setting the idle time at DTC1 (DTC2 is similar)

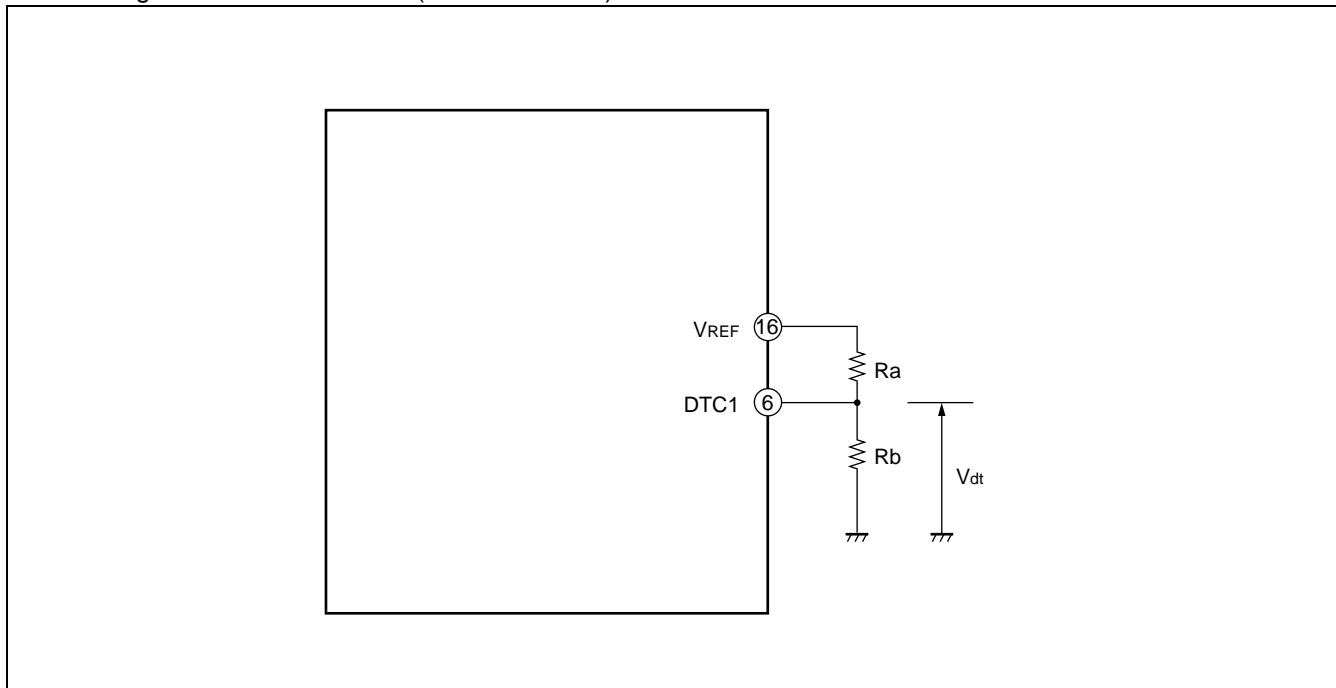

■ SETTING THE SOFT START TIME

When power is switched on, the current begins charging the capacitor (C_{DTC1}) connected the DTC1 terminal (pin 6). The soft start process operates by comparing the soft start setting voltage, which is proportional to the DTC1 terminal voltage, with the triangular waveform, and varying the ON-duty of the OUT terminal (pin 7).

The soft start time until the ON duty reaches 50% is determined by the following equation:

Soft start time (time until output ON duty = 50%) .

$$t_s (s) \doteq - C_{DTC1} \times R_a \times R_b / (R_a + R_b) \times \ln (1 - 1.6 (R_a + R_b) / (2.46 R_b))$$

For example, if $R_a = 4.7 \text{ k}\Omega$ and $R_b = 10 \text{ k}\Omega$, the result is:

$$t_s (s) \doteq 0.1 \times C_{DTC1} (\mu\text{F})$$

- Soft Start on DCT1 terminal (DTC2 is similar)

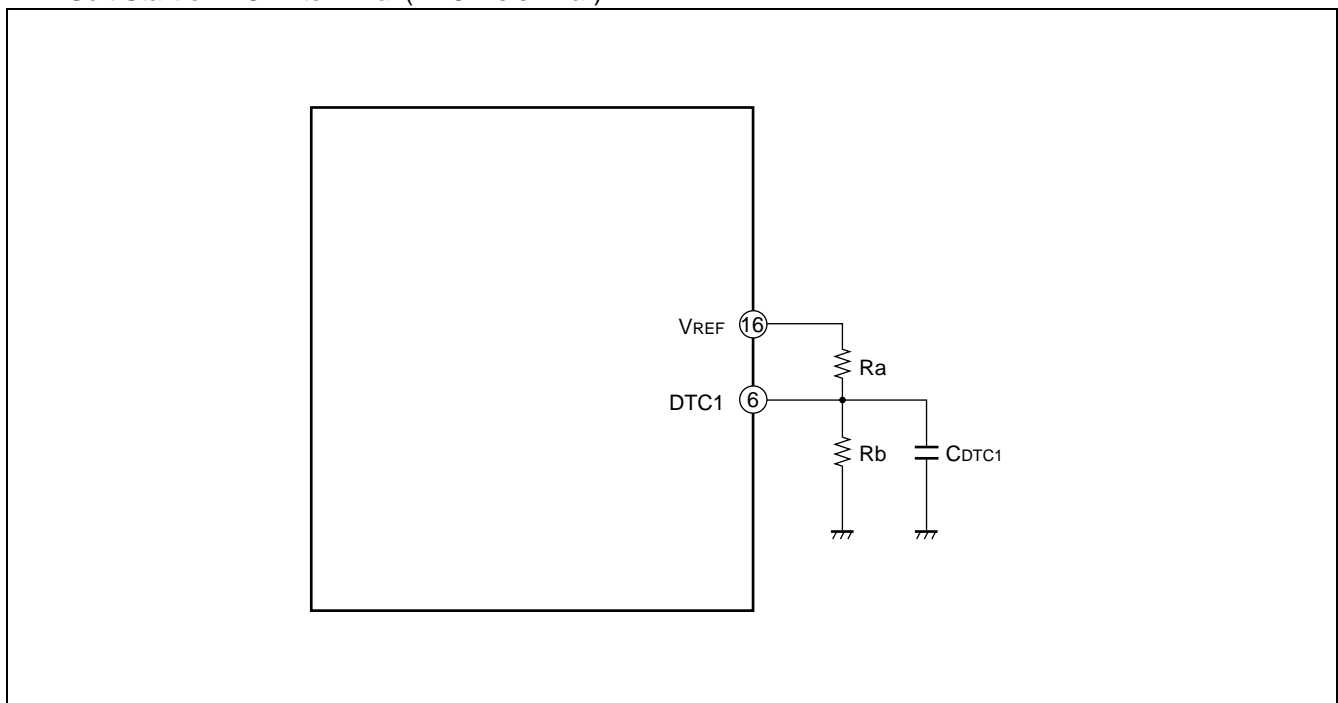

■ USING THE R_T TERMINAL

The triangular waves, as shown in Figure “No V_{REF}/2 connection to external circuits from R_T terminal”, act to set the oscillator frequency by charging and discharging the capacitor connected to the C_T terminal using the current value of the resistor connected to the R_T terminal.

In addition, when voltage level V_{REF}/2 is output to external circuits from the RT terminal, care must be taken in making the external circuit connections to adjust for the fact that I₁ is increased by the value of the current I₂ to the external circuits in determining the oscillator frequency (see Figure “V_{REF}/2 connection to external circuits from R_T terminal”).

• No V_{REF}/2 connection to external circuits from R_T terminal

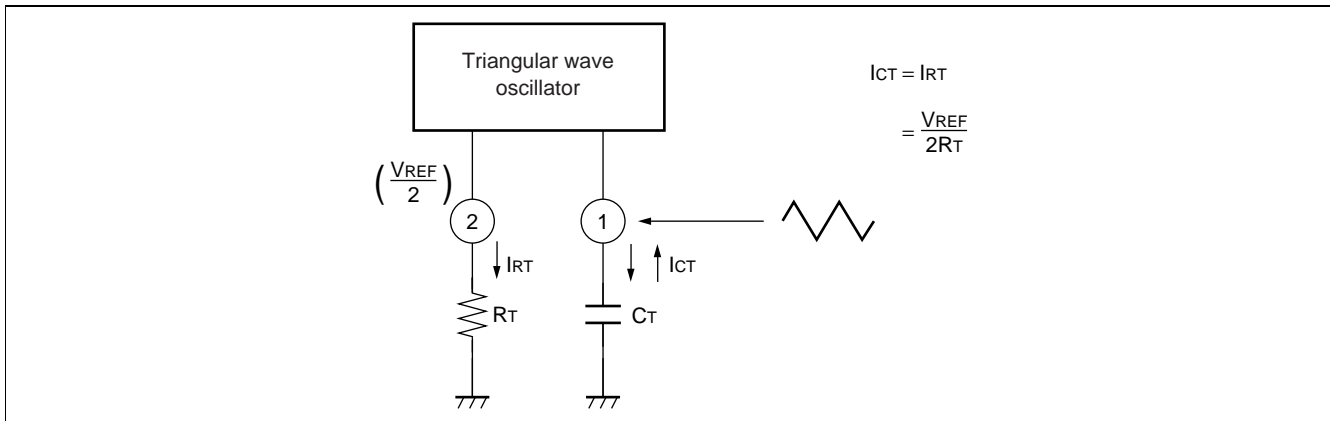

• V_{REF}/2 connection to external circuits from R_T terminal

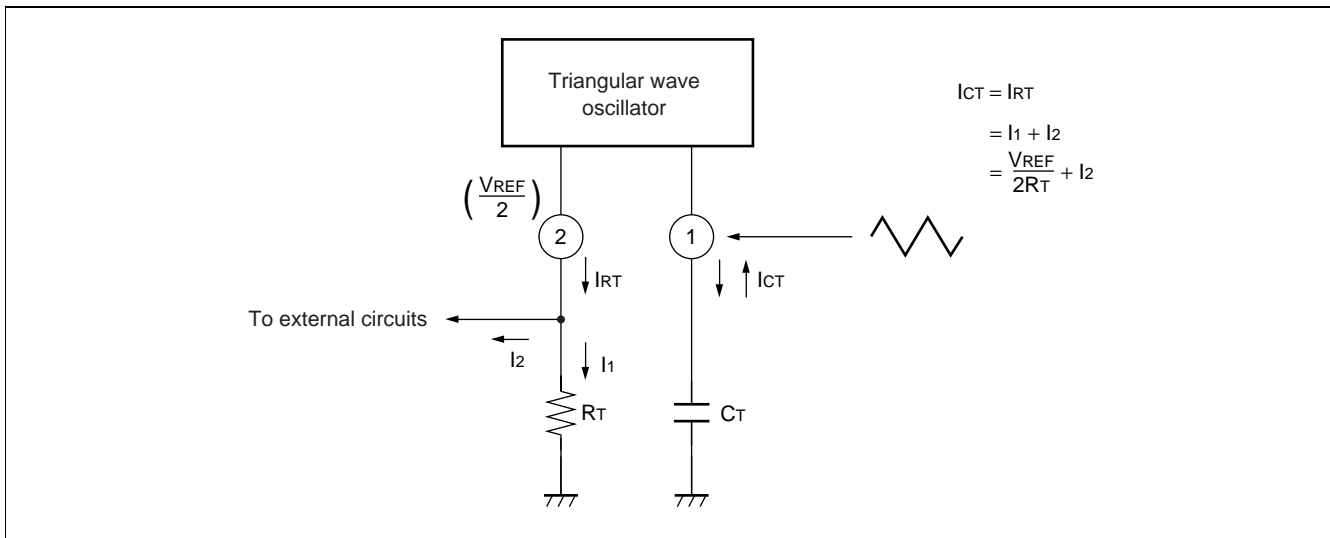

■ SYNCHRONIZATION OF ICs

A fixed condenser and resistor are inserted in the C_T and R_T terminals of IC which becomes a master when synchronizing by using plurality of MB3778. As a result, the slave ICs oscillate automatically. The R_T terminals (pin 2) of the slave ICs are connected to the V_{REF} terminal (pin 16) to disable the charge/discharge circuit for triangular wave oscillation. The C_T terminals of the master and slave ICs are connected together.

• Connection of Master, Slave

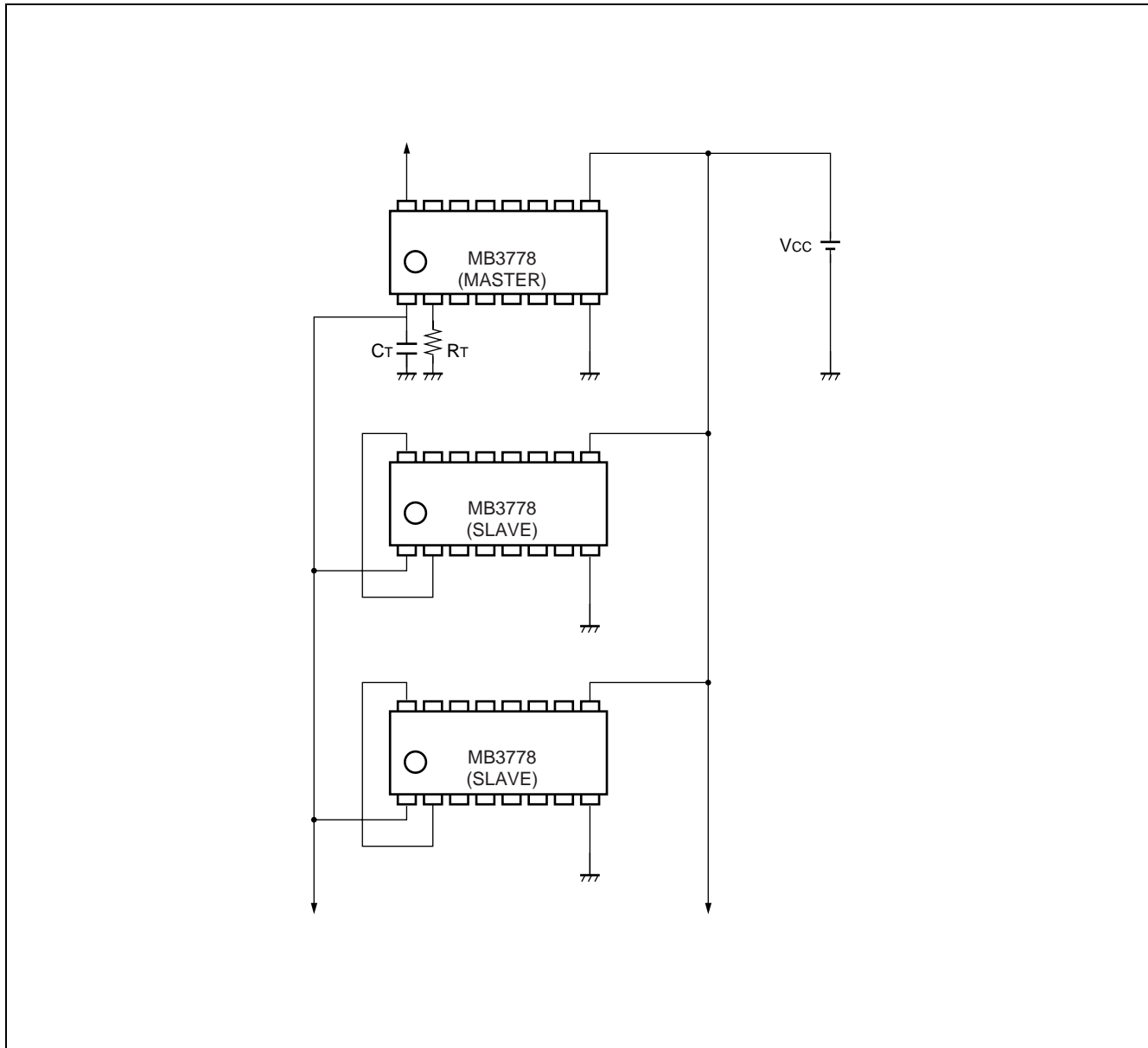

TYPICAL CHARACTERISTICS

Power supply voltage vs. Reference voltage

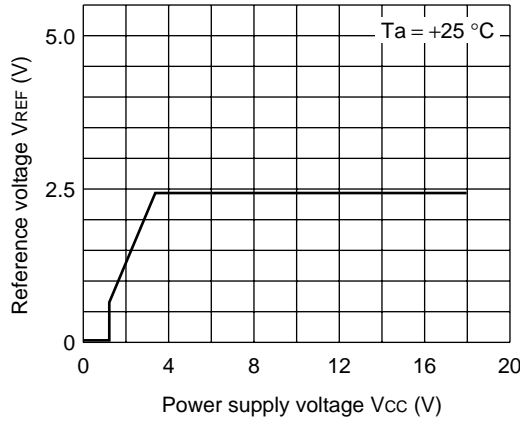

Power supply voltage vs. Average supply current

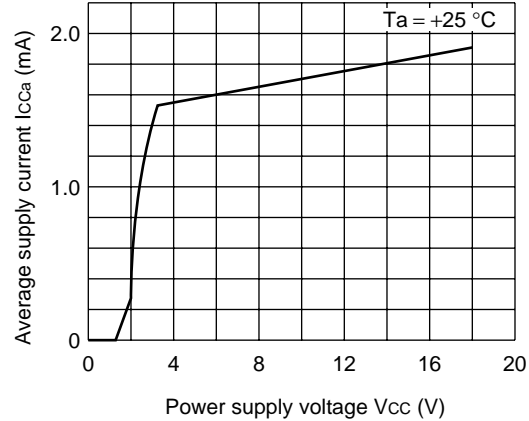

Reference voltage vs. Temperature

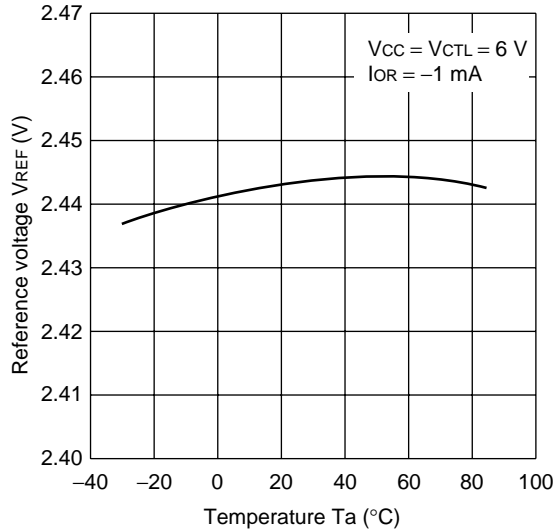

Timing capacitor vs. Triangular waveform Upper/Lower Limit voltage

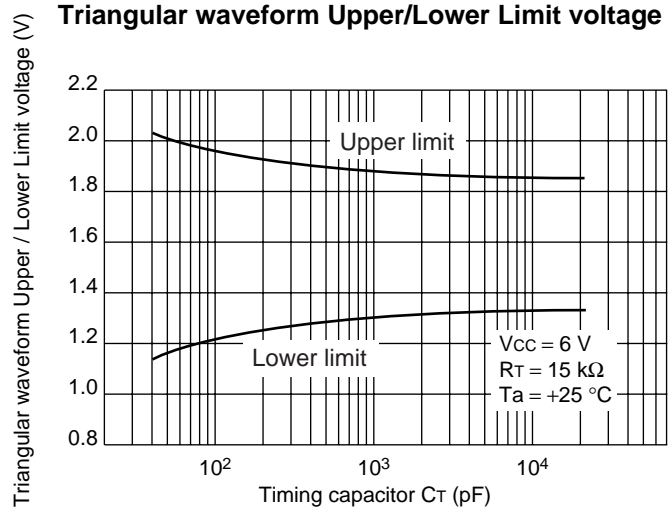

Collector saturation voltage vs. Sink Current

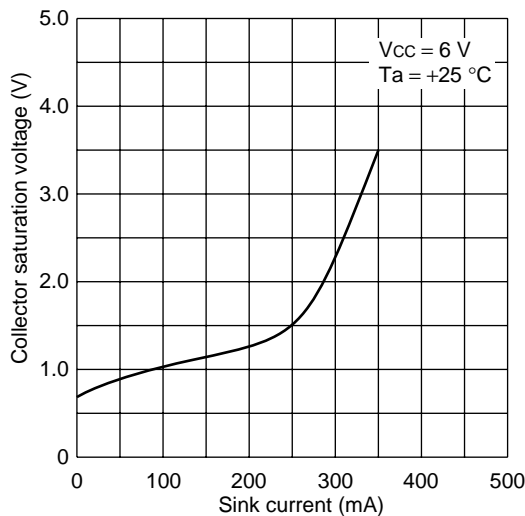

Error Amp. Max. output voltage vs. Frequency

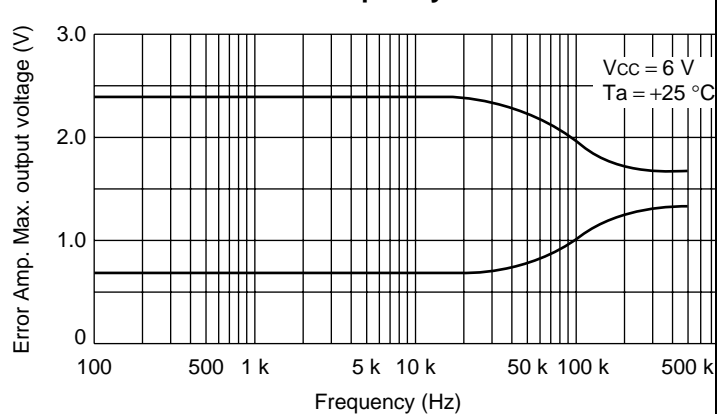

(Continued)

Timing resistor vs. Oscillation frequency

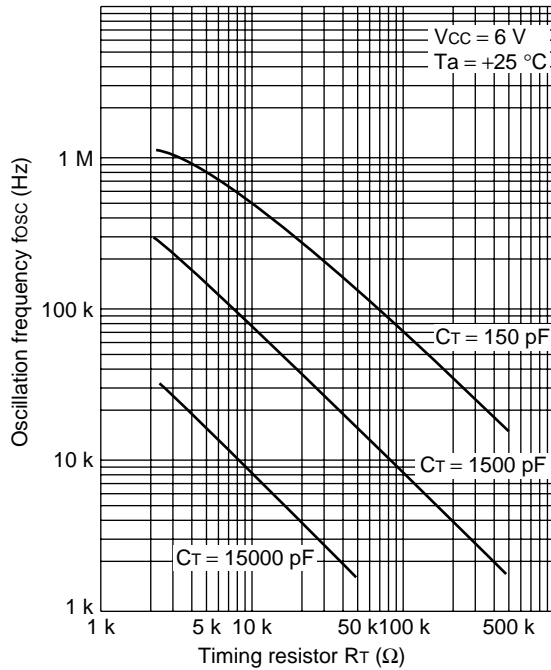

Triangular waveform cycle vs. Timing capacitor

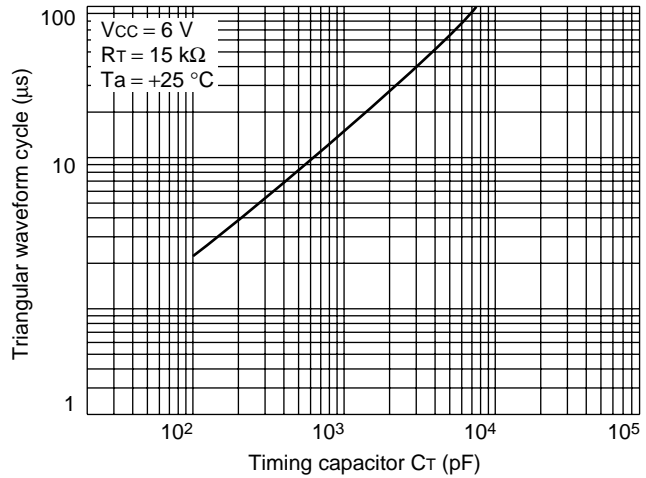

Temperature vs. Frequency stability

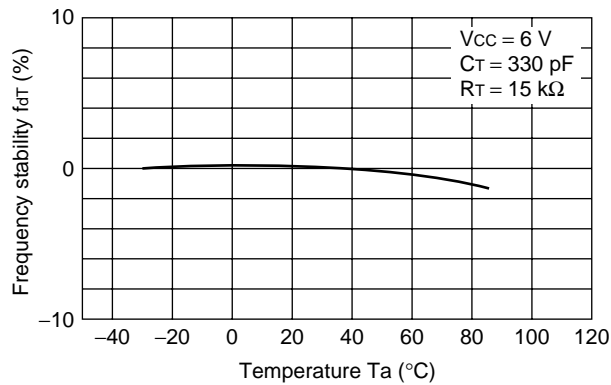

Oscillation frequency vs. Duty

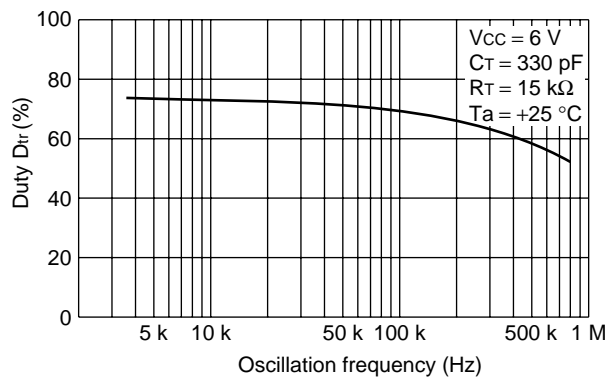

Control voltage vs. Reference voltage

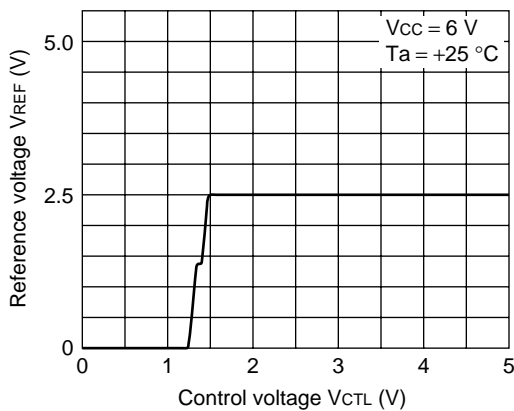

Control input current

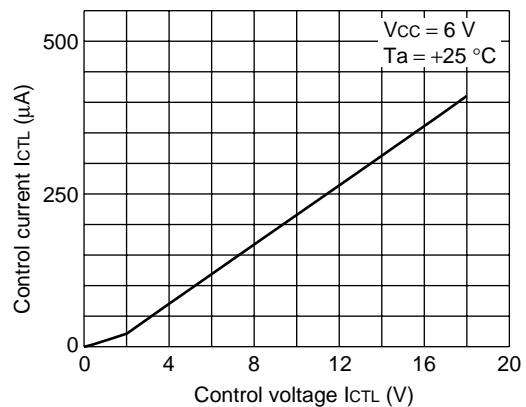

(Continued)

Frequency vs. Gain/Phase

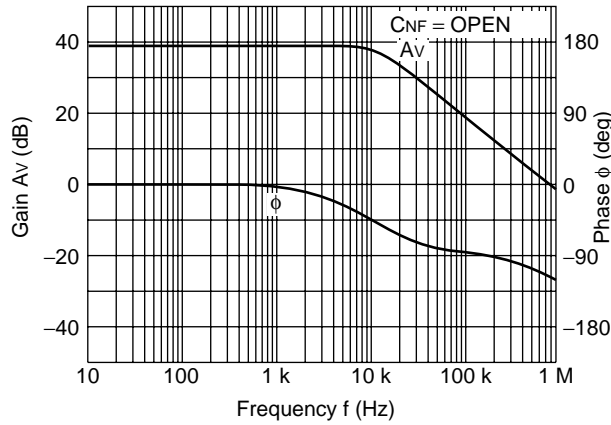

**Frequency vs. Gain/Phase
(Actual Data)**

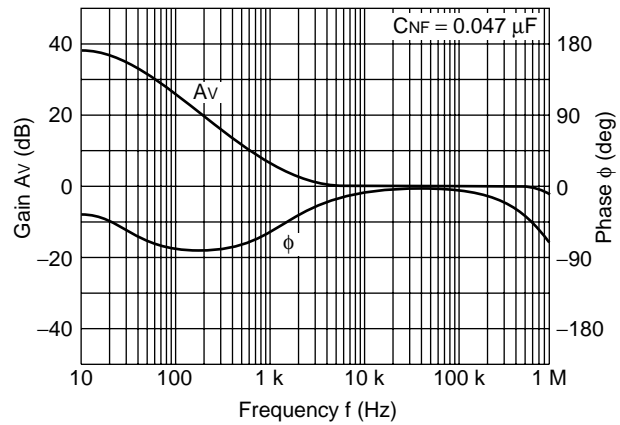

**Frequency vs. Gain/Phase
(Actual Data)**

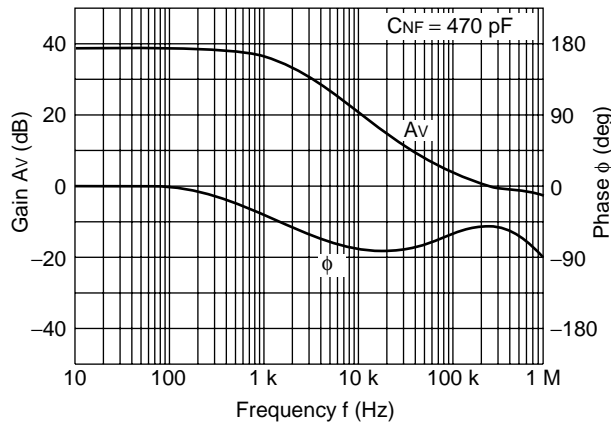

**Frequency vs. Gain/Phase
(Actual Data)**

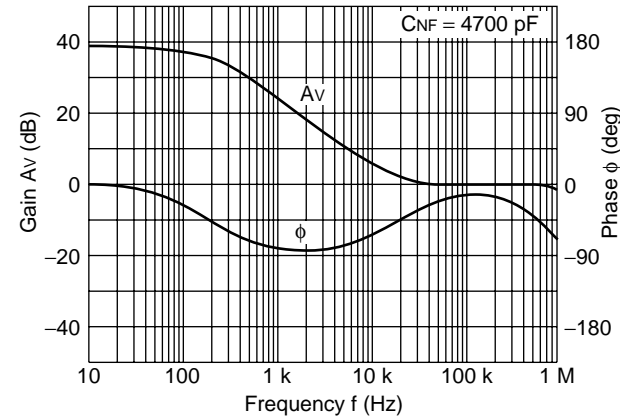

Actual Circuit

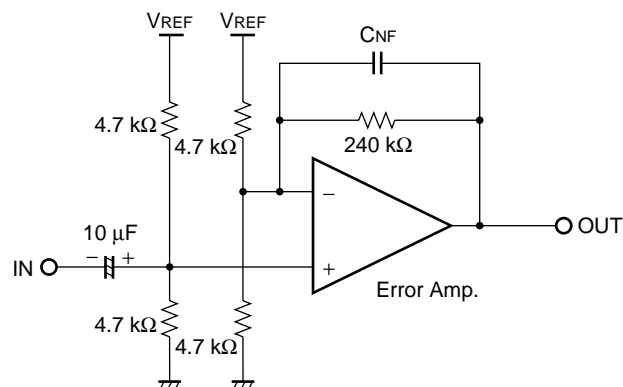

(Continued)

Power Dissipation vs. Ambient Temperature (SOP)

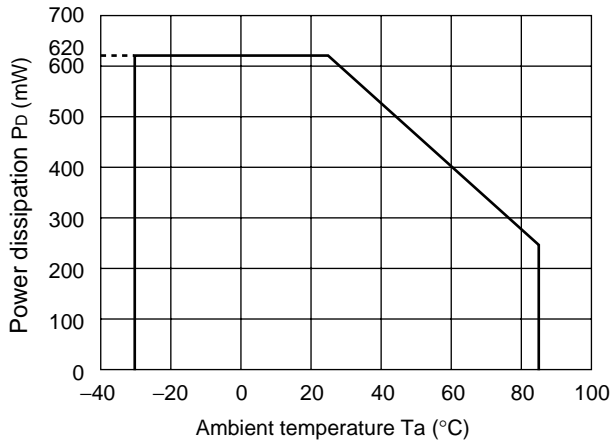

Power Dissipation vs. Ambient Temperature (SSOP)

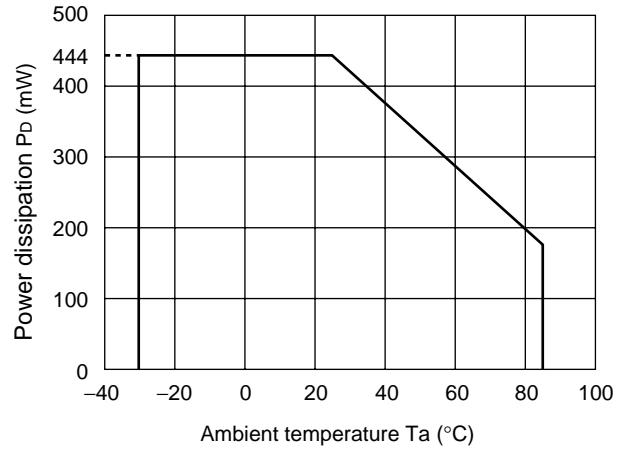

Power Dissipation vs. Ambient Temperature (DIP)

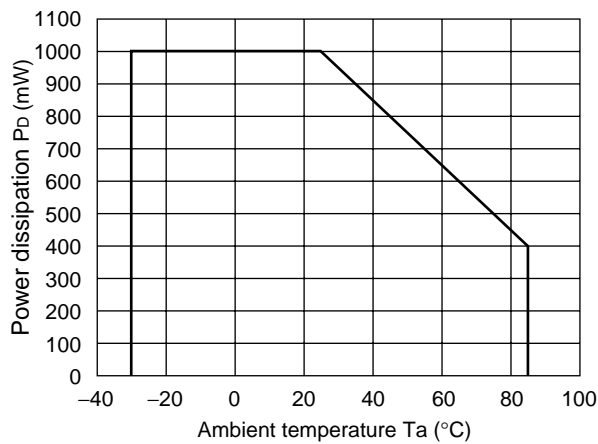

■ APPLICATION

1. Equivalent series resistor and stability of smoothing capacitor

The equivalent series resistor (ESR) of the smoothing capacitor in the DC/DC converter greatly affects the loop phase characteristic.

The stability of the system is improved so that the phase characteristic may advance the phase to the ideal capacitor by ESR in the high frequency region (see "Gain vs. Frequency" and "Phase vs. Frequency").

A smoothing capacitor with a low ESR reduces system stability. Use care when using low ESR electrolytic capacitors (OS CON™) and tantalum capacitors.

Note: OS CON is the trademark of Sanyo Electric Co., Ltd.

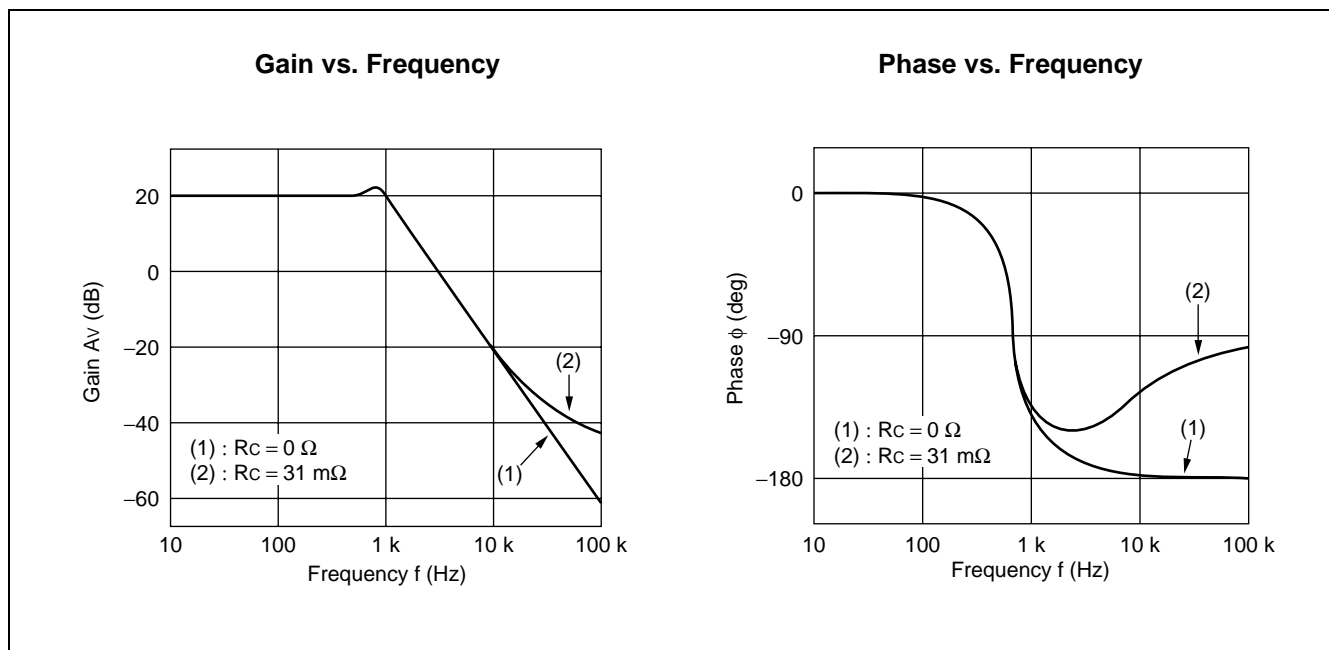
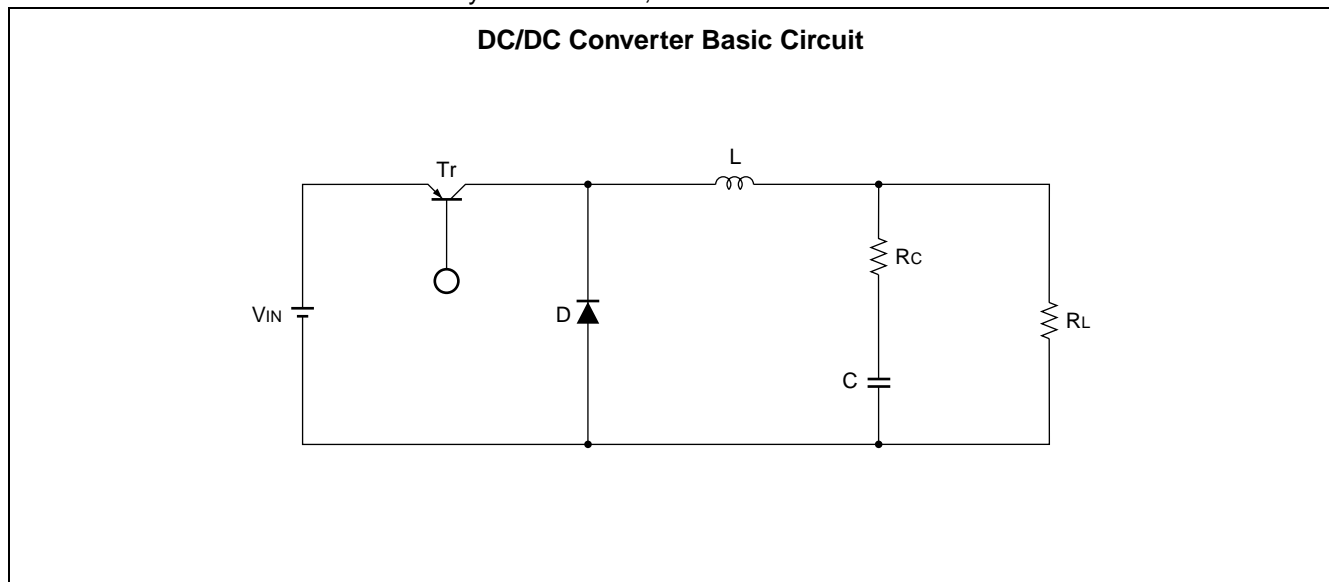

Reference data

If an aluminum electrolytic smoothing capacitor ($RC \cong 1.0 \Omega$) is replaced with a low ESR electrolytic capacitor (OS CON™ : $RC \cong 0.2 \Omega$), the phase margin is reduced by half (see Fig. 37 and 38).

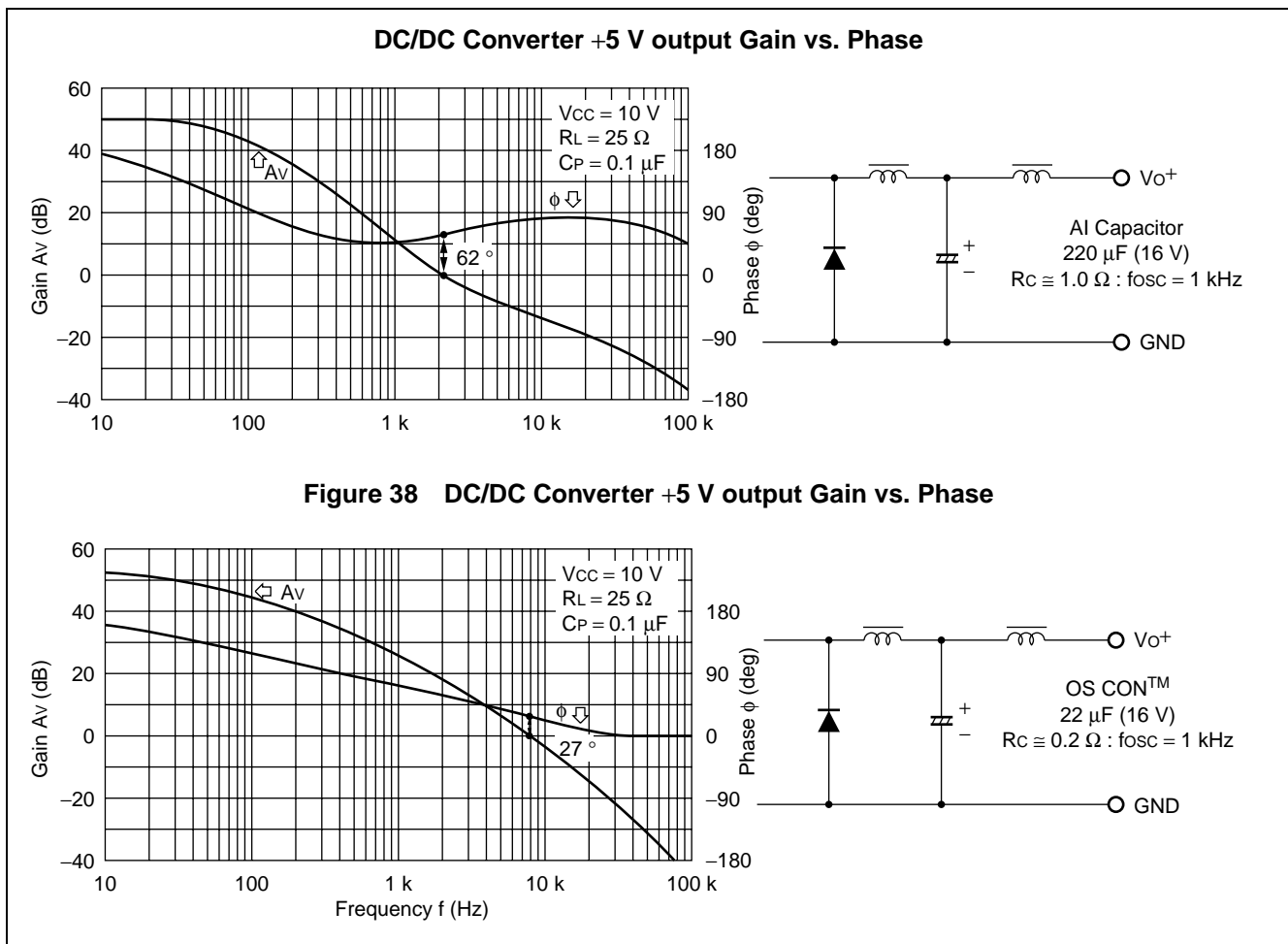
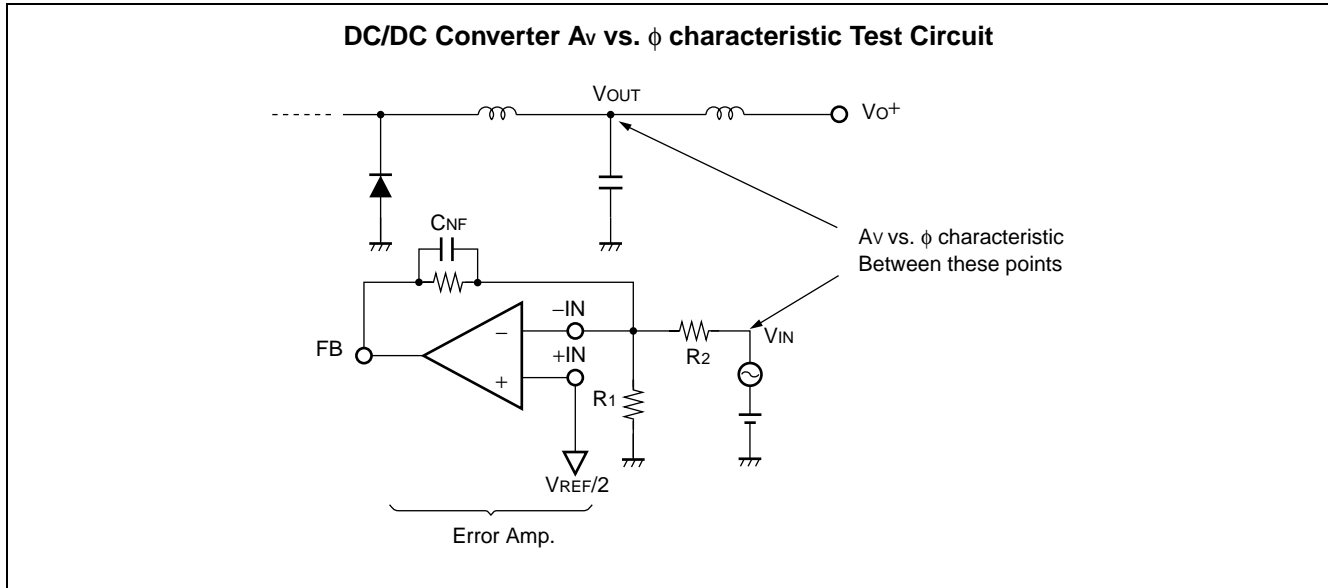

■ ORDERING INFORMATION

Part number	Package	Remarks
MB3778P	16-pin Plastic DIP (DIP-16P-M04)	
MB3778PFV	16-pin Plastic SSOP (FPT-16P-M05)	
MB3778PF	16-pin Plastic SOP (FPT-16P-M06)	

MB3778

■ PACKAGES DIMENSION

16-pin, Plastic DIP
(DIP-16P-M04)

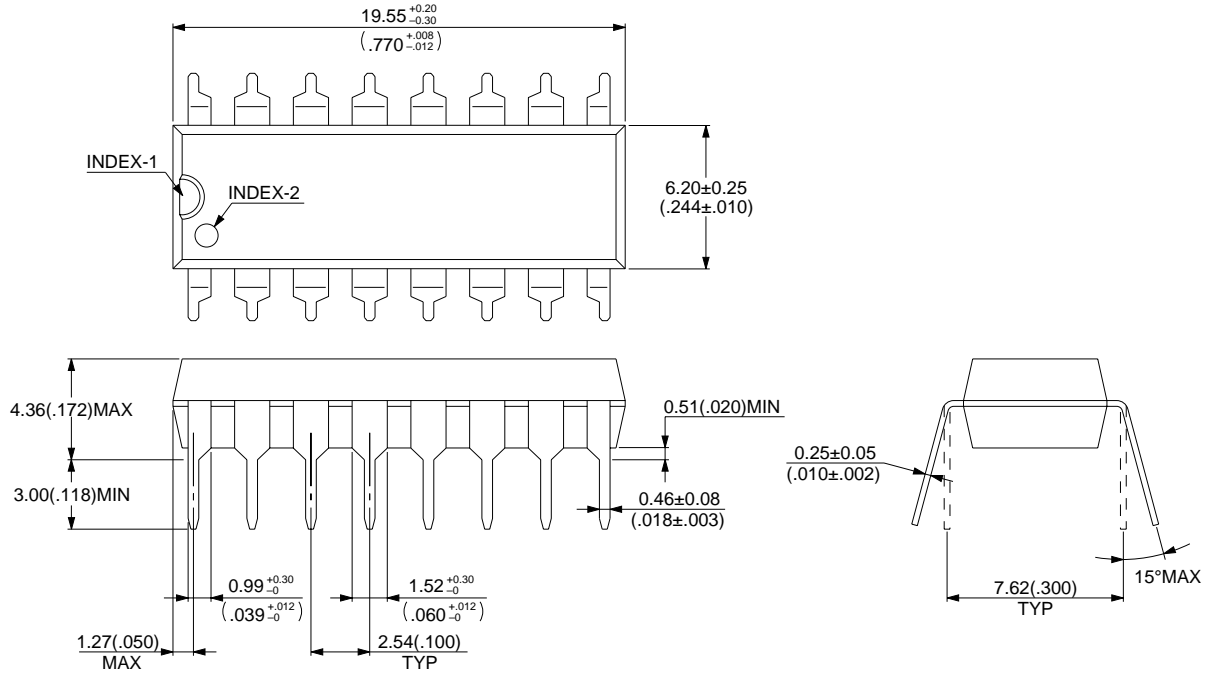

© 1994 FUJITSU LIMITED D16033S-2C-3

Dimensions in mm (inches)

(Continued)

(Continued)

16-pin, Plastic SSOP
(FPT-16P-M05)

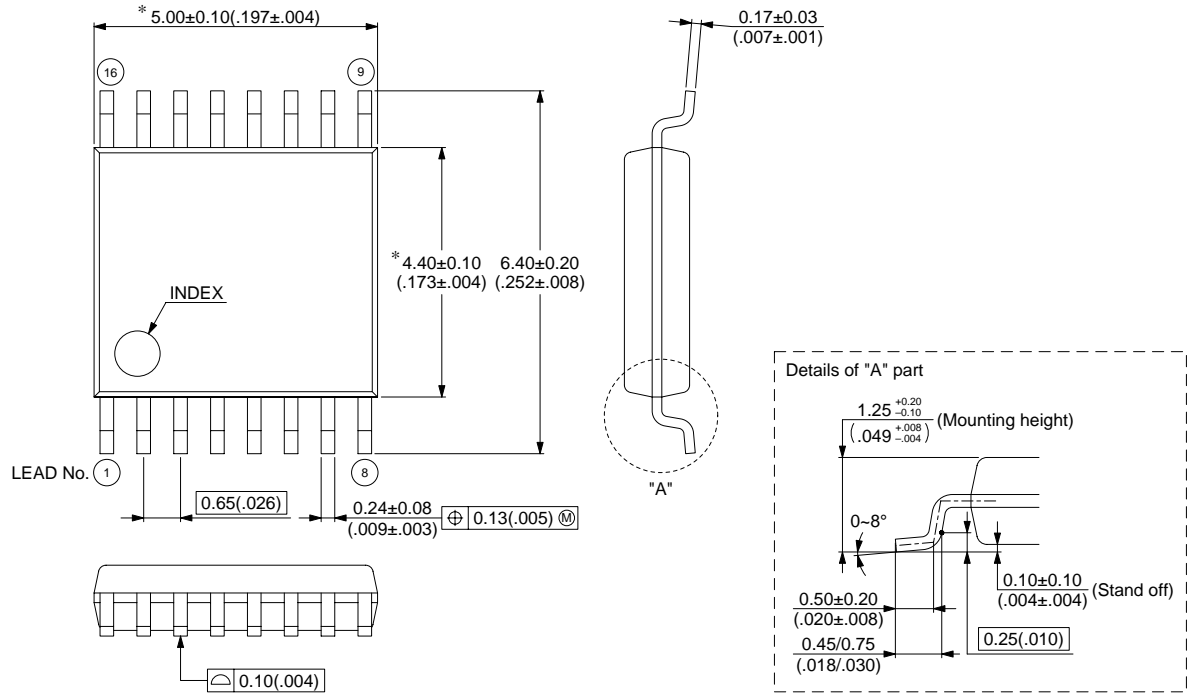

© 1999 FUJITSU LIMITED F16013S-3C-5

Dimensions in mm (inches)

(Continued)

MB3778

(Continued)

16-pin, Plastic SOP
(FPT-16P-M06)

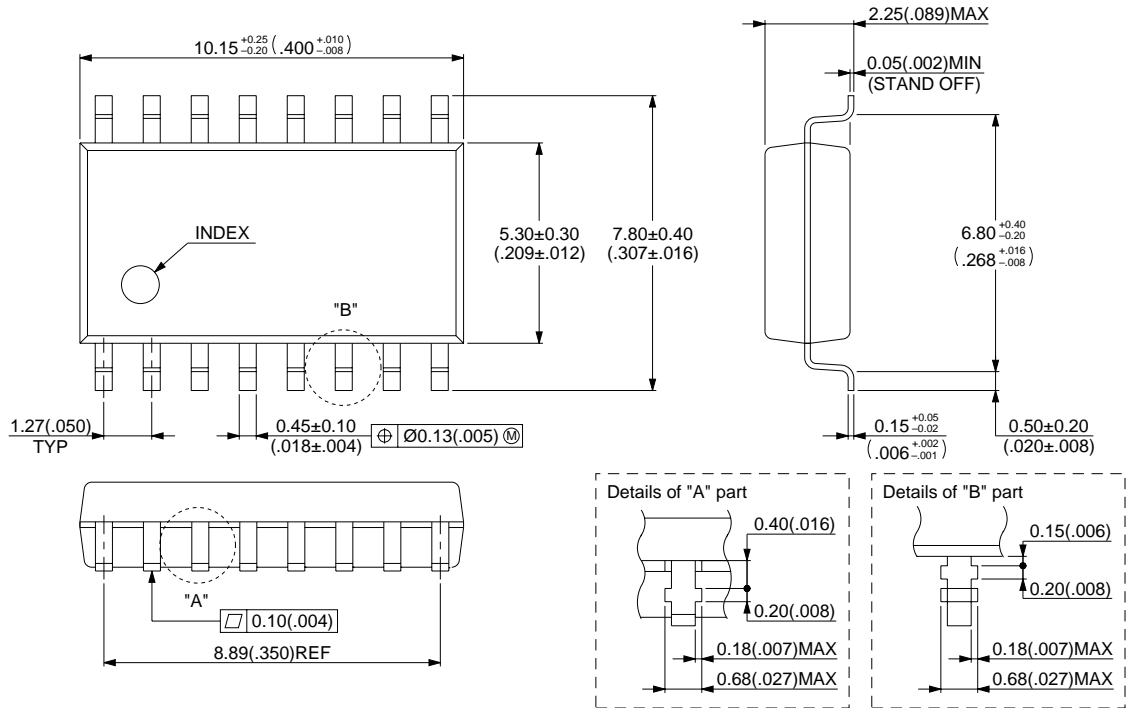

© 1994 FUJITSU LIMITED F16015S-2C-4

Dimensions in mm (inches)

FUJITSU LIMITED

All Rights Reserved.

The contents of this document are subject to change without notice. Customers are advised to consult with FUJITSU sales representatives before ordering.

The information and circuit diagrams in this document are presented as examples of semiconductor device applications, and are not intended to be incorporated in devices for actual use. Also, FUJITSU is unable to assume responsibility for infringement of any patent rights or other rights of third parties arising from the use of this information or circuit diagrams.

The products described in this document are designed, developed and manufactured as contemplated for general use, including without limitation, ordinary industrial use, general office use, personal use, and household use, but are not designed, developed and manufactured as contemplated (1) for use accompanying fatal risks or dangers that, unless extremely high safety is secured, could have a serious effect to the public, and could lead directly to death, personal injury, severe physical damage or other loss (i.e., nuclear reaction control in nuclear facility, aircraft flight control, air traffic control, mass transport control, medical life support system, missile launch control in weapon system), or (2) for use requiring extremely high reliability (i.e., submersible repeater and artificial satellite).

Please note that Fujitsu will not be liable against you and/or any third party for any claims or damages arising in connection with above-mentioned uses of the products.

Any semiconductor devices have an inherent chance of failure. You must protect against injury, damage or loss from such failures by incorporating safety design measures into your facility and equipment such as redundancy, fire protection, and prevention of over-current levels and other abnormal operating conditions.

If any products described in this document represent goods or technologies subject to certain restrictions on export under the Foreign Exchange and Foreign Trade Law of Japan, the prior authorization by Japanese government will be required for export of those products from Japan.

F0012
© FUJITSU LIMITED Printed in Japan